



(12) **EUROPEAN PATENT APPLICATION**

(43) Date of publication:
02.04.2008 Bulletin 2008/14

(51) Int Cl.:
F23G 5/027^(2006.01) F23G 7/00^(2006.01)

(21) Application number: **07116524.5**

(22) Date of filing: **15.09.2007**

(84) Designated Contracting States:
AT BE BG CH CY CZ DE DK EE ES FI FR GB GR HU IE IS IT LI LT LU LV MC MT NL PL PT RO SE SI SK TR
 Designated Extension States:
AL BA HR MK YU

(72) Inventors:
 • **Wysocki, Michal**
31-216, Krakow (PL)
 • **Wysocki, Zygmunt**
31-228, Krakow (PL)

(30) Priority: **20.09.2006 PL 38064406**

(74) Representative: **Hudy, Ludwik**
Kancelaria Patentowa Patelha
Czernichow 4
32-070 Czernichow, Krakow (PL)

(71) Applicant: **Wysocki, Michal**
31-216 Krakow (PL)

(54) **Device and method for removing and utilization of paint coating material and/or waste painting material**

(57) A device for removing and utilization of paint coating material and/or waste painting material and/or lacquer is provided with a chamber (30) with a system of carrying away products of utilization and adapted for placing inside lacquer and/or paint wastes and/or elements to be cleaned and covered by paint and/or lacquer deposits or layers. The chamber made as a reaction chamber (30) has at least one heating part (32) equipped with a heating arrangement (50) and at least one reaction part (31) having space adapted for placing inside lacquer and/or paint wastes and/or elements to be cleaned and

covered by paint and/or lacquer deposits or layers. The process of desiccation, gasifying or de-gasification of the lacquer deposits or wastes is run in the reaction part (31), which is connected through after-reaction gas collectors to installation for purifying and carrying away products of desiccation, de-gasification and gasifying of paint coating material and/or waste painting material to atmosphere. The heating part (32) and the reaction part (31) are separated by a fire-resisting barrier (38) provided with a set of openings (47) joining the heating part (32) and the reaction part (31).

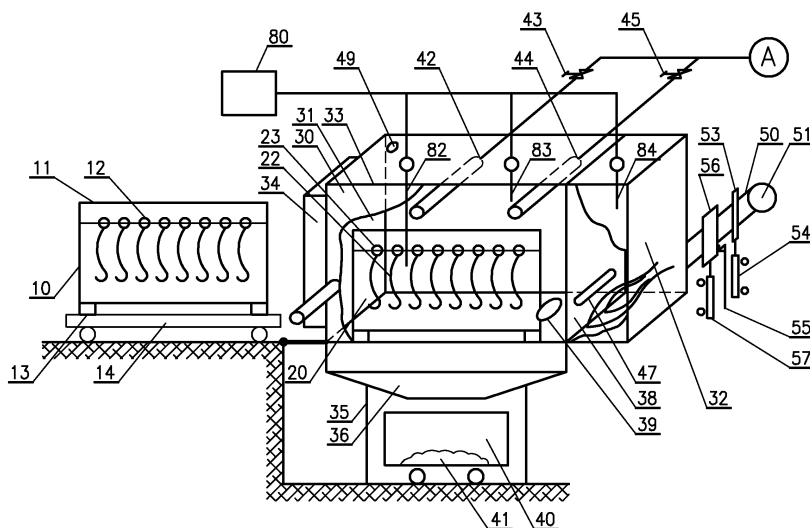

Fig. 1A

Description

[0001] Technical concept presented herein relates to utilization of waste painting material, and more particularly, to a device for removing and utilization of paint coating material and/or waste painting material and a method for removing and utilization of paint coating material and/or waste painting material, especially deposited on elements of equipment of lacquer or paint shops.

[0002] Due to the quick development of the car industry in Poland, yet to recent an imperceptible problem of utilization of paint coating material and waste painting material requires at present the as quickest solution. The problem creates removing the layers of the painting material, which has been deposited during lacquering or painting on elements of equipment of lacquer shops, especially on parts of lacquering chambers and their equipment, namely grates, hangers and stands, on which painted or lacquered objects are placed. Mechanical removing of such layers is time-consuming and labor-consuming, as far as this process is possible to the execution at all. Use of the stream of the liquid under the high pressure for removing lacquer deposits leads to the rise of the huge quantities of the suspensions which utilization is very expensive in the turn. Similarly, removing paint and lacquer deposits by using chemical preparations is expensive and labor-consuming, and so as in the case of removing the paint and lacquer deposits by using the stream of the liquid under the high pressure, leads to the formation of the suspensions which have to be utilized. In turn, at removing the paint and lacquer deposits, by their burning, chemical compounds are formed, which because of the protection of the natural environment, can not be deflated to the atmosphere and requires further processing, enough they did not make up the ecological threat.

[0003] One of above described ways of removing the coatings and the paint and lacquer deposits is known from the patent description PL 164272, in which became to controlled burning the coatings and the paint and lacquer deposits in a device, which is also known from this description. The device mentioned earlier possesses a pyrolytic bathtub with a rotatory cover and a reservoir of sand, which is provided with a funnel finished with a shoot gutter whose end is disposed above the mentioned pyrolytic bathtub, in which elements covered by lacquer or paint deposits are placed. Moreover, the device for controlled burning the lacquer or paint deposits or wastes possesses heating elements for warming the sand, in which the elements are placed, from which the lacquer or paint deposits are removed. The removing the lacquer or paint deposits in the described device begins at placing the palettes including elements with the lacquer or paint deposits in the pyrolytic bathtubs which are filed with dry sand. The sand as well as the air is heated up by means of heating elements. Simultaneously, a winding ventilator calls out the movement of warmed fumes and air, which in turn warm the lacquer or paint deposits to the temper-

ature of the ignition of removed paint and lacquer wastes. Then, the heating elements have been switched off, and the burning process of paint and lacquer wastes and/or deposits is continued self-actively. The fumes derived from the paint and lacquer wastes and/or deposits are driven to the catalytic after-burner, and then directed to the atmosphere.

[0004] The well-known systems have such drawback that they are inconvenient in the use, and need large quantities of energy to carry out the process of removing and utilization of lacquer and/or paint layers deposited on elements of equipment of lacquer shops that makes this process very expensive.

[0005] The idea of the invention is a device for removing and utilization of paint coating material and/or waste painting material and/or lacquer comprising a chamber with a system of carrying away products of utilization and adapted for placing inside lacquer and/or paint wastes and/or elements to be cleaned and covered by paint and/or lacquer deposits or layers. The chamber of this device is a reaction chamber having at least one heating part equipped with a heating arrangement and at least one reaction part having space adapted for placing inside lacquer and/or paint wastes and/or elements to be cleaned and covered by paint and/or lacquer deposits or layers and for running process of desiccation, gasifying or de-gasification of the lacquer deposits or wastes. The reaction chamber is connected through after-reaction gas collectors to installation for purifying and carrying away products of desiccation, de-gasification and gasifying of paint coating material and/or waste painting material to atmosphere and which comprises at least one high-temperature filter, at least one catalytic reactor and at least one additional unit for purifying the gas products formed during desiccation, de-gasification and gasifying of paint coating material and/or waste painting material. The heating part and the reaction part of the reaction chamber are separated by a fire-resisting barrier provided with a set of openings joining the heating part and the reaction part.

[0006] Preferably, the heating arrangement is situated above the set of openings connecting the heating part of the reaction chamber and reaction part of the reaction chamber.

[0007] It is favorable that inlets to the collector of after-reaction gases are placed in walls of the heating part, which are situated at an angle in respect to blow-in direction of hot gases produced by the heating arrangement.

[0008] Preferably, the catalytic reactor is arranged in layers and has, starting from its inlet, an oxidising platinum (Pt) catalyst with admixtures, a palladium catalyst with admixtures and a reducing oxidising catalyst with admixtures.

[0009] It is also favorable that following an outlet of the additional unit for purifying the gas products formed during desiccation, de-gasification and gasifying is disposed an arrangement of ventilators and pumps creating pres-

sure below atmospheric in the reaction chamber as well as draughts and transmission lines for carrying away the gas products of removing and utilization of the paint coating material and/or waste painting material and/or lacquer.

[0010] Preferably, the additional unit for purifying the gas products formed during desiccation, de-gasification and gasifying is a catalytic after-burner to an outlet of which is connected a transmission line for delivering a counterflow air causing a counterflow of air and gases in the opposite direction as compared to the flow direction of the cleaned gas products wherein to an inlet of the catalytic after-burner is connected a return transmission line connecting the inlet of the catalytic after-burner and an inlet of the catalytic reactor, and through which is delivered a counterflow air to the inlet of the catalytic reactor.

[0011] Moreover, the additional system for purifying the gas products formed during desiccation, de-gasification and gasifying can be a carbon adsorber or an adsorber with isosorbide dinitrate, or an adsorber with zeolite inserts or an adsorber with kieselguhr inserts or another adsorber with similar properties and parameters

[0012] It is advantageous that a heat exchanger of the heat exchanger system provided with a pump for forcing to flow a cooling medium is placed in a flow way of gas products formed during desiccation, de-gasification and gasifying of paint coating material and/or waste painting material.

[0013] Preferably, following the outlet of the set of high-temperature filters is disposed a catalytic reactor adapted to reduce the compounds of nitrogen to molecular nitrogen N_2 .

[0014] The present invention solves the problem of removing and utilization of the lacquer and paint layer disposed on the elements of equipment of lacquer shops by a method for removing and utilization of paint coating material and/or waste painting material and/or lacquer by heating the paint coating material and/or the waste painting material and/or the lacquer, and carrying away products of desiccation, de-gasification and gasifying of paint coating material and/or waste painting material, in which the paint coating material and/or the waste painting material and/or the lacquer is placed in a reaction part of a reaction chamber provided with a system for purifying and carrying away gas products of desiccation, de-gasification and gasifying of paint coating material and/or waste painting material. Then, the paint coating material and/or the waste painting material and/or the lacquer is heated by warmth produced in the heating part by means of the heating arrangement and delivered through a set of openings disposed in a fire-resisting barrier separating the reaction part of the reaction chamber and the heating part of the reaction chamber. Moreover, the gas products of desiccation, de-gasification and gasifying before their emitting to the atmosphere are driven to flow by creating pressure below atmospheric at least in the reaction part of the reaction chamber and passed through at least one set of high-temperature filters and at least one catalytic

reactor and at least one additional unit for purifying the gas products formed during desiccation, de-gasification and gasifying of paint coating material and/or waste painting material or lacquer.

5 **[0015]** The invention will now be described by way of an example and with reference to the accompanying drawings in which:

10 Figs. 1A and 1B show a block diagram of a system for removing and utilization of paint coating material and/or waste painting material; and
Fig. 2 shows an additional arrangement for after-purifying outlet gasses.

15 **[0016]** The main unit of the system for removing and utilization of paint coating material and/or waste painting material, shown in Figs. 1A and 1B, is a reaction chamber 30, which serves for complete de-gasification and gasifying of paint coating material and/or waste painting material, advantageously at temperatures about or below
20 500°C. The reaction chamber consists of a reaction part 31 closed by a bolt door or a door 34, and a heating part 32 equipped with a heating arrangement 50, for example a burner. The reaction part 31 and the heating part 32
25 are separated by a fire-resisting barrier 38 provided with a set of openings 47. Dimensions of the reaction part 31 of the reaction chamber 30 depend on dimensions of paint coating material and/or waste painting material and/or dimensions of the elements which are covered by
30 the paint and/or lacquer settlings and/or layers which have to be removed and which have been settled on the elements during their varnishing, for example by painting car parts. In the walls of the reaction chamber 30, especially in the reaction part 31, there are a system of inlets
35 42, 44 of collectors through which gases are driven to transmission lines consisting of a system of pipes, ducts, various kinds of valves 43, 45. The inlets 42, 44 of collectors for carrying after-reaction gases are placed in walls of the heating part, which are situated at an angle
40 in respect to blow-in direction of hot gases produced by the heating arrangement 50. The reaction chamber is equipped with various kind of stands 10, 20, systems of suspensions 11, 12, 23, supports 13, palettes and trolleys 14, as well as sets of vibrators 39 and devices 49 for
45 protecting against the uncontrolled ignitions of the mixture of gases and explosions. Moreover, the system is provided with a shoot basket 36 disposed on brackets 35 and/or a transporter 40, which is placed under the reaction chamber 30, in which are stored remainders 41
50 of the gasified material.

[0017] The heating arrangement 50, used for warming or heating the space of the reaction part 31 possesses a blowing arrangement 51 with a frequency converter serving to change rotary speed of a blowing ventilator of
55 the burner, as well as a set of gate valves 53 with a controller 54 of a gate valve position and an arrangement 56 of dosage of air and/or oxygen with an air gate valve with a drive 57, and a gas dosage 55 of inflammable or flam-

mable gas, air and/or oxygen that are brought to the heating part 32 depending on kind and composition of the layers of the paint or lacquer, which have to be removed. The main task of the arrangement 56 of dosage of air and/or oxygen is controlling the content of oxygen in the reaction chamber 30. The heating arrangement 50 is usually situated above the set of openings 47 of the fire-resisting barrier 38, what prevents penetrating the flame into the reaction part 31 of the reaction chamber 30. The frequency converter serving to change rotary speed of the blowing ventilator of the burner can be made as a separate arrangement or as a part of a control arrangement 80.

[0018] From valves 43, 45, hot gases are forced to flow by a system of fans and compressors through transmission lines consisting of a system of pipes, various kinds of valves and ducts that join to the catalytic reactor 120 through a filter set or an arrangement of high-temperature filters 110 with little eyes of various size or gradation or a set filled with pellets, which collects or accumulates soot and other impurities. The high-temperature filters 110 consists usually of a pre-cleaning filter 111 with large eyes, a middle-sized eye filter 113 and a fine filter 112 for exact purifying the fumes from the dust and small dirt that have not been caught by the pre-cleaning filter and the middle filter. The catalytic reactor 120 has the stratified building in this solution and is equipped in a dosing arrangement 70 and/or an air supplying valve 71 or a dosage arrangement 121 of air or oxygen.

[0019] The catalytic reactor 120 has, starting from its inlet, an oxidising platinum (Pt) catalyst 122 with admixtures, a palladium (Pd) catalyst 124 with admixtures and a reducing oxidising catalyst 126 with admixtures. The catalysts 122, 124, 126 are arranged in layers spread across the whole interior section of the catalytic reactor. Adjacent to the inlet and the outlet of the catalytic reactor 120 are placed shutters with apertures that allow an even flow of oxidation products within the space of the catalytic reactor.

[0020] In the transmission line, which connects the catalytic reactor 120 and a chimney 170, are disposed an arrangement of fans, ventilators and pumps 145 that create the pressure below atmospheric in the reaction chamber 30, draughts and transmission lines as well as in the high-temperature filter 110 and the catalytic reactor 120. The arrangement of ventilators and pumps 145 is controlled by the converter 61 to which a value of the pressure below atmospheric is passed from a sensor for measuring the pressure below atmospheric, temperature and composition of purified gas mixture. At the inlet of the transmission line to the chimney 170 there is disposed a gas analyzer 160 for measuring amounts of harmful and/or hazardous gasses or substances emitted to the atmosphere. Optionally, the elements or units of the system are a catalytic reactor 90 with a reaction insert and a unit 92 for supplying the reduction compounds, a heat exchanger 131 of the heat exchanger system 130 placed in a flow way of gas products as well as a pump 133 for

forcing to flow a cooling medium 132 and an additional unit 140 for purifying the gas products or the after-reaction gases, which can be provided with a set of filters 141. The additional system 140 can be carbon adsorber with isosorbide dinitrate, with zeolite inserts, with kieselguhr inserts or another adsorber with similar properties and parameters or a catalytic after-burner 150. Moreover, the additional system can be provided with, for example, a transmission line running parallel from a valve 182, which is a part of a three-way valve 180, through a fan or an air pump 191, a heat exchanger with a heater 193, and then, through a transmission line 162 and a valve 152 placed in a transmission line connected to an outlet, for example, of the catalytic after-burner 150, and next, to a valve 151 and a transmission line 159 connecting an inlet of the catalytic after-burner 150 with an inlet of the catalytic reactor 120.

[0021] The cleaning process of the elements 22, from which the lacquer waste or deposits or layers have to be removed, for example from nortal and stands 20, begins from their location on stands 20 equipped with the system of suspensions 23 and placing so prepared set of elements 22 and stands 20 into the reaction chamber 30 using the palettes or trolleys 14. In the same time another stand 10 with a frame 11 and supports 13 on which elements 22 have to be placed, can be prepared to be placed into the reaction chamber 30. The stand 20 can possess its own arrangement of vibrators 39, which helps the lacquer residues to fall down from cleaned elements, for example from the nortal and stands. The arrangement of vibrators 39 can also belong to the equipment of the reaction chamber 30. Before the process of removing the paint and lacquer layers and waste starts, the shoot basket 36 is disposed on the brackets 35 and/or on the transporter 40, in which are stored residues or remainders 41 of the gasified material.

[0022] Once the reactor chamber 30 is closed, the heating arrangement 50 used for heating the space of the reaction part 31 of the reaction chamber 30 is turn on and the temperature inside the reaction part 31 is changed according to the programme of predefined change of temperature versus time by means of the blowing or sucking arrangement 51 controlled by the converter of the frequency and by the gate valves 53 with the controller 54 for setting position of the gate valves 53 as well as by means of dosing arrangement 56 with a controller 57 and the supplying arrangement of inactive or flammable gases that are brought to the heating part 32 of the reactor chamber 30 depending on the kind and the composition of the waste and lacquer or paint layers that have to be removed. Flammable gas and volatile fractions, including C_xH_y , CO and other flammable gasses produced during desiccation, gasifying or de-gasification of the lacquer deposits or waste, which takes place at a temperature below 500°C, are forced to flow to the upper part of the reactor chamber 30. When the lacquer waste or layers are heated, flameless oxidation may occur and the products of flameless oxidation are sucked through

the system of inlets 42, 44 of collectors of sucking draught connected to the removal transmission lines and/or draughts which consist of pipes, aerial ducts and air-control valves 43, 45.

[0023] The gas products 46 of desiccation, de-gasification and gasifying of paint coating material and/or waste painting material are directed to the catalytic reactor 120, then through the set of high-temperature filters 110 with little eyes of various size or gradation or a set filled with pellets filling the set of high-temperature filters 110, which consists a pre-cleaning filter 111 with large eyes, a middle-sized eye filter 113 and a fine filter 112 for exact purifying the fumes from the dust and small dirt that have not been caught by the pre-cleaning filter and the middle-sized eye filter. In the catalytic reactor 120 takes place further oxygenation of gas products and small particles to H₂O and CO₂. The temperature of the oxygenation is controlled by supplying predefined quantity of the air and/or the gas which reacts with arising gases or which is indifferent at the suitably low temperature, for example the dioxide of the carbon. The quantity of the air, which is necessary to the flameless oxygenation is regulated by means of the dosing arrangement 70 and/or the air-feeding valve 71 or by means of the arrangement 121 for the dosing the air or oxygen.

[0024] In a case, when the system for removing and utilization of lacquers wastes has to be used for utilization of lacquers wastes, during which the nitrogen compounds are produced, especially the nitrogen oxides NO_x, then the system is equipped with a catalytic reactor adapted to reduce the compounds of nitrogen to molecular nitrogen N₂. Such catalytic reactor can be a unit of another catalytic reactor or make up a separate catalytic reactor 90 with a suitable insert 91 and an arrangement 92 supplying compounds for the reduction of the NO_x, for example the ammonia NH₃, which allows the reduction of the nitrogen oxides NO_x to nitrogen molecular N₂ and water H₂O.

[0025] The hot gasses produced in the catalytic reactor 120 are forced to flow by a system of fans and compressors 145 as a stream of thermal energy. The thermal energy from the oxidation process that is surplus to the requirements of the desiccation, degassing and flameless oxidation of the polluted gasses is passed to an exchanger 131 forming a part of heat-exchange system 130, in which flow of a cooling medium 132 is caused by a pump 133. The cooled gasses are transmitted to the atmosphere through the by-pass flow line or via the heat-exchange system 130 to an additional purifying system, which is mounted optionally. A long-lasting flow of polluted gasses through the additional arrangement 140 for purifying of gasses or any other catalytic after-burner in one direction only would decrease the throughput or the purifying efficiency of the additional arrangement 140 for purifying of gasses or any other active filter. In order to prevent it, once in given period of time and depending on the pollution grade of the gasses, heated air should be transmitted through the additional arrangement 140

for purifying of gasses or active filter in the opposite direction, i.e. from the outlet of the additional arrangement 140 for purifying of gasses or the filter to the inlet of the additional arrangement 140 for purifying of gasses or filter to force the counterflow of air.

[0026] The counterflow of air should be forced if the gasses escaping the catalytic reactor contain impurities in amounts below the admissible levels. If so, the gasses are directed through the by-pass flow line from the valve 182 to a by-pass flow line connected with the chimney 170. The counterflow of air is forced by a pump or blower 191. Upon leaving the blower or the air pump 191, the air is heated in the heater 190 fitted with a radiator 193 to a temperature over 100°C and transmitted through the transmission line 162 and the valve 152 to the catalytic after burner 150, which replaces the additional arrangement 140 for purifying of gasses. Then it is directed to the inlet of the catalytic reactor 120 through the valve 151 and the transmission line 159. Switching from adsorption to desorption cycle and back is achieved through a change of direction in the flow of gasses and air in the catalytic after-burner by means of the valves 151, 152, 153 and 181, 182, 183 and the flow changes in dependence of needs of the catalytic process, which is controlled and adjusted by the help of the control arrangement 80, to which are connected measuring elements 45, 82, 83, 84, 115, 123, 134, 142 for measuring temperature, pressure and composition of the gasses. Moreover, the amount of harmful substances released to the atmosphere, and so the purifying quality of the utilization process, is monitored by a gas-analyser 160 for measuring the content of gasses emitted to the atmosphere.

[0027] The presented preferred embodiments are exemplary only, and are not exhaustive of the scope of the technical concept presented herein. Accordingly, the scope of protection is not limited to the preferred embodiments described in the specification.

40 Claims

1. A device for removing and utilization of paint coating material and/or waste painting material and/or lacquer comprising a chamber (30) with a system for carrying away products of utilization and adapted for placing inside lacquer and/or paint wastes and/or elements to be cleaned and covered by paint and/or lacquer deposits or layers **characterized in that** the chamber is a reaction chamber (30) having at least one heating part (32) equipped with a heating arrangement (50) and at least one reaction part (31) having space adapted for placing inside lacquer and/or paint wastes and/or elements to be cleaned and covered by paint and/or lacquer deposits or layers and for running process of desiccation, gasifying or de-gasification of the lacquer deposits or wastes, and which is connected through after-reaction gas collectors to installation for purifying and carrying

- away products of desiccation, de-gasification and gasifying of paint coating material and/or waste painting material to atmosphere, and comprising at least one high-temperature filter (110), at least one catalytic reactor (120) and at least one additional unit (140) for purifying the gas products formed during desiccation, de-gasification and gasifying of paint coating material and/or waste painting material, wherein the heating part (32) and the reaction part (31) are separated by a fire-resisting barrier (38) provided with a set of openings (47) joining the heating part (32) of the reaction chamber (30) and the reaction part (31) of the reaction chamber (30).
2. The device for removing and utilization of paint coating material and/or waste painting material and/or lacquer according to claim 1, **characterized in that** the heating arrangement (50) is situated above the set of openings (47) connecting the heating part (32) of the reaction chamber (30) and reaction part (31) of the reaction chamber (30).
 3. The device for removing and utilization of paint coating material and/or waste painting material and/or lacquer according to claim 1, **characterized in that** inlets (42, 44) to the after-reaction gas collectors are placed in walls of the reaction part, which are situated at an angle in respect to blow-in direction of hot gases produced by the heating arrangement (50).
 4. The device for removing and utilization of paint coating material and/or waste painting material and/or lacquer according to claim 1, **characterized in that** catalytic reactor (120) is arranged in layers and has, starting from its inlet, an oxidising platinum (Pt) catalyst (122) with admixtures, a palladium (Pd) catalyst (124) with admixtures and a reducing oxidising catalyst (126) with admixtures.
 5. The device for removing and utilization of paint coating material and/or waste painting material and/or lacquer according to claim 1, **characterized in that** following an outlet of the additional unit (140) for purifying the gas products formed during desiccation, de-gasification and gasifying is disposed an arrangement of ventilators and pumps creating pressure below atmospheric in the reaction chamber (30) and draughts and transmission lines for carrying away the gas products of removing and utilization of the paint coating material and/or waste painting material and/or lacquer.
 6. The device for removing and utilization of paint coating material and/or waste painting material and/or lacquer according to claim 1, **characterized in that** the additional unit for purifying the gas products formed during desiccation, de-gasification and gasifying is a catalytic after-burner (150) to an outlet of which is connected a transmission line (162) for delivering a counterflow air causing a counterflow of air and gases in the opposite direction as compared to the flow direction of the cleaned gas products wherein to an inlet of the catalytic after-burner (150) is connected a return transmission line (159) connecting the inlet of the catalytic after-burner (150) and an inlet of the catalytic reactor (120), and through which is delivered a counterflow air to the inlet of the catalytic reactor (120).
 7. The device for removing and utilization of paint coating material and/or waste painting material and/or lacquer according to claim 1, **characterized in that** the additional system for purifying the gas products formed during desiccation, de-gasification and gasifying is a carbon adsorber or an adsorber with isosorbide dinitrate, or an adsorber with zeolite inserts or an adsorber with kieselguhr inserts or another adsorber with similar properties and parameters
 8. The device for removing and utilization of paint coating material and/or waste painting material and/or lacquer according to claim 1, **characterized in that** a heat exchanger (131) of the heat exchanger system (130) provided with a pump for forcing to flow a cooling medium (132) is placed in a flow way of gas products formed during desiccation, de-gasification and gasifying of paint coating material and/or waste painting material.
 9. The device for removing and utilization of paint coating material and/or waste painting material and/or lacquer according to claim 1, **characterized in that** following the outlet of the set of high-temperature filters (110) is disposed a catalytic reactor adapted to reduce the compounds of nitrogen to molecular nitrogen N₂.
 10. A method for removing and utilization of paint coating material and/or waste painting material and/or lacquer by heating the paint coating material and/or the waste painting material and/or the lacquer, and carrying away products of desiccation, de-gasification and gasifying of paint coating material and/or waste painting material **characterised in that** the paint coating material and/or the waste painting material and/or the lacquer is placed in a reaction part of a reaction chamber connected to a system for purifying and carrying away gas products of desiccation, de-gasification and gasifying of paint coating material and/or waste painting material, wherein the paint coating material and/or the waste painting material and/or the lacquer is heated by warmth produced in the heating part by means of the heating arrangement and delivered through a set of openings disposed in a fire-resisting barrier separating the reaction part of the reaction chamber and the heating

part of the reaction chamber, and wherein the gas products of desiccation, de-gasification and gasifying before their emitting to the atmosphere are driven to flow by creating pressure below atmospheric at least in the reaction part of the reaction chamber and passed through at least one set of high-temperature filters and at least one catalytic reactor and at least one additional unit for purifying the gas products formed during desiccation, de-gasification and gasifying of paint coating material and/or waste painting material or lacquer.

5

10

15

20

25

30

35

40

45

50

55

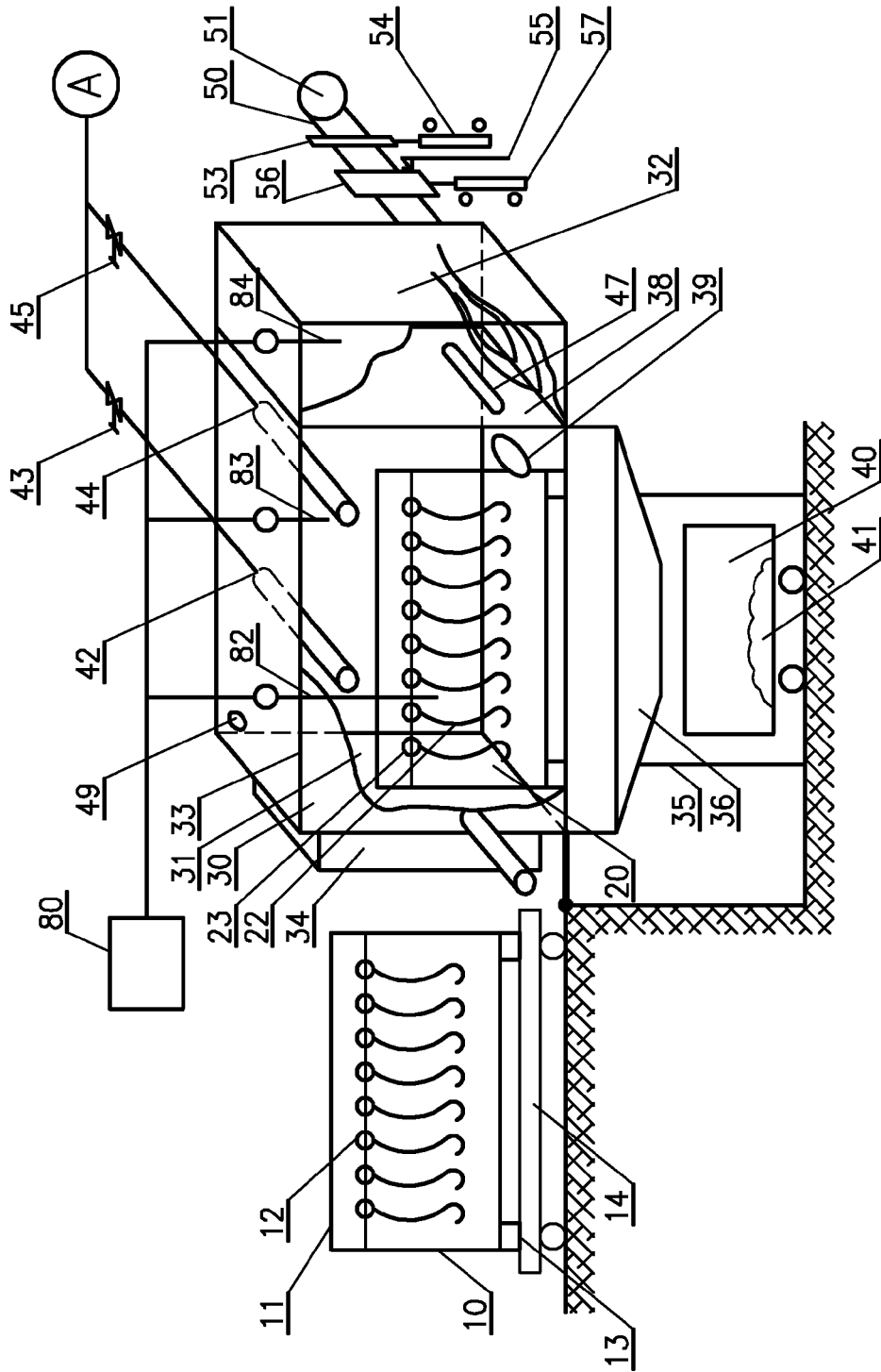

Fig. 1A

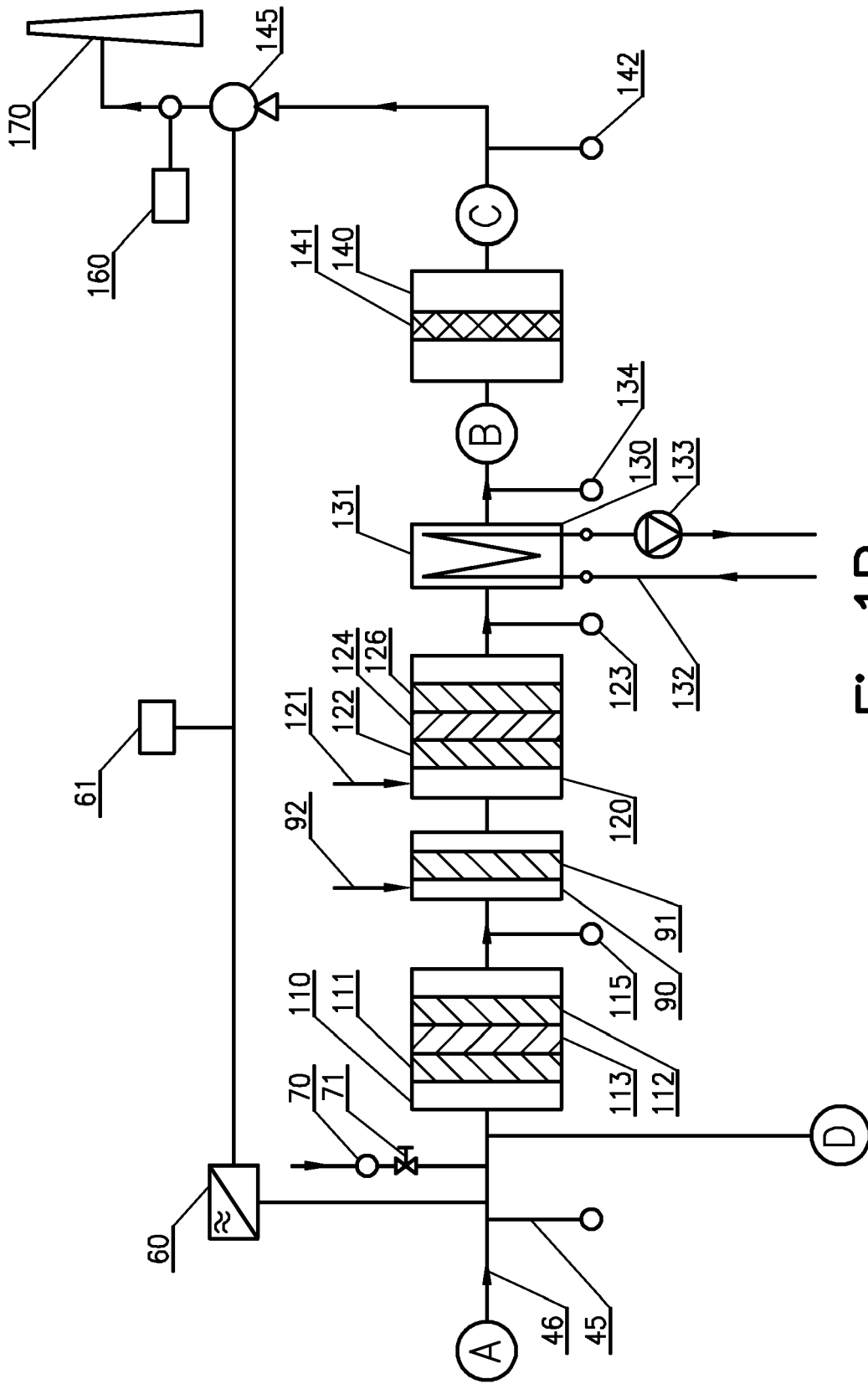

Fig.1B

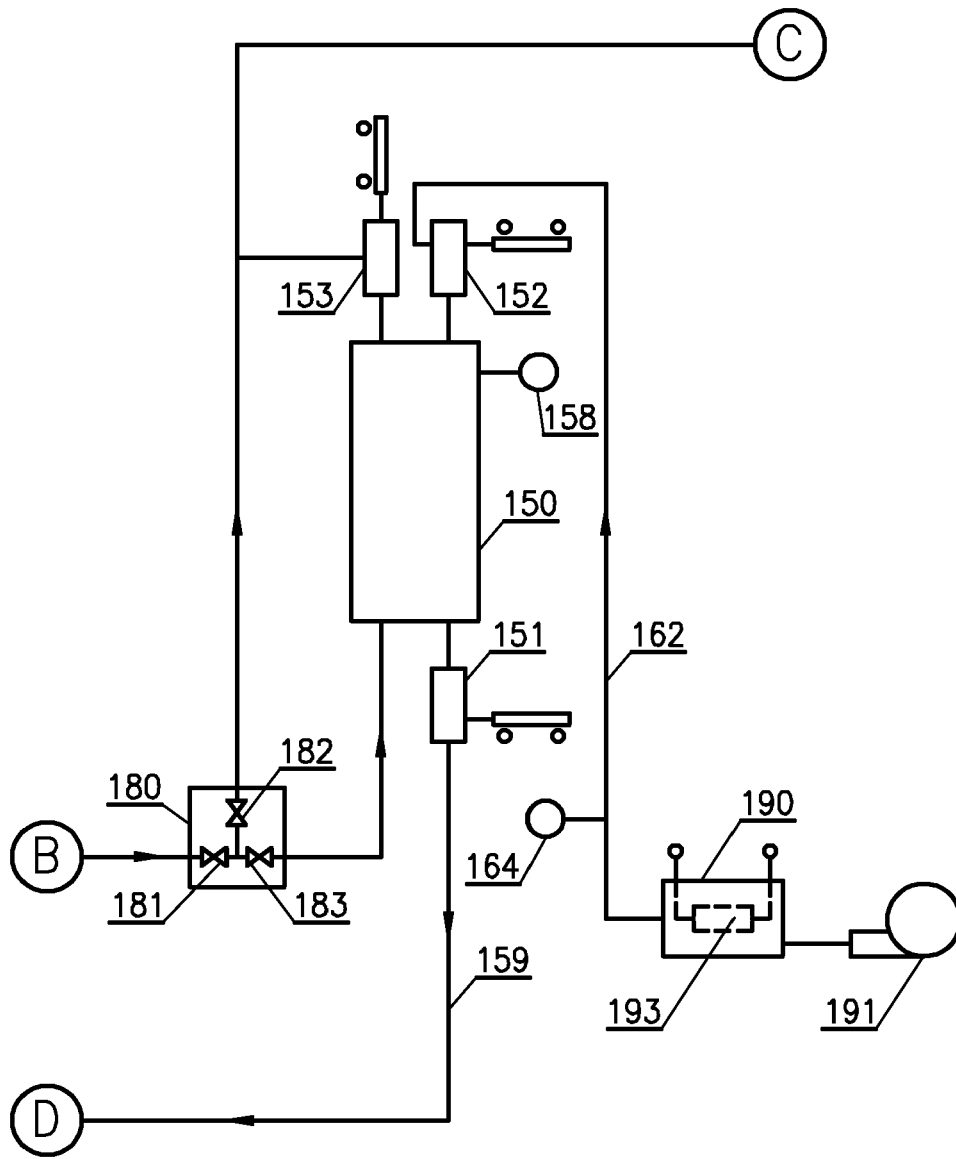

Fig.2

REFERENCES CITED IN THE DESCRIPTION

This list of references cited by the applicant is for the reader's convenience only. It does not form part of the European patent document. Even though great care has been taken in compiling the references, errors or omissions cannot be excluded and the EPO disclaims all liability in this regard.

Patent documents cited in the description

- PL 164272 [0003]