

(19) World Intellectual Property Organization
International Bureau



(43) International Publication Date
25 June 2009 (25.06.2009)

PCT

(10) International Publication Number
WO 2009/078050 A1

- (51) International Patent Classification:
A47L 9/04 (2006.01) A47L 9/30 (2006.01)
- (21) International Application Number:
PCT/IT2008/000741
- (22) International Filing Date:
4 December 2008 (04.12.2008)
- (25) Filing Language: English
- (26) Publication Language: English
- (30) Priority Data:
TV2007A000200
19 December 2007 (19.12.2007) IT

AO, AT, AU, AZ, BA, BB, BG, BH, BR, BW, BY, BZ, CA, CH, CN, CO, CR, CU, CZ, DE, DK, DM, DO, DZ, EC, EE, EG, ES, FI, GB, GD, GE, GH, GM, GT, HN, HR, HU, ID, IL, IN, IS, JP, KE, KG, KM, KN, KP, KR, KZ, LA, LC, LK, LR, LS, LT, LU, LY, MA, MD, ME, MG, MK, MN, MW, MX, MY, MZ, NA, NG, NI, NO, NZ, OM, PG, PH, PL, PT, RO, RS, RU, SC, SD, SE, SG, SK, SL, SM, ST, SV, SY, TJ, TM, TN, TR, TT, TZ, UA, UG, US, UZ, VC, VN, ZA, ZM, ZW.

(84) Designated States (unless otherwise indicated, for every kind of regional protection available): ARIPO (BW, GH, GM, KE, LS, MW, MZ, NA, SD, SL, SZ, TZ, UG, ZM, ZW), Eurasian (AM, AZ, BY, KG, KZ, MD, RU, TJ, TM), European (AT, BE, BG, CH, CY, CZ, DE, DK, EE, ES, FI, FR, GB, GR, HR, HU, IE, IS, IT, LT, LU, LV, MC, MT, NL, NO, PL, PT, RO, SE, SI, SK, TR), OAPI (BF, BJ, CF, CG, CI, CM, GA, GN, GQ, GW, ML, MR, NE, SN, TD, TG).

(71) Applicant (for all designated States except US): EU-ROFLEX SRL [IT/IT]; Via dei Colli 59, I-31058 Susegana (TV) (IT).

Declaration under Rule 4.17:

— of inventorship (Rule 4.17(iv))

(71) Applicant and
(72) Inventor: MILANESE, Pierantonio [IT/IT]; Via Val Longa 18, I-31058 Susegana (TV) (IT).

Published:

— with international search report
— before the expiration of the time limit for amending the claims and to be republished in the event of receipt of amendments

(81) Designated States (unless otherwise indicated, for every kind of national protection available): AE, AG, AL, AM,

(54) Title: VACUUM CLEANER BRUSH WITH SELF-POWERED UVC LAMP

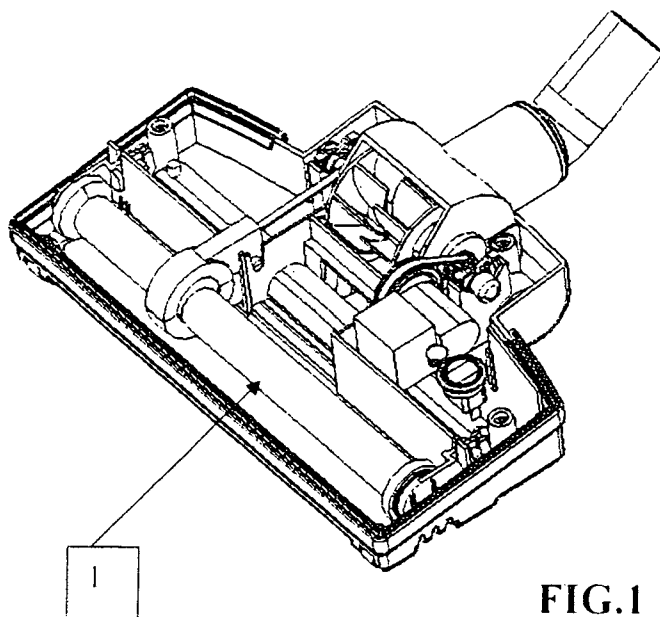

FIG. 1

(57) Abstract: A Nozzle (1) for a vacuum cleaner, with an integrated UVC germicide lamp (3) that works without being connected to an external electric power supply because the current generator (8) necessary for its powering is part of the nozzle itself.

WO 2009/078050 A1

TITLE

VACUUM CLEANER BRUSH WITH SELF-POWERED UVC LAMP

DESCRIPTION

Object of the present patent is a brush for vacuum cleaner with integrated UV-C (germicide) lamp, that can work without being connected to an external electric power supply, because the current generator, necessary for its powering, is part of the product itself.

The present patent is applied to the field of vacuum cleaners and relevant accessories. Due to its construction peculiarities, which will be described afterwards, it can be also applied to steam cleaners and cleaning appliance fields.

Several kinds of brushes are known among vacuum cleaners accessories, used for different purposes: floor and parquet brushes; carpet and sofas brushes; this patent refers to this kind of accessories.

Constructive methods of brushes present in the market, divided into floor and/or parquet brushes, intended to vacuum on hard and regular surfaces, and brushes for soft and irregular surfaces, such as carpets, sofas and fitted carpets.

This last kind of brushes has additionally a roller, with some bristles shrunk-on. This roller, when rotating, moves the dirt which is nested into the fabric, and facilitates its suction through the slit which is under the brush.

The roller can operate through an electric ratio-motor or an air operating motor.

Brushes that are present in the market can suck the dirt from a surface but cannot "disinfect" it. For this reason, in the last years, we have seen new appliances in the market that have this "disinfection" function; this kind of appliances utilize detergents or water steam at high temperature.

Recently new products, named "sweeper", have been put in the market; they combine UVC lamps with rotating carpet brushes (see patent applications JP2005124861 A2 – EP1714601 A2 - WO2006/015390 A2)

The germicide lamps (UVC) give out a light with a wave length of 253,70 nm named "germicide" for its

capability to neutralize bacteria. As a matter of fact the exposure of these bacteria colonies to the ultra violet UVC radiation neutralizes their effect. These new products overcome the limit of normal vacuum cleaners' brushes and thus they "disinfect" as well. These "sweepers" anyway show some limits, first of all the powering of lamps by using rechargeable batteries. This kind of powering presents some inconvenience for the final user who has to remember to charge the battery; electricity consumption due to everlasting charges and not last the chemical limit of rechargeable batteries, in fact, continual charges and discharges damage these batteries that need then to be substituted with all ecological problems linked to their disposal and their high cost. Electrical powering of the lamp can be done also through the electrical power supply of the vacuum cleaner, and this can solve the problems created by batteries. This requires a more complicated construction, in fact the power supply must pass through the flexible suction hoses, and to do this a particular and expensive execution of these hoses is needed: they have to be co-extruded and cables have to pass well separated from the suction channel. In particular, for wet & dry appliances or steam generators, the execution of these brushes needs a high grade of protection from humidity thus requiring considerable and complicated project for its construction.

The aim of this patent is to solve the described problems, i.e. to create a kind of brushes equipped with this "disinfection" system through UVC lamps, combined to a self-powering system with no need of batteries or external electrical power supply.

The product is then universal and suitable for any vacuum cleaner on the market because it does not need any adaptation or interface of the appliance.

This result is entirely and fully performed by the invention which is the object of the present patent, and realized as follows.

The air sucked by the motor fan inside the vacuum cleaner, connected to the brush through the pipe union (4), enters the brush through the suction inlet (5). Through the internal structure of the brush the air is conveyed to the fan (2) that, due to this forced air flow rotates at high speed, and then goes out of the pipe union towards the appliance. Approximate but not mandatory rotation speed of this fan (2) is about 2000-

2500 rounds per minute. The fan (2) is connected, through a timing belt (7), to a synchronous motor or a dynamo (8), that, rotating, creates electric current at a certain voltage. This current is then transformed by an electronic board (6) and thus used to switch on the UVC lamp (3) and keep it lighted. A switch (9) is connected in series between the motor/dynamo (8) and the electronic board (6), that is used to interrupt the load generated by the motor (8) and allow, in particular applications if needed, the connection of the fan (2), through another belt (10), also to a rotating brush (1) for the carpet cleaner function.

CLAIMS

1. Brush for vacuum cleaner with a germicide lamp UVC (3), which is characterized by the fact of being self-powered by a dynamo operated by the sucked air flow.
2. Brush for vacuum cleaner as per claim 1., characterized by the fact that the current generator can be either a dynamo or a synchronous motor.
3. Brush for vacuum cleaner as per claim 1., characterized by the fact that the current generator is used to power a UVC lamp.

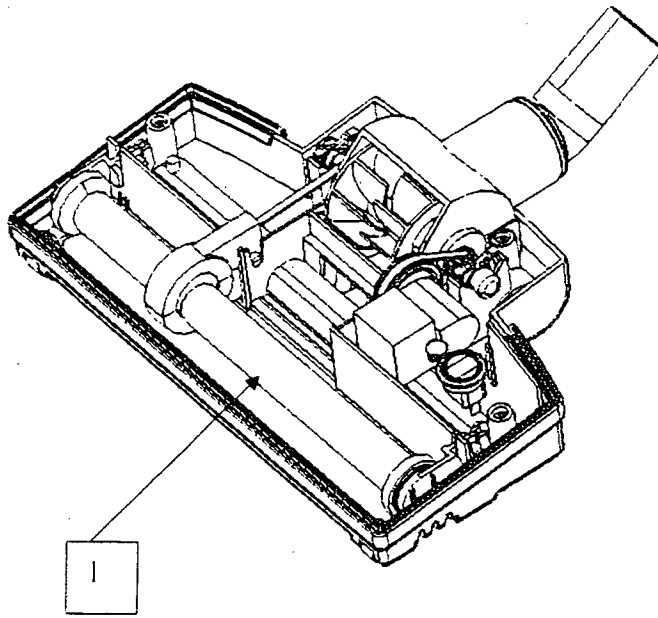

FIG.1

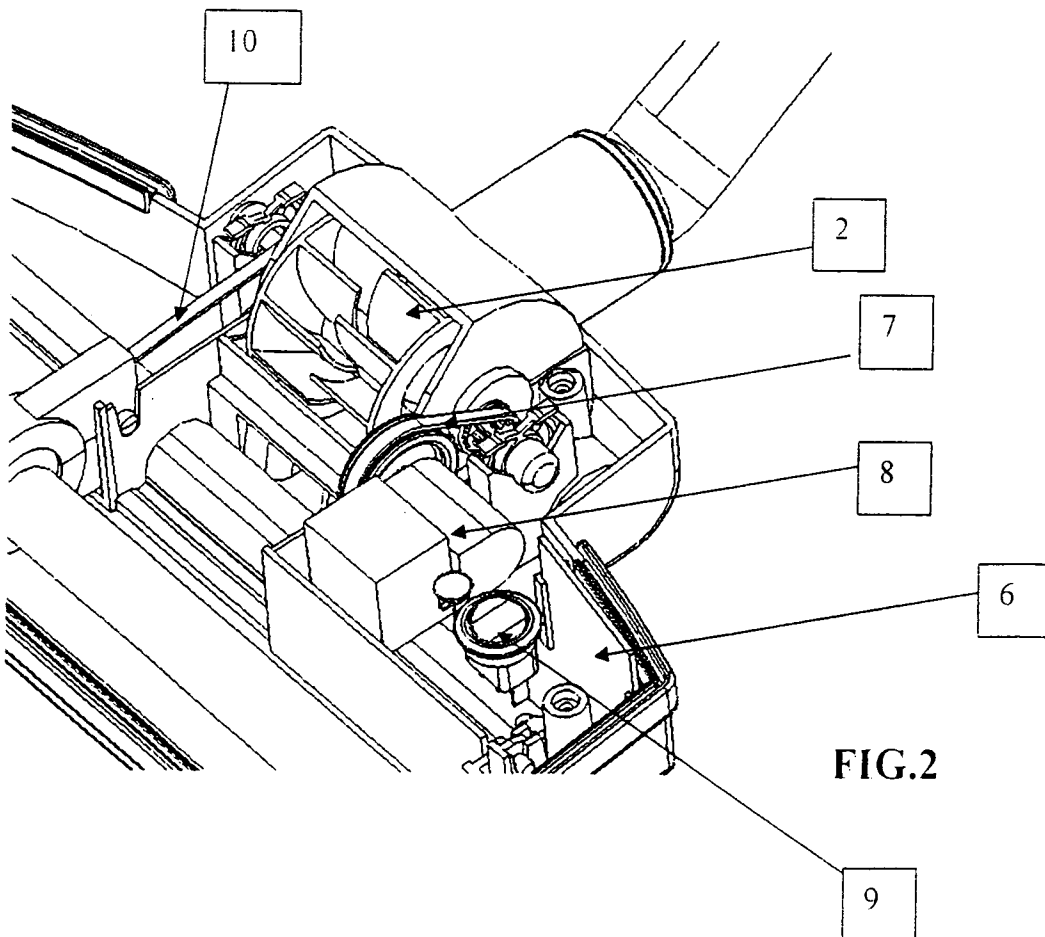

FIG.2

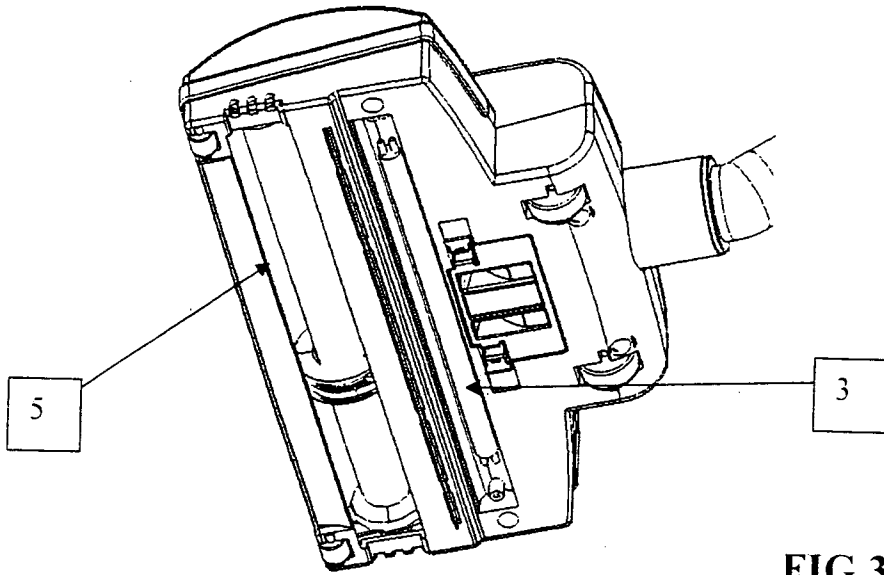

FIG.3

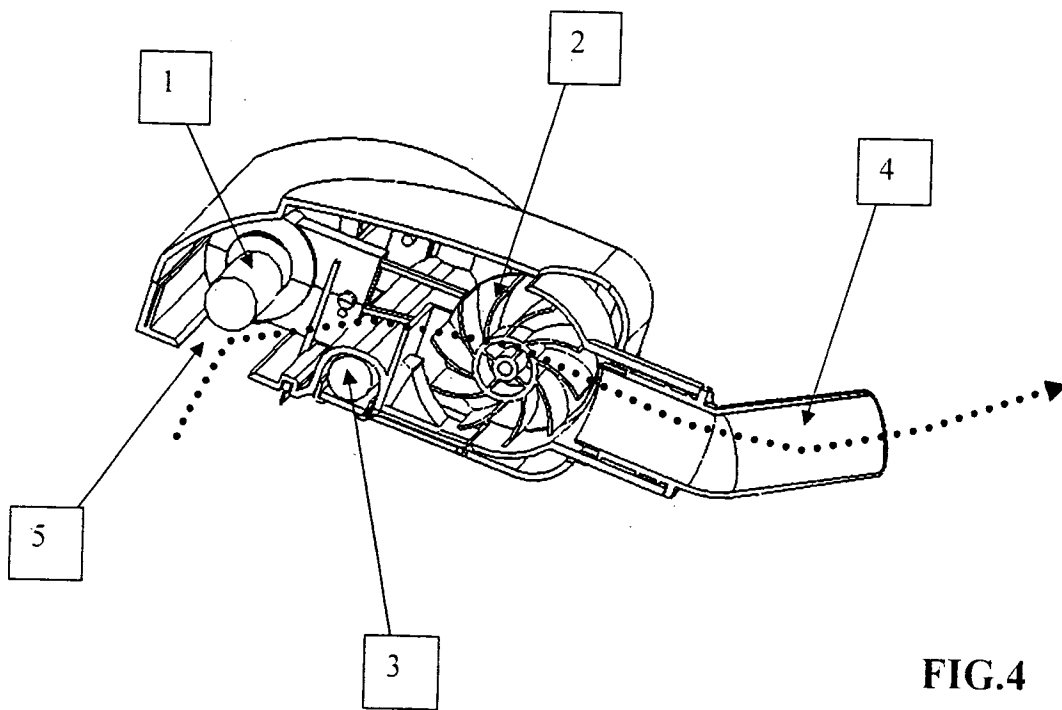

FIG.4

INTERNATIONAL SEARCH REPORT

International application No
PCT/IT2008/000741

A. CLASSIFICATION OF SUBJECT MATTER INV. A47L9/04 A47L9/30				
According to International Patent Classification (IPC) or to both national classification and IPC				
B. FIELDS SEARCHED				
Minimum documentation searched (classification system followed by classification symbols) A47L A61L				
Documentation searched other than minimum documentation to the extent that such documents are included in the fields searched				
Electronic data base consulted during the international search (name of data base and, where practical, search terms used) EPO-Internal				
C. DOCUMENTS CONSIDERED TO BE RELEVANT				
Category*	Citation of document, with indication, where appropriate, of the relevant passages	Relevant to claim No.		
X	US 2006/216193 A1 (JOHNSON KAJ A [US] ET AL) 28 September 2006 (2006-09-28) the whole document	1-3		
X	US 2007/192986 A1 (GARCIA KEN V [US] ET AL) 23 August 2007 (2007-08-23) paragraph [0034] paragraph [0044] - paragraph [0045] paragraph [0050] figures 1,6,7	1,2		
A	EP 1 832 213 A (SAMSUNG KWANGJU ELECTRONICS CO [KR]) 12 September 2007 (2007-09-12) paragraph [0012] paragraph [0037] - paragraph [0038] figures 2,3	1		
<input type="checkbox"/> Further documents are listed in the continuation of Box C. <input checked="" type="checkbox"/> See patent family annex.				
* Special categories of cited documents : <table style="width:100%; border:none;"> <tr> <td style="width:50%; border:none;"> *A* document defining the general state of the art which is not considered to be of particular relevance *E* earlier document but published on or after the international filing date *L* document which may throw doubts on priority claim(s) or which is cited to establish the publication date of another citation or other special reason (as specified) *O* document referring to an oral disclosure, use, exhibition or other means *P* document published prior to the international filing date but later than the priority date claimed </td> <td style="width:50%; border:none;"> *T* later document published after the international filing date or priority date and not in conflict with the application but cited to understand the principle or theory underlying the invention *X* document of particular relevance; the claimed invention cannot be considered novel or cannot be considered to involve an inventive step when the document is taken alone *Y* document of particular relevance; the claimed invention cannot be considered to involve an inventive step when the document is combined with one or more other such documents, such combination being obvious to a person skilled in the art. *Z* document member of the same patent family </td> </tr> </table>			*A* document defining the general state of the art which is not considered to be of particular relevance *E* earlier document but published on or after the international filing date *L* document which may throw doubts on priority claim(s) or which is cited to establish the publication date of another citation or other special reason (as specified) *O* document referring to an oral disclosure, use, exhibition or other means *P* document published prior to the international filing date but later than the priority date claimed	*T* later document published after the international filing date or priority date and not in conflict with the application but cited to understand the principle or theory underlying the invention *X* document of particular relevance; the claimed invention cannot be considered novel or cannot be considered to involve an inventive step when the document is taken alone *Y* document of particular relevance; the claimed invention cannot be considered to involve an inventive step when the document is combined with one or more other such documents, such combination being obvious to a person skilled in the art. *Z* document member of the same patent family
A document defining the general state of the art which is not considered to be of particular relevance *E* earlier document but published on or after the international filing date *L* document which may throw doubts on priority claim(s) or which is cited to establish the publication date of another citation or other special reason (as specified) *O* document referring to an oral disclosure, use, exhibition or other means *P* document published prior to the international filing date but later than the priority date claimed	*T* later document published after the international filing date or priority date and not in conflict with the application but cited to understand the principle or theory underlying the invention *X* document of particular relevance; the claimed invention cannot be considered novel or cannot be considered to involve an inventive step when the document is taken alone *Y* document of particular relevance; the claimed invention cannot be considered to involve an inventive step when the document is combined with one or more other such documents, such combination being obvious to a person skilled in the art. *Z* document member of the same patent family			
Date of the actual completion of the international search 2 April 2009		Date of mailing of the international search report 15/04/2009		
Name and mailing address of the ISA/ European Patent Office, P.B. 5818 Patentlaan 2 NL - 2280 HV Rijswijk Tel. (+31-70) 340-2040, Fax: (+31-70) 340-3016		Authorized officer Baumgärtner, Ruth		

INTERNATIONAL SEARCH REPORT

Information on patent family members

International application No
PCT/IT2008/000741

Patent document cited in search report	Publication date	Patent family member(s)	Publication date
US 2006216193	A1	28-09-2006	NONE
US 2007192986	A1	23-08-2007	US 2009000056 A1 01-01-2009
EP 1832213	A	12-09-2007	RU 2339291 C2 27-11-2008 US 2007204427 A1 06-09-2007