

Jan. 9, 1940.

P. HADAMOVSKY

2,186,169

LOW TEMPERATURE CARBONIZING RETORT

Filed April 10, 1937

2 Sheets-Sheet 1

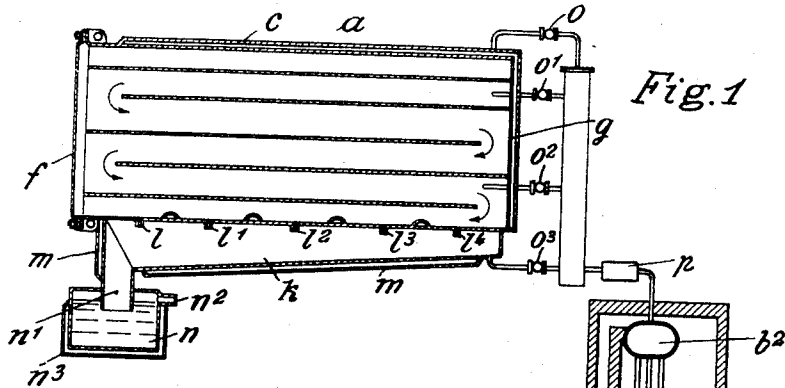

Fig. 1

Fig. 2

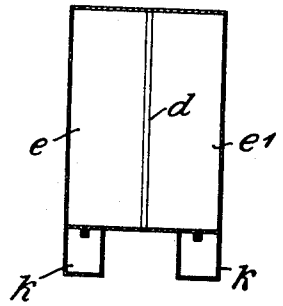

Fig. 3

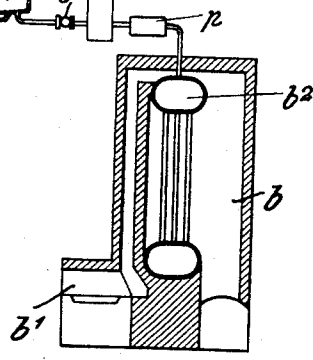

Fig. 5 Fig. 6.

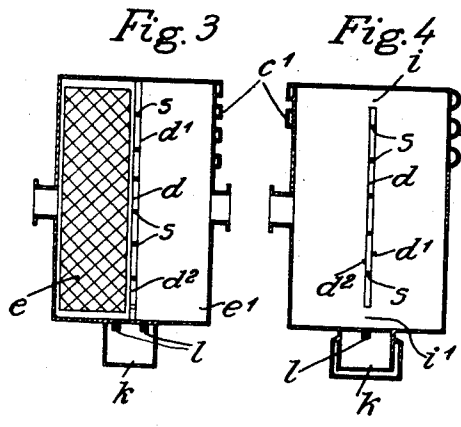
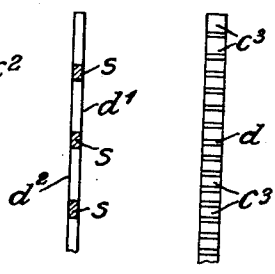

Fig. 4



Inventor:

Paul Hadamovsky,
 By *Alfred...*
 Att.

Jan. 9, 1940.

P. HADAMOVSKY

2,186,169

LOW TEMPERATURE CARBONIZING RETORT

Filed April 10, 1937

2 Sheets-Sheet 2

Fig. 7

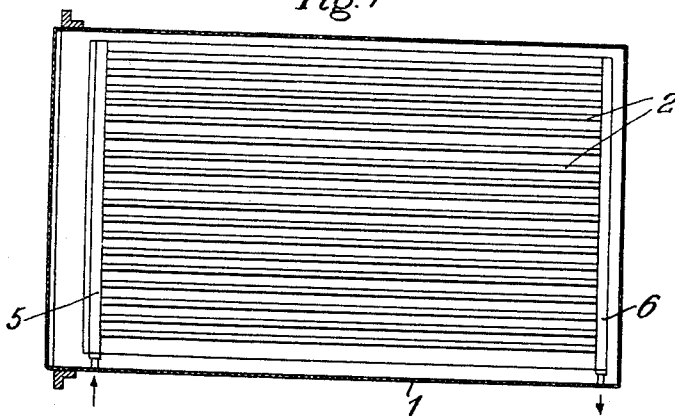

Fig. 8

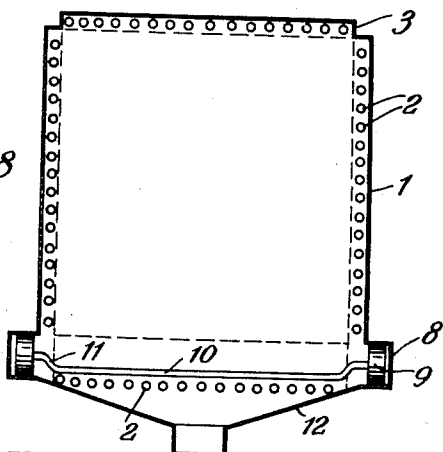

Fig. 9

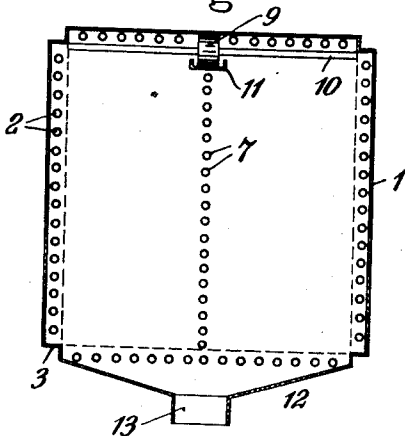
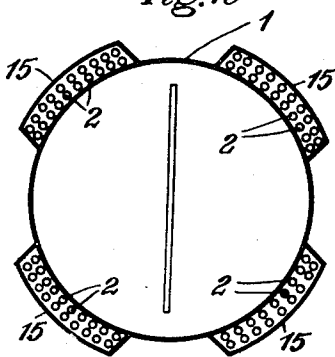

Fig. 10



Inventor:

Paul Hadamovsky,
 By Alfred Klein,
 atty.

UNITED STATES PATENT OFFICE

2,186,169

LOW TEMPERATURE CARBONIZING RETORT

Paul Hadamovsky, Berlin-Wilmersdorf, Germany

Application April 10, 1937, Serial No. 136,109

In Germany April 12, 1935

3 Claims. (Cl. 202—105)

The invention relates to a low temperature carbonizing retort for carbonizing and dry distilling wood and other materials containing cellulose, acetic lime, for carbonizing bones or for similar purposes.

Hitherto, the carbonization or dry distillation of wood and other materials containing cellulose is carried out almost exclusively in retorts of various shapes and dimensions or in apparatus similar to retorts, by means of direct heating with coal, wood or gas. The invention has for its object to eliminate the drawbacks connected with direct heating of retorts of this type and to heat the walls of the retort indirectly by means of a material which transfers the heat from the heat generator to the walls or the shell of the retort. Low temperature carbonizing retorts of this kind have already been suggested, but they were not suited, because of their design and construction, for working with materials, for the treatment of which the novel low temperature carbonizing retort is intended. In particular, the known retorts were not suitable for the treatment of wood, which is worked in large pieces and requires, therefore, large size retort chambers, so that especially in this field retorts of large dimensions have been generally adopted. Where it is intended to heat such retort chambers or batteries directly, great difficulties are experienced in heating the total inside space to the temperatures required for carbonization. In order to obviate these difficulties, I provide the walls with ducts, conduits or tubes for carrying the medium transmitting the heat, in part or entirely adjacent to the interior of the retorts or directly inside of the retorts. As a consequence, the heat radiated from the walls of the conduits or tubes carrying the heat transmitting medium can exercise its effect directly on the material to be treated.

The invention can be practically carried out in a number of different ways. For example, the retort walls may consist of tubes of any cross-section adjacently disposed, or profile elements, for instance of inverted U-shape, may be welded to the retort walls for the purpose of forming the conduits for the heat transmission medium. Also the retort walls may be formed by means of two plates which are connected one to the other by means of suitably arranged traverses, stay bolts or cross-pieces in order to provide conduits or channels for the heat transmission medium.

Another modification of the invention consists in that the channels, ducts or tubes for the heat transmission medium are arranged entirely within the interior space of the retort, close to the

inside of the walls limiting the interior space of the retort. In this case the tubes radiate their heat from their entire surface into the inside of the retort. As far as their heating surface is directed towards the walls of the retort, the heat is radiated back or reflected from these walls, a condition that may be improved by the tubes being spaced apart from each other.

According to a particular feature of the invention, the retort may be provided with one or with a plurality of sectional or partition walls constructed after the completion of the retort walls and being heated. It has been suggested already to provide in low temperature carbonizing plants radiators in the form of cores in the material to be treated; however, the heating of the material to be treated which passes continuously through the retort has been effected only by means of these heating elements placed within the flow of the material. An arrangement of this nature would be insufficient for the purposes of the invention which require the heating of the material from all sides, while the heated sectional walls merely constitute an auxiliary means of assuring an ample and sufficient heating effect in all parts of the interior of the retorts.

The invention will be better understood from the following detailed description with reference to the accompanying drawings wherein by way of example some embodiments of the invention are diagrammatically shown, and wherein

Fig. 1 is a longitudinal section through a complete plant according to the invention;

Figs. 2, 3 and 4 are cross-sections illustrating several modifications of the novel retort;

Figs. 5 and 6 are sectional views illustrating further possibilities of arranging the retort walls;

Fig. 7 is a longitudinal section through another modification, of which Fig. 8 is a cross-section.

Figs. 9 and 10 are cross-sectional views of further embodiments of the invention.

The heat transmitting fluid which may be gaseous or liquid (for example steam, water, oil, salt brine, air, gas or the like) is heated in a tube system b^2 of the heat generator b (Fig. 1) which is provided with a small box or combustion chamber b^1 , the fire gases of which pass along the tube system b^2 . The circulation of the heat transmitting fluid may be effected by thermostatic force or by pumps p , or other suitable means (Fig. 1) and it is regulated by means of check-valves o , o^1 etc. The heat transmitting fluid thus reaches the heating elements provided in the wall of the retort a .

The heating apparatus b , b^1 may take the form

of a heat generating equipment for feeding the required heat to a plurality of retorts.

According to the invention, the channels or tubes for the heat transmitting medium may be arranged so that at least a portion of their walls is situated within the interior of the retorts or is adjacent to the latter. In Figs. 3 and 4, for example, there are welded onto the outer walls of the retort welded half-tube profiles of either angular shape — c^1 (Fig. 3)— or of rounded shape c^2 (Fig. 4). Alternatively, these tubes may be welded to the inside of the retort walls.

In the embodiments shown in Figs. 7 to 10, the outer wall of the retort made for example of sheet metal is denoted by l . It may be suitably heat-insulated on its outside. Along the inside of the wall l are arranged, independent from the wall, heating tubes 2 through which flows the heat transmitting medium. These tubes 2 preferably constitute one tube battery or system each along the upper or top wall, along the side wall and along the bottom. For the purpose of installing such tube batteries it is advisable to provide at the retort wall l receding corners 3 , as shown in Figs. 8 and 9, so that the vertically and horizontally extending tube batteries will accurately fit the presumptive width and height of the useful space of the retort. The tubes 2 , forming one battery and arranged either horizontally or upright, are preferably connected to common feeding and discharge pipes 5 and 6 for the heat transmitting medium. The arrangement is preferably made so that each tube battery may be removed or installed as a mechanical unit without any trouble or difficulty.

A further possibility of installing a maximum of heating tubes without affecting the open width of the retort chamber and thereby obtaining a maximum heating effect, is shown in Fig. 10. In this case a circular cross-section of the retort has been adopted by way of example. This circular cross-section is provided at any number of points with projecting spaces 15 which may receive a suitable number of heating tubes 2 . It is of advantage also in this case to combine all the tubes 2 incorporated into each space 15 into batteries or groups. By a suitable shaping and dimensioning of the projecting spaces 15 , they may receive any number of heating tubes, so that the heating surface may be increased to an almost unlimited extent.

The material to be treated is generally charged into the retorts of this type by means of trucks. Because of the space taken up by the rollers and the underframe of the truck as well as by the necessary guiding means much valuable space is lost in the retorts. Also the distance of the material to be treated from the heating tubes or heating conduits 2 is materially increased. It is an object of this invention to remove also this drawback.

In Fig. 8 this purpose is attained by grooved recesses 8 provided near the bottom in the side walls of retort wall l , in which grooves run the rollers or wheels 9 of the truck. The axle 10 is cranked or offset downward at 11 , so that it moves closely over the lower tube range 2 .

In Fig. 9 the partition 7 has been formed as a support for the guide rail 10 arranged at its upper side. Instead of being carried by the partition 7 , the guide rail may be supported in any other suitable manner. In this arrangement the truck to be charged with the material has been given the form of a suspension truck. Inasmuch as the upper tube range 2 has been inter-

rupted in order to take the roller 9 , the axle 10 is positioned closely below the upper tube range so that also in this case the object of the invention has been realized. If the truck is of the suspension type, the lateral recesses 8 of Fig. 8 may be provided also at the top part of the retort chamber, in which case the rail 11 may serve as an additional middle support of the truck axle.

In order to cause the heat to penetrate more rapidly into the material to be treated, the retort may be divided lengthwise by means of one or a plurality of partitions d which are also heated by means of the heat transmission medium. The partitions d are constructed in the same way as the outer walls of the retort. For instance they may consist of double-shell wrought-iron plates, the inner space of which is sub-divided into a system of conduits of any desired type, or they may consist of tube screens made of round or angular pipes, or they may be provided and arranged in any other way so that the heat transmitting medium may circulate freely in them. It is thus possible to subdivide or split up the "core" of the material to be carbonized. If, for instance, a vertically arranged partition d is used, the heat will radiate not only upon four surfaces, but upon six surfaces of the material to be distilled. It is evident that in this way the distillation or carbonizing process is materially intensified and shortened.

According to the modification shown in Figs. 2 and 3, the heated partition d is rigidly connected to the top and the bottom of the retort, so that two single spaces e , e^1 are formed which are entirely separate one from the other. If the partition is also connected to the backwall g of the retort, two entirely separate retort chambers are obtained, which permit also alternate charging, which in some cases may be of advantage.

In Fig. 4 a space i or i^1 remains between the partition d and the top or the bottom, respectively. Also it is not necessary for the partition to extend throughout the entire length of the retort, since a similar space may be left also between the rear end of the partition and the backwall g and the forward end of the partition and the door f , respectively. In this case the interior of the retort forms one single room or chamber, having uniform temperature, pressure and other conditions.

It has already been stated that the brickwork for the retort may be omitted entirely when the novel process is applied. A further advantage of the novel process consists in that it is possible, after the supply of the heat transmitting medium has been disconnected, to make a cooling medium circulate in the circulation system for the heat transmitting medium, as soon as the carbonization process is completed and the carbonized material is to cool down.

It is evident that the tubes and circulation conduits for the heat transmitting medium or the cooling medium, respectively, are connected one to the other in such a manner that the circulation of the heating or cooling media takes place automatically or by forced motion. In case the circulating tubes for the heating medium are arranged at the inside of the retort wall, the cooling process may be effected in this manner that the outside surface of the retort, which should be absolutely smooth in this case, is irrigated with water as a cooling medium or that cold air is passed over this surface by means of a blower or the like. In general, however, it will be more advisable, as indicated above, to pass a cooling

medium through the circulating system and conduits themselves after disconnecting the supply of the heat transmitting medium. Suitable stop-valves o , o' , o'' etc., permit instantaneous throttling of the circulation of the heat transmitting medium. Corresponding stopping devices permit the circulation of the cooling medium.

In Figs. 3 and 4 the partitions d are for example made of two plates d^1 and d^2 , in which traverses or cross-pieces s are so disposed that the subdivision into conduits or channels is obtained for the circulation of the heating or cooling medium. Fig. 5 illustrates this modification, which may also be applied to the outside walls of the retort. This illustration is on an exaggerated scale.

In Fig. 6 is represented a further modification, in which the retort wall or also the partitions d consist of a number of tubes c^3 which may be for example of square shape and are installed side by side and connected by means of welding.

In order to dispose of the tar which is produced in considerable quantities as a by-product when some kinds of wood are carbonized in the retort, the retort is provided at its bottom over the entire length with a tar gutter k having a small amount of inclination, if necessary, in the direction of discharge. The liquid tar will be separated out under the influence of the heat, cooled in the lowly placed gutter and discharged into a syphon or hydraulic closure receptacle. In order to assure the continuous discharge of the tar, any narrow tubes and other devices easily choked by tar should be strictly avoided. The large diameter tube n^1 of device n is submerged into the tar in receptacle n to such an extent that the tar, which acts as a hydraulic closure, will prevent any air from entering the retort. On the other hand, the level of the hydraulic closure liquid (tar) may be adjusted so that any escaping of carbonization gases from the retort is positively prevented. The tar is discharged from the retort by way of the apertures l , l^1 , etc. at the bottom (Figs. 1, 2, 3 and 4) and can be drained by means of the tube n^2 . The whole gutter k as well as the receptacle n may be covered by means of a shell m or n^3 , respectively, in order to be able to cool or heat the tar at will.

In case the retort is subdivided into two separate compartments e and e^1 , two tar gutters k may be provided (Fig. 2) or as indicated in Figs. 3 and 4, only one tar gutter k is used. The tar gutter may be arranged at an incline towards or away from the backwall g , according to the requirements of the distillation process.

Figs. 8 and 9 will show that the bottom of the retort may with advantage run down obliquely towards the tar gutter 13 , this arrangement offering also the advantage that the tar is already at the bottom 12 at a continuously increasing distance from the bottom tubes 2 and cannot be easily decomposed any more by the heat radiated by the tubes.

As will be apparent from the above specification, the invention entirely obviates the ill-defined conditions hitherto prevailing in heating retorts of this type. Instead, an absolutely safe and well-controlled way of heating the retort by means of a heat transmitting medium, which is heated in a heat generator, is secured and a perfect control of the temperatures is assured. The

temperature may also be changed by changing the number of the heating conduits in their entirety or only at certain regions of the retort and by reducing or increasing thereby the effect of heat radiation accordingly. By dividing the core or block of the material to be treated the carbonizing or distilling process is greatly accelerated in speed. The troublesome carbonization of the tar and the choking of valves or other checking devices is absolutely precluded by the use of the hydraulic closure device. The quality of the distillation products is improved in so far as an excessive heating of the mantel surrounding the retort, which mantel is otherwise heated by the fire or combustion gases, cannot take place and, consequently, the yield or rendement from the material to be carbonized is improved and the output increased because decomposition and retrograde formations or reactions of the distillation products will not occur. The direction of flow of the heat transmitting medium may be changed at will and adapted to the purposes in question. The heat transmitting medium may circulate through the walls at uniform or counter current, i. e. either in the direction of the truck entering the retort with the charge or batch material to be treated, or in the opposite direction towards the door f .

The retort may be freely suspended from an iron construction, or it may be fixedly supported on the floor by providing suitable substructures at any portion of the retort.

While I have herein shown and described certain preferred embodiments of my invention, I wish it to be understood that I do not confine myself to all the precise details herein set forth by way of illustration, as modification and variation may be made without a departure from the spirit of the invention or exceeding the scope of the appended claims.

I claim:

1. In a low-temperature carbonizing retort, a distilling chamber, a partition erected within said distilling chamber and formed of a pair of spaced parallel metal plates, a system of substantially parallel cross pieces mounted in the space between said plates and dividing said space into passages, said passages being adapted to be connected to a source of heated fluid, the outer surfaces of the outer walls of said distilling chamber being provided with a plurality of integrally formed conduit elements forming with said outer surfaces passages for the passage of fluid therethrough and adapted to be connected for the circulation of heated fluid therethrough, and a tar gutter on the lower face of said distilling chamber connected with the interior of said distilling chamber for receiving tar formed therein.

2. A low-temperature carbonizing retort as set forth in claim 1 wherein said partition has its to the chamber walls and divide said chamber into separate non-communicating spaces.

3. A low-temperature carbonizing retort as set forth in claim 1 wherein said partition has its ends spaced from the chamber walls and the several areas into which said chamber is divided by said partition intercommunicate with each other.

PAUL HADAMOVSKY. 70