

(19)



(11)

**EP 1 855 559 B1**

(12)

**EUROPEAN PATENT SPECIFICATION**

(45) Date of publication and mention of the grant of the patent:  
**24.12.2014 Bulletin 2014/52**

(51) Int Cl.:  
**A45D 20/20** <sup>(2006.01)</sup> **A45D 20/40** <sup>(2006.01)</sup>

(21) Application number: **06735167.6**

(86) International application number:  
**PCT/US2006/005383**

(22) Date of filing: **16.02.2006**

(87) International publication number:  
**WO 2006/091458 (31.08.2006 Gazette 2006/35)**

**(54) DEVICE FOR THE TREATMENT OF HEAD HAIR BY MEANS OF HEAT**

Vorrichtung zur Behandlung von Kopfhaar mittels Wärme

DISPOSITIF DE THERMOTRAITEMENT CAPILLAIRE

(84) Designated Contracting States:  
**AT BE BG CH CY CZ DE DK EE ES FI FR GB GR HU IE IS IT LI LT LU LV MC NL PL PT RO SE SI SK TR**

(74) Representative: **Zetterer, Gerd et al**  
**P&G Manufacturing GmbH**  
**Frankfurter Strasse 145**  
**61476 Kronberg (DE)**

(30) Priority: **23.02.2005 DE 102005008553**

(56) References cited:  
**EP-A- 0 072 994 EP-A- 0 372 443**  
**EP-A- 0 695 520 DE-A1- 4 235 436**  
**FR-A- 933 324 JP-A- 59 209 306**

(43) Date of publication of application:  
**21.11.2007 Bulletin 2007/47**

(73) Proprietor: **Wella GmbH**  
**65824 Schwalbach am Taunus (DE)**

- **PATENT ABSTRACTS OF JAPAN vol. 2003, no. 10, 8 October 2003 (2003-10-08) & JP 2003 164320 A (PIJON:KK), 10 June 2003 (2003-06-10)**
- **PATENT ABSTRACTS OF JAPAN vol. 2002, no. 03, 3 April 2002 (2002-04-03) & JP 2001 314225 A (PIJON:KK), 13 November 2001 (2001-11-13)**

(72) Inventor: **LIEBECK, Martin**  
**64295 Darmstadt (DE)**

**EP 1 855 559 B1**

Note: Within nine months of the publication of the mention of the grant of the European patent in the European Patent Bulletin, any person may give notice to the European Patent Office of opposition to that patent, in accordance with the Implementing Regulations. Notice of opposition shall not be deemed to have been filed until the opposition fee has been paid. (Art. 99(1) European Patent Convention).

## Description

**[0001]** The present invention relates to a device according to the characteristics in the preamble of Claim 1 as disclosed in EP 0372443A.

**[0002]** Such devices for the treatment of head hair by means of heat are known in various embodiments in so-called open configurations and are used in hair styling salons, as are known for example from EP0372443A2, EP0156984A1, and EP0072994A1.

**[0003]** The device as recited by US-D477,111-S uses five so-called emitter wells. These contain quartz tubes for the production of infrared radiation and reflectors made from aluminum. These [reflectors] together with the correct positioning of the emitter wells with respect to each other will ensure the required heat distribution for dyeing, perm and conditioning treatments. In order for to give the maximum possible freedom of movement and a feeling of openness to a customer under the heat treatment device, the distance between the two emitter wells in the lateral arms should be approx. 18 in (460 mm). Furthermore, the arrangement includes one well in the neck region, one to the upper rear above the back of the head and one toward the upper front over the front of the customer's head.

**[0004]** EP 0372443A, FR 933324A and JP 59209306A propose devices for the heat treatment of the head hair of a person with lateral heat emitters which are adjustable in two directions (in a horizontal and vertical plane) providing for the required relative movements between lateral and third and fourth emitters, JP 2003164320A proposes a lateral arm foldable by a lag hinge and DE 4235436A1 proposes multiple alternative mechanisms for the displacement of two lateral emitters.

**[0005]** A substantial disadvantage of the above-described device is that the heat treatment results are unsatisfactory when relatively large curlers are used.

**[0006]** The underlying object of the present invention is to produce a device of this same type that does not exhibit the above-described disadvantages.

**[0007]** This object is achieved by the characteristic features of Claim 1. Additional embodiments of the present invention as recited in Claim 1 arise from the sub-claims.

**[0008]** This device with infrared radiation and support blowers configured as a heat treatment device for hair styling techniques for use in drying operations is characterized by the device being readily changed over during the course of a hair styling procedure between two treatments [such as] between a heat treatment device with an open heating region (first operational position A1) and a drying device with a significantly more enclosed drying region (though with a higher heat energy density) (second operational position A2), where the two lateral emitter wells mounted so as to be on either side of the head can be shifted or pivoted in the direction of the emitter wells [that are] upward and rearward. Thus, an intensive and rapid drying of the head hair 2 can be achieved in the second operational position, such as with a conven-

tional hair drying hood (such as is known, for example, in GB1348683B1).

**[0009]** The positioning of the two emitter wells mounted laterally so as to be on both sides of the head can be selectively modified by folding the lateral arms and by tilting the emitter wells, for example up to 180 degrees.

**[0010]** The distance between the two emitter wells mounted laterally so as to be on both sides of the head is approx. 18 in (460 mm) (first operational position) during the heat treatment operation and approx. 13 in (320 mm) (second operational position) during the drying operation.

**[0011]** The present invention will be explained in more detail by means of several embodiments with the help of Fig. 1 through 17. In the drawings:

- Fig. 1 shows a front view of a device in a first operational position;
- Fig. 2 shows a perspective side view of the device of Fig. 1;
- Fig. 3 shows a view on the left side of the device of Fig. 1;
- Fig. 4 shows a top view of the device of Fig. 1;
- Fig. 5 shows a view from behind the device of Fig. 1;
- Fig. 6 shows a view from the front of the device in a second operational position;
- Fig. 7 shows a perspective side view of the device of Fig. 6;
- Fig. 8 shows a view on the left side of the device of Fig. 6;
- Fig. 9 shows a top view of the device of Fig. 6;
- Fig. 10 shows a view from behind the device of Fig. 6;
- Fig. 11 shows an exploded view of the left- and right-hand swivel arms with the respective lateral emitters in the first operational position;
- Fig. 12 shows a lateral perspective of the left- and right-hand swivel arms of Fig. 11;
- Fig. 13 shows a view from behind the swivel arms of Fig. 11;
- Fig. 14 shows the swivel arms of Fig. 11 in the second operational position;
- Fig. 15 shows the swivel arms of Fig. 12 in the second operational position;
- Fig. 16 shows the swivel arms of Fig. 13 in the second operational position, and
- Fig. 17 shows the device of Fig. 2 with the lateral emitters removed.

**[0012]** The Figures show device 1 for the heat treatment of head hair 2 of person 3 that include first and second heat emitters 11, 12, that are constituted from left-hand lateral emitter 4 and right-hand lateral emitter 5 oriented opposite each other for supplying heat 6 to the lateral head hair 7, where third, fourth and fifth heat emitters 13, 14, 15 are oriented for the heat treatment of the remaining head hair. All of heat emitters 11 through 15 are arranged in a so-called open configuration for the purpose of unrestricted handling and observation of head

hair 2 and more extensive visibility for person 3 during the heat treatment. A minimum of two lateral emitters 4, 5 are configured to be selectively adjustable from a first operational position A1 (Fig. 1) with first distance a between one another to a second operational position A2 (Fig. 6) with second distance b between one another by means of first respective mechanism 8, where the second distance b is smaller than the first distance a.

**[0013]** The two lateral emitters 4, 5 exhibit a first distance a (Fig. 1) of approx. 18 in (460 mm) in the first operational position A1. In the second operational position A2, the two lateral emitters 4, 5 exhibit a second distance b (Fig. 6) of approx. 13 in (320 mm), whereby an intensive drying effect on head hair 2 takes place.

**[0014]** At a minimum, the two lateral emitters 4, 5 are selectively configured to shift from the first operational position A1 to the second operational position A2 and back again by means of first mechanism 8.

**[0015]** At a minimum, the two lateral emitters 4, 5 are configured to be hinged so as to shift between first operational position A1 and second operational position A2 by means of first mechanism 8 through corresponding lag hinge 9 on swivel arm 10. The lag hinges 9, 9 are mounted within housing 30 of device 1 (Fig. 3).

**[0016]** By means of first mechanism 8, at least two lateral emitters 4, 5 are configured to be manually adjustable from a first operational position A1 to a second operational position A2 and back again. At least two lateral emitters 4, 5 are configured so that they can be selectively adjusted with first mechanism 8 by motor.

**[0017]** At least two lateral emitters 4, 5 communicate with a position monitoring mechanism not further depicted for automatic monitoring of a preset first operational position A1 or second operational position A2, in order to ensure the safe operation of the respective provided operational positions A1, A2. The corresponding monitoring and signaling of operational position A1 takes place when it is established whether first distance a (Fig. 1) of the two lateral emitters 4, 5 and third and fourth distances c, d (Fig. 3) are set. The corresponding monitoring and signaling of operational position A2 takes place when it is established whether second distance b (Fig. 6) of the two lateral emitters 4, 5 and the fifth and sixth distances e, f (Fig. 8) are set.

**[0018]** Third, fourth and fifth heat emitters 13, 14, 15 are arranged in such a manner that heat 6 is supplied to head hair 2 by third heat emitter 13 in rear region 17, by fourth heat emitter 14 in upper rear region 18 and fifth heat emitter 15 in an upper front region 19.

**[0019]** All heat emitters 11 through 15 exhibit the respective configuration of rounded well 20. Well 20 has diameter D of approx. 10 in (250 mm).

**[0020]** All heat emitters 11 through 15 are provided with respective ring-shaped infrared emitter element 21, pan ring reflector 22 and with blower 23.

**[0021]** The two lateral emitters 4, 5 exhibit respectively two infrared emitter element half-rings 24, 25 that can be controlled with electric energy independently from one

another. In this way, the heat exposure of head hair 2 (long hair/short hair) can be controlled.

By means of a respective second mechanism 26, the two lateral emitters 4, 5 can be positioned in such a way that in first operational position A1 (in addition to first distance a of the two lateral emitters 4, 5 with respect to each other as in Fig. 1), they will exhibit third distance c to third heat emitter 13 and a fourth distance d for fourth heat emitter 14 (Fig. 3). In second operational position A2 according to Fig. 8, the two lateral emitters 4, 5 will exhibit a fifth, closer distance e to third heat emitter 13 and a sixth, closer distance f to fourth heat emitter 14, whereby both lateral emitters 4, 5 and third and fourth heat emitters 13, 14 are positioned closer to head hair 2 and thus achieve a substantially higher drying effect.

**[0022]** Second mechanism 26 exhibits respective pivot joint 27 for tilting the two lateral emitters 4, 5 by approx. 180 degrees from first operational position A1 to second operational position A2. The tilting by means of eccentric bearing 28 on lateral emitters 4, 5 takes place manually here, by means of respective adjustment knob 16 on lateral emitters 4, 5. In operational position A1 the two lateral emitters 4, 5 are positioned toward the front with adjustment knobs 16, 16 (Fig. 2). In the other operational position A2, the two lateral emitters 4, 5 are positioned toward the rear with adjustment knobs 16, 16 (Fig. 7), whereby a closer distance of all heat emitters 11 through 15 arises and thus an intensive drying of head hair 2 is achieved.

**[0023]** Figs. 11 through 16 show various perspectives in exploded view, in particular lag hinges 9, 9, where Fig. 11 shows the left-hand and right-hand swivel arms 10, 10 with left-hand and right-hand lateral emitters 4, 5 in first operational position A1.

**[0024]** Fig. 12 shows a lateral perspective on the left-hand and right-hand swivel arms 10, 10 of Fig. 11.

**[0025]** Fig. 13 shows a view from behind of swivel arms 10, 10 of Fig. 11.

**[0026]** Fig. 14 shows swivel arms 10, 10 of Fig. 11 in second operational position A2.

**[0027]** Fig. 15 shows swivel arms 10, 10 of Fig. 12 in second operational position A2.

**[0028]** Fig. 16 shows swivel arms 10, 10 of Fig. 13 in second operational position A2.

**[0029]** Fig. 17 shows device 1 of Fig. 2 with lateral emitters 4, 5 removed, wherein pivot bearing 27 is more easily recognizable as a mounting for eccentric bearing 28 of left-hand lateral emitter 4.

**[0030]** In Figs. 4, 5, and 9 through 17, all of heat emitters 11 through 15 are provided with a respective protective cover 29 that prevents any contact with infrared emitter elements 21.

**[0031]** Operating and monitoring panel 31 is configured for the operating and monitoring of device 1 (Figs. 3 through 5, and 8 through 10), where power cable 32 (Fig. 3) serves as a power source for device 1. Support pin 33 (Fig. 3) is provided for the positioning of device 1 and to connect it with a support (not shown).

**List of reference numbers:****[0032]**

1	device	5
2	head hair	
3	person	
4	left-hand lateral emitter	
5	right-hand lateral emitter	
6	heat	10
7	lateral head hair	
8	first mechanism	
9	lag hinge	
10	swivel arm	
11	first heat emitter	15
12	second heat emitter	
13	third heat emitter	
14	fourth heat emitter	
15	fifth heat emitter	
16	adjustment knob	20
17	rear region/head hair 2	
18	upper rear region/head hair 2	
19	upper front region/head hair 2	
20	well	
21	infrared emitter element	25
22	pan ring reflector	
23	blower	
24	first infrared emitter element half-ring	
25	second Infrared emitter element half-ring	
26	second mechanism	30
27	pivot joint	
28	eccentric bearing	
29	protective cover	
30	housing	
31	control and monitoring panel	35
32	power cable	
33	support pin	
A1	first operational position	
A2	second operational position	
a	first distance	40
b	second distance	
c	third distance	
d	fourth distance	
e	fifth distance	
f	sixth distance	45
D	diameter/well 20	

**Claims**

1. A device (1) for the heat treatment of the head hair (2) of a person (3) comprising first and second swivel arms (10) provided with first and second heat emitters (11, 12) constituted from a left-hand lateral emitter (4) and a right-hand lateral emitter (5) arranged opposite to one another for the supplying of heat (6) to the lateral head hair (7), and at least one third heat emitter (13) is arranged for the heat treatment of the

remaining head hair, where all of the heat emitters (11, 12 and 13) are arranged in a so-called open configuration for the purpose of unrestricted handling and observation of the head hair (2) and more extensive visibility for the person (3) during the heat treatment, where at least two lateral emitters (4, 5) are configured to be selectively adjustable from a first operational position (A1) with a first distance (a) between one another to a second operational position (A2) with a second distance (b) between one another by means of a respective first mechanism (8) for folding the respective swivel arm, **characterised in that** the second distance (b) is smaller than the first distance (a), **in that** the third heat emitter (13) and fourth and fifth heat emitters (14, 15) are configured in such a way that the head hair (2) receives heat (6) that is supplied from the third heat emitter (13) to the rear region (17), from the fourth heat emitter (14) to the upper rear region (18) and from the fifth heat emitter (15) to the upper forward region (19), **in that** two lateral emitters (4, 5) can respectively be positioned by means of a second mechanism (26) in such a manner that in the first operational position (A1) they exhibit a third distance (c) to the third heat emitter (13) and a fourth distance (d) to the fourth heat emitter (14) and in the second operational position (A2) they exhibit a fifth, closer distance (e) to the third heat emitter (13) and a sixth, closer distance (f) to the fourth heat emitter (14), where the second mechanism (26) respectively exhibits a pivot joint (27) for tilting the two lateral emitters (4, 5) from the first operational position (A1) to the second operational position (A2) and back again, and that the two lateral emitters (4, 5) exhibit selective respective adjustment knobs (16) for manual tilting.

2. The device as recited in Claim 1, wherein the two lateral emitters (4, 5) exhibit a first distance (a) of approx. 18 in (460 mm) in the first operational position (A1) and exhibit a second distance (b) of approx. 13 in (320 mm) in the second operational position (A2).

3. The device as recited in Claim 1, wherein the first mechanism (8) is constituted as a lag hinge (9).

4. The device as recited in Claim 1, wherein at least two lateral emitters (4, 5) are constituted to be manually adjustable by means of the first mechanism (8).

5. The device as recited in Claim 1, wherein at least two lateral emitters (4, 5) are constituted to be adjustable by motor by means of the first mechanism (8).

6. The device as recited in Claim 1, wherein at least two lateral emitters (4, 5) communicate with a posi-

tion monitoring mechanism to monitor a preset operational position (A1) or second operational position (A2).

7. The device as recited in Claim 1, wherein all of the heat emitters (11 through 15) respectively exhibit the configuration of a round well (20), preferably with a diameter (D) of approx. 250 mm.
8. The device as recited in Claim 1, wherein all of the heat emitters (11 through 15) respectively are provided with a ring-shaped infrared emitter element (21) and a pan ring reflector (22).
9. The device as recited in Claim 1, wherein all of the heat emitters (11 through 15) respectively are provided with a blower (23).
10. The device as recited in Claim 1, wherein the two lateral emitters (4, 5) respectively exhibit two infrared emitter element half-rings (24, 25) that are controlled with electrical energy independently from one another.

#### Patentansprüche

1. Vorrichtung (1) zur Wärmebehandlung des Kopfhaars (2) einer Person (3), umfassend erste und zweite Schwenkarme (10), die mit ersten und zweiten Wärmestrahlern (11, 12) bereitgestellt sind, die durch einen linken lateralen Strahler (4) und einen rechten lateralen Strahler (5) ausgebildet sind, die einander gegenüberliegend angeordnet sind, um dem lateralen Kopfhaar (7) Wärme (6) zuzuführen, wobei mindestens ein dritter Wärmestrahler (13) für die Wärmebehandlung des restlichen Kopfhaars angeordnet ist, wobei alle Wärmestrahler (11, 12 und 13) zwecks einer uneingeschränkten Handhabung und Beobachtung des Kopfhaars (2) und größeren Sichtbarkeit für die Person (3) während der Wärmebehandlung in einer sogenannten offenen Konfiguration angeordnet sind, wobei mindestens zwei laterale Strahler (4, 5) von einer ersten Betriebsposition (A1) mit einem ersten Abstand (a) dazwischen in eine zweite Betriebsposition (A2) mit einem zweiten Abstand (b) dazwischen mittels eines jeweiligen ersten Mechanismus (8) zum Umklappen des jeweiligen Schwenkarms selektiv verstellbar konfiguriert sind, **dadurch gekennzeichnet, dass** der zweite Abstand (b) kleiner als der erste Abstand (a) ist, dass der dritte Wärmestrahler (13) und der vierte und der fünfte Wärmestrahler (14, 15) derart konfiguriert sind, dass das Kopfhaar (2) Wärme (6) aufnimmt, die von dem dritten Wärmestrahler (13) dem hinteren Bereich (17), von dem vierten Wärmestrahler (14) dem oberen hinteren Bereich (18) und von dem fünften Wärmestrahler (15) dem oberen vorderen Be-

reich (19) zugeführt wird, dass zwei laterale Strahler (4, 5) jeweils mittels eines zweiten Mechanismus (26) derart positioniert werden können, dass sie in der ersten Betriebsposition (A1) einen dritten Abstand (c) zu dem dritten Wärmestrahler (13) und einen vierten Abstand (d) zu dem vierten Wärmestrahler (14) aufweisen und sie in der zweiten Betriebsposition (A2) einen fünften, näheren Abstand (e) zu dem dritten Wärmestrahler (13) und einen sechsten, näheren Abstand (f) zu dem vierten Wärmestrahler (14) aufweisen, wobei der zweite Mechanismus (26) jeweils ein Drehgelenk (27) zum Kippen der zwei lateralen Strahler (4, 5) von der ersten Betriebsposition (A1) in die zweite Betriebsposition (A2) und wieder zurück aufweist, und dass die zwei lateralen Strahler (4, 5) jeweilige selektive Einstellknöpfe (16) zum manuellen Kippen aufweisen.

2. Vorrichtung nach Anspruch 1, wobei die zwei lateralen Strahler (4, 5) einen ersten Abstand (a) von ungefähr 460 mm (18 in) in der ersten Betriebsposition (A1) und einen zweiten Abstand (b) von ungefähr 320 mm (13 in) in der zweiten Betriebsposition (A2) aufweisen.
3. Vorrichtung nach Anspruch 1, wobei der erste Mechanismus (8) als ein Schwenkscharnier (9) ausgebildet ist.
4. Vorrichtung nach Anspruch 1, wobei mindestens zwei laterale Strahler (4, 5) mittels des ersten Mechanismus (8) manuell verstellbar ausgebildet sind.
5. Vorrichtung nach Anspruch 1, wobei mindestens zwei laterale Strahler (4, 5) mittels des ersten Mechanismus (8) motorisch verstellbar ausgebildet sind.
6. Vorrichtung nach Anspruch 1, wobei mindestens zwei laterale Strahler (4, 5) mit einem Positionsüberwachungsmechanismus kommunizieren, um eine voreingestellte Betriebsposition (A1) oder zweite Betriebsposition (A2) zu überwachen.
7. Vorrichtung nach Anspruch 1, wobei alle Wärmestrahler (11 bis 15) jeweils die Konfiguration einer runden Vertiefung (20) aufweisen, die vorzugsweise einen Durchmesser (d) von ungefähr 250 mm aufweist.
8. Vorrichtung nach Anspruch 1, wobei alle Wärmestrahler (11 bis 15) jeweils mit einem ringförmigen Infrarotstrahlerelement (21) und einem pfannenringförmigen Reflektor (22) bereitgestellt sind.
9. Vorrichtung nach Anspruch 1, wobei alle Wärmestrahler (11 bis 15) mit einem Gebläse (23) bereitgestellt sind.

10. Vorrichtung nach Anspruch 1, wobei die zwei lateralen Strahler (4, 5) jeweils zwei Infrarotstrahlerelement-Halbringe (24, 25) aufweisen, die unabhängig voneinander mit elektrischer Energie gesteuert werden.

### Revendications

1. Dispositif (1) pour le traitement thermique des cheveux (2) d'une personne (3) comprenant des premier et deuxième bras pivotants (10) pourvus de premier et deuxième émetteurs de chaleur (11, 12) constitués d'un émetteur latéral gauche (4) et d'un émetteur latéral droit (5) disposés face à face pour fournir de la chaleur (6) à la région latérale des cheveux (7) et d'au moins un troisième émetteur de chaleur (13) conçu pour le traitement thermique du reste des cheveux, où tous les émetteurs de chaleur (11, 12 et 13) sont disposés dans une configuration dite ouverte dans le but de ne pas gêner la manipulation et l'observation des cheveux (2) et procurer une meilleure visibilité à la personne (3) pendant le traitement thermique, dans lequel au moins deux émetteurs latéraux (4, 5) sont conçus de façon à être sélectivement réglables entre une première position de fonctionnement (A1) avec une première distance (a) entre eux et une deuxième position de fonctionnement (A2) avec une deuxième distance (b) entre eux au moyen d'un premier mécanisme (8) respectif pour rabattre le bras pivotant respectif, **caractérisé en ce que** la deuxième distance (b) est plus petite que la première distance (a), **en ce que** le troisième émetteur de chaleur (13) et les quatrième et cinquième émetteurs de chaleur (14, 15) sont conçus de telle sorte que les cheveux (2) reçoivent la chaleur (6) qui est fournie par le troisième émetteur de chaleur (13) au niveau de la région arrière (17), par le quatrième émetteur de chaleur (14) au niveau de la région arrière supérieure (18) et par le cinquième émetteur de chaleur (15) au niveau de la région supérieure avant (19), **en ce que** deux émetteurs latéraux (4, 5) peuvent respectivement être positionnés au moyen d'un deuxième mécanisme (26) de telle manière que dans la première position de fonctionnement (A1), ils présentent une troisième distance (c) par rapport au troisième émetteur de chaleur (13) et une quatrième distance (d) par rapport au quatrième émetteur de chaleur (14), et que dans la deuxième position de fonctionnement (A2), ils présentent une cinquième distance (e) plus courte par rapport au troisième émetteur de chaleur (13) et une sixième distance (f) plus courte par rapport au quatrième émetteur de chaleur (14), le deuxième mécanisme (26) présentant respectivement une articulation (27) permettant de faire basculer les deux émetteurs latéraux (4, 5) de la première position de fonctionnement (A1) à la deuxième position de fonctionnement (A2)

et vice-versa, et **en ce que** les deux émetteurs latéraux (4, 5) présentent des boutons de réglage sélectif respectifs (16) pour l'inclinaison manuelle.

- 5 2. Dispositif selon la revendication 1, dans lequel les deux émetteurs latéraux (4, 5) présentent une première distance (a) de 460 mm (18 po.) environ dans la première position de fonctionnement (A1) et présentent une deuxième distance (b) de 320 mm (13 po.) environ dans la deuxième position de fonctionnement (A2).
- 10 3. Dispositif selon la revendication 1, dans lequel le premier mécanisme (8) est constitué comme une articulation de rabattement vers l'arrière (9).
- 15 4. Dispositif selon la revendication 1, dans lequel au moins deux émetteurs latéraux (4, 5) sont conçus pour être réglables manuellement au moyen du premier mécanisme (8).
- 20 5. Dispositif selon la revendication 1, dans lequel au moins deux émetteurs latéraux (4, 5) sont conçus pour être réglables par moteur au moyen du premier mécanisme (8).
- 25 6. Dispositif selon la revendication 1, dans lequel au moins deux émetteurs latéraux (4, 5) communiquent avec un mécanisme de suivi de position pour contrôler une position de fonctionnement pré réglée (A1) ou une deuxième position de fonctionnement (A2).
- 30 7. Dispositif selon la revendication 1, dans lequel tous les émetteurs de chaleur (11 à 15) présentent respectivement la configuration d'un puits circulaire (20) ayant, de préférence, un diamètre (D) de 250 mm environ.
- 35 8. Dispositif selon la revendication 1, dans lequel tous les émetteurs de chaleur (11 à 15) sont respectivement pourvus d'un élément émetteur infrarouge en forme d'anneau (21) et d'un réflecteur annulaire parabolique (22).
- 40 9. Dispositif selon la revendication 1, dans lequel tous les émetteurs de chaleur (11 à 15) sont respectivement pourvus d'un ventilateur soufflant (23).
- 45 10. Dispositif selon la revendication 1, dans lequel les deux émetteurs latéraux (4, 5) présentent respectivement deux éléments émetteurs infrarouges en demi-anneau (24, 25) commandés par l'énergie électrique indépendamment l'un de l'autre.
- 50
- 55

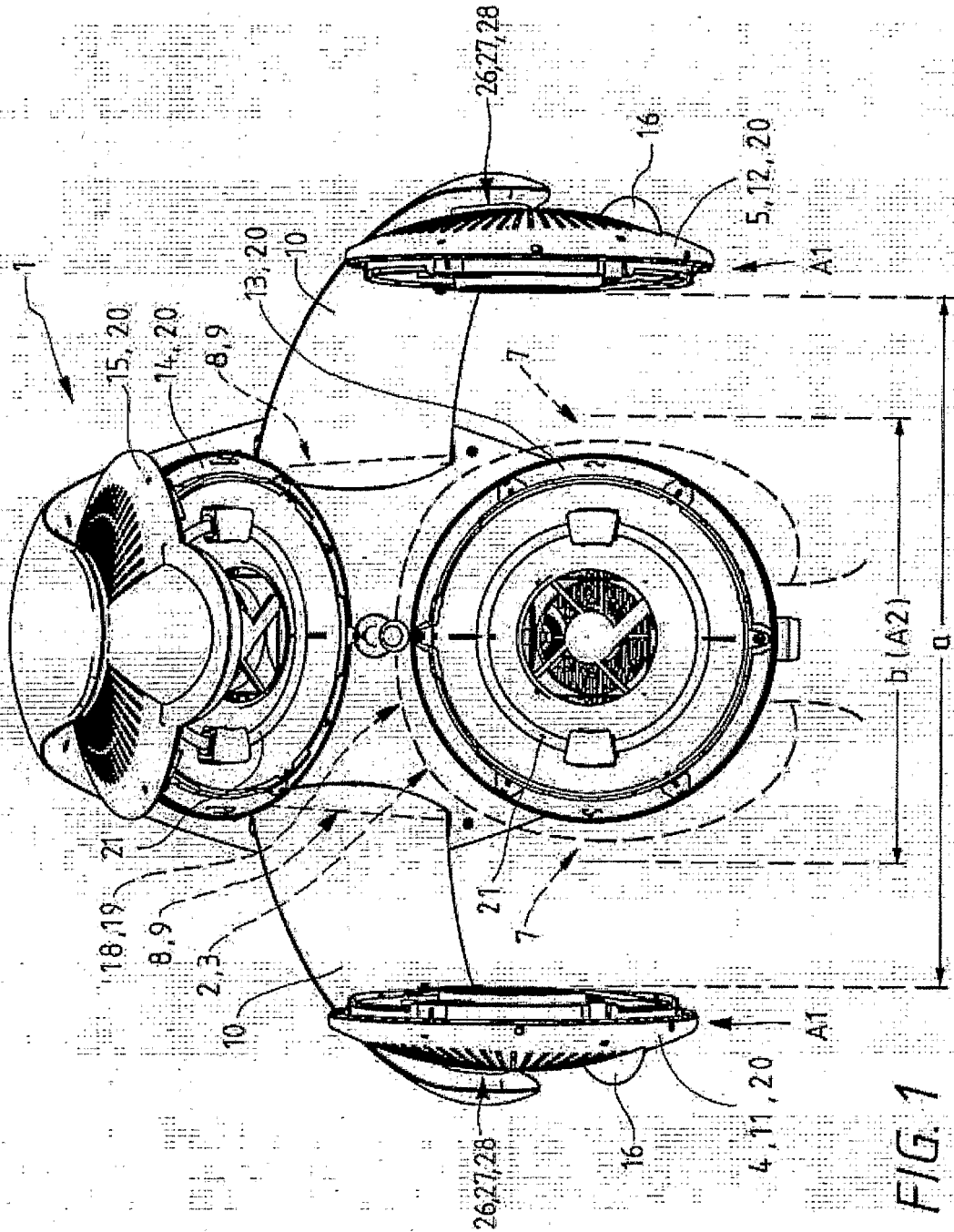

FIG. 1

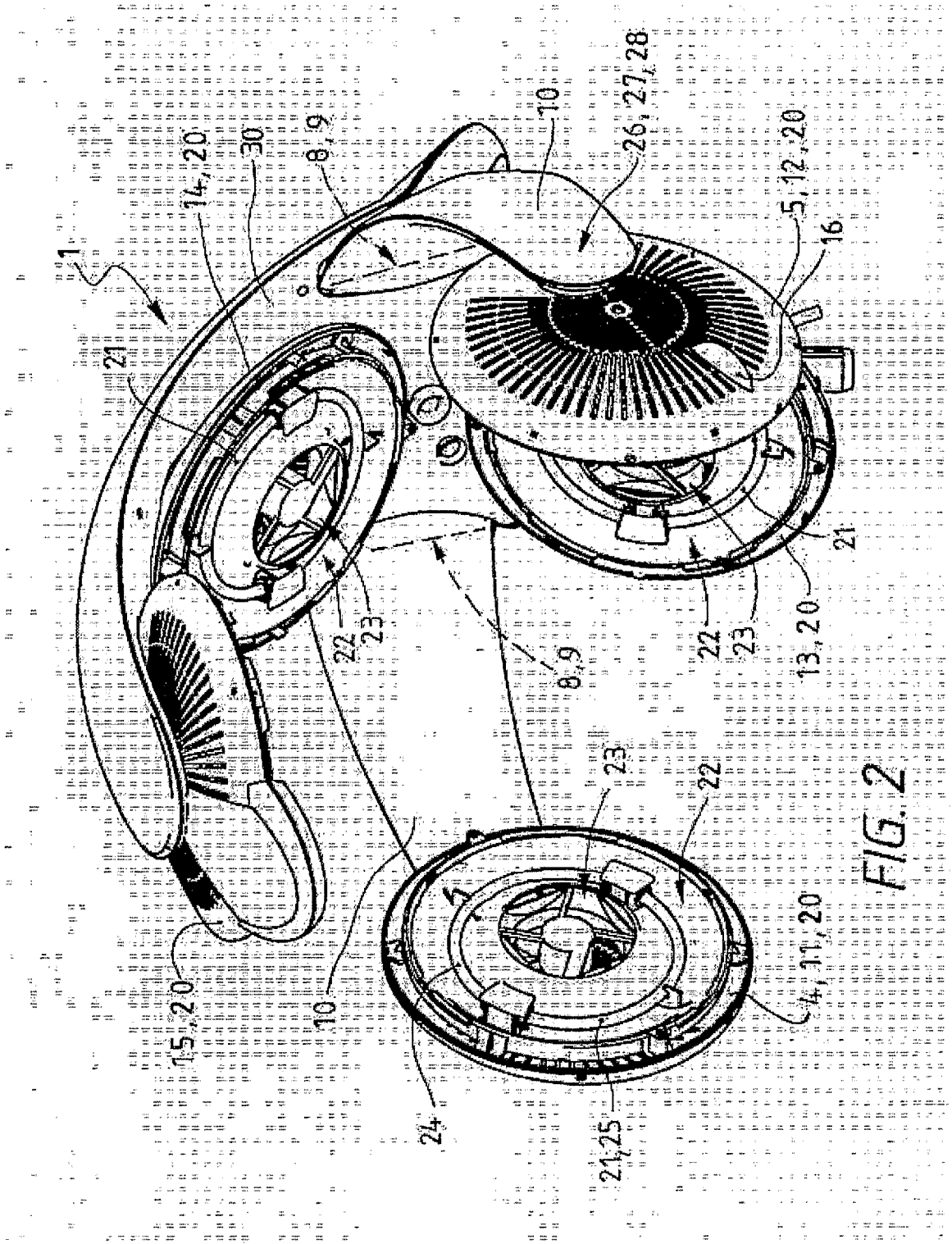

FIG. 2

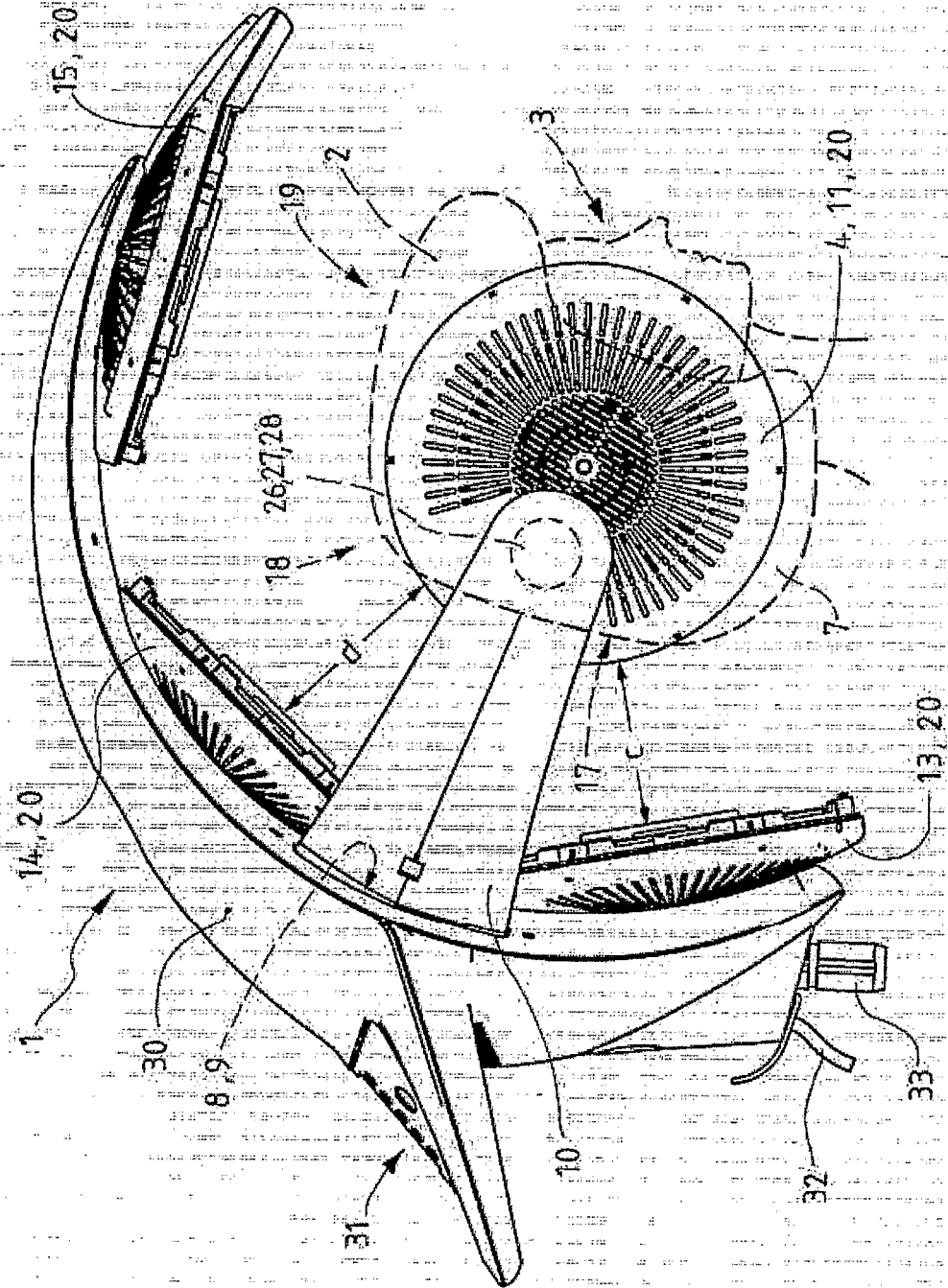

FIG. 3

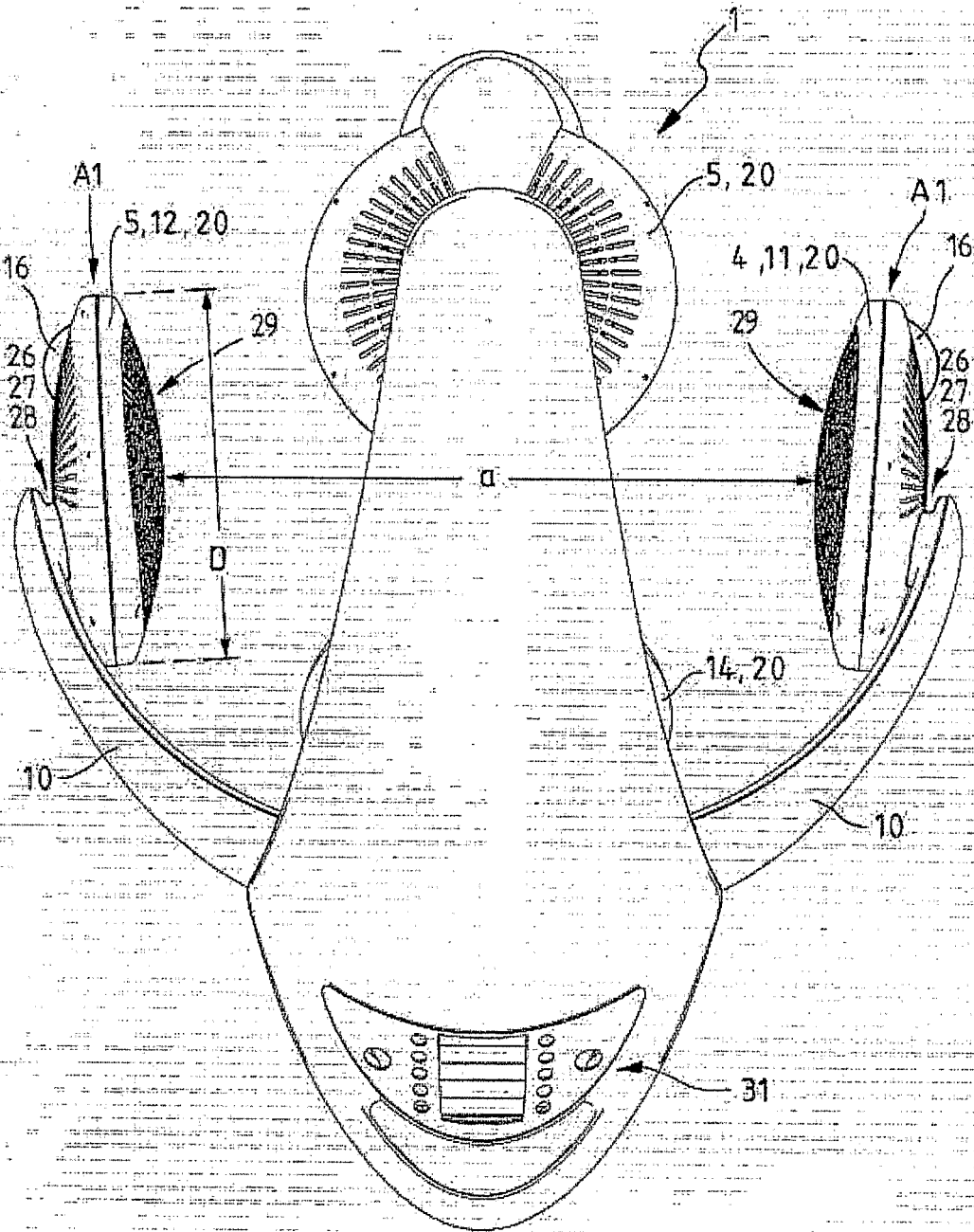

FIG. 4

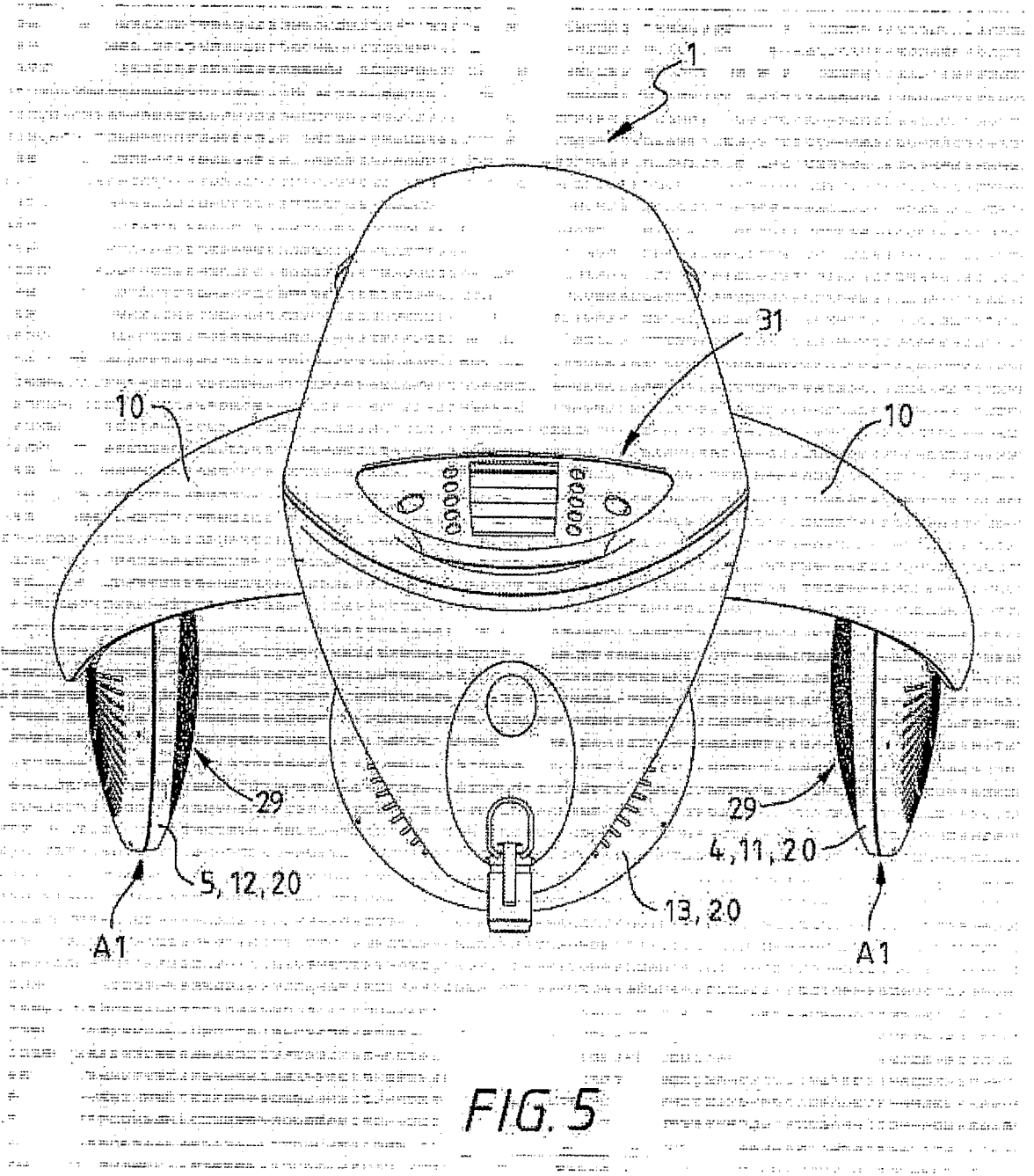

FIG. 5

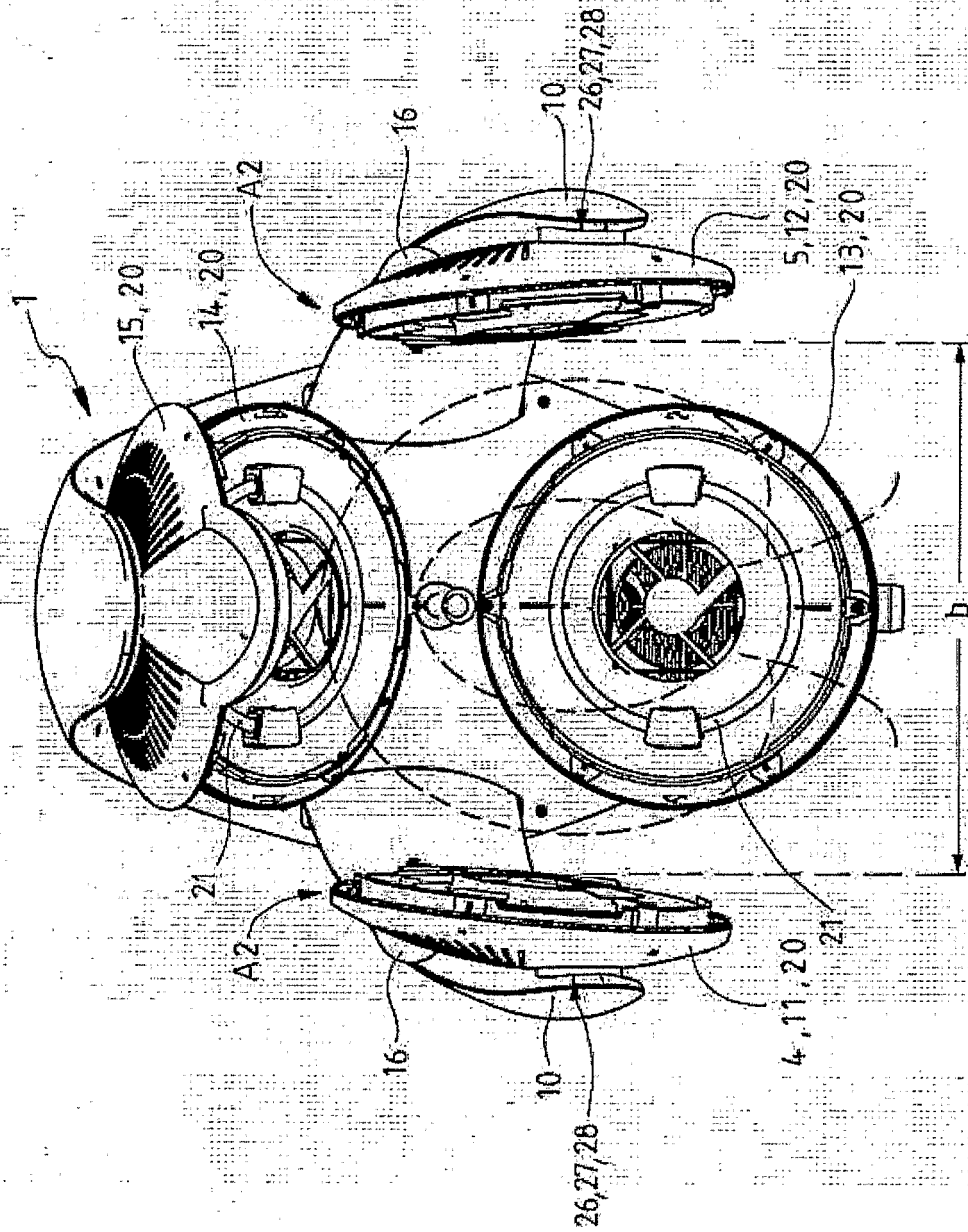

FIG. 6

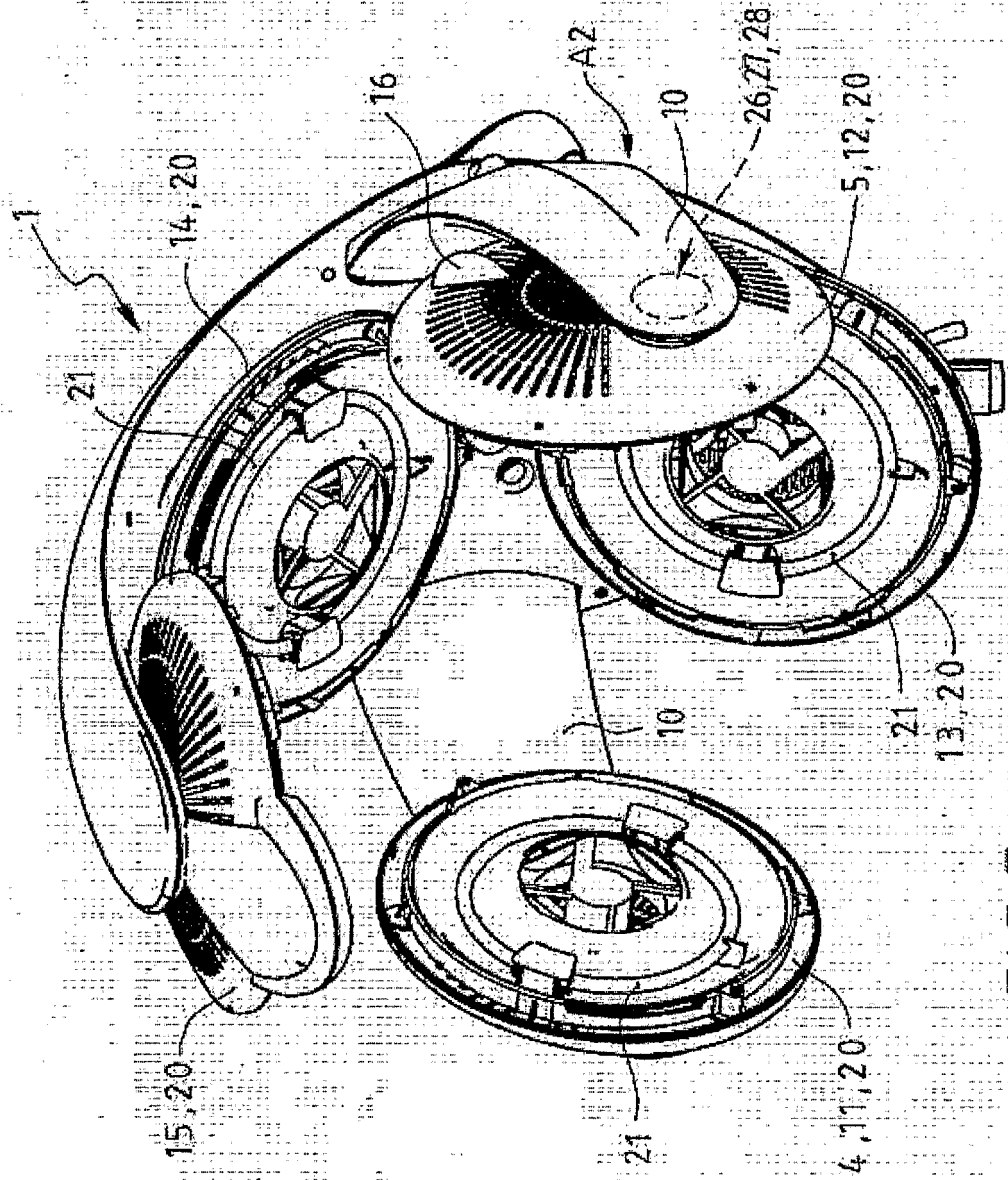

FIG. 7

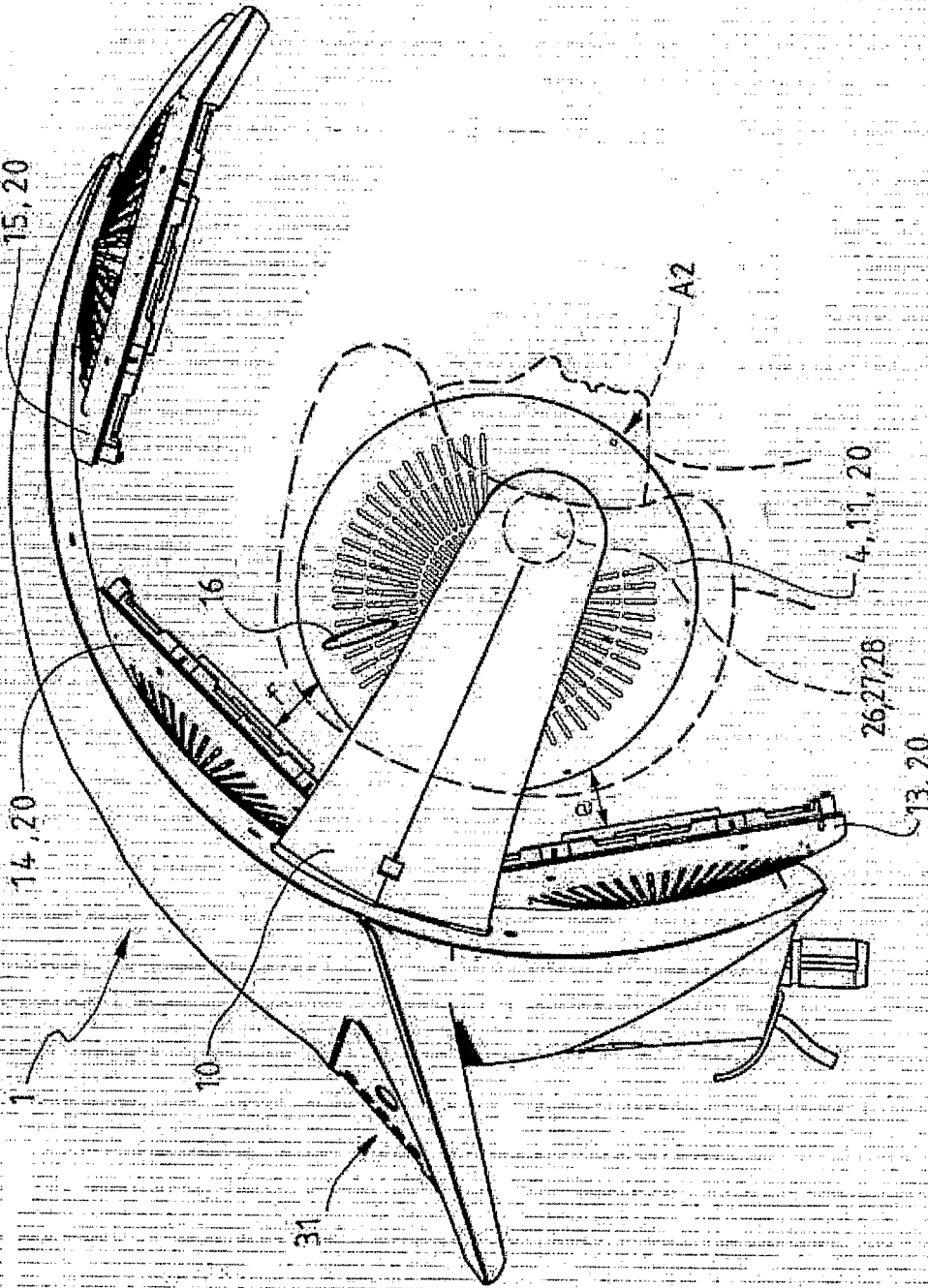

FIG. 8

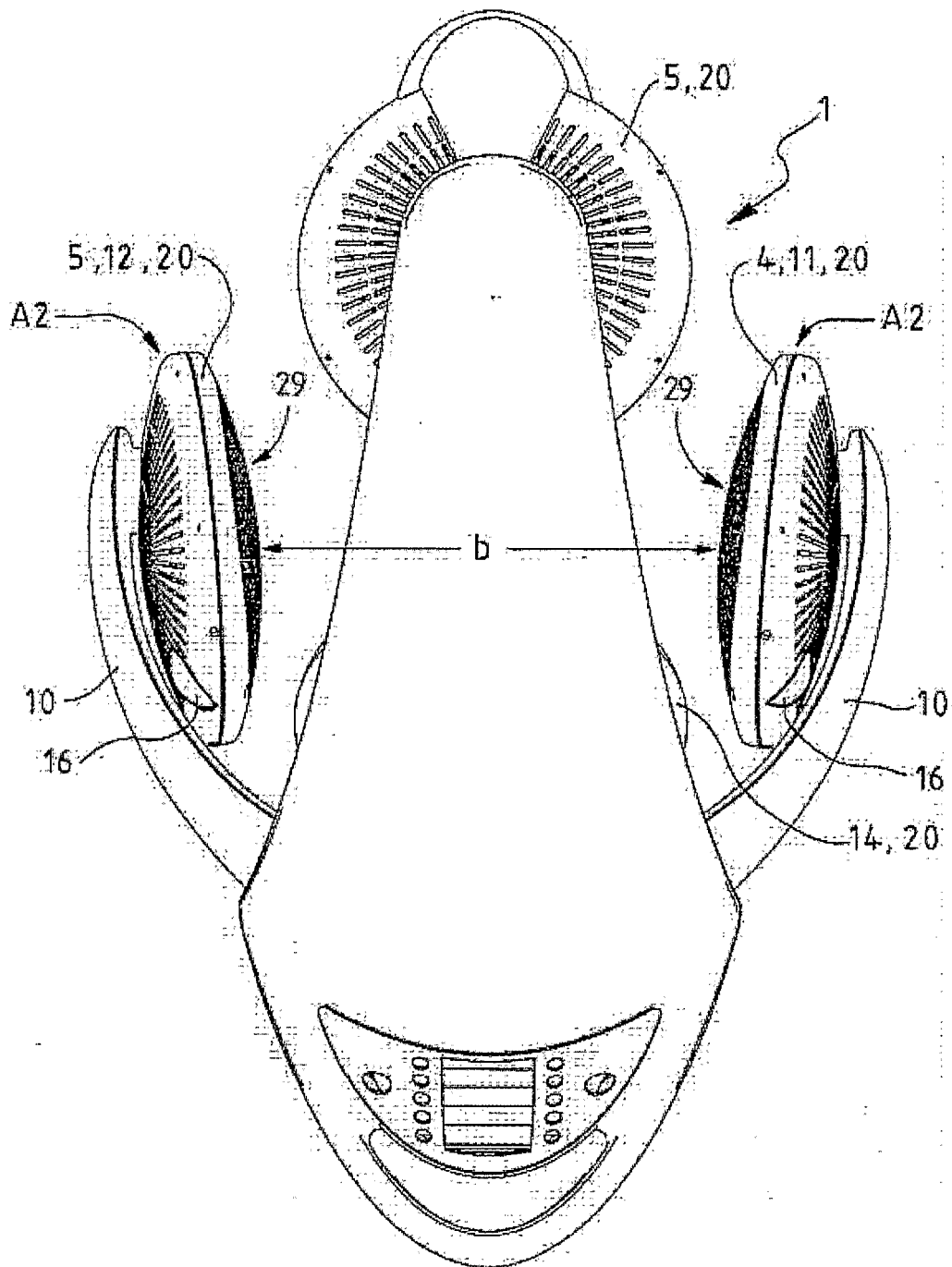

FIG. 9

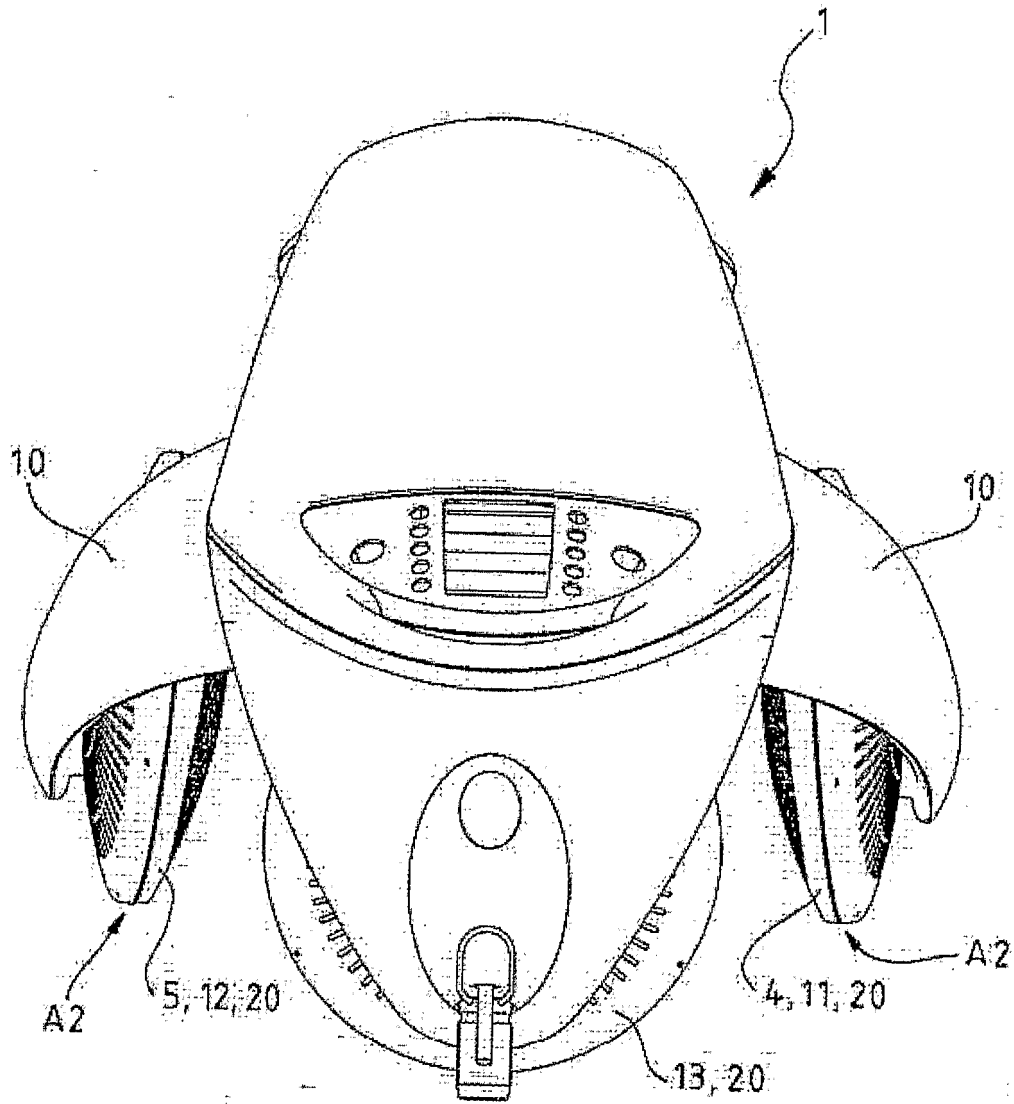

FIG. 10

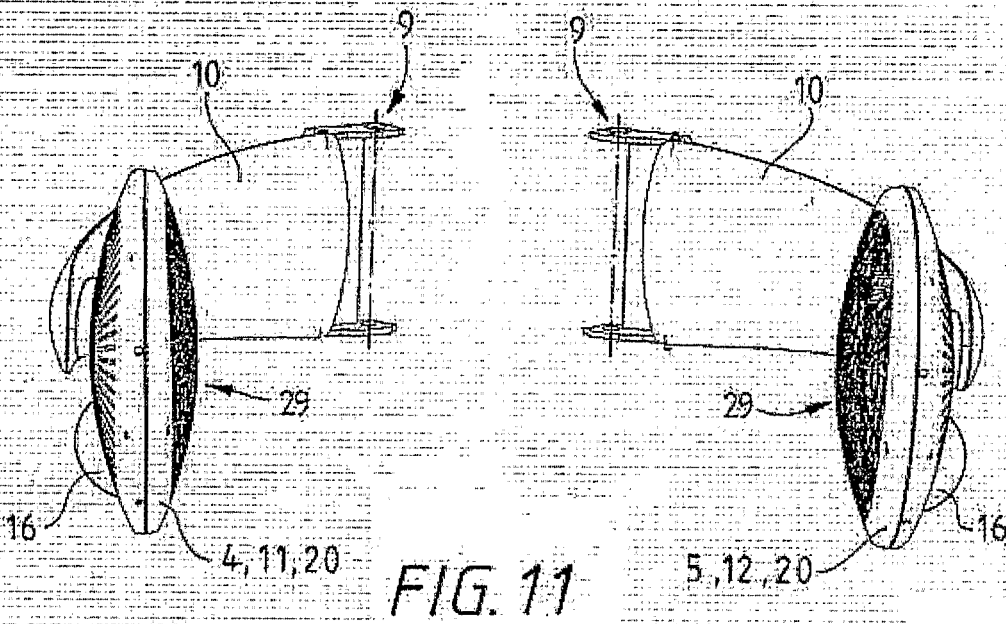

FIG. 11

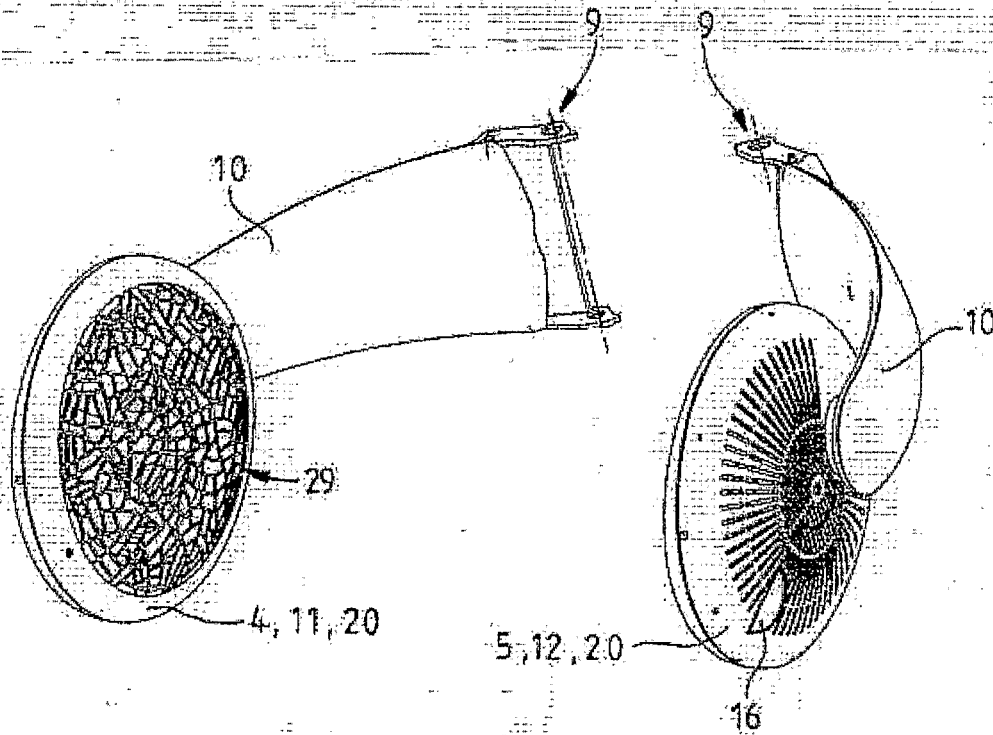

FIG. 12

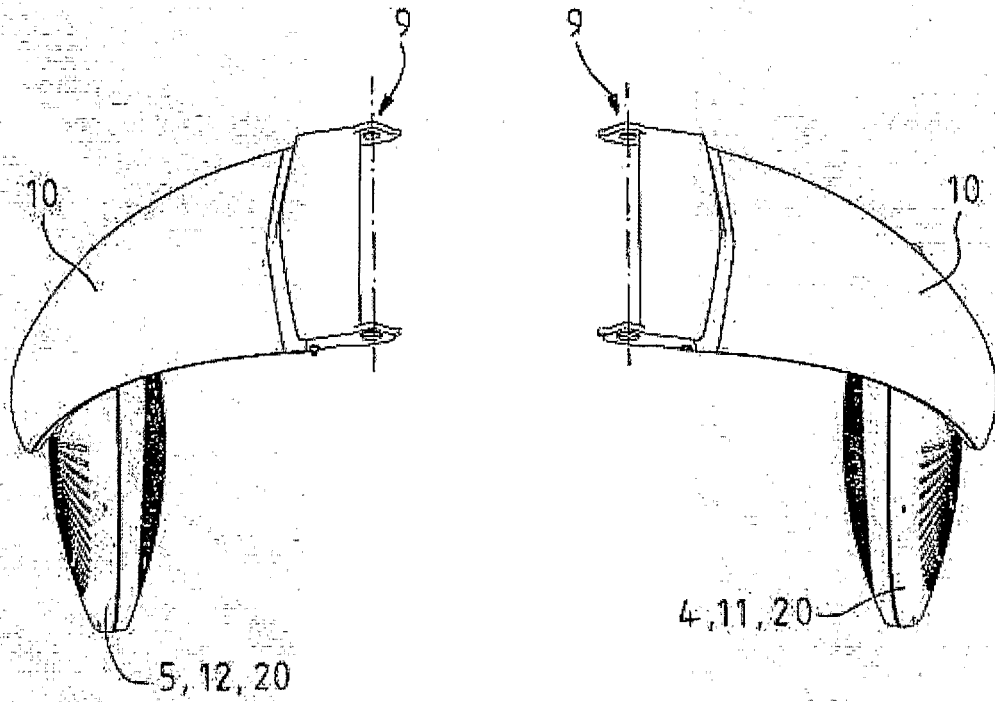

FIG. 13

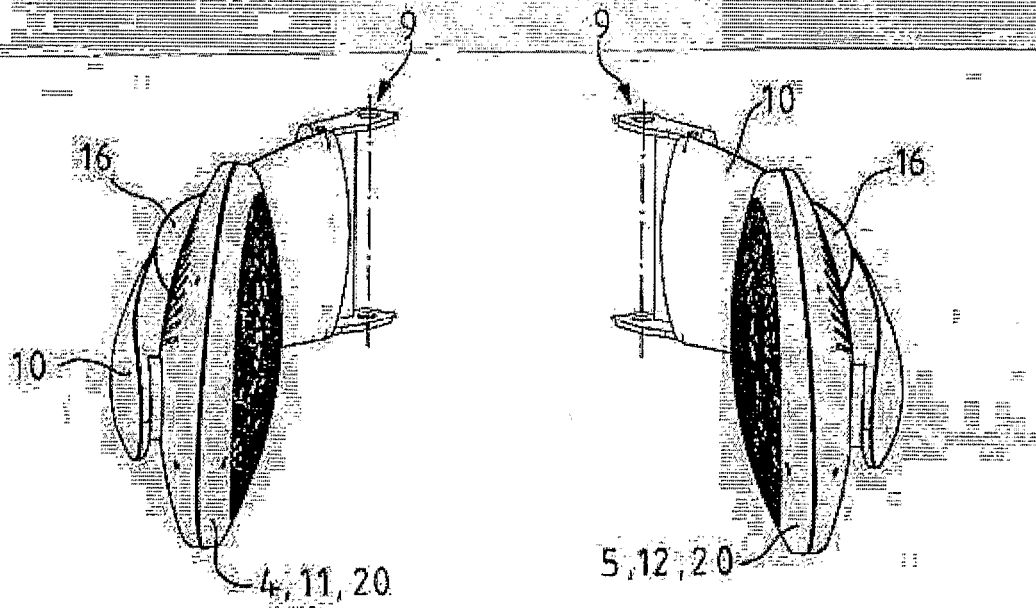

FIG. 14

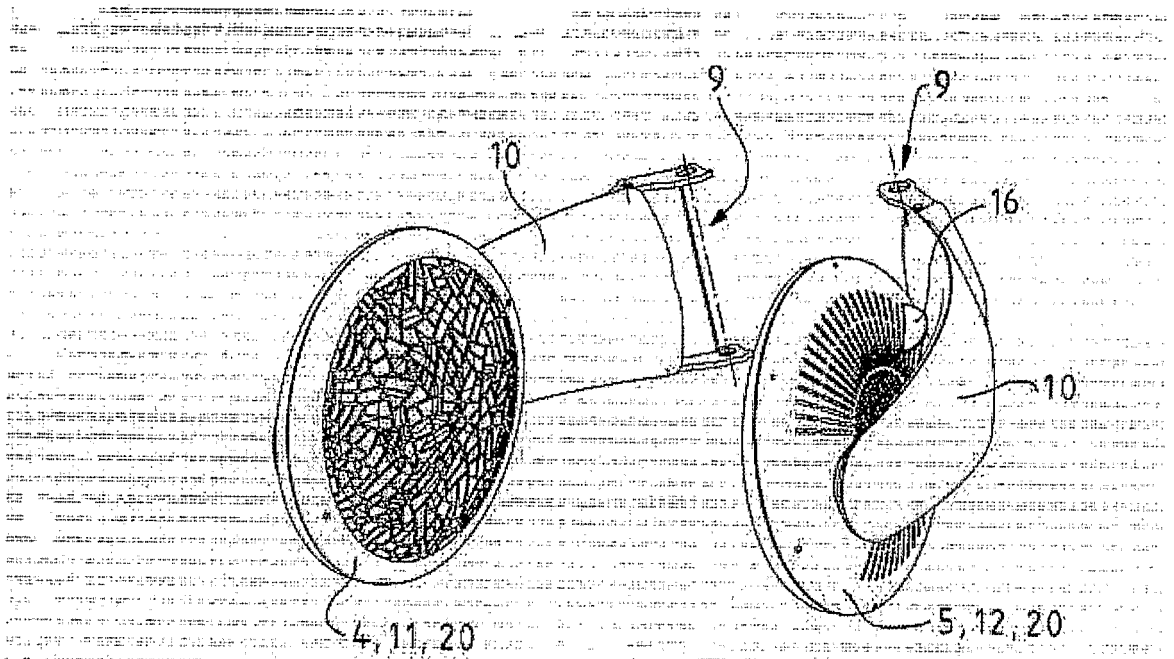

FIG. 15

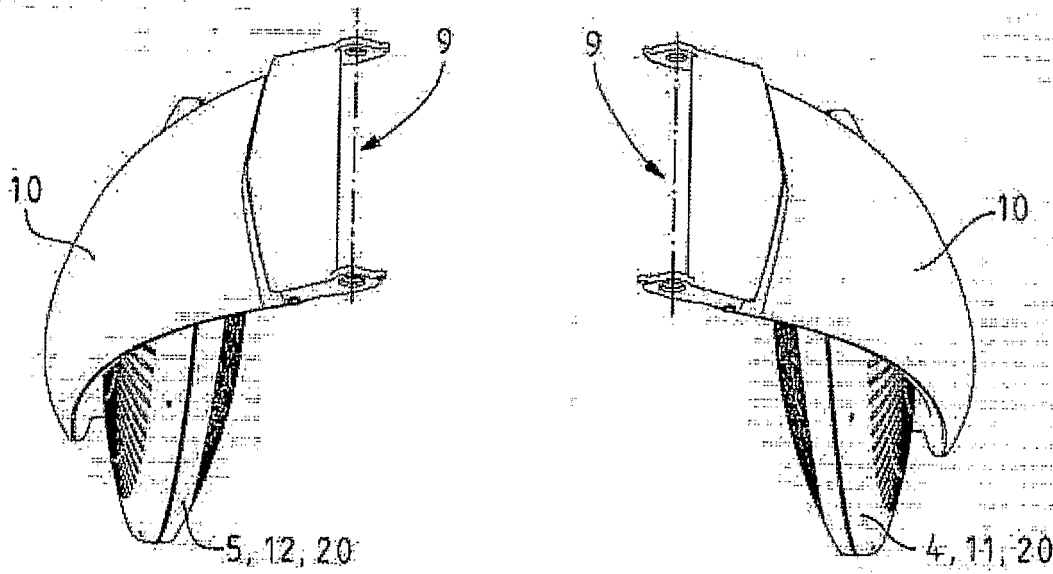

FIG. 16

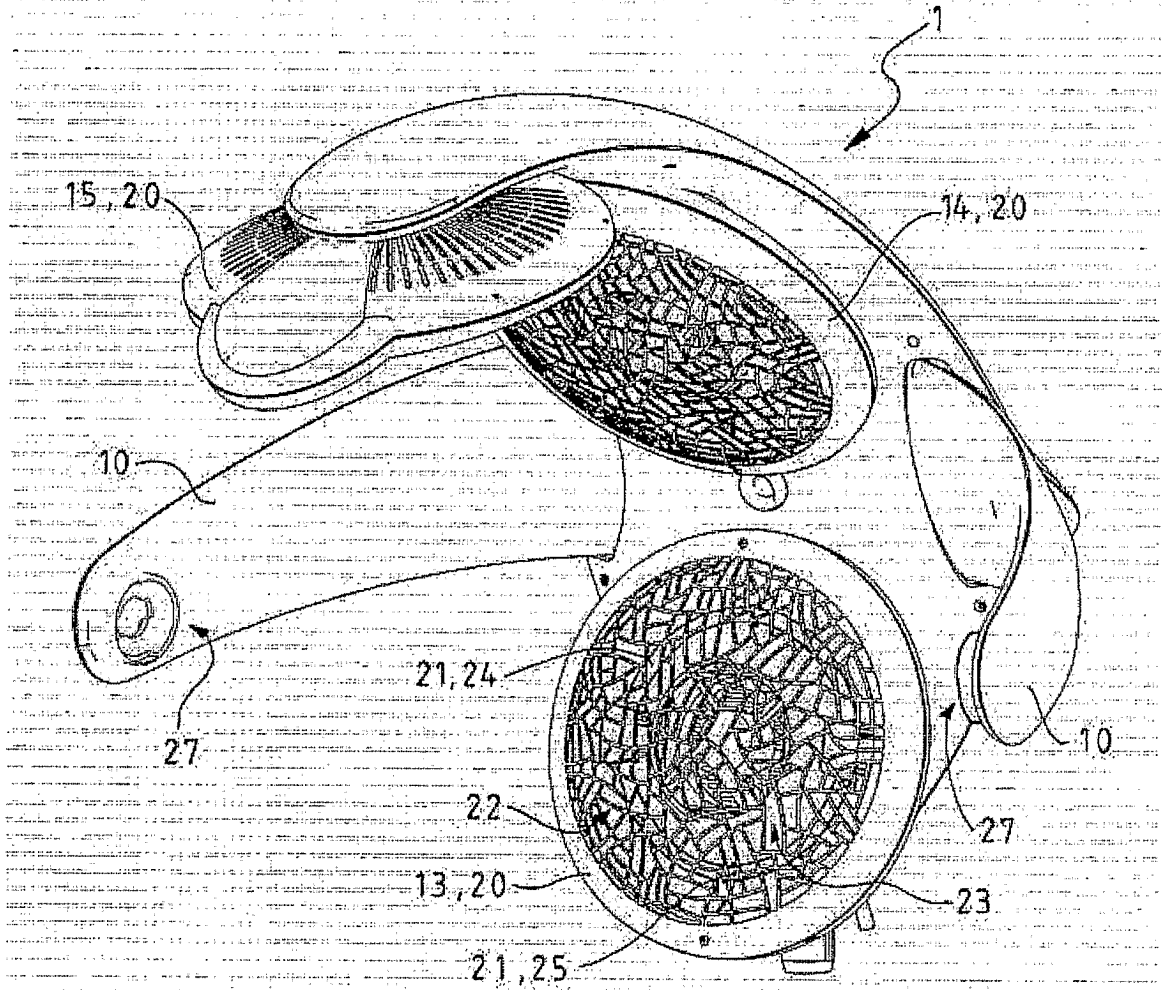

FIG. 17

**REFERENCES CITED IN THE DESCRIPTION**

*This list of references cited by the applicant is for the reader's convenience only. It does not form part of the European patent document. Even though great care has been taken in compiling the references, errors or omissions cannot be excluded and the EPO disclaims all liability in this regard.*

**Patent documents cited in the description**

- EP 0372443 A [0001] [0004]
- EP 0372443 A2 [0002]
- EP 0156984 A1 [0002]
- EP 0072994 A1 [0002]
- US D477111S S [0003]
- FR 933324 A [0004]
- JP 59209306 A [0004]
- JP 2003164320 A [0004]
- DE 4235436 A1 [0004]
- GB 1348683 B1 [0008]