



- (51) International Patent Classification:
H03F 1/32 (2006.01)
- (21) International Application Number:
PCT/US2016/064127
- (22) International Filing Date:
30 November 2016 (30.11.2016)
- (25) Filing Language:
English
- (26) Publication Language:
English
- (30) Priority Data:
14/953,762 30 November 2015 (30.11.2015) US
- (71) Applicant: NANOSIMI TECHNOLOGY [US/US]; 135
Beaver Street Suite 203, Waltham, MA 02452 (US).
- (72) Inventors: KIM, Helen, H.; 16 Maynard Farm Circle,
Sudbury, MA 01776 (US). MEGRETSKI, Alexandre;
146 Ministerial Drive, Concord, MA 01742 (US). YAN,
Li; 87 Bridge Street, Lexington, MA 02421 (US). KEVIN,
Chuang; 655 Concord Ave, Unit 505, Cambridge, MA
02138 (US). MAHMOOD, Zohaib; 120 Kingston Street,
Unit 1810, Boston, MA 02111 (US).

- (74) Agent: ROHLICEK, J., Robin; Occhiuti & Rohlicek
LLP, 321 Summer Street, Boston, MA 02210 (US).
- (81) Designated States (unless otherwise indicated, for every
kind of national protection available): AE, AG, AL, AM,
AO, AT, AU, AZ, BA, BB, BG, BH, BN, BR, BW, BY,
BZ, CA, CH, CL, CN, CO, CR, CU, CZ, DE, DJ, DK, DM,
DO, DZ, EC, EE, EG, ES, FI, GB, GD, GE, GH, GM, GT,
HN, HR, HU, ID, IL, IN, IR, IS, JP, KE, KG, KN, KP, KR,
KW, KZ, LA, LC, LK, LR, LS, LU, LY, MA, MD, ME,
MG, MK, MN, MW, MX, MY, MZ, NA, NG, NI, NO, NZ,
OM, PA, PE, PG, PH, PL, PT, QA, RO, RS, RU, RW, SA,
SC, SD, SE, SG, SK, SL, SM, ST, SV, SY, TH, TJ, TM,
TN, TR, TT, TZ, UA, UG, US, UZ, VC, VN, ZA, ZM,
ZW.
- (84) Designated States (unless otherwise indicated, for every
kind of regional protection available): ARIPO (BW, GH,
GM, KE, LR, LS, MW, MZ, NA, RW, SD, SL, ST, SZ,
TZ, UG, ZM, ZW), Eurasian (AM, AZ, BY, KG, KZ, RU,
TJ, TM), European (AL, AT, BE, BG, CH, CY, CZ, DE,
DK, EE, ES, FI, FR, GB, GR, HR, HU, IE, IS, IT, LT, LU,
LV, MC, MK, MT, NL, NO, PL, PT, RO, RS, SE, SI, SK,
SM, TR), OAPI (BF, BJ, CF, CG, CI, CM, GA, GN, GQ,
GW, KM, ML, MR, NE, SN, TD, TG).

[Continued on next page]

(54) Title: DIGITAL COMPENSATOR

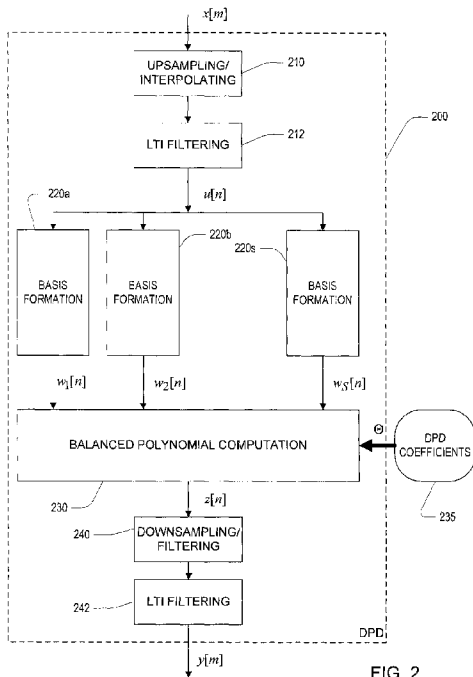

FIG. 2

(57) Abstract: An approach to digital compensation uses a particular structure for a digital pre-distorter (DPD) which acts as a relatively accurate pre-inverse of a non-linear circuit (e.g., a non linear transmit chain involving digital-to-analog converter (DAC), lowpass filter, modulator, bandpass filter, and power amplifier) while making use of a relatively small number of parameters that characterize the non-linearity and/or parameters that provide accurate linearization without requiring continual updating.

WO 2017/095869 A1

Published:

— *with international search report (Art. 21(3))*

DIGITAL COMPENSATOR

Cross Reference to Related Applications

This application claims the benefit of the filing date of U.S. Application No. 14/953,762, filed November 30, 2015, the entire content of which is incorporated herein by reference.

Background

[001] This invention relates to digital compensation of a non-linear circuit, and in particular, to linearization of a non-linear power amplifier and transmitter chain.

[002] A concept of applying a digital compensation to restore the quality of an original signal passed through a circuit is a routine. A power amplifier in a radio of a wireless base station or handset is compensated digitally in the baseband to minimize the spectral leakage into adjacent channels. An audio amplifier in a speaker is compensated digitally to achieve high fidelity. In many such examples, variants of Volterra series have been adopted to account for dynamical nature of nonlinearity. Wiener, Wiener-Hammerstein, General Memoryless Polynomial are popular structures for digital pre-distorters, which are used to modify an input signal prior to passing through a non-linear circuit. In general, these structures have an exponential complexity if the polynomial order exceeds 3 to 5, as well as robustness issues due to sensitivity of compensator parameters to variations of a particular device (Device Under Test, DUT), including process, temperature, supply voltage, and other operating conditions.

[003] Referring to FIG. 1, in an example of a linearization of a radio power amplifier, a digital input signal $x[n]$ at a baseband or intermediate frequency is passed through a Digital Pre-Distorter (DPD) 110 to produce a “pre-distorted” input $y[n]$, which is passed through a transmit chain 140 to produce a driving signal $p(t)$ that drives an antenna 150. The transmit chain may include a Digital-to-Analog Converter (DAC) 142, an analog lowpass filter (LPF) 144, and a modulator (e.g., multiplication by a local oscillator) of the output of the LPF 144. The output of the modulator is passed to a power amplifier (PA) 148. The PA 148, as well as other elements in the transmit chain, may introduce nonlinearities, which may be manifested in the driving signal $p(t)$ as harmonic and/or

intermodulation distortion of the input signal $x[n]$. To overcome these nonlinearities, the DPD 110 also introduces non-linearities that are intended to “pre-invert” (i.e. pre-distort) the non-linear effects of the transmit chain. In some examples, the DPD performs the transformation of the desired signal $x[n]$ to the input $y[n]$ of the transmit chain by using delay elements 120 to form a set of delayed versions of the desired signal, and then using a non-linear polynomial function 130 of those delayed inputs. In some examples, the non-linear function is a Volterra series:

$$y[n] = h_0 + \sum_p \sum_{\tau_1, \dots, \tau_p} h_p(\tau_1, \dots, \tau_p) \prod_{j=1 \dots p} x[n - \tau_j]$$

In some examples, the non-linear function is reduced set of Volterra terms, for example a delay polynomial:

$$y[n] = h_0 + \sum_p \sum_{\tau} h_p(\tau) x[n - \tau] |x[n - \tau|^{(p-1)}$$

[004] In order to invert the non-linear effects of the transmit chain, in general, a relatively large number of terms of such a series representation are needed, and the coefficients of those terms (e.g., the h_p terms) must be accurately set. In general, the coefficients in such approaches are continually updated to maintain good linearization. Various approaches to such continual updating are used, for example, based on incremental updates using $y[n]$ and observation of $p(t)$ (e.g., after demodulation).

Summary

[005] In a general aspect, an approach to digital compensation uses a particular structure for a digital pre-distorter (DPD) which acts as a relatively accurate pre-inverse of a non-linear circuit (e.g., a non-linear transmit chain involving digital-to-analog converter (DAC), lowpass filter, modulator, bandpass filter, and power amplifier) while making use of a relatively small number of parameters that characterize the non-linearity and/or parameters that provide accurate linearization without requiring continual updating.

[006] In general, this approach is more closely related to the underlying sources of non-linearity arising from the modulation and subsequent (e.g., non-linear) amplification of the modulated signal. In particular, the approach more directly captures harmonic and intermodulation distortion effects without requiring a large number of parameters.

[007] In one aspect, in general, a pre-distorter implements an overall non-linear transformation of a sampled input signal $u[n]$ (e.g., an upsampled version of a baseband

encoding of a desired signal to be transmitted) to yield an input $y[m]$ to a transmit chain. The overall non-linear transformation is implemented using a combination of time filtered versions of linear and non-linear functions of the input signal. In this description, these time filtered versions are referred to as basis functions of the input signal. Some examples of such basis functions include

$$w_i = G_i(f_i(u))$$

where $f_i(u)$ may be a non-linear function of u , for example, $|u|^k$, and $G_i(\)$ may be a linear time domain filtering.

[008] In some examples, a set of basis functions is combined using a “balanced polynomial” form, which can be expressed as:

$$y[n] = \sum_k a_k \left(\left(\prod_i (w_i[n])^{b_{k,i}} \right) \left(\prod_j (w_i^*[n])^{c_{k,j}} \right) \right)$$

where

$$\sum_i b_{k,i} = 1 + \sum_j c_{k,j}.$$

[009] In some cases, the exponents $\{b_{k,i}\}$ and $\{c_{k,j}\}$ are predetermined, and the parameters $\Theta = \{a_k\}$ are determined, for example, using various approaches to system identification.

[010] In some examples, the parameters for a device are determined prior to operation, for example, at a fabrication, manufacture, deployment, and/or periodic maintenance time, and then set for subsequent operation. In some examples, different sets of parameters are determined for different operating conditions (e.g., operating temperature, supply voltage, etc.), and in operation different sets of parameters are used according to sensing of the operating conditions. In some examples, external parameters such as temperature, supply voltage, output power, modulation mode, part age, sampling rate and part signature are inputs to a previously configured predictor unit. Based on these, the unit determines the regime of operation and outputs updated coefficients for the compensator. In some examples, the part signature is obtained by short fabrication-time characterization (e.g. few tones or a special transmit sequence).

[011] One or more approaches described above have advantages including reduced operation-time computation complexity, thereby reducing power requirements and use of other computation-related resources, while providing relatively accurate linearization (e.g., relative to other approaches that use comparable computation resources). By using a structure of the pre-distorter that matches the non-linear structure of the circuit, the number of coefficients needed to accurately linearize the system is reduced and these parameters are more robust to variation of the system, thereby avoiding the need to continually update the parameters based on the observation of the output signals (e.g. $p(t)$). Note that the predictor can continuously update the coefficients in response to, for example, temperature changes, or supply voltage changes.

[012] Other features and advantages of the invention are apparent from the following description, and from the claims.

Description of Drawings

[013] FIG. 1 is a block diagram of a conventional digital pre-distortion approach;

[014] FIG. 2 is a block diagram representing a number of embodiments of the present approach;

[015] FIG. 3 is a block diagram illustrates a coefficient interpolation approach;

[016] FIG. 4 is a block diagram that shows a operation-time parameter estimation approach;

[017] FIG. 5 is a block diagram that shows a pre-operation coefficient modeling approach;

[018] FIG. 6 is a block diagram showing a combined coefficient interpolation and operation time parameter estimation approach;

[019] FIG. 7 is a block diagram of an exemplary basis formation and polynomial combination embodiment; and

[020] FIG. 8 is a block diagram of an alternative basis formation approach incorporating normalization.

Description

[021] Referring to FIG. 2, a first embodiment of a Digital Pre-Distorter 200 accepts a desired input signal $x[m]$ in digital form (e.g., 12-14 bits per time sample), sampled at a sampling rate sufficient to represent the bandwidth (e.g., 20-120MHz) of the desired signal. In general, the input signal is complex, with the real and imaginary parts representing quadrature components of the signal to be transmitted. For example, the desired input is a baseband encoding (e.g., an OFDM encoding) of one or more channels of communication, for instance, for a cellular telephone transmitter (e.g., according to an LTE communication standard). The input signal is upsampled using a conventional upsampling/interpolation component 210, for example, in some embodiments by a factor equal to one plus the degree of nonlinearity of interest in the transmit chain divided by two (e.g., if nonlinearity of interest is 7th order, then upsampling by a factor of four is used), and then optionally filtered. Upsampling enables the DPD by shrinking the spectrum to avoid aliasing of undesirable harmonics in the target band.

[022] In some examples, an optional LTI (Linear Time Invariant) filtering component 212 processes the signal after upsampling. The LTI filter is selected to “mimic” the long-term behavior of the elements of the transmit chain 140, for example, for the DAC 142, the LPF 144, etc. For example the fixed-coefficient reconstruction filter mimics the zero-order hold properties of the DAC. The upsampled and filtered input signal $u(n)$ is then used to compute S basic signals, $w_1[n]$ through $w_s[n]$, each sampled at the upsampled rate, using a set of basis formation elements 220a-s, most of which represent non-linear transformations (e.g., polynomial function) of the input. The basis formation can incorporate polynomial function of the input, or alternatively non-polynomial function, for example, a polynomial $X|X|^2$, or a non-polynomial $(X|X|^2)/\text{avg}(|X|^2)$. The basis signals are applied to balanced polynomial computation element 230, or in alternative embodiments another form of non-linear combination, which outputs a combined signal $z[n]$ at the upsampled rate. This combined signal is then downsampled in a downsampling/filtering component 240, and optionally further filtered in a LTI filtering component 242, for example, yielding the original sampling rate of the input signal $x[m]$, to produce an output $y[m]$ of the DPD 200.

[023] Referring to FIG. 3, in some embodiments, the output $y[m]$ of the DPD 200 is passed through a transmit chain 140 to produce the driving signal $p(t)$ for the antenna 150 of the transmitter. As shown in FIGS. 2, the DPD 200, and more particularly the balanced polynomial computation is configured according to numerical parameters, the

DPD coefficients 235. In this embodiment, these coefficients are determined using a database of coefficients 344, and values that essentially characterize the operation “regime” (i.e., a class of physical conditions) of the transmit chain. These values (e.g., quantitative or categorical digital variables) include environment variables 342 (e.g., temperature, transmitter power level, supply voltage, frequency band) and/or a part “signature” 343, which represents substantially invariant characteristics and which may be unique to the electronic parts of the transmit chain 140. The coefficient interpolator 340 takes these inputs and the coefficient database and outputs corresponding DPD coefficients 235. A variety of approaches may be implemented by the coefficient interpolator, including selection and/or interpolation of coefficient values in the database according to the inputs, and/or applying a mathematical mapping of the input represented by values in the coefficient database.

[024] Referring to FIG. 4, in another embodiment, the DPD coefficients 235 are determined during operation of the system by using a receive chain 430 processes a sensing of the output $p(t)$, and through substantially linear demodulation, and digitization, produces a digital output $q[m]$ at the same sampling interval as the input $y[m]$ of the transmit chain. In some examples, the coefficients are adjusted in a substantially continuous manner during operation, while in other examples, the coefficients are updated relatively infrequently in batches (e.g., once an hour, day, etc.) using non-operational inputs. The determination of these parameters is discussed more fully below, and generally relies on sensing of an output of the transmit chain 140, and processing that sensed output using a receive chain 330, which is assumed to be substantially linear.

[025] Referring to FIG. 5, an approach to forming the coefficient database 344 (see FIG. 3) makes use of an analysis of the transmit chain 140 prior to operational use. More generally, a set of instances of transmit chains (e.g., using separately manufactured parts) are analyzed to sample manufacturing and other part-to-part variations. Generally, different test signals $x[m]$ are used to drive the transmit chain 140, and corresponding input $y[m]$ and received output $q[m]$ (i.e., after demodulating through the received chain 430), are used to estimate DPD coefficients 235 under various environmental conditions. The DPD coefficients 235 and corresponding environment variables 342 are provided to the coefficient modeler 560, which stores them (optionally pre-processing them, for example, for from a piecewise linear model) in the coefficient database 344.

[026] Continuing to refer to FIG. 5, each instance of the transmit chain may be characterized by passing specific test signals through the transmit chain 140 and using a signature measurement module 550 to determine signature values (e.g., quantitative or categorical values) from those measurements. For example, multi-tone test signals may be passed through the transmit chain and the magnitude of distortion products may be measured and recorded as elements of the part signature. As part of the manufacturing or other pre-operational stage, the part signature for a transmit chain is provided in association with that transmit chain, and used in operation, for example, as part signature 343 as illustrated in FIG. 3. For example, the part signature may be stored on a computer readable medium (e.g., non-volatile semiconductor memory) in, coupled to, or otherwise associated with the transmit chain or its components. When used by the DPD 200, the part signature imparts specific functionality on the DPD to compensate for non-linearities of the specific instance of the transmit chain.

[027] It should be understood that environment variables and signature variables may be used independently or in combination. Also, it should be understood that the coefficient interpolator 340 (e.g., FIG. 3) may implement various forms of interpolation or approximation as long as they are compatible with the coefficient modeler 560 (e.g., FIG. 5). Such techniques can include the use of a piecewise linear interpolation as a non-essential example. Other ways of mapping from the environment and signature variables include use of other piecewise smooth functions, kernel approach, etc..

[028] Referring to FIG. 6, yet another embodiment combines aspects shown in FIG. 3 and in FIG. 4, namely that the DPD coefficients 235 depend not only on an interpolation based on a coefficient database 344 and environment variables 342 and/or part signature 343, but also depend on feedback of sensed and demodulated via a receive chain 330 of the output of the transmit chain 140.

[029] Referring to FIG. 7, and also referring back to FIG. 2, the set of basis formation elements 220a-s include elements that can be represented as basis formation element 220i shown in FIG. 7. Generally, each such basis formation element includes a representative transformation element 410i and a (e.g., LTI) filter element 420i. The transformation elements are generally non-linear (e.g., polynomial) and memoryless, represented as $v_i[n] = f_i(u[n])$. Various functional forms may be used, for example, $f(u) = |u|^2$, $f(u) = |u|^3$, $f(u) = u|u|^2$, etc. The filter elements are generally linear and time invariant (LTI), for example, implementing one-pole or two-pole linear infinite-impulse-response (IIR) filters. For example, the poles of such filters may correspond to time constants of 1

to 4 samples and Q factors of 10. In general, at least some of the basis transformations include transformations (i.e., $v_i[n] = u[n]$) and/or pure delay filters (i.e., $w_i[n] = v_i[n - \tau]$) for one or more values of τ .

[030] Continuing to refer to FIG. 7, in some examples, the non-linear combination of the basis functions uses a balanced polynomial computation element 230, which can be represented in a general form as:

$$y[n] = H(w_1[n], \dots, w_S[n]) = \sum_k a_k \left(\left(\prod_i (w_i[n])^{b_{k,i}} \right) \left(\prod_j (w_i^*[n])^{c_{k,j}} \right) \right)$$

where for $w = a + jb$, where $j = \sqrt{-1}$, and $w^* = a - jb$ represents the complex conjugate of w , and therefore $w w^* = |w|^2$, and where for each term (k) the degree ($\sum_j b_{k,i}$) of the non-conjugated terms is one greater than the degree ($\sum_j c_{k,j}$) of the conjugated terms, that is

$$\sum_i b_{k,i} = 1 + \sum_j c_{k,j}$$

Examples of such functions include $H(w_1, w_2) = |w_1|^2 w_2 - 3w_1^2 w_2^*$ (i.e., $a_1 = 1$, $a_2 = -3$, $b_{1,1} = 1$, $b_{1,2} = 1$, $c_{1,1} = 1$, $c_{1,2} = 0$, $b_{2,1} = 2$, $b_{2,2} = 0$, $c_{2,1} = 0$, $c_{2,2} = 1$) and $H(w_1, w_2, w_3) = -j w_1 w_1 w_2^* + w_3$.

[031] Referring to FIG. 8, in some embodiments, some or all of the basis formation blocks 220a-s may use “non-polynomial” forms. For example, as illustrated in FIG. 8, a normalization block 820i may be used to normalize a basis value by dividing by an average value (e.g., a long time scale decaying average). It should be recognized that this type of normalization is only an example of a non-polynomial form of basis formation.

[032] Referring back to FIG. 2, the output $z[n]$ is then downsampled and filtered, for example, to the original sampling rate of the input $x[m]$ to yield the output $y[m]$. In some examples, this downsampling may be omitted, or the sampling rate of the output may be between the sampling rate of the input and the upsampled rate. In some examples, an optional LTI filtering stage 242 is applied at the output of the DPD 200 prior to passing the signal to the transmit chain.

[033] The structure of the DPD described above is robust to variation during operation and does not necessarily have to be adapted quickly during operation in order to maintain the linearization of the system. For example, the parameters for the DPD may be

estimated once for long periods of operation, for example, being estimated during manufacturing or deployment of the system.

[034] Referring back to FIG. 5, in an approach to estimation of the parameters Θ for the DPD, a receive chain 330 processes a sensing of the output $p(t)$, and through substantially linear demodulation, and digitization, produces an digital output $q[m]$ at the same sampling rate as the input $y[m]$ of the transmit chain. Note that as introduced above, this estimation may be used as part of formation of the coefficients of the database 344, and may also be used in operational adjustment of the coefficients as illustrated in FIGS. 4 and 6.

[035] In some examples, data comprising input to the transmit chain, $y[m]$, and corresponding sensed (i.e., including demodulation) output of the transmit chain, $q[m]$, are collected in a series of iterations, with the parameters $\Theta = \{a_k\}$ being determined from the collected data. In some examples, the collected data sequences $e_{k-1}[m]$, representing the pre-distortion added to the original signal, are obtained through iterations as follows:

- Assume $q_0[m] = y_0[m] + e_0[m]$, where $y_0[m]$ is the original signal sequence without the pre-distortion.
- Iterate the training sequence $y_1[m] = y_0[m] - e_0[m]$, and find $e_1[m] = q_1[m] - y_0[m]$.
- Continue iterating $y_k[m] = y_0[m] - e_{k-1}[m]$, and find $e_k[m] = q_k[m] - y_0[m]$, for $k = 2, 3, \dots$.
- After a final iteration (K), the pre-distorter is configured such that for an input $q_k[m] = y_0[m] + e_k[m]$ the predistorter produces an output $y_K[m] = y_0[m] - e_{K-1}[m]$

[036] In an alternative approach, the nonlinear transformation of $y_0[m]$ to yield $q_0[m]$ is used to characterize the transmit chain (e.g., according to a different parameterization than is used for the pre-distorter). The parameters $\Theta = \{a_k\}$ are then determined to best “invert” the estimated characteristics of the transmit chain.

[037] In some implementations, the parameters Θ are determined based on a predictor, which accepts parameters, for instance, temperature, power supply voltage (Vdd), sampling rate, modulation mode, frequency band, part signature (e.g., obtained by short

in-fab part characterization using a few tones or a special transmit sequences), and part age. Based on these, the predictor unit determines the regime of operation for the compensator and outputs updated coefficients for the compensator and selects parameters of a predetermined set of parameters.

[038] Implementations of the approaches described above may use hardware, software, or a combination of hardware and software. Software may include instructions for a general purpose, a special purpose processor or a heterogeneous processor, with the instructions being stored on a non-transitory machine readable medium and read from the medium for execution by the processor. The instructions may be machine level, or may be represented in programming language form. In some examples, at least some of the transmit chain is implemented in software, and the DPD approach is implemented as further software executed on the sample signal processor or system that implements that part of the transmit chain. In some examples, the software is executed on a processor specifically dedicated to implementation of the DPD.

[039] At least some implementations of the DPD make use of circuitry, which generally includes circuitry for digital signal processing (e.g., arithmetic computation circuitry) which may be dedicated (e.g., as application specific integrated circuits, ASICs, or Field-Programmable Gate Arrays) to particular functions described above and/or may be controlled by software instructions that implement the functions. In some implementations, a computer accessible storage medium includes a database representative of some or all of a DPD 200. Generally speaking, a computer accessible storage medium may include any non-transitory storage media accessible by a computer during use to provide instructions and/or data to the computer. For example, a computer accessible storage medium may include storage media such as magnetic or optical disks and semiconductor memories. Generally, the database representative of the system may be a database or other data structure which can be read by a program and used, directly or indirectly, to fabricate the hardware comprising the system. For example, the database may be a behavioral-level description or register-transfer level (RTL) description of the hardware functionality in a high level design language (HDL) such as Verilog or VHDL. The description may be read by a synthesis tool which may synthesize the description to produce a netlist comprising a list of gates from a synthesis library. The netlist comprises a set of gates which also represent the functionality of the hardware comprising the DPD. The netlist may then be placed and routed to either produce the configuration bitfile for the Field-Programmable Gate Array or produce a data set describing geometric shapes to be applied to masks. The masks may then be used in various semiconductor fabrication

steps to produce a semiconductor circuit or circuits corresponding to the DPD In other examples, Alternatively, the database may itself be the netlist (with or without the synthesis library) or the data set

[040] It is to be understood that the foregoing description is intended to illustrate and not to limit the scope of the invention, which is defined by the scope of the appended claims. Other embodiments are within the scope of the following claims.

What is claimed is:

1. A digital compensator for a signal chain comprising at least one analog amplification element, the digital compensator comprising:
 - an input for receiving a desired signal;
 - an output for providing a compensated signal;
 - a storage for a plurality of coefficients; and
 - a signal processor coupled to the input and to the output for processing a desired signal to produce the compensated signal according to the plurality of coefficients;wherein the signal processor comprises a basis formation stage coupled to a basis combination stage;
 - the basis formation stage includes a plurality of basis formation elements, each configured to produce a basis signal that depends on the desired signal provided to the input;
 - at least some of the basis formation elements each includes a non-linear element configured to produce a non-linear transformation of the desired signal, and a filter configured to produce a time filtering of the non-linear transformation;
 - the basis combination stage is configured to accept the plurality of basis signals from the basis formation elements, and to produce a combined signal from said basis signal according to the plurality of coefficients; and
 - the digital compensator is configured to provide the compensated signal at the output according to the combined signal produced by the basis combination stage.
2. The digital compensator of claim 1 wherein the digital compensator is coupled to a signal chain comprising a transmit chain of a radio frequency communication system.
3. The digital compensator of claim 1 further comprising a linear time invariant filter coupled between the input and the basis formation stage.

4. The digital compensator of claim 3 wherein the filter coupled between the input and the basis formation stage is configured according to characteristics of the signal chain.
5. The digital compensator of claim 1 wherein at least some of the non-linear elements of the basis formation elements each implements a polynomial transformation.
6. The digital compensator of claim 5 wherein a polynomial transformation implemented by at least one of the non-linear elements accepts an input u and produces an output of the form $|u|^k$ or $u|u|^k$ for a positive integer k .
7. The digital compensator of claim 1 wherein at least some of the filters of the basis formation elements each implements linear infinite-impulse-response (IIR) filter.
8. The digital compensator of claim 1 wherein at least some of the basis formation elements each comprises a non-polynomial nonlinear element configured to process the output of the filter and produce an output of the basis formation element that depends on a history of the input of the non-polynomial nonlinear element.
9. The digital compensator of claim 8 wherein at least some of the basis non-polynomial nonlinear elements are normalization elements configured to process the output of the filter and produce an output of the basis formation element that depends on a history of the input of the normalization element.
10. The digital compensator of claim 1 wherein the basis combination stage is configured to implement a balanced polynomial combination of the basis signals.
11. The digital compensator of claim 10 wherein the basis combination stage is configured to accept basis signal values w_1 to w_S , for a positive integer S , and to produce a combined signal that represents

$$\sum_k a_k \left(\left(\prod_i (w_i[n])^{b_{k,i}} \right) \left(\prod_j (w_i^*[n])^{c_{k,j}} \right) \right)$$

where w^* denotes a complex conjugate of w , the terms a_k depend on the coefficients, and integer exponents of the terms satisfy

$$\sum_i b_{k,i} = 1 + \sum_j c_{k,j}.$$

12. The digital compensator of claim 1 further comprising a coefficient interpolator configured to provide values of the coefficients.
13. The digital compensator of claim 12 wherein the coefficient interpolator is configured to access a database to determine the values of the coefficients according to at least one of a part signature and environment variables.
14. The digital compensator of claim 13 wherein the coefficient interpolator is further configured to access the part signature from a storage coupled to or associated with the signal chain, the part signature representing substantially unique characteristics of said signal chain.
15. The digital compensator of claim 14 wherein the part signature substantially includes at least one quantity representing a non-linear characteristic of the signal chain.
16. The digital compensator of claim 13 wherein the coefficient interpolator is further configured to access the environment variables from a storage operationally coupled to the signal chain, the environment variables in operation representing operational and/or environmental characteristics of the operating signal chain.
17. The digital compensator of claim 16 wherein the environment variables include a quantity representing at least one of an operating temperature and a supply voltage.
18. A method for digital compensation of a signal chain comprising at least one analog amplification element, the method comprising:
 - receiving a desired signal;

processing the desired signal to produce the compensated signal according to a plurality of coefficients; and

providing the compensated signal to the signal chain;

wherein processing the desired signal comprises

processing a signal that depends on the desired signal in a basis combination stage, including producing a plurality of basis signals, each depending on the desired signal, wherein producing each basis signal of at least some of the basis signals includes performing a non-linear transformation of the desired signal and time filtering the non-linear transformation of the desired signal, combining the plurality of basis signals according to the plurality of coefficients to produce a combined signal, and determining the compensated signal according to the combined signal.

19. The method for digital compensation of claim 18 wherein providing the compensated signal to the signal chain comprises providing said compensated signal to a transmit chain of a radio frequency communication system.

20. The method for digital compensation of claim 18 further comprising applying a linear time invariant filter to the desired input signal prior to processing in the basis formation stage.

21. The method for digital compensation of claim 20 further comprising configuring the linear time invariant filter according to characteristics of the signal chain.

22. The method for digital compensation of claim 18 wherein performing a non-linear transformation of the desired signal comprises applying a polynomial transformation.

23. The method for digital compensation of claim 22 wherein the polynomial transformation includes accepting an input u and producing an output of the form $|u|^k$ or $u|u|^k$ for a positive integer k .

24. The method for digital compensation of claim 18 wherein time-filtering in the basis combination stage includes a linear infinite-impulse-response (IIR) filtering.

25. The method for digital compensation of claim 18 wherein performing a non-linear transformation of the desired signal comprises applying a non-polynomial nonlinear transformation and processing an output of the filter to depend on a history of an input of the non-polynomial nonlinear transformation.

26. The method for digital compensation of claim 25 wherein at least some of the non-polynomial nonlinear transformations include normalization configured to process the output of the filter and produce an output that depends on a history of the input of the normalization.

27. The method for digital compensation of claim 18 wherein the basis combination stage implements a balanced polynomial combination of the basis signals.

28. The method for digital compensation of claim 27 wherein the basis combination stage accepts basis signal values w_1 to w_S , for a positive integer S , and produces a combined signal that represents

$$\sum_k a_k \left(\left(\prod_i (w_i[n])^{b_{k,i}} \right) \left(\prod_j (w_i^*[n])^{c_{k,j}} \right) \right)$$

where w^* denotes a complex conjugate of w , the terms a_k depend on the coefficients, and integer exponents of the terms satisfy

$$\sum_i b_{k,i} = 1 + \sum_j c_{k,j}.$$

29. The method for digital compensation of claim 18 further comprising applying a coefficient interpolator to provide values of the coefficients.

30. The method for digital compensation of claim 29 wherein the coefficient interpolator accesses a database to determine the values of the coefficients according to at least one of a part signature and environment variables.

31. The method for digital compensation of claim 30 wherein the coefficient interpolator accesses the part signature from a storage coupled to or associated with the signal chain, the part signature representing substantially unique characteristics of said signal chain.

32. The method for digital compensation of claim 31 wherein the part signature substantially includes at least one quantity representing a non-linear characteristic of the signal chain.

33. The method for digital compensation of claim 30 wherein the coefficient interpolator accesses the environment variables from a storage operationally coupled to the signal chain, the environment variables in operation representing operational and/or environmental characteristics of the operating signal chain.

34. The method for digital compensation of claim 33 wherein the environment variables include a quantity representing at least one of an operating temperature and a supply voltage.

35. Software comprising a non-transitory machine-readable medium having instructions stored thereon, execution of the instructions causing a data processing system to:

receive a desired signal;

process the desired signal to produce the compensated signal according to a plurality of coefficients; and

provide the compensated signal to the signal chain;

wherein processing the desired signal comprises

processing a signal that depends on the desired signal in a basis combination stage, including producing a plurality of basis signals, each depending on the desired signal, wherein producing each basis signal of at least some of the basis signals includes performing a non-linear transformation of the desired signal and time filtering the non-linear transformation of the desired signal,

combining the plurality of basis signals according to the plurality of coefficients to produce a combined signal, and
determining the compensated signal according to the combined signal.

36. A design structure encoded on a non-transitory machine-readable medium, said design structure comprising elements, when processed in a computer-aided design system, generate a machine-executable representation of a digital compensator, wherein said digital compensator comprises:

an input for receiving a desired signal;

an output for providing a compensated signal;

a storage for a plurality of coefficients; and

a signal processor coupled to the input and to the output for processing a desired signal to produce the compensated signal according to the plurality of coefficients;

wherein the signal processor comprises a basis formation stage coupled to a basis combination stage;

the basis formation stage includes a plurality of basis formation elements, each configured to produce a basis signal that depends on the desired signal provided to the input;

at least some of the basis formation elements each includes a non-linear element configured to produce a non-linear transformation of the desired signal, and a filter configured to produce a time filtering of the non-linear transformation;

the basis combination stage is configured to accept the plurality of basis signals from the basis formation elements, and to produce a combined signal from said basis signal according to the plurality of coefficients; and

the digital compensator is configured to provide the compensated signal at the output according to the combined signal produced by the basis combination stage.

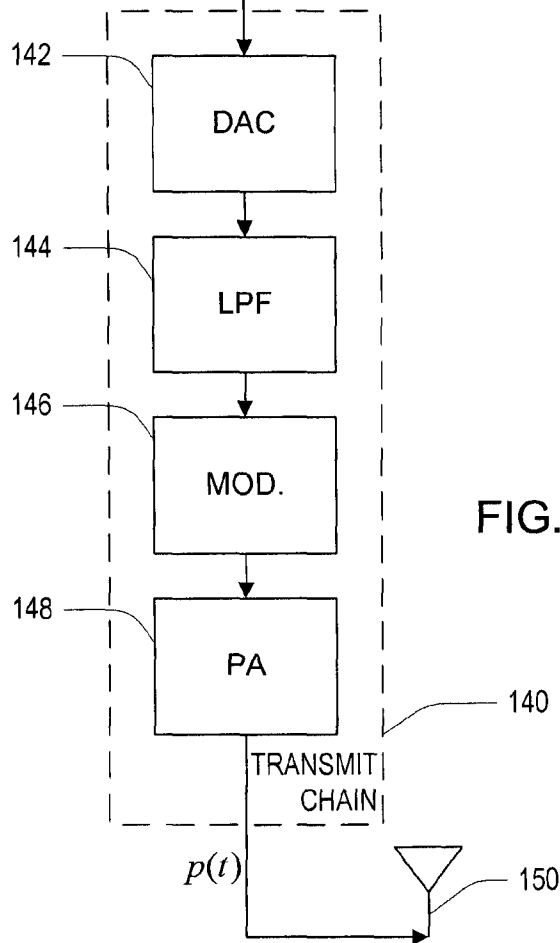
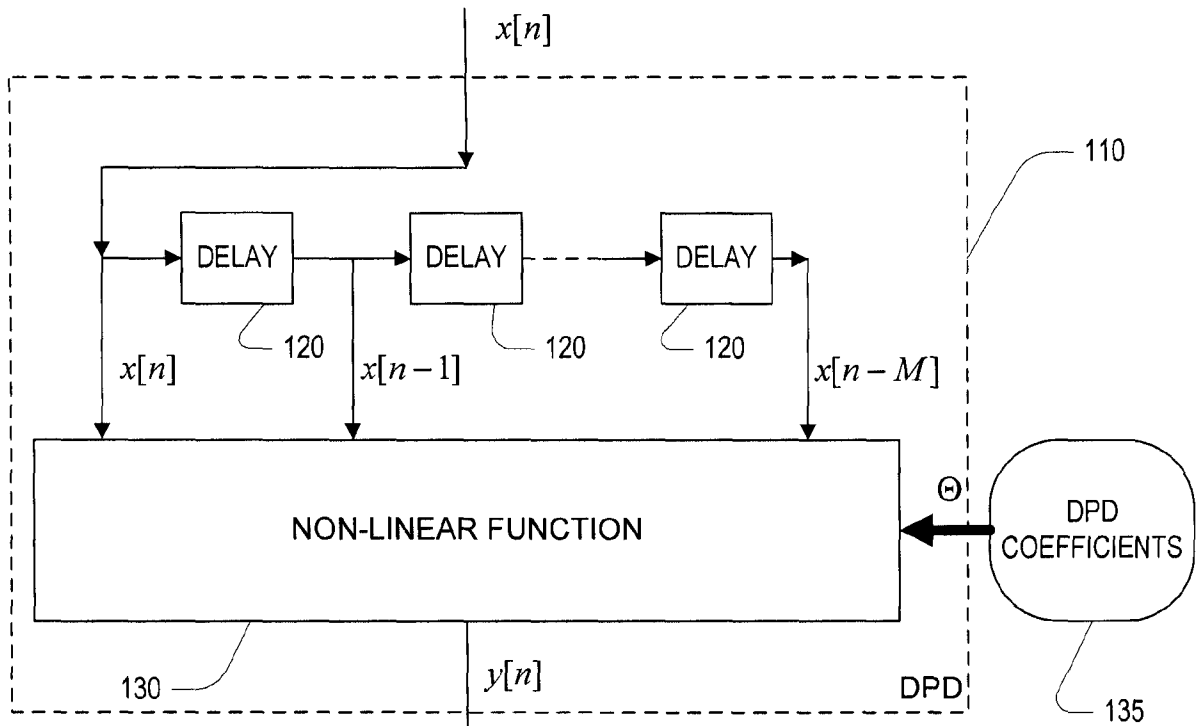

FIG. 1 (PRIOR ART)

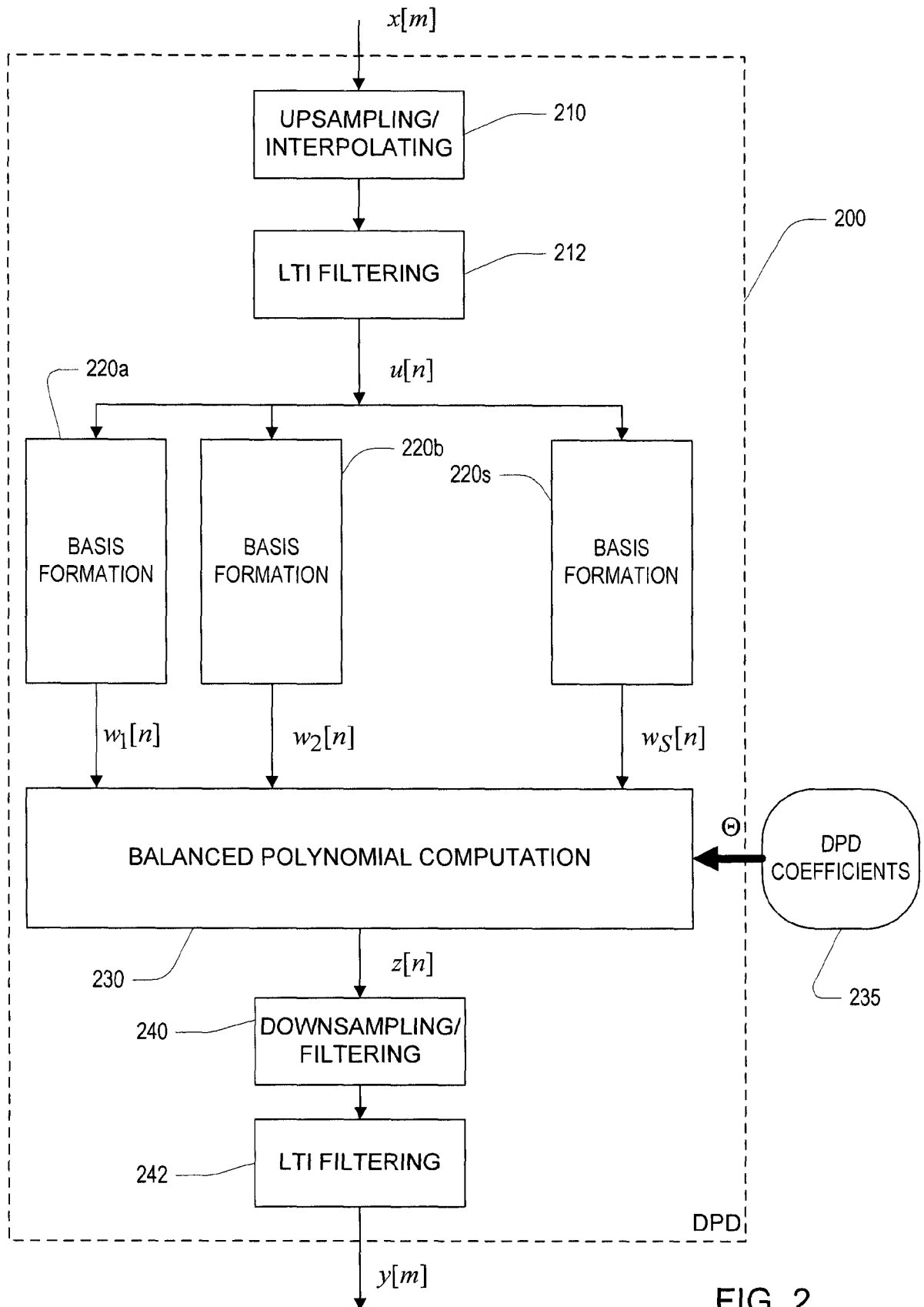

FIG. 2

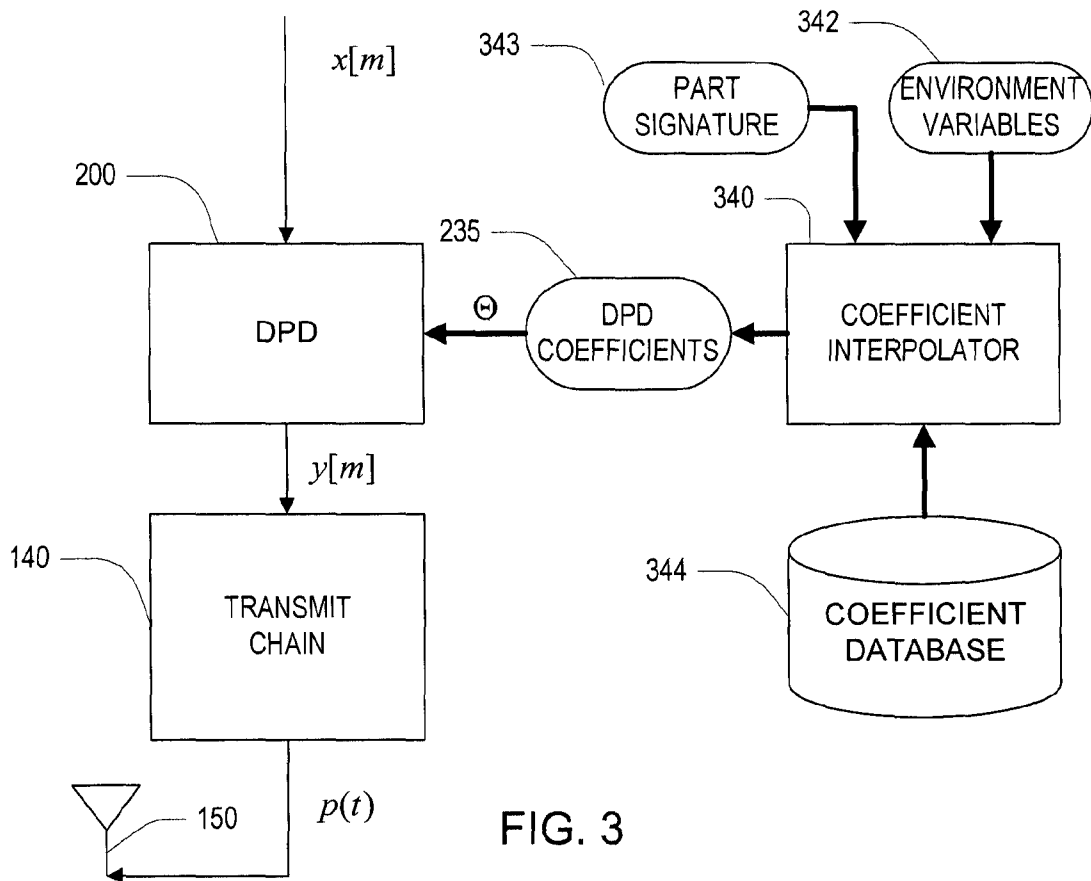

FIG. 3

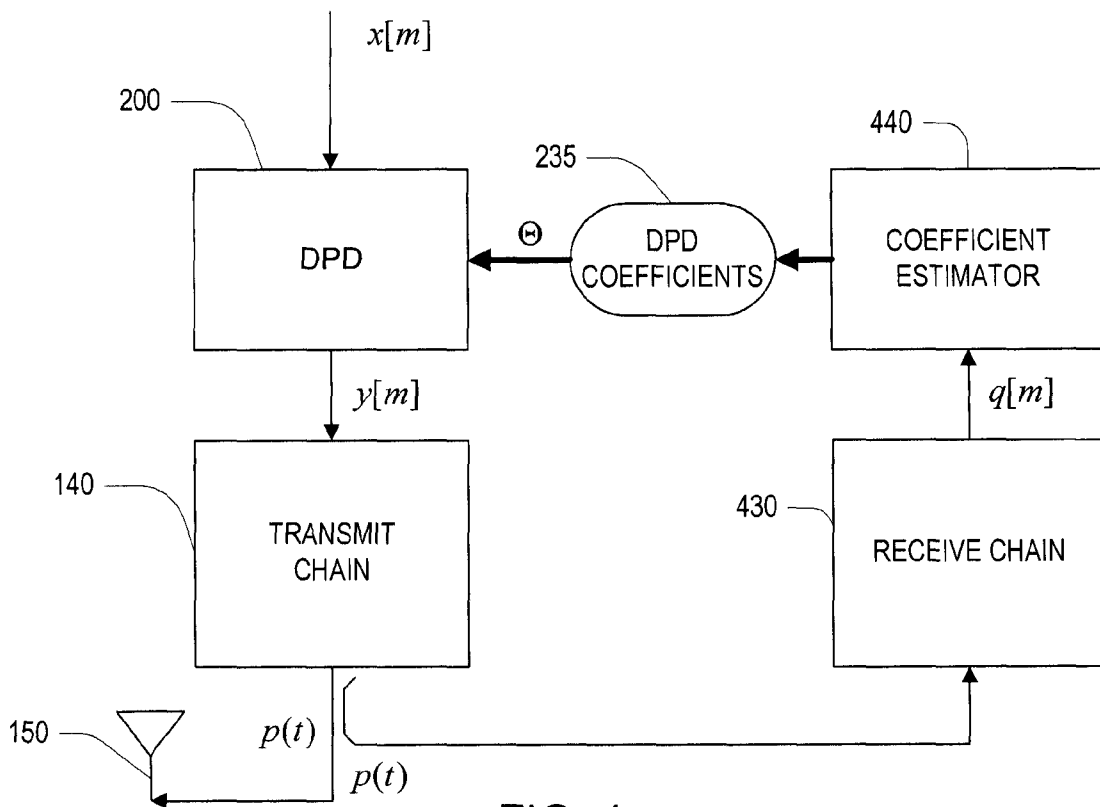

FIG. 4

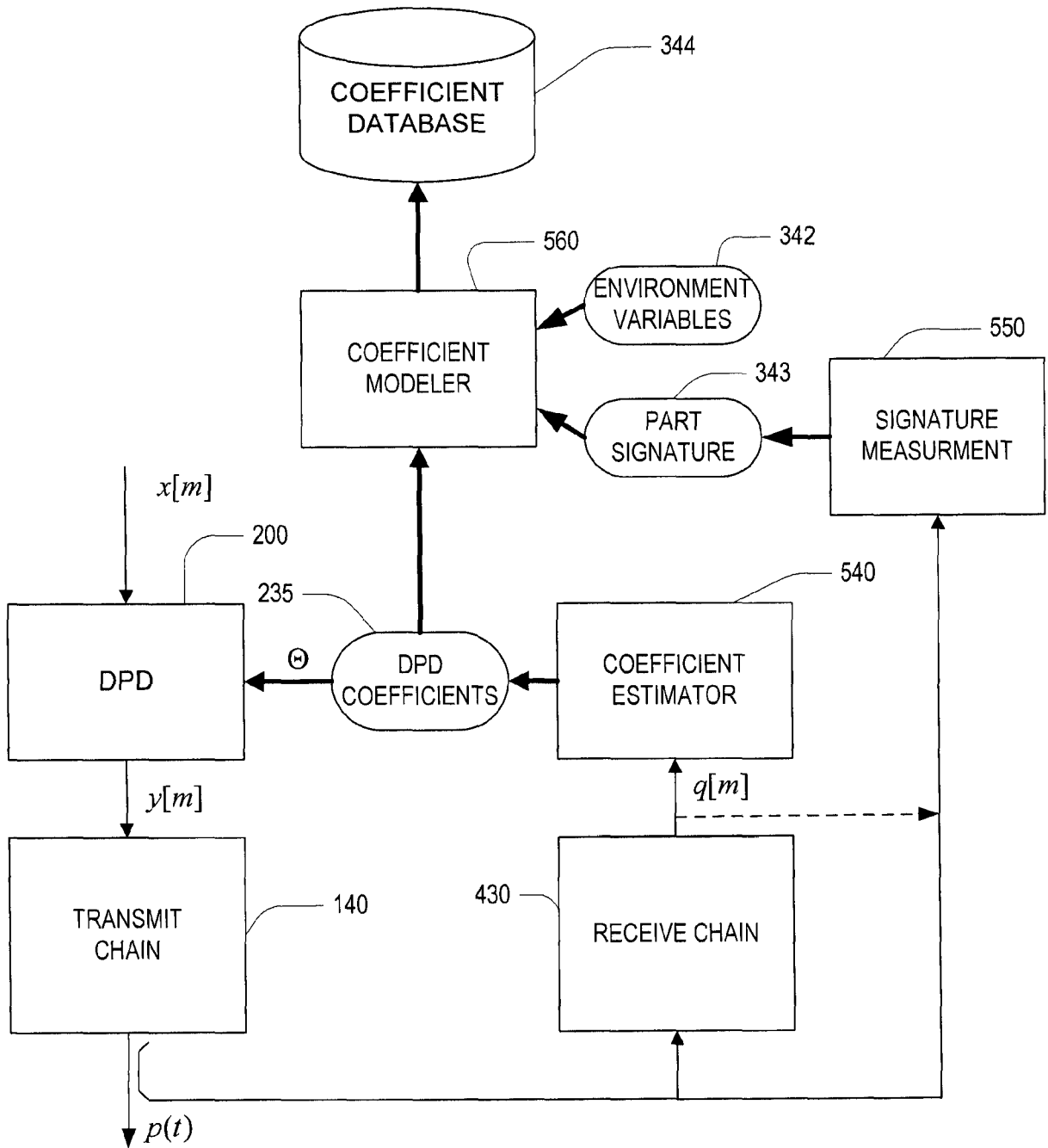

FIG. 5

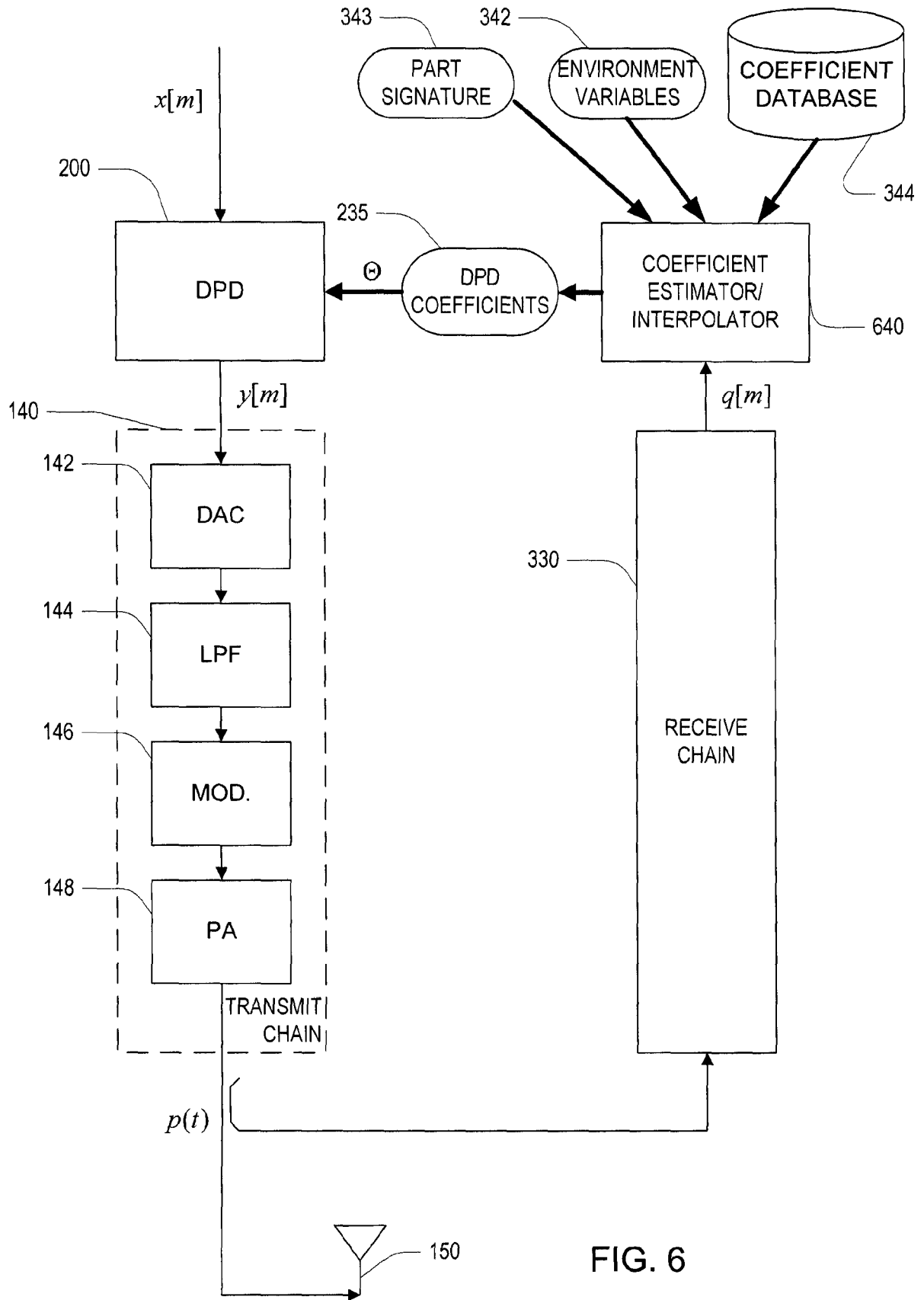

FIG. 6

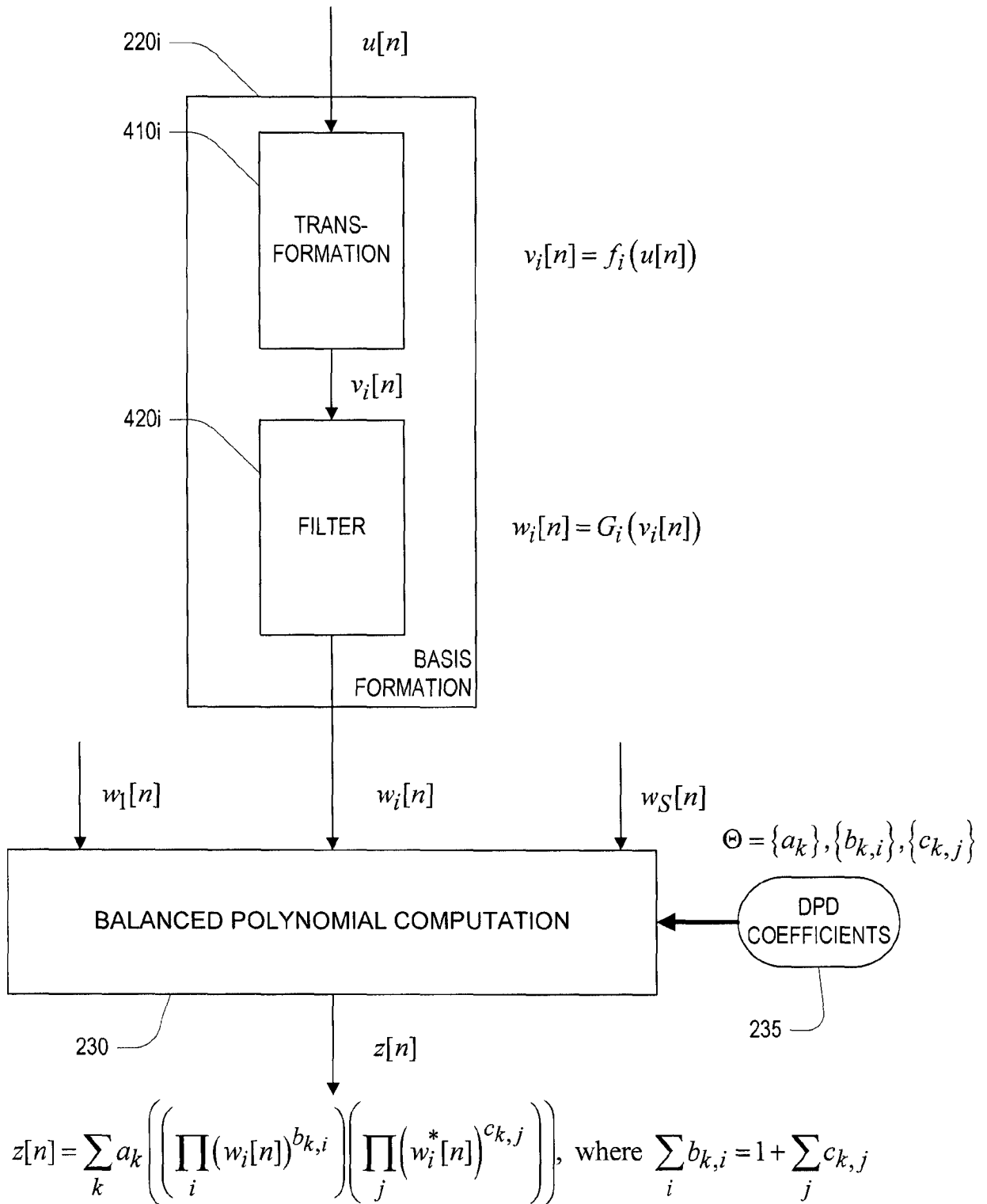

FIG. 7

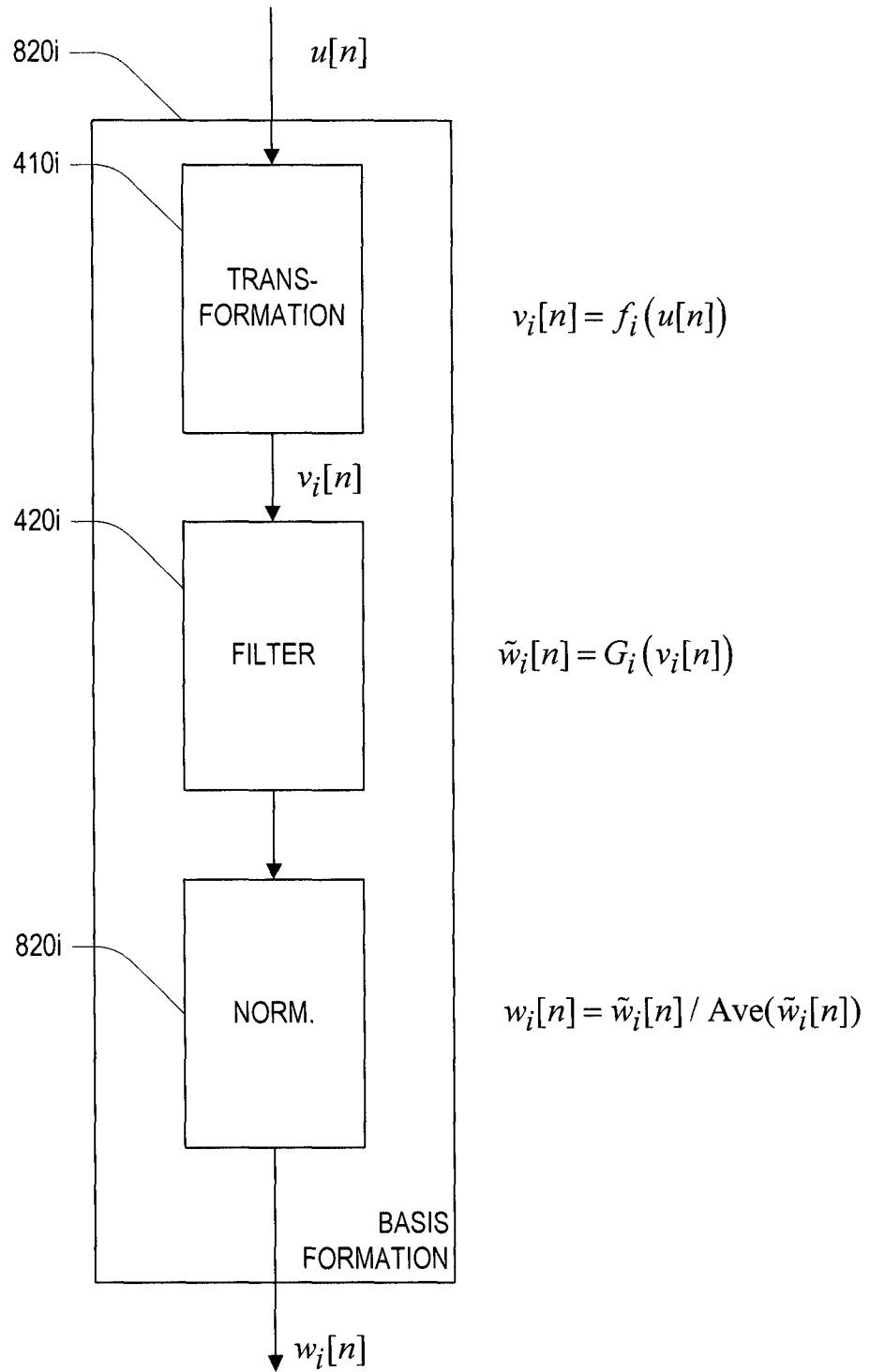

FIG. 8

INTERNATIONAL SEARCH REPORT

International application No
PCT/US2016/064127

A. CLASSIFICATION OF SUBJECT MATTER
INV. H03F1/32
ADD.
According to International Patent Classification (IPC) or to both national classification and IPC

B. FIELDS SEARCHED
Minimum documentation searched (classification system followed by classification symbols)
H03F

Documentation searched other than minimum documentation to the extent that such documents are included in the fields searched

Electronic data base consulted during the international search (name of data base and, where practicable, search terms used)
EPO-Internal, WPI Data

C. DOCUMENTS CONSIDERED TO BE RELEVANT

Category*	Citation of document, with indication, where appropriate, of the relevant passages	Relevant to claim No.
X	US 2005/001684 A1 (BRAITHWAITE RICHARD NEIL [US]) 6 January 2005 (2005-01-06) paragraph [0070]; figures 1,5,8 paragraph [0077] - paragraph [0087] ----- -/--	1-6,8, 10,12, 18-23, 25,27, 29,35,36

Further documents are listed in the continuation of Box C.

See patent family annex.

* Special categories of cited documents :

- "A" document defining the general state of the art which is not considered to be of particular relevance
- "E" earlier application or patent but published on or after the international filing date
- "L" document which may throw doubts on priority claim(s) or which is cited to establish the publication date of another citation or other special reason (as specified)
- "O" document referring to an oral disclosure, use, exhibition or other means
- "P" document published prior to the international filing date but later than the priority date claimed

- "T" later document published after the international filing date or priority date and not in conflict with the application but cited to understand the principle or theory underlying the invention
- "X" document of particular relevance; the claimed invention cannot be considered novel or cannot be considered to involve an inventive step when the document is taken alone
- "Y" document of particular relevance; the claimed invention cannot be considered to involve an inventive step when the document is combined with one or more other such documents, such combination being obvious to a person skilled in the art
- "&" document member of the same patent family

Date of the actual completion of the international search 2 March 2017	Date of mailing of the international search report 10/03/2017
---	--

Name and mailing address of the ISA/ European Patent Office, P.B. 5818 Patentlaan 2 NL - 2280 HV Rijswijk Tel. (+31-70) 340-2040, Fax: (+31-70) 340-3016	Authorized officer Kurzbauer, Werner
--	---

INTERNATIONAL SEARCH REPORT

International application No

PCT/US2016/064127

C(Continuation). DOCUMENTS CONSIDERED TO BE RELEVANT		
Category*	Citation of document, with indication, where appropriate, of the relevant passages	Relevant to claim No.
X	OSAMU MUTA ET AL: "Adaptive predistortion linearization based on orthogonal polynomial expansion for nonlinear power amplifiers in OFDM systems", COMMUNICATIONS AND SIGNAL PROCESSING (ICCSP), 2011 INTERNATIONAL CONFERENCE ON, IEEE, 10 February 2011 (2011-02-10), pages 512-516, XP031932638, DOI: 10.1109/ICCSP.2011.5739374 ISBN: 978-1-4244-9798-0 page 2, right-hand column - page 3, left-hand column; figures 1,2 -----	1,2,5-8, 10,12, 18,19, 22-25, 27,29, 35,36
X	EP 1 560 329 A1 (NTT DOCOMO INC [JP]) 3 August 2005 (2005-08-03) paragraphs [0035], [0036], [0054]; figures 9,19 -----	1-6,10, 18-23, 27,35,36
X	US 2011/163806 A1 (HONGO NAOKI [JP]) 7 July 2011 (2011-07-07) paragraph [0084] - paragraph [0087]; figure 8 -----	1,2,5-8, 10,12, 18,19, 22-25, 27,29, 35,36
A	US 8 731 105 B2 (BAI CHUNLONG [CA]) 20 May 2014 (2014-05-20) the whole document -----	1-36
A	WO 2012/154430 A1 (ANDREW LLC [US]; CHANDRASEKARAN RAJIV [US]) 15 November 2012 (2012-11-15) the whole document -----	1-36
A	US 2006/276147 A1 (SUZUKI YASUNORI [JP] ET AL) 7 December 2006 (2006-12-07) figures 1,8,9 -----	1-36
A	US 2012/119810 A1 (BAI CHUNLONG [CA]) 17 May 2012 (2012-05-17) the whole document -----	1-36
A	& US 8 368 466 B2 (BAI CHUNLONG [CA]) 5 February 2013 (2013-02-05) the whole document -----	1-36
A	US 2008/057882 A1 (SINGERL PETER [AT] ET AL) 6 March 2008 (2008-03-06) the whole document -----	1-36

INTERNATIONAL SEARCH REPORT

Information on patent family members

International application No

PCT/US2016/064127

Patent document cited in search report	Publication date	Patent family member(s)	Publication date	
US 2005001684	A1	06-01-2005	CN 1833418 A	13-09-2006
			EP 1645094 A2	12-04-2006
			KR 20060026480 A	23-03-2006
			US 2005001684 A1	06-01-2005
			WO 2005008883 A2	27-01-2005

EP 1560329	A1	03-08-2005	CN 1649260 A	03-08-2005
			EP 1560329 A1	03-08-2005
			ES 2361998 T3	27-06-2011
			JP 4255849 B2	15-04-2009
			JP 2005217714 A	11-08-2005
			KR 20050077781 A	03-08-2005
			US 2005180527 A1	18-08-2005

US 2011163806	A1	07-07-2011	CN 102106079 A	22-06-2011
			JP 5205182 B2	05-06-2013
			JP 2010068142 A	25-03-2010
			US 2011163806 A1	07-07-2011
			WO 2010029690 A1	18-03-2010

US 8731105	B2	20-05-2014	NONE	

WO 2012154430	A1	15-11-2012	CN 103620953 A	05-03-2014
			US 2012286865 A1	15-11-2012
			WO 2012154430 A1	15-11-2012

US 2006276147	A1	07-12-2006	CN 1877987 A	13-12-2006
			DE 602006000622 T2	26-03-2009
			EP 1732208 A1	13-12-2006
			JP 4344367 B2	14-10-2009
			JP 2007020157 A	25-01-2007
			KR 20060127785 A	13-12-2006
			US 2006276147 A1	07-12-2006

US 2012119810	A1	17-05-2012	CA 2815438 A1	24-05-2012
			CN 103201949 A	10-07-2013
			EP 2641327 A1	25-09-2013
			JP 5753272 B2	22-07-2015
			JP 2013542696 A	21-11-2013
			US 2012119810 A1	17-05-2012
			WO 2012066382 A1	24-05-2012

US 2008057882	A1	06-03-2008	NONE	
