

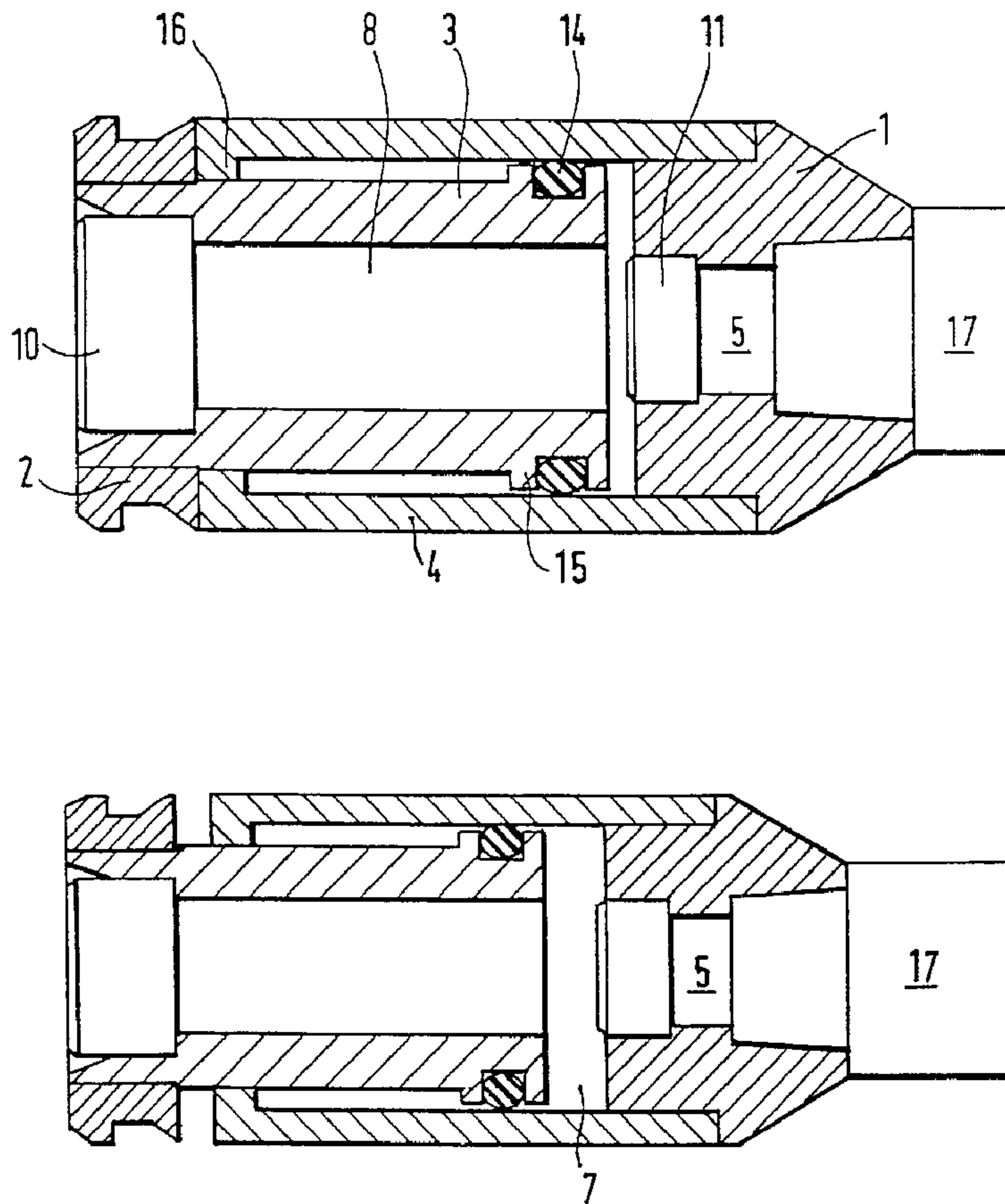

(86) Date de dépôt PCT/PCT Filing Date: 2000/08/15
 (87) Date publication PCT/PCT Publication Date: 2001/03/08
 (45) Date de délivrance/Issue Date: 2008/12/09
 (85) Entrée phase nationale/National Entry: 2002/02/20
 (86) N° demande PCT/PCT Application No.: GB 2000/003128
 (87) N° publication PCT/PCT Publication No.: 2001/016550
 (30) Priorité/Priority: 1999/08/27 (GB9920205.3)

(51) Cl.Int./Int.Cl. *F42B 5/10* (2006.01),
F42B 5/02 (2006.01), *F42B 8/02* (2006.01)
 (72) Inventeur/Inventor:
SAXBY, MICHAEL ERNEST, GB
 (73) Propriétaire/Owner:
UTM IP LIMITED, GB
 (74) Agent: MARKS & CLERK

(54) Titre : CARTOUCHE D'ENTRAÎNEMENT POUR PISTOLET AUTOMATIQUE
 (54) Title: TRAINING CARTRIDGE FOR A SELF LOADING GUN



(57) Abrégé/Abstract:

A cartridge for use in non-lethal applications comprises an anterior portion (1) and a posterior portion (2). The posterior portion comprises a recycling mechanism (3), which is initiated on activation of a primer (10) and the anterior portion has a nose portion



(57) **Abrégé(suite)/Abstract(continued):**

suitable for receiving a projectile (17). A source of energetic material (11) is located in the anterior portion, this being initiatable by a reaction produced on activation of the primer to cause propulsion of the projectile from the cartridge.

(12) INTERNATIONAL APPLICATION PUBLISHED UNDER THE PATENT COOPERATION TREATY (PCT)

(19) World Intellectual Property Organization
International Bureau



(43) International Publication Date
8 March 2001 (08.03.2001)

PCT

(10) International Publication Number
WO 01/16550 A1

(51) International Patent Classification⁷: F42B 5/10, 8/02

Ernest [GB/GB]; Summerleas, Peartree Lane, Bexhill on Sea, East Sussex TN39 5JN (GB).

(21) International Application Number: PCT/GB00/03128

(74) Agents: MADDISON, Victoria, Jayne et al.; Fry Heath & Spence, The Old College, 53 High Street, Horley, Surrey RH6 7BN (GB).

(22) International Filing Date: 15 August 2000 (15.08.2000)

(25) Filing Language: English

(81) Designated States (*national*): AE, AG, AL, AM, AT, AU, AZ, BA, BB, BG, BR, BY, BZ, CA, CH, CN, CR, CU, CZ, DE, DK, DM, DZ, EE, ES, FI, GB, GD, GE, GH, GM, HR, HU, ID, IL, IN, IS, JP, KE, KG, KP, KR, KZ, LC, LK, LR, LS, LT, LU, LV, MA, MD, MG, MK, MN, MW, MX, MZ, NO, NZ, PL, PT, RO, RU, SD, SE, SG, SI, SK, SL, TJ, TM, TR, TT, TZ, UA, UG, US, UZ, VN, YU, ZA, ZW.

(26) Publication Language: English

(30) Priority Data:
9920205.3 27 August 1999 (27.08.1999) GB

(71) Applicant (*for all designated States except US*): LAMBETH PROPERTIES LIMITED [BS/BS]; Charlotte House, Charlotte Street, P.O. Box B-341, Nassau (BS).

(84) Designated States (*regional*): ARIPO patent (GH, GM, KE, LS, MW, MZ, SD, SL, SZ, TZ, UG, ZW), Eurasian patent (AM, AZ, BY, KG, KZ, MD, RU, TJ, TM), European patent (AT, BE, CH, CY, DE, DK, ES, FI, FR, GB, GR, IE,

(72) Inventor; and
(75) Inventor/Applicant (*for US only*): SAXBY, Michael,

[Continued on next page]

(54) Title: TRAINING CARTRIDGE FOR A SELF LOADING GUN

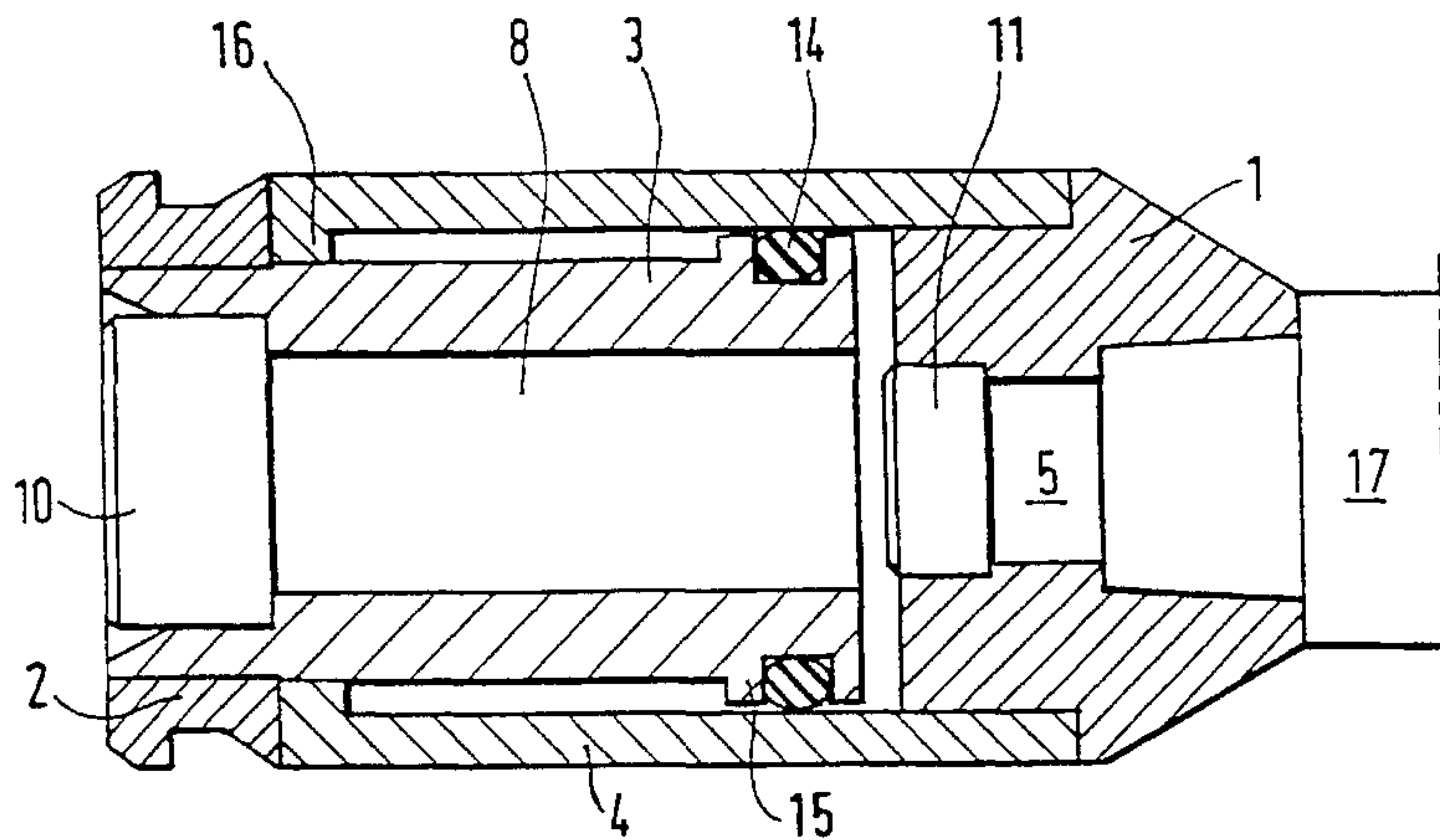

(57) Abstract: A cartridge for use in non-lethal applications comprises an anterior portion (1) and a posterior portion (2). The posterior portion comprises a recycling mechanism (3), which is initiated on activation of a primer (10) and the anterior portion has a nose portion suitable for receiving a projectile (17). A source of energetic material (11) is located in the anterior portion, this being initiatable by a reaction produced on activation of the primer to cause propulsion of the projectile from the cartridge.

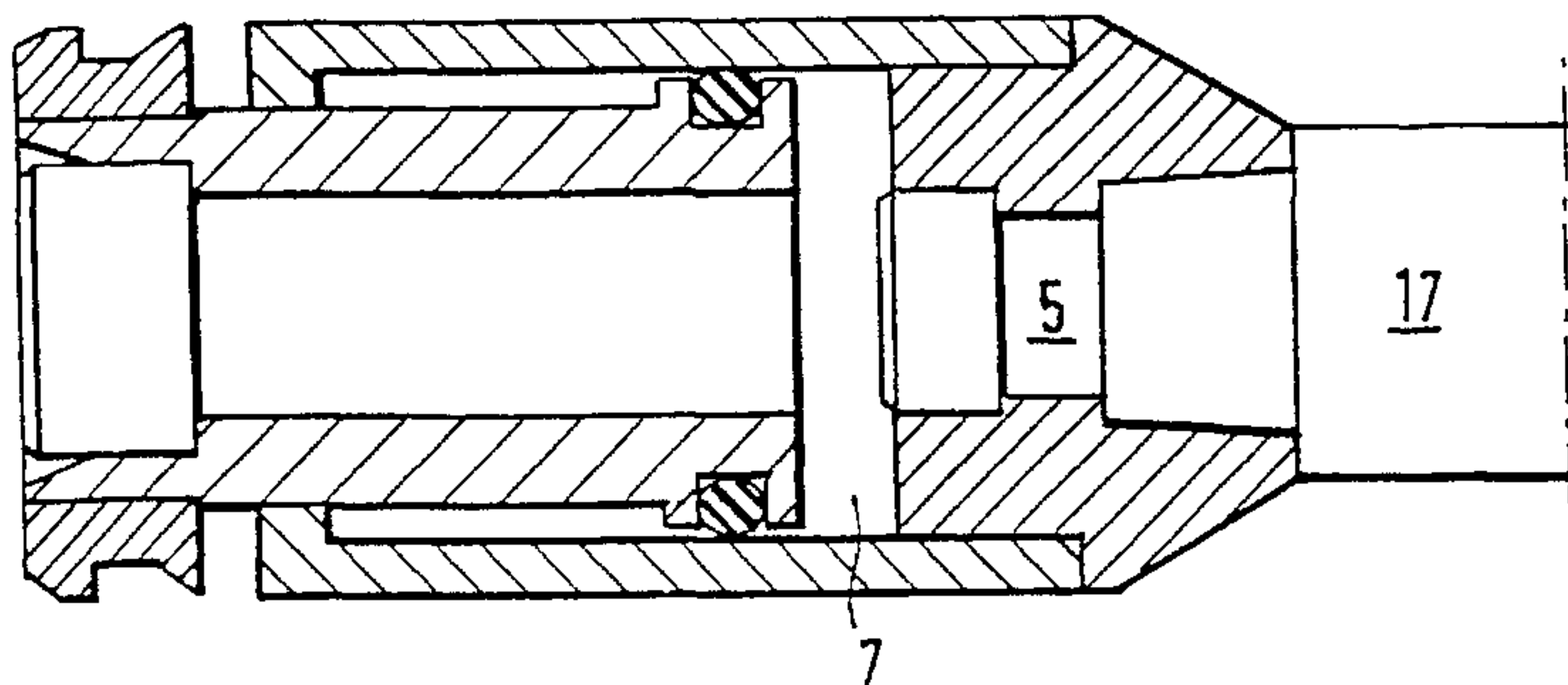

WO 01/16550 A1

WO 01/16550 A1



IT, LU, MC, NL, PT, SE), OAPI patent (BF, BJ, CF, CG, CI, CM, GA, GN, GW, ML, MR, NE, SN, TD, TG).

For two-letter codes and other abbreviations, refer to the "Guidance Notes on Codes and Abbreviations" appearing at the beginning of each regular issue of the PCT Gazette.

Published:

— *With international search report.*

TRAINING CARTRIDGE FOR A SELF LOADING GUN

5

The present invention relates to ammunition, particularly non-lethal ammunition intended for use in training or war games. More especially the invention relates to a telescopic cartridge in which rearwards movement of a portion of the cartridge is used to initiate the recycling of an automatic or semi-automatic firearm.

10

One form of cartridge of the above type is shown in Figure 1 and is the subject of co-pending GB Patent Application 9819928.4.

15

Cartridges of the type described above are suitable for use both in the firing of blanks and projectiles for the purposes of simulating warfare. Simulation may be for training purposes or for recreation. Whilst this cartridge has overcome many of the problems suffered by its predecessors, in providing a feel similar to that of a lethal loaded cartridge, it has some drawbacks in the accuracy and repeatability of its performance.

20

25

A disadvantage of the previously known cartridges is due to their reliance on a single source of high pressure gas which performs both the objectives of propelling the projectile from the gun and cycling the guns reloading mechanism. The dividing of the gas to perform these two objectives cannot be carried out precisely due to engineering mechanical tolerances associated with the cartridge components. Whilst the gas provided by a primer is generally consistent due to sophisticated manufacturing techniques, for some types of cartridge a single primer does not provide sufficient energy to perform these two objectives safely and reliably.

30

It is an object of the present invention to provide a cartridge for use with firearms in warfare training and simulation exercises which can go some way to

alleviating these disadvantages.

In accordance with the present invention there is provided a cartridge for use in non-lethal applications comprising an anterior portion and a posterior portion, the posterior portion comprising a recycling mechanism, the recycling being initiated on
5 activation of a primer and the anterior portion being provided with a nose portion which is suitable for receiving a projectile, characterised by a source of energetic material being initiatable by a reaction produced on activation of the primer to cause propulsion of the projectile from the cartridge.

10 The energetic material source provided toward the anterior end of the cartridge can conveniently be initiated by the shock or pressure wave associated with propellant gases used to propel a moveable member against the breech block. The energetic material can be chosen according to its pyrotechnic qualities to additionally
15 provide a noise reminiscent of any chosen lethal ammunition. Optionally, the energetic material may also produce a visual effect such as a flash of colour to simulate a lethal projectile exiting the firearm. Preferably, the energetic material is a non-toxic primer, this renders the cartridge more environmentally friendly and safer to use.

20 Thus the present invention provides two independent energetic sources, one to initiate the cycling of the reload mechanism and the other to propel a projectile from the casing. By separating the energetic sources in this manner a more predictable response can be produced on repeated firings of the firearm using a
25 cartridge according to the present invention. The feedback to the user on firing such a cartridge is more realistic of a typical feedback response from a lethal cartridge.

A typical cartridge according to the present invention will comprise a
30 posterior portion which has a moveable member which is slideable rearwardly towards a breech block, the anterior portion having a gas passage therethrough; an expansion chamber being provided between the moveable member and the anterior

portion, and gas generating means for providing gas within the cartridge, the gas generating means being initiatable on firing of the firearm to propel the moveable member in a rearward direction so as to recycle the firearm. The energetic material is positioned forward of the gas passage and may be initiated by any suitable reaction
5 caused on initiation of the primer. For example, the shock or pressure wave generated on activation of the primer may be sufficient to initiate the energetic material, or alternatively, activation of the primer may activate a secondary mechanical or electrical device which serves to initiate the energetic material.

10 The energetic material can be chosen to suit the size, mass and desired velocity of the projectile on firing. Different requirements may be met using different energetic materials or different quantities of the same energetic material.

15 In certain embodiments, the moveable member may be provided in the form of a piston or cylinder slideably engaged respectively with a cylinder or a piston. Preferably in these embodiments, the moveable member is in the form of a piston slideably engaged respectively with a cylinder.

20 The energetic material may be positioned either in association with the moveable member or separately in the anterior portion of the casing.

In order to further explain the invention, a description of one embodiment of the invention is now given with reference to the Figures in which;

25 Figure 1 shows a prior art cartridge of the type described in GB Application No. 9819928.4;

30 Figure 2 shows one embodiment of the invention having a nose portion at the anterior end, the nose portion being suitable for receiving a projectile, the projectile being propellable on initiation of the energetic material.

In Figure 1, a gun cartridge 30 comprises a cylindrical cartridge case 32 with an in-turned flange 34 at the rearward end. The forward end casing comprises a nose portion 36, which in this embodiment is in the form of a plug, from which sleeve 44 extends in a rearwards direction. The plug 36 has an axial bore or gas passage 38, the axial bore being stepped so that the larger diameter forward section of the bore 40 forms a recessed seat in which is received the trailing end of a bullet 42.

The inner surface of the sleeve and the rearward surface 46 of the plug define a piston chamber 48. A piston 50 is slideably contained within the piston chamber 48 and has a pair of outwardly extending flanges 52 at its forward end. Nested between the flanges 52 and surrounding piston is an O-ring 54 to provide a seal between the forward end of the piston and the inner surface of the casing.

A pyrotechnic composition 56 is housed at the rearward end of the piston 50. Extending from the pyrotechnic composition to the forward end of the piston is a first gas expansion chamber 58. At the head of the gas expansion chamber 58, gas channels 62 allow the flow of propellant gas from the first expansion chamber 58 into the second expansion chamber 48a (which corresponds to the expansion chamber defined in the claims appended hereto), which is defined by the space between the piston head and the rearward surface 46 of the plug.

A spigot 64 extends from the forward end of the piston and is slideably contained within the axial bore or gas passage 38 of the plug. The spigot has an axial gas passage 66 therethrough which provides a gas flow path from the gas first expansion chamber 58 via laterally extending passage 66a to outlets 68. Outlets 68 open out into the larger diameter forward section 40 of the bore 38 immediately behind the rear edge 42c of the hollow cylindrical skirt portion of the bullet 42. The annular space 40a formed between the rear edge 42c of the bullet, the outer wall of the spigot and the axially facing surface 36a of the plug functions as a third expansion chamber.

In operation, the pyrotechnic composition is activated by the firearm's firing

pin P and the propellant gas produced expands into the first gas expansion chamber 58 and through the passage 66 in the spigot 64 to the third expansion chamber 40a, thereby discharging the bullet 42 from its seat. At substantially the same instant, gas flows through the gas channels 62 between the first gas expansion chamber 58 and the second expansion chamber 48a at the front of the piston. The pressurised gas forces the piston to move rearwardly relative to the outer casing 32, thereby urging the spigot 64 in a rearwards direction against the breech block B. As a result of the rearward displacement of the piston and spigot, the outlets 68 are substantially sealed by the inner surface of the axial bore 38 so preventing the flow of gas to the forward section of the bore 40 (see Figure 2).

Consequently, the full force of the remaining propellant gas is directed through the gas channels 62 as the piston shoots backwards against the breech block to recycle the firearm. The flange 52 on the forward end of the piston engages with the flange 34 on the rearward end of the casing 32, therefore preventing further rearward motion of the piston and expulsion of the piston from the cartridge casing.

In Figure 2 a cartridge comprises an anterior portion 1 and a posterior portion 2 the posterior portion comprising a piston 3 slideable in a cylinder 4 extending rearwardly from the anterior portion 1. The anterior portion 1 is provided with a gas passage 5 which communicates with an expansion chamber 7. The piston 3 is provided with a hollow interior 8 which connects with expansion chamber 7.

Disposed toward the posterior end of the piston 3 is a first primer 10 and in the anterior portion there is a second primer 11.

A rubber sealing ring 14 is provided between the piston 3 and cylinder 4 to prevent passage of gas to the posterior portion 2. Adjacent the rubber sealing ring 14, the piston is provided with a rim of extended circumference 15, which, when the piston is allowed to extend from the cylinder, encounters a flange 16 provided on the inner circumference of the cylinder 4 to the posterior end of the cylinder 4.

In the embodiment of Figure 2 the first primer 10 is initiated by, for example,

6

a firing pin to produce a volume of gas. The gas travels along the hollow interior 8 and into expansion chamber 7. Expansion of the gas causes the piston 3 to slide rearwardly within cylinder 4 towards a breech block (not shown). The piston 3 is prevented from exiting cylinder 4 by the flange and rim (16, 15) provided respectively on the inner circumference of the cylinder 4 and piston 3. The shock/pressure wave created on ignition of first primer 10 initiates a second energetic response on second primer 11 located in the anterior portion 1 of the cartridge. The anterior portion 1 is provided with an internal profile suitable for receiving a projectile 17. The energetic reaction produced in primer 11 propels the projectile 17 from the cartridge at high speed to create the impression of a live bullet being fired. Thus it can be seen that recycling and firing of the projectile are controlled independently by two separate energetic reactions.

It is to be understood that the foregoing is merely exemplary of two embodiments of the invention and that modifications can be made thereto without departing from the scope of the invention.

The embodiments of the invention in which an exclusive property or privilege is claimed are defined as follows:

1. A cartridge for use in non-lethal applications comprising an anterior portion and a posterior portion, the posterior portion comprising a recycling mechanism, the recycling mechanism being initiated on activation of a primer and the anterior portion being provided with a nose portion which is suitable for receiving a projectile, characterised by a source of energetic material located in the anterior portion, the energetic material being initiatable by a reaction produced on activation of the primer to cause propulsion of the projectile from the cartridge.
2. A cartridge for use in non-lethal applications as claimed in claim 1, wherein the posterior portion comprises a moveable member which is slideable rearwardly towards a breech block, the anterior portion having a gas passage therethrough; an expansion chamber being provided between the moveable member and the anterior portion gas generating means for providing gas within the cartridge, the gas generating means being initiatable by the primer on firing of the firearm to propel the moveable member in a rearward direction against the breech block so as to recycle the firearm, the source of energetic material positioned forward of the gas channel.
3. A cartridge as claimed in claim 2, wherein the moveable member is in the form of a piston or cylinder slideably engaged respectively with a cylinder or a piston.
4. A cartridge as claimed in claim 3, wherein the moveable member is in the form of a piston slideably engaged respectively with a cylinder.
5. A cartridge as claimed in any one of claims 2 to 4, wherein the energetic material is initiated by the shock or pressure wave produced on initiation of the gas generating means.
6. A cartridge as claimed in any one of claims 1 to 5, wherein the energetic material is initiated by mechanical and/or electrical means which are activated on initiation of the primer.

7. A method for recycling a firearm comprising loading the firearm with a cartridge as defined in any one of claims 1 to 6, and firing the firearm.

1/3

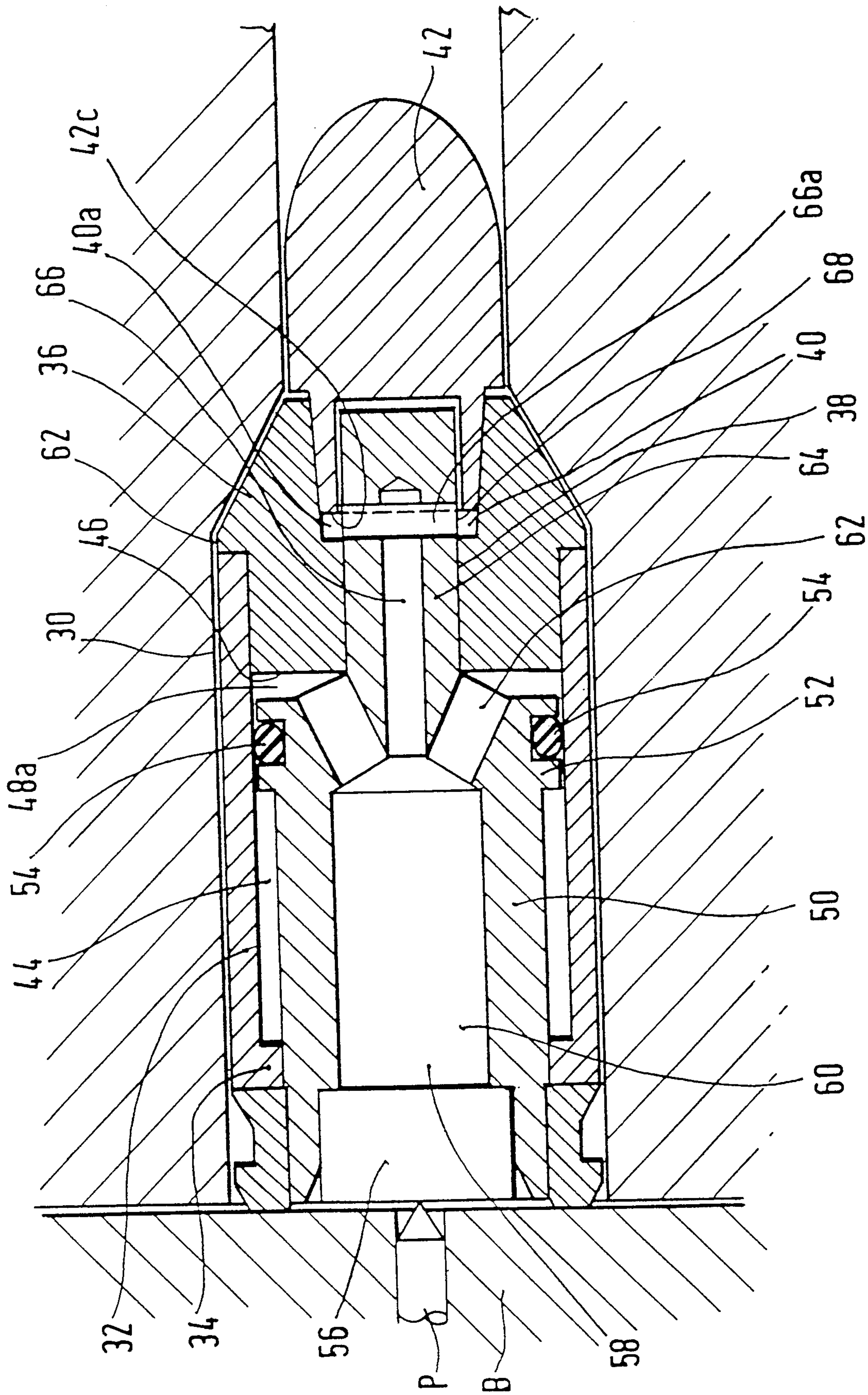

Fig.1.

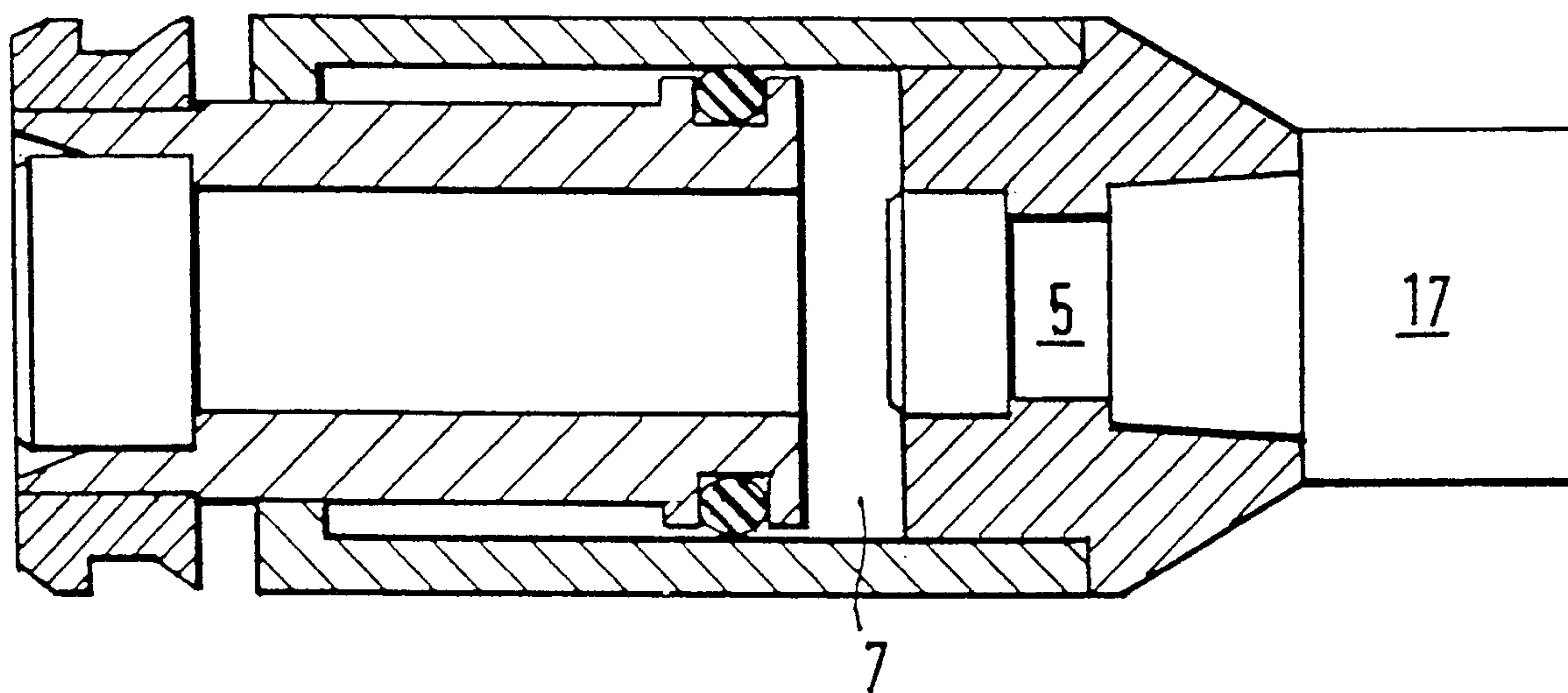
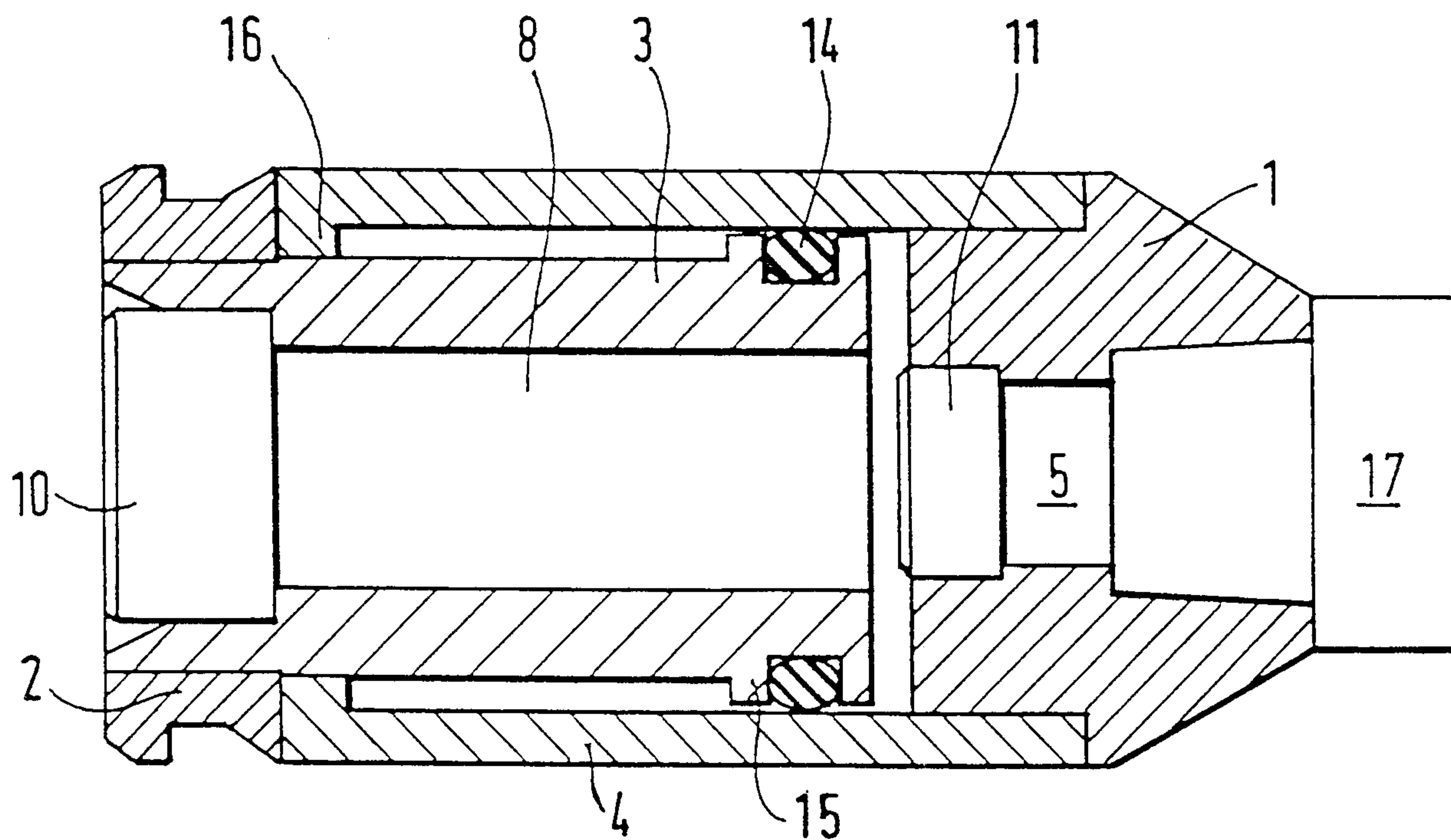

Fig.2.

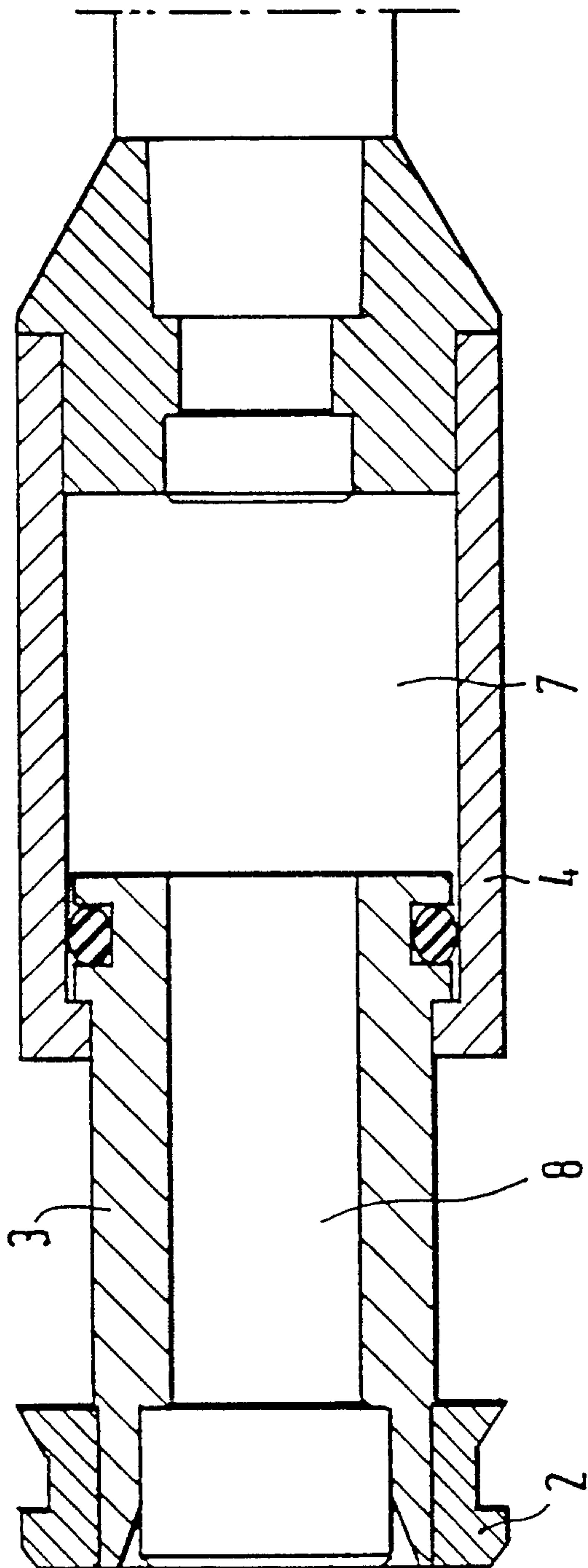

Fig.2. continued.

