

(19) World Intellectual Property Organization
International Bureau



(43) International Publication Date
5 July 2001 (05.07.2001)

PCT

(10) International Publication Number
WO 01/47425 A1

- (51) International Patent Classification⁷: A61B 17/70
- (21) International Application Number: PCT/IB00/01956
- (22) International Filing Date:
22 December 2000 (22.12.2000)
- (25) Filing Language: English
- (26) Publication Language: English
- (30) Priority Data:
99/16492 24 December 1999 (24.12.1999) FR
00/05655 3 May 2000 (03.05.2000) FR
- (71) Applicant (for all designated States except US): SOCIETE DE FABRICATION DE MATERIEL ORTHOPEDIQUE (SOFAMOR) [FR/FR]; 13, rue de la Perdrix, F-93290 Tremblay en France (FR).
- (72) Inventors; and
(75) Inventors/Applicants (for US only): CAVAGNA, Rémi [FR/FR]; 29, rue Sainte-Anne, F-56270 Ploemeur (FR). HUTEN, Denis [FR/FR]; 121, rue de la Jarry, F-94300 Vincennes (FR). MALANDAIN, Hugues [FR/FR]; 149, rue des Hirondelles, F-13300 Salon-de-Provence (FR). GOURNAY, José [FR/FR]; 36, avenue du Drap d'Or, F-77230 Dammartin-en-Goële (FR).
- (74) Agent: JACOBSON, Claude; Cabinet Lavoix, 2, place d'Estienne d'Orves, F-75441 Paris Cedex 09 (FR).
- (81) Designated States (national): AE, AG, AL, AM, AT, AU, AZ, BA, BB, BG, BR, BY, BZ, CA, CH, CN, CR, CU, CZ, DE, DK, DM, DZ, EE, ES, FI, GB, GD, GE, GH, GM, HR, HU, ID, IL, IN, IS, JP, KE, KG, KP, KR, KZ, LC, LK, LR, LS, LT, LU, LV, MA, MD, MG, MK, MN, MW, MX, MZ, NO, NZ, PL, PT, RO, RU, SD, SE, SG, SI, SK, SL, TJ, TM, TR, TT, TZ, UA, UG, US, UZ, VN, YU, ZA, ZW.

[Continued on next page]

(54) Title: PEDICLE SCREWS WITH INCLINED CHANNELS TO HOLD SUPPORT RODS

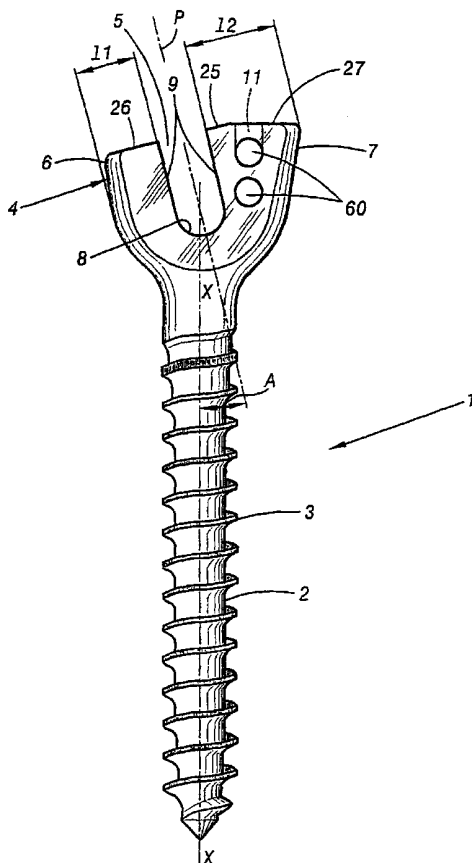

(57) Abstract: This invention is a pedicle screw (1), comprising a threaded rod (2) having a longitudinal axis (XX) and a head (4) in which there is a channel (5) adapted to receive a spinal support rod, and a means for blocking the rod; the channel is formed such that its longitudinal axial plane (P) is inclined relative to the longitudinal axis (XX) of the threaded rod. The head (4) of the screw being made up of two flanks (6, 7), a threaded hole (11) is formed in one of them; the inclination of the channel (5) relative to the axis of the threaded rod (2) makes it possible to place a tool for blocking the rod in the channel without this tool coming into contact with the muscle tissues delimiting the incision. Moreover, the threaded seat (11) permits the positioning of instruments without obstructing the channel for passage of the rod.



WO 01/47425 A1



(84) Designated States (regional): ARIPO patent (GH, GM, KE, LS, MW, MZ, SD, SL, SZ, TZ, UG, ZW), Eurasian patent (AM, AZ, BY, KG, KZ, MD, RU, TJ, TM), European patent (AT, BE, CH, CY, DE, DK, ES, FI, FR, GB, GR, IE, IT, LU, MC, NL, PT, SE, TR), OAPI patent (BF, BJ, CF, CG, CI, CM, GA, GN, GW, ML, MR, NE, SN, TD, TG).

Published:

— *With international search report.*

For two-letter codes and other abbreviations, refer to the "Guidance Notes on Codes and Abbreviations" appearing at the beginning of each regular issue of the PCT Gazette.

**PEDICLE SCREWS WITH INCLINED CHANNELS
TO HOLD SUPPORT RODS**

5 The present invention relates to bone screws with a thread adapted to be screwed into a bone, and a fixing means located the other end that is designed for attaching a spinal rod to the screw.

10 BACKGROUND OF THE INVENTION

 In order to maintain bones in specified orientation relationship, there are various known techniques for screwing a bone-fixing screw into bones in various parts of the body, such as the spine, and
15 combining rods with said implanted screw so that the rods will be positioned alongside the bones. The screws of the prior art are provided with a rod-fixing means. The rod-fixing means have an opening that is located either parallel to the axial direction of
20 thread or on the side thereof, but these solutions have problems; inserted rods slip out of place with the parallel arrangement, while with the latter, operators have to insert a rod at right angles to the axis of the thread, which can prove to be a difficult procedure.

SUMMARY OF THE INVENTION

In one aspect, this invention is a bolt for connecting a vertebra to a longitudinal member with a mounting portion at one end portion of the bolt and a connector portion at a second end of the bolt. The connector portion has a channel that is adapted to receive a spinal support rod and the longitudinal axial plane of the channel is oblique to the longitudinal axis of the mounting portion of the bolt. A screw is then threadably engaged into the connector portion in a manner that the longitudinal axis of the screw is substantially parallel to the longitudinal axial plane of the channel in the connector portion.

In another aspect, the invention is an apparatus to support the spine. The apparatus has a longitudinal member with at least one flat planar face formed therein that extends over at least part of the length of the longitudinal member. The apparatus also has two bolts. At least one of the bolts has a mounting portion at one end of the bolt and a connector portion at a second end of the bolt. The connector portion has a channel therein that is adapted to receive the longitudinal member and the channel is oblique to the longitudinal axis of the mounting portion of the bolt. The bolt then also has a screw that threadably engages the connector portion of the bolt to hold the longitudinal member in place.

In yet another aspect, the invention is also a bolt for connecting a vertebra to a longitudinal member with a mounting portion at one end portion of the bolt and a connector portion at a second end of the bolt. The connector portion has a channel that is adapted to receive a spinal support rod and the longitudinal axial plane of the channel is oblique to the longitudinal

axis of the mounting portion of the bolt. A screw is then threadably engaged into the wall in the channel of the connector portion so as to press against a longitudinal member residing in the channel when the screw is axially displaced out from the wall.

In still another aspect of the invention, the invention is an apparatus to support the spine. The apparatus includes at least one support rod and at least two pedicle screws. The pedicle screws have a head disposed at a one end and male threads disposed at the other end. The head portion has a channel therein that is adapted to receive the support rod. The male threads have an outside diameter and a core with a core diameter. The core diameter remains substantially constant between the screws, while the external diameter of the threads increases from one screw to the next screw.

In the case of a screw, the longitudinal centre plane of the channel containing the longitudinal axis of the threaded rod, the channel extends along the axis of the threaded rod. As the latter is also necessarily inclined in relation to the margins of the incision of the spine so as to be able to be anchored in a pedicle, the instruments employed for positioning these screws come into contact with the flesh and tissues bordering the incision, during the screwing and the other operations on the screw.

Thus, an object of the invention is to make available a bone-anchoring member which is such that the instruments associated with it can be used without coming into contact with the tissues defining the margin of the incision.

According to the invention, the channel is formed such that its longitudinal axial plane is

inclined relative to the longitudinal axis of the bone-anchoring member.

Another object of the invention is to provide a solution to the following problem. It has been found
5 that support rods of relatively small diameter, for example 3 mm, give rise to a considerable percentage of breaks following a certain period of use on the patient. It is therefore desirable to increase the flexural strength of these rods, but without increasing their
10 diameter. A solution to this problem would be to use a pair of rods instead of one. For a rod having a diameter of 3 mm, for example, a pair of rods thus combined is equal in terms of flexural strength to a rod having a diameter of 3.6 mm. However, such a
15 solution considerably increases the size and the cost price of the instrumentation since it requires two rods instead of one.

The invention therefore aims to provide a satisfactory solution to this problem.

20 According to the invention, at least one longitudinal flat is formed on the support rod and extends over at least part of the length of the rod, in such a way that the latter has, in a longitudinal axial plane of the channel, a different flexural strength
25 depending on whether its flat extends perpendicular or parallel to the said longitudinal axial plane of the channel.

Thus, depending on whether the rod is oriented with its flat parallel to the longitudinal axial plane
30 of the channel or by contrast perpendicular to this plane, the flexural strength of this rod will be different. This strength is of course greater when the flat is parallel to the axial plane of the channel.

With such an arrangement it is therefore possible, when so required, to increase the flexural strength of the rod by providing it with one or two flats and by modifying its orientation. This affords
5 the advantage of avoiding the use of two identical rods, thereby reducing the size of the instrumentation and its cost price.

According to one embodiment of the invention, the rod has two flats parallel to one another and
10 diametrically opposite, the rod having parts of circular cross section between its flats.

Other particulars and advantages of the invention will become clear from the following description in which reference is made to the attached
15 drawings which show a number of illustrative and nonlimiting embodiments.

BRIEF DESCRIPTION OF THE DRAWINGS

Figure 1 is a front view, on an enlarged scale, of a pedicle screw according to the invention, intended for instrumentation for supporting the spine.

5 Figure 2 is a perspective view, on an enlarged scale, of the pedicle screw in Figure 1.

Figure 3 is a top view of the head of the screw in Figures 1 and 2.

10 Figure 4 is a view, in a horizontal plane, of two pedicle screws anchored in a vertebra, one of them according to the invention and the other according to the prior art.

Figure 5 is a front view of a pair of bone screws according to the invention, joined via a
15 transverse connection device.

Figure 6 is a perspective view of an instrument which can advantageously be used in combination with a screw according to the invention.

20 Figure 7 is a partial longitudinal section, on an enlarged scale, of the head of a screw according to the invention and of the lower end of the instrument in Figure 6, positioned on the head of the screw.

Figure 8 is a partial front view of two bone screws which can be used in a spinal instrumentation
25 according to the invention.

Figure 9 is a perspective view of a support rod for spinal instrumentation, according to a third embodiment of the invention.

30 Figures 10 and 11 are front views in partial section showing the head of a screw according to Figures 1 to 3 associated with a support rod according to Figure 9, arranged in a first orientation in Figure 10 and in a second orientation in Figure 11.

Figure 12 is a front view of spinal osteosynthesis instrumentation according to the invention.

5 Figure 13 is a partial perspective view, on an enlarged scale, of a second embodiment of the screw in Figures 1 to 3 and of its means for blocking the support rod.

Figure 14 is a partial side view of the screw in Figure 13.

10 Figure 15 is a longitudinal section of the means for blocking the rod associated with the screw in Figures 13 and 14.

Figure 16 is a partial perspective view, on an enlarged scale, of a third embodiment of the screw in 15 Figures 1 to 3 and of its means for blocking the rod.

Figure 17 is a partial section of the screw in Figure 16.

Figure 18 is a longitudinal section of the means for blocking the screw in Figures 16 and 17.

20 Figure 19 is a partial perspective view, on an enlarged scale, of a fourth embodiment of the screw in Figures 1 to 3 and of its means for blocking the support rod.

Figure 20 is a partial section of the screw in 25 Figure 19.

Figure 21 is a longitudinal section of the blocking means on the screw in Figures 19 and 20.

Figure 22 is a front view of the screw along the arrow K in Figure 19.

30 Figure 23 is a side view of a bone-anchoring hook according to the invention.

DETAILED DESCRIPTION OF THE PREFERRED
EMBODIMENTS

The pedicle screw 1 represented in Figures 1 to 3 is intended to form part of instrumentation for supporting the spine. This instrumentation has at least one support rod dimensioned to extend along at least two vertebrae and at least two pedicle screws for bone anchoring, such as pedicle screw 1.

Screw 1 has a threaded rod 2 provided with a bone thread 3 and a longitudinal axis X-X, and a head 4 in which there is a channel 5 having a U-shaped cross section and a longitudinal axial plane P. The channel 5, delimited by two flanks 6, 7 of the head 4, is adapted to receive a generally cylindrical support rod and for this purpose preferably has a bottom 8 of circular cross section. On its walls 9 there are threaded parts 10 intended to receive a screw (not shown) for blocking a support rod (not shown). This rod can be smooth or have a roughened surface or it can be the type of rod 36 which will be described below.

The U-shaped channel 5 is formed such that its longitudinal axial plane P is inclined by an angle A different from zero degrees relative to the longitudinal axis X-X of threaded rod 2. Thus, the rectilinear walls 9, which delimit either side of threaded parts 10 and channel 5 with its circular bottom 8, have an inclination A relative to the axis X-X.

This inclination A can have a value preferentially up to about 65 degrees (cf. Fig. 19-20) in either direction.

The flanks 6 and 7 delimiting the U-shaped channel 5 may have different respective widths 11, 12 in a direction perpendicular to the longitudinal axial

plane P. In addition, a threaded hole 11 is formed in the flank 7 whose width 12 is the greater. This hole 11 is intended to receive a threaded member such as a screw 12 (Figure 7) for fixing a piece to the screw 1, for example an instrument 13 (Figures 6 - 7).

Instrument 13 has a general tubular shape with an angled lower end 14 in which there is an orifice 15 for introducing the screw 12 into the threaded hole 11. Also arranged in the instrument 13 is an axial bore 16 which is open to each end of instrument 13, the angled end 14 being adapted to be applied on the end faces of the branches 6, 7 while the screw 12 can be screwed into the hole 11, in such a way that the bore 16 is coaxial with the threaded parts 10 (Figure 3). The geometry of the head 4 of the screw 1 thus makes it possible to position the instrument 13 in such a way that a tool can be introduced axially into the bore 16, precisely and with ease into the axis of the channel 5, in order to easily carry out the screwing therein of a threaded plug for blocking the support rod passing through the channel 5.

Figure 4 shows a screw 1, according to one embodiment of the invention, screwed into a pedicle of a vertebra V and also a screw 17, according to the prior art, screwed into the other pedicle of the same vertebra. To permit positioning of the screws, the surgeon has first made an incision I in the spine by the posterior approach, this incision I being delimited laterally by muscle tissues M. The screw 17 according to the prior art includes a head 18 which is integral with a threaded rod 19 and has a U-shaped channel 21 whose axial plane contains the longitudinal axis of the rod 19. The flanks 22 delimiting the channel 21 are thus similar in their dimensions and are symmetrical in

relation to this axial plane and to the axis of the rod 19. As the screw 17 is also inclined in the pedicle in the direction of the adjacent tissues M, the result is that a tool 23 for screwing in the plug for blocking the support rod in the channel 21, necessarily placed in the axis of the channel 21, will interfere in an undesirable manner with the muscle tissues M.

By contrast, by virtue of the inclination of the channel 5 relative to the axis X-X of the screw 1 according to the invention, the screwing tool 23 can be introduced into the channel 5 without coming into contact with the tissues M.

Figure 5 illustrates the use of a transverse connection device 24 by virtue of the design of the wider flank 7 of the screw 1. The end face of this wide flank 7 is made up of a first plane part 25, situated in the plane of the plane face 26 forming the end of the flank 6, and of a second plane part 27 forming an obtuse angle with the plane part 25 (Figure 1). The transverse connection device 24 is made up of a plate 28 whose ends bear on the plane part 27 of two screws 1, and of two members 29 for blocking the plate 28 on the screws 1. Each member 29 includes a threaded rod (not visible in Figure 5) passing through a corresponding orifice of the plate 28 and being screwed into the associated threaded hole 11.

Figure 8 shows two pedicle screws 31 and 32 for anchoring instrumentation for supporting the spine into bone. Each screw comprises a core 33 of diameter d , equipped with a respective thread 34 and 35, each also having an external diameter d_1 , d_2 , and a head (not shown). The diameter d of the core 33 is identical for both the screws 31, 32, while the external diameter of their respective threads 34, 35 increases from d_1 to

d2, for example from 5.5 to 7.5 mm. More generally, in the set of screws provided for by the invention, each screw such as 31, 32 comprises a cylindrical core 33 whose diameter is constant for all the screws, while
5 the external diameters d1, d2 of their respective threads 34, 35 increase from one screw to the other, between defined limits. These screws can be of the conventional type, such as the screw 17 shown in Figure 4, or can be according to the invention, such as the
10 screw 1.

The identically rigid screws 31, 32 of this set do not have too great a diameter in relation to that of the support rods with which they may be associated. The diameter of the core 33 is of course chosen so that all
15 the screws used in the spinal instrumentation in question have a sufficient mechanical strength, while the height of their thread varies from one screw to the other. In other words, the diameter of the core 33 of the screw remains identical from one screw to the
20 other, irrespective of the external diameter of its thread.

Figures 9 to 11 illustrate another embodiment of the invention in which a pedicle screw 1 is associated with a support rod 36 on which at least one
25 longitudinal flat 37 is formed over at least part of the length of the rod 36, the remaining part 38 of which is cylindrical. In the example illustrated in Figures 9 to 11, two longitudinal flats 37 are arranged on the rod 36 and positioned diametrically opposite
30 each other over part of the length of the rod. In addition, these flats 37 are identical, that is to say they are symmetrical with respect to the longitudinal axis Y-Y of the rod 37. For this reason, the latter has, in the longitudinal axial plane P of the channel 5

of the head 4, a different flexural strength depending on its orientation in this channel 5. More precisely, the flat or flats 37 can extend either perpendicular to the said axial longitudinal plane P of the channel 5 (Figure 10) or parallel to it (Figure 11). Between the flats 37, the rod 36 has two diametrically opposite parts 39 with contours of circular cross section.

The rounded bottom 8 of the channel 5 has a radius of curvature substantially equal to the radius of curvature of the circular parts 39. For this reason, when the rod 36 is positioned in such a way that its flats 37 are parallel to the axial plane P (Figure 11), one of the circular contours 39 will bear on the circular bottom 8 by fitting it. Advantageously, the means for blocking the rod 36 in the channel 5, formed for example by a threaded plug 40, has a bearing face which comes into contact with the rod 36.

When the rod 36 is oriented with its flats 37 perpendicular to the axial plane P of the channel 5 (Figure 10), its opposite circular contours 39 bear on rounded shoulders 43 which connect the bottom 8 to the plane walls of the channel 5 and whose radius of curvature is substantially equal to that of the circular contours 39. In this case, the plane end face of the plug 40 is applied tightly on one of the flats 37.

The arrangement of one or two flats such as 37 over at least part of the length of the support rod 36 thus makes it possible to vary its flexural strength in the axial plane P of the channel 5, depending on its orientation: when the flats 37 are perpendicular to the axial plane P (Figure 10), its flexural strength in this plane is minimal, whereas when these flats 37 are placed parallel to the axial plane P (Figure 11), its

flexural strength is much greater. For this reason, the breaks which could occur hitherto with entirely cylindrical rods can be reduced by using a rod with a greater diameter and with a flat or flats, such as 36, suitably oriented in the channel 5.

The flat or flats make it possible to adapt the "stiffness" of the assembly to the pathology of the patient, by varying the orientation of the rod 37 (Figures 10 and 11).

By way of indicative and nonlimiting numerical example, for a rod having a diameter of 4 mm, the flats 37 can be separated by a distance of 3 mm. In a possible alternative, the flanks 6, 7 of the screw 1 can have equal widths. Similarly, the function of the threaded hole 11 can be provided by a threaded extension in the same location or by a geometry on the sides such as holes 60 or grooves 107 (Figures 19 and 22), making it possible to grip the screw via an instrument.

Figure 12 illustrates instrumentation according to the invention used in conjunction with prior art screws 52, including two cylindrical vertebral rods 50 extending along a segment of the spine comprising four vertebrae 51. These rods are also equipped with pedicle screws 1, which are equipped with threaded plugs 53 for blocking the rods 50, and also, at the ends of the said rods, with bone-anchoring hooks 52 also provided with threaded plugs 53.

The pairs of screws 1 are connected by transverse connection devices 24.

Of course, the cylindrical rods 50 can be replaced by rods 36 with flats 37, and the plugs 53 can be replaced by plugs 40 or 41.

Figures 13 to 15 illustrate a second embodiment of the screw in Figures 1 to 3. In this embodiment, the screw 61 includes a head 62 consisting of two flanks 63, 64 of unequal width and delimiting between them a channel 65 of U-shaped profile. Formed on one side of the body 62 there is also a hole 66 for gripping the screw via an instrument (not shown). The means for blocking the support rod 50 is a threaded plug 67 provided with a collar 68 which radially delimits two threaded parts 41 and 69. In one of the flanks delimiting the channel 65, namely in the wider flank 63, a threaded hole 71 is formed which has an interruption 72 on its part contiguous with the channel 65, so as to communicate laterally with the latter. In this way, after the plug 67 has been screwed into the hole 71, the collar 68 comes into blocking engagement on the rod 50 placed in the channel 65. The upper thread 41 projecting above the collar 68 can be joined to a transverse connection plate, such as 24 (Figure 12), to which it is fixed by a nut (not shown).

Formed in the threaded plug 67 there is a profiled impression 73 for receiving a corresponding screwing tool (not shown). It will be noted that the collar 68 has an asymmetrical profile formed by a flank 68a, inclined in such a way as to be able to bear on the rod 50 at the end of screwing of the plug 67, and a second flank 68b extending radially, almost perpendicular to the longitudinal axis of the plug 67.

In the third embodiment of the screw 75 shown in Figures 16 to 18, the head of the screw 75 consists of a short and fairly thin flank 76 and of a second wider flank 77 which extends beyond the height of the flank 76. These two flanks delimit a channel 78, the bottom of which has an axial plane P at a certain

inclination to the longitudinal axis XX of the bone-anchoring member 75, and the end walls 79, 81 of which have an axial plane Z more inclined relative to the axis XX than is the axial plane P.

5 These walls 79, 81 delimit an entry for the support rod which is thereby guided as far as the bottom of the U-shaped channel 78. Formed in the wide flank 77 there is a threaded hole 82 whose lower truncated part opens into the channel 78 in the zone
10 located between the entry walls 79 and 81 (Figure 17). In other words, the threaded wall of the hole 82 is interrupted at its part contiguous with the channel 78. The screw 75 is completed by a threaded plug 83 provided with an impression 84 for screwing. The rod 50
15 having been placed beforehand in the channel 78, the end cone 42 of the plug 83 comes into blocking engagement on the rod 50 (Figure 16) which is thus blocked in the channel 78 after sufficient screwing. As in the case of the plug 67 in Figure 13, the upper part
20 of the thread of the plug 83 can be used with a transverse connection plate (not shown) and a locking nut.

In the fourth embodiment illustrated in Figures 19 to 22, the screw 85 comprises a channel 86 receiving
25 a support rod 50 and delimited by two flanks 87 and 88. The flank 88 ends in a rectilinear part which is tangent to the cylindrical bottom 86a of the channel 86. This rectilinear part is continued via a plane surface 89 delimiting a second flank 91, of the screw
30 head, greatly inclined relative to the longitudinal axis XX of the screw 85, in the example shown by about 60°. The bottom 86a is thus connected to a plane surface 88, 89, in which there is a threaded hole 92.

Lateral grooves 107 are formed on the sides of the flanks 88, 91 to permit gripping of the screw 85 by an instrument (not shown).

The screw 85 is equipped with a threaded plug 5 93 preferably with an inverse pitch and equipped with a head 94 consisting of a radially projecting collar. The collar 94 delimits an end span 95 inclined relative to the longitudinal axis of the plug 93 and directed towards the outside of the hole 92 when the plug 93 is 10 screwed into the latter (Figure 19). The span 95 is connected to a radial surface 96 completing the collar 94. A preliminary insertion of the plug is effected at the works, the plug being delivered pre-assembled on the screw.

15 To use this embodiment, the surgeon screws the plug 93 into the hole 92, then places the rod 50 in the channel 86. The plug 93 is screwed in by turning it in the opposite direction to the normal direction in the case where its pitch is inverse. After putting the rod 20 50 into place, the surgeon proceeds to screw the plug 93 in the opposite direction to the previous one, that is to say in the clockwise direction. By this means, the plug 93 begins to emerge from the hole 92 until its span 95 comes to bear on the rod 50 and blocks it 25 against the inner circular wall of the channel 86 (Figure 19).

The plug 63 can also be provided with a normal pitch, and in this case the rotations of this plug are reversed.

30 Figure 23 illustrates a bone-anchoring member 97 consisting of a hook formed by a body 98, having a longitudinal axial plane XX, and a head 99 delimiting a U-shaped channel 101 between two flanks 102 and 106. These latter are provided with an internal threading

permitting screwing of a member for blocking the rod 50
in the channel 101. The axial plane P of the channel
101 is inclined relative to the longitudinal axial
plane XX of the body 98 by a variable angle A, as in
5 the case of the screw 1 already described. Of course,
the same applies to the other screws described above
(Figures 10 - 11) which can be replaced in the same way
by a hook. In general terms, the arrangement forming
the subject of the invention can be used on all types
10 of bone-anchoring hooks: thus, the embodiments in
Figures 13 to 21 can be used on hooks.

The present application hereby incorporates by
reference French Patent Application Number FR 99 16492
filed 24 December 1999 and French Patent Application
15 Number FR 00 06655 filed 3 May 2000 each in their
entirety and claims priority to each in accordance with
the Paris Convention.

CLAIMS

1. A bolt for connecting a vertebra to a longitudinal member, comprising:

5 a mounting portion disposed at a first end portion of said bolt, said mounting portion having means for engaging a vertebra, said mounting portion having a longitudinal axis; and

10 a connector portion disposed at a second end portion of said bolt; said connector portion having a channel therein that is adapted to receive the longitudinal member, the channel having a longitudinal axial plane, said longitudinal axial plane being oblique to said longitudinal axis of said mounting portion; and

15 a screw having a longitudinal axis, said screw threadably engaged into said connector portion in a manner that the longitudinal axis of said screw is substantially parallel to the longitudinal axial plane of the channel in said connector portion, and wherein a
20 least a portion of said screw may contact the longitudinal member.

2. The bolt of claim 1, wherein said screw is threadably engaged into the channel of said connector portion.

25 3. The bolt of claim 1, wherein the longitudinal axial plane is inclined relative to the longitudinal axis of said mounting portion by an angle having a value between zero and 65 degrees.

30 4. The bolt of claim 1, where said screw is a threaded plug with a collar projecting radially from said plug, and wherein a portion of said collar extends into the channel in said connector portion.

5. The bolt of claim 1, wherein said connector portion has a threaded hole therein and the threaded

hole opens into the channel in said connector portion, and wherein said screw is threadably engageable against a longitudinal member residing in the channel.

6. The bolt of claim 1, wherein the means for engaging a
5 vertebra is male threads.

7. The bolt of claim 1, wherein the means for engaging a vertebra is a hook.

8. An apparatus to support the spine, comprising:

a longitudinal member, said longitudinal member
10 having at least one flat planar face formed therein that extends over at least part of the length of the longitudinal member; and

two bolts, at least one of said bolts including a mounting portion disposed at a first end portion of
15 said bolt and a connector portion disposed at a second end portion of said bolt, said mounting portion having means for engaging a vertebra, said mounting portion having a longitudinal axis, said connector portion having a channel therein that is adapted to receive the
20 longitudinal member, the channel having a longitudinal axial plane, said longitudinal axial plane being oblique to said longitudinal axis of said mounting portion; and a screw having a longitudinal axis and threadably engageable into said connector portion and
25 wherein at least a portion of said screw may contact the longitudinal member when the longitudinal member is placed in the channel of said connector portion.

9. The apparatus of claim 8 wherein the longitudinal axis of said screw is substantially parallel to the
30 longitudinal axial plane of the channel in said connector portion.

10. The apparatus of claim 8 wherein said longitudinal member has two flat planar faces formed therein on

diametrically opposite sides of said longitudinal member.

11. The apparatus of claim 8 wherein the channel in said connector portion has a concave bottom with a substantially round cross-section and at least a portion of said longitudinal member has a complementary rounded face to mate with the concave bottom of the channel.

12. The apparatus of claim 11 wherein the complementary rounded face of said longitudinal member is located adjacent the flat planar face of said longitudinal member.

13. The apparatus of claim 8 wherein said screw has a distal end and the distal end is flat to engage the flat planar face of the longitudinal member.

14. A bolt for connecting a vertebra to a longitudinal member, comprising:

a mounting portion disposed at a first end portion of said bolt, said mounting portion having means for engaging a vertebra, said mounting portion having a longitudinal axis; and

a connector portion disposed at a second end portion of said bolt; said connector portion having a channel therein that is adapted to receive the longitudinal member, the channel having a longitudinal axial plane, said longitudinal axial plane being oblique to said longitudinal axis of said mounting portion, the channel being defined by at least one wall; and

a screw having a longitudinal axis, said screw threadably engaged into said wall in the channel of said connector portion, said screw being positioned to press against a longitudinal member residing in the

channel when the screw is axially displaced out from said wall.

15. The bolt of claim 14, wherein the longitudinal axial plane is inclined relative to the longitudinal axis of said mounting portion by an angle having a value between zero and 65 degrees.

16. The bolt of claim 14, wherein the means for engaging a vertebra is male threads.

17. The bolt of claim 14, wherein the means for engaging a vertebra is a hook.

18. An apparatus to support the spine, comprising at least one support rod and at least two pedicle screws, each of said pedicle screws having a head disposed at a first end portion and male threads disposed at a second end portion, said head portion having a channel therein that is adapted to receive the support rod, said male threads having an outside diameter and a core with a core diameter, said screws further characterised in that the core diameter remains substantially constant between said screws, while the external diameter of the threads increases from one screw to the other.

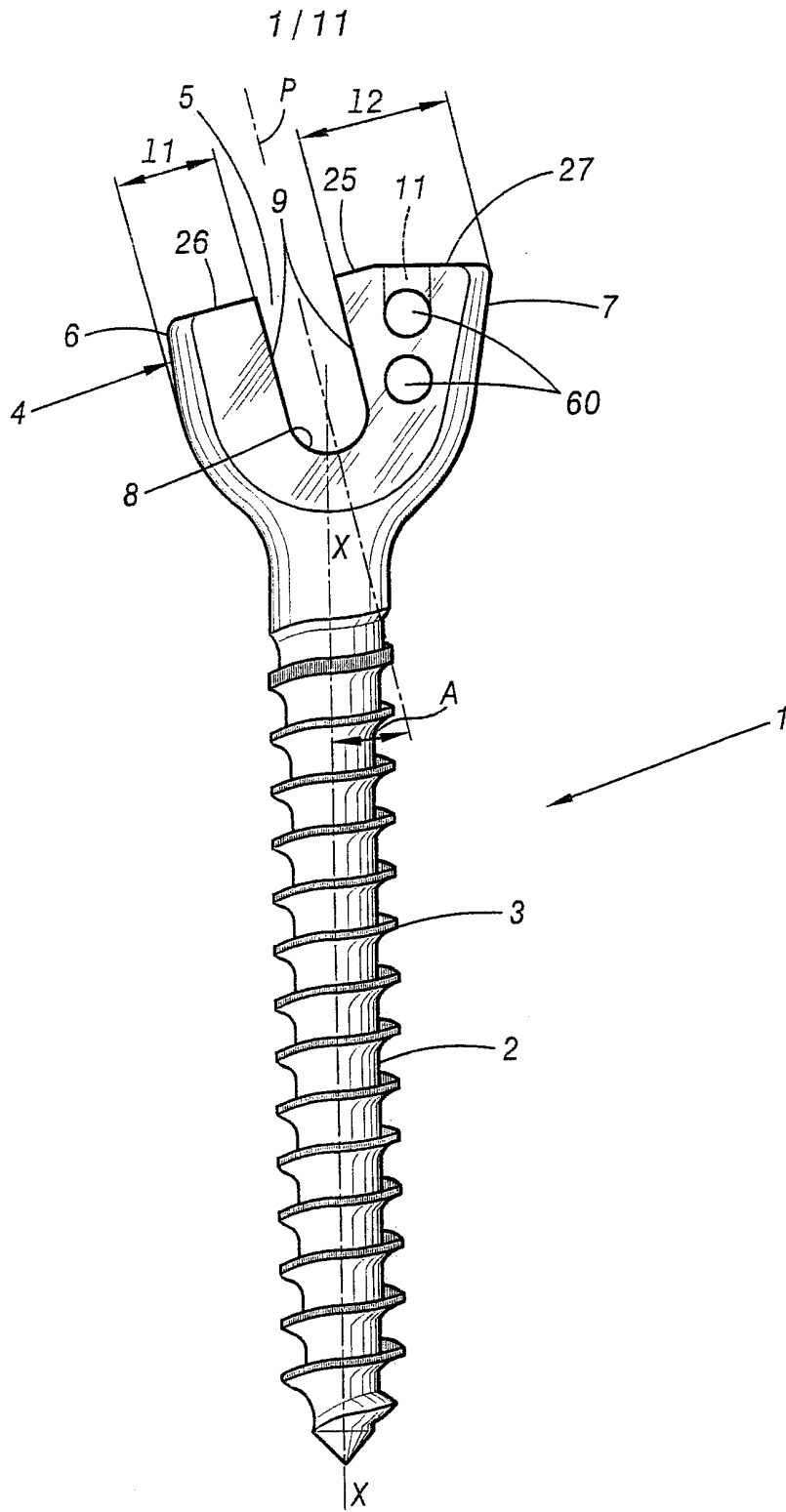

FIG. 1

2/11

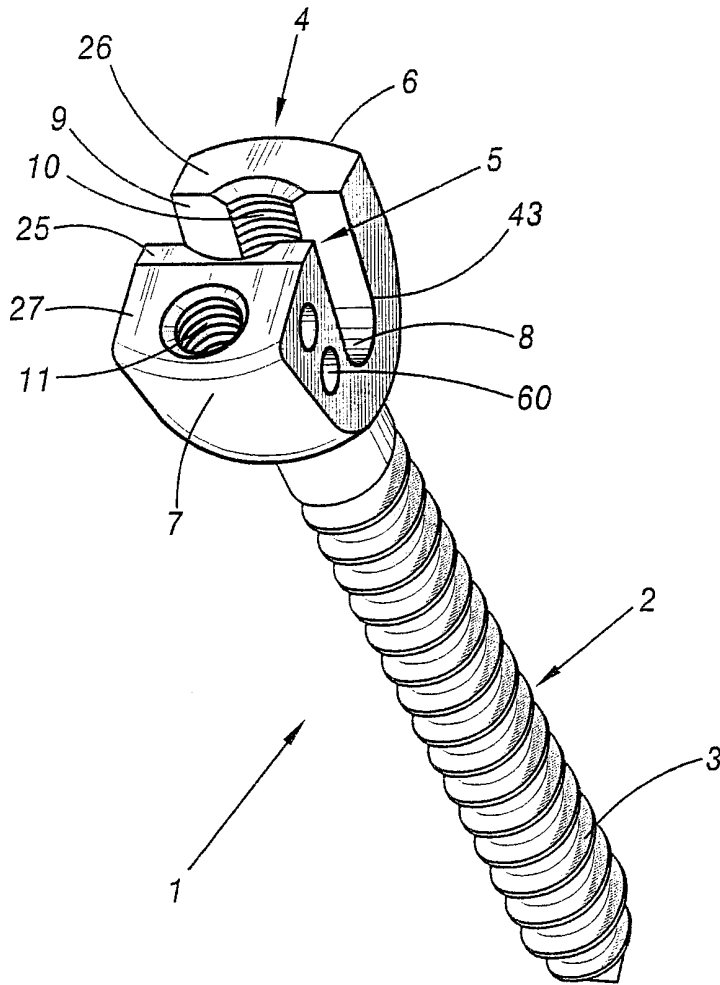

FIG. 2

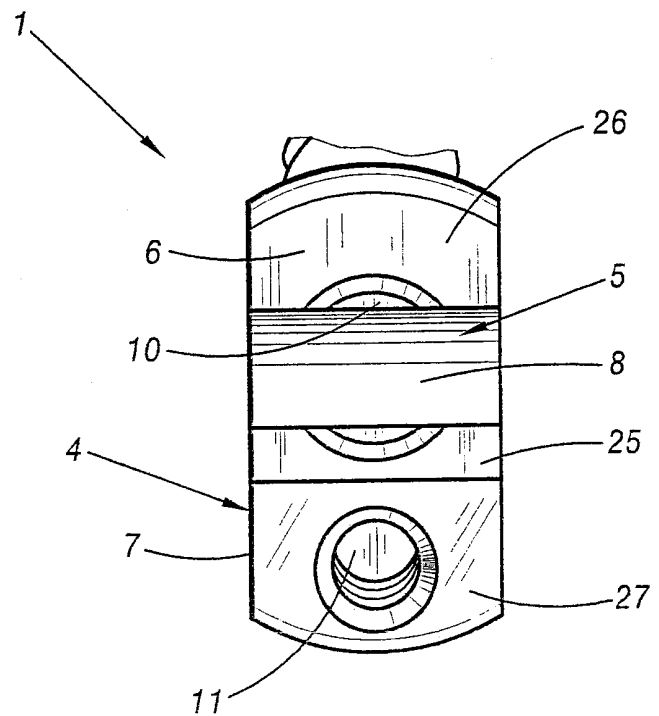

FIG. 3

3/11

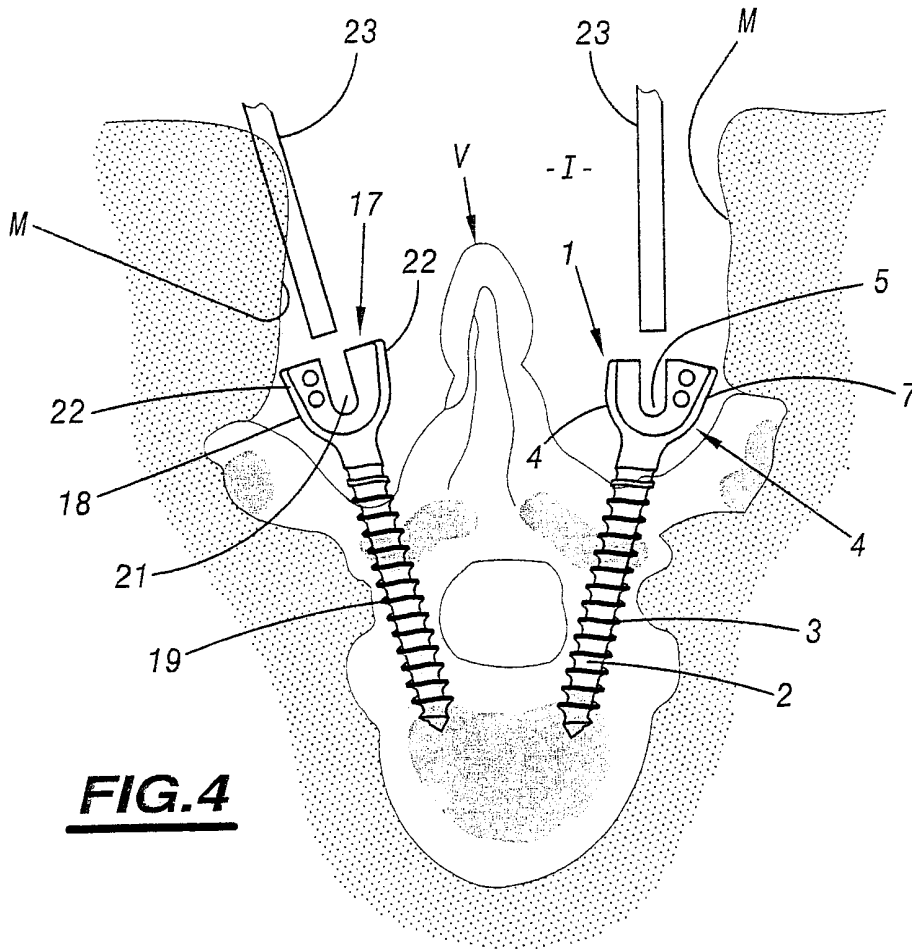

FIG. 4

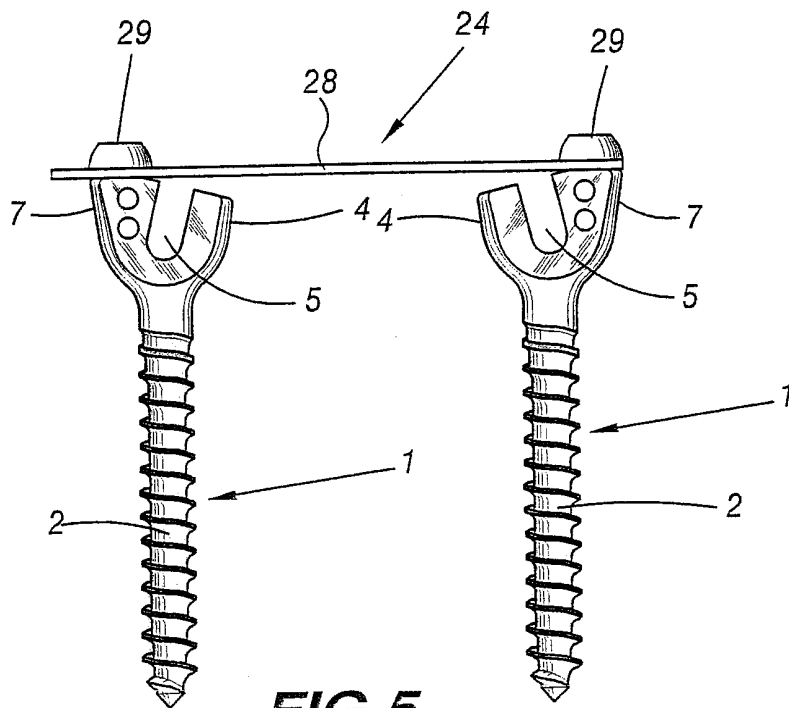
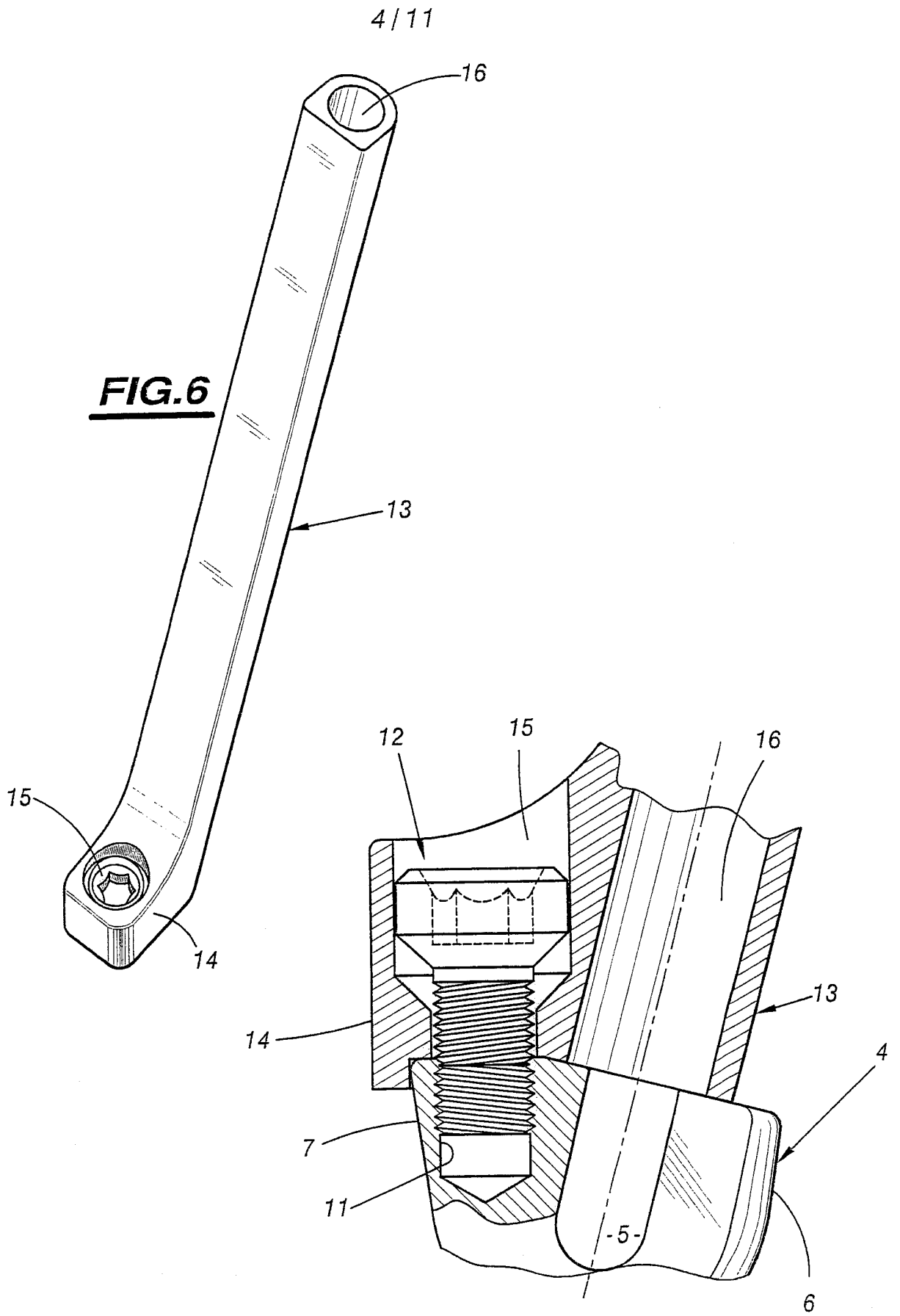

FIG. 5



5/11

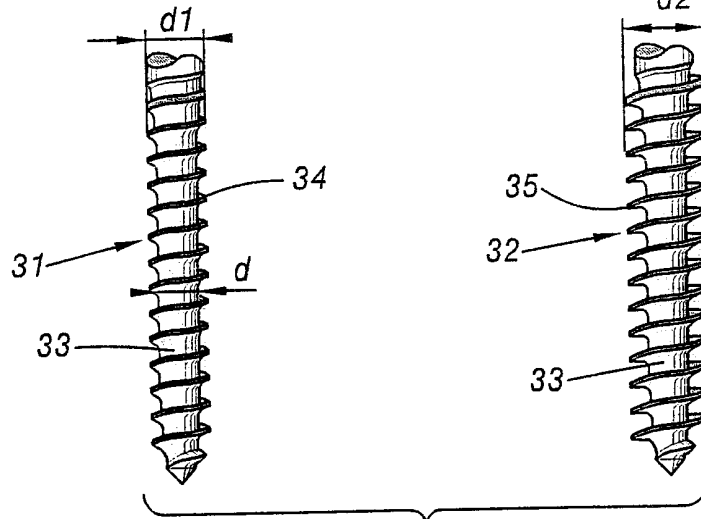

FIG. 8

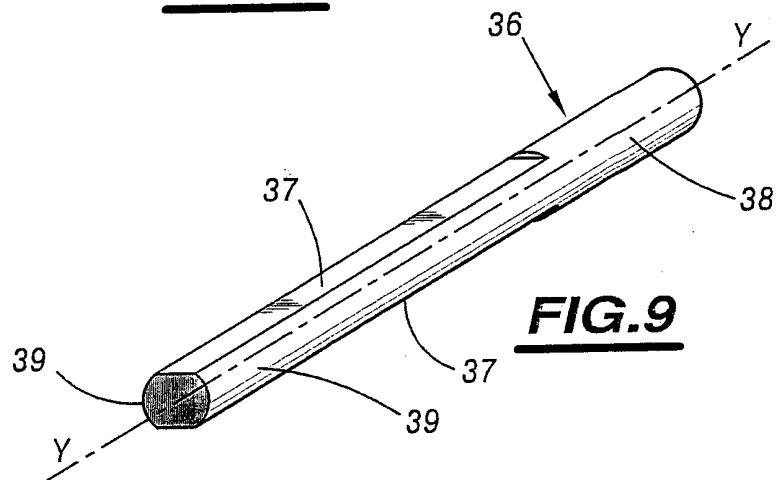

FIG. 9

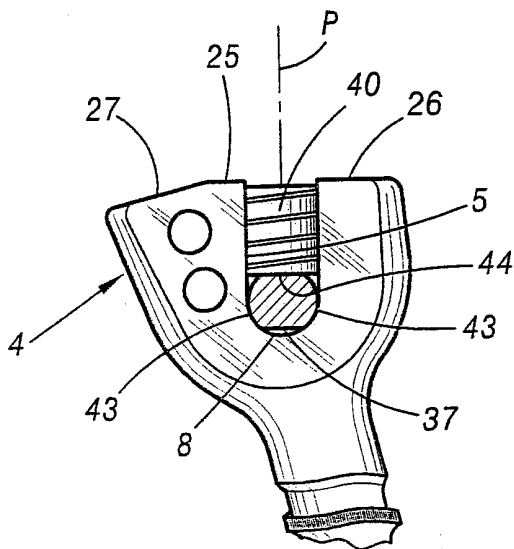

FIG. 10

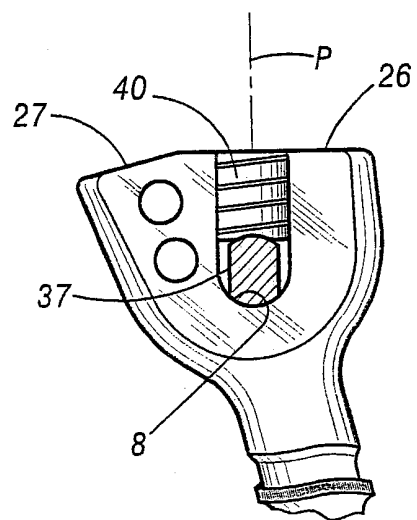

FIG. 11

6/11

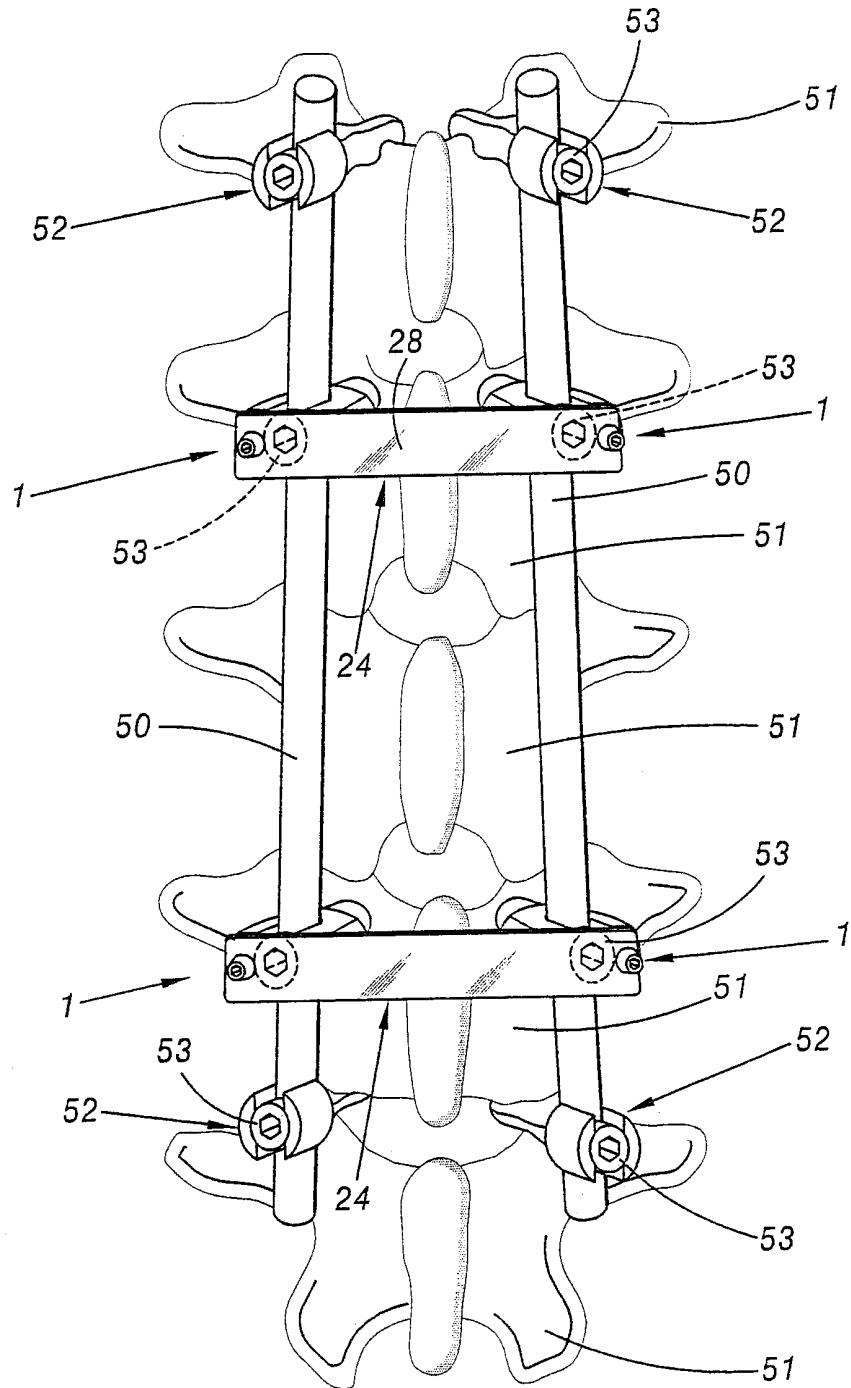

FIG. 12

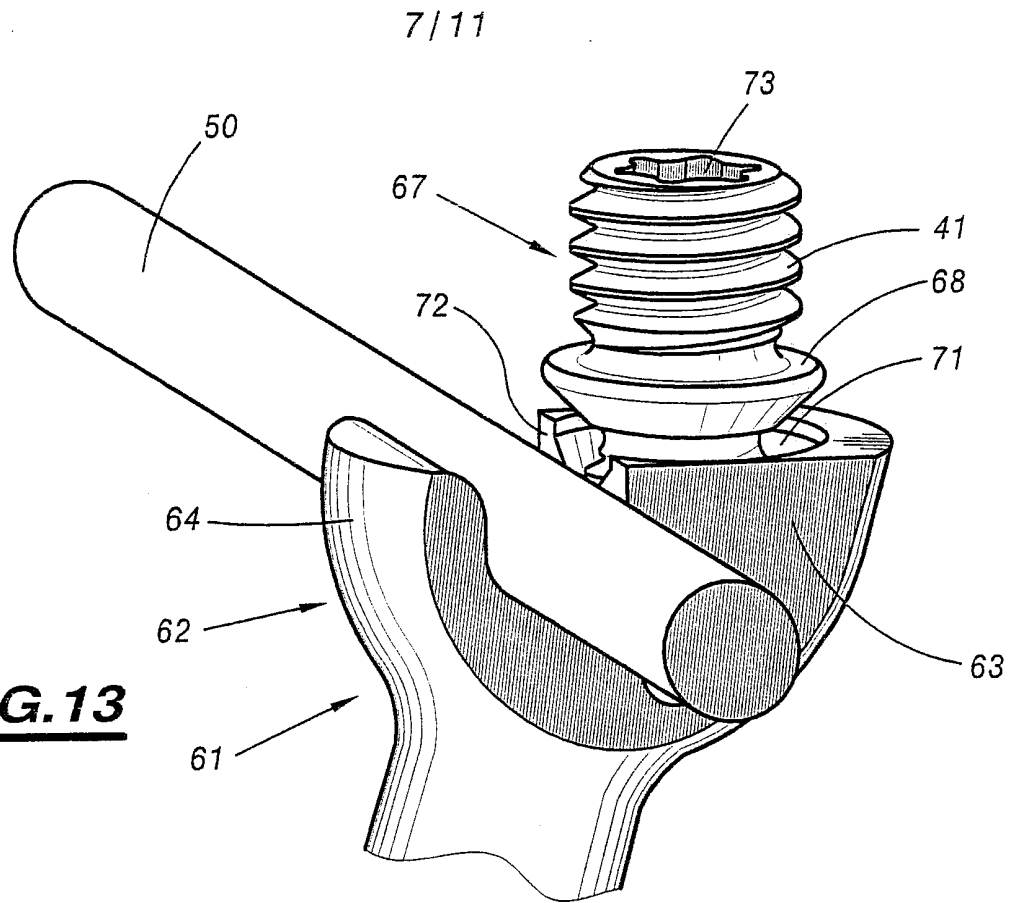

FIG. 13

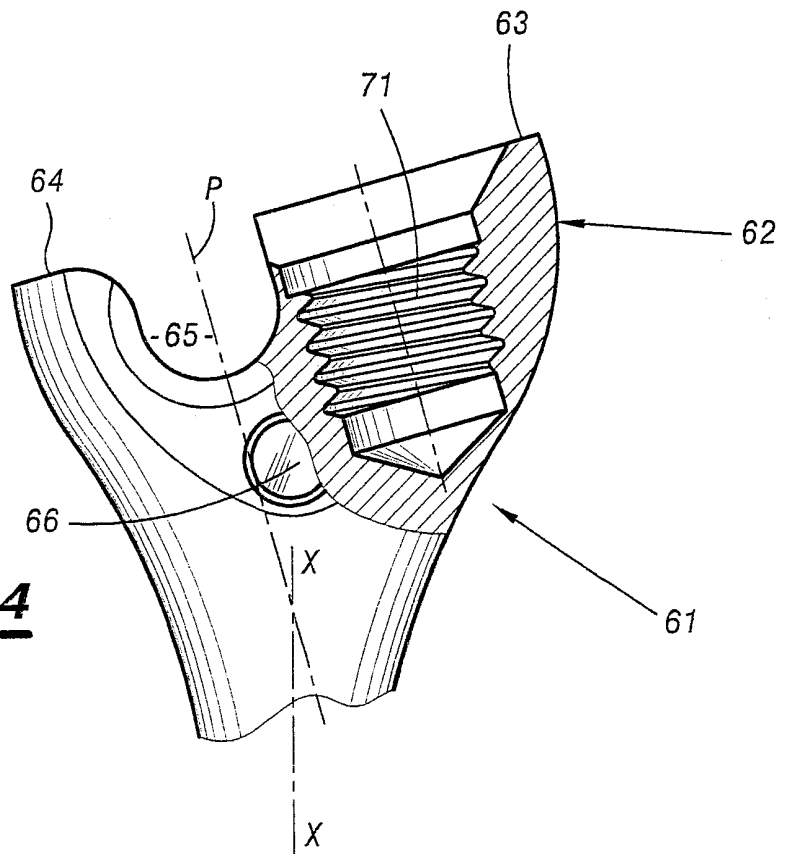

FIG. 14

8/11

FIG. 15

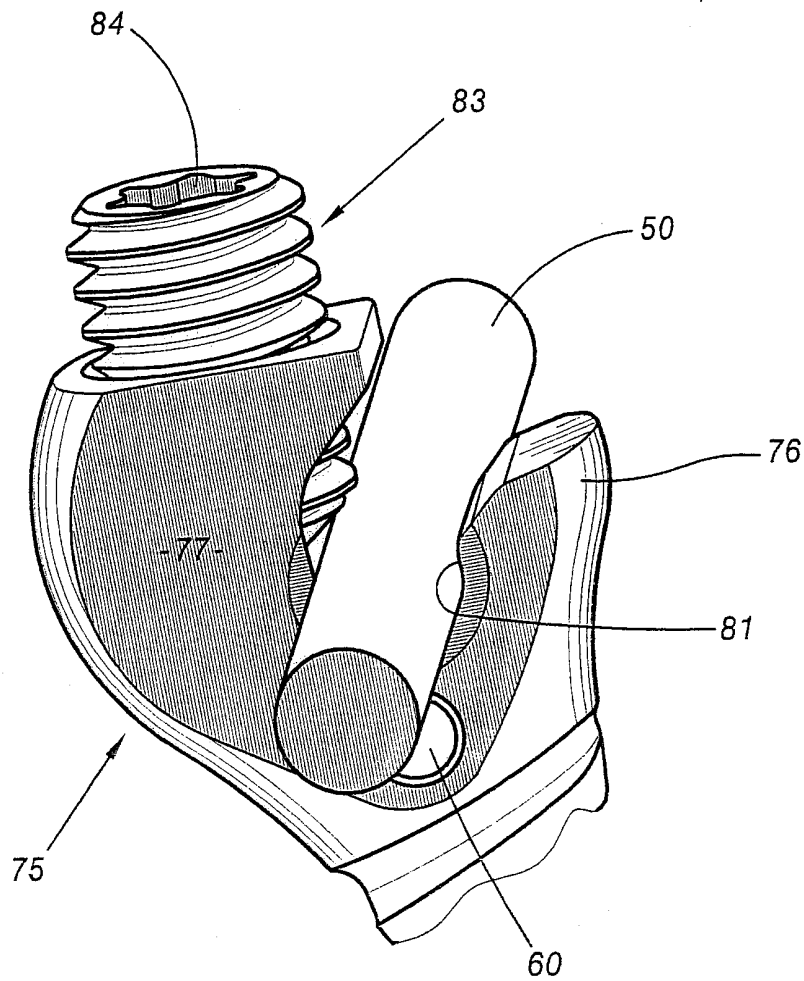
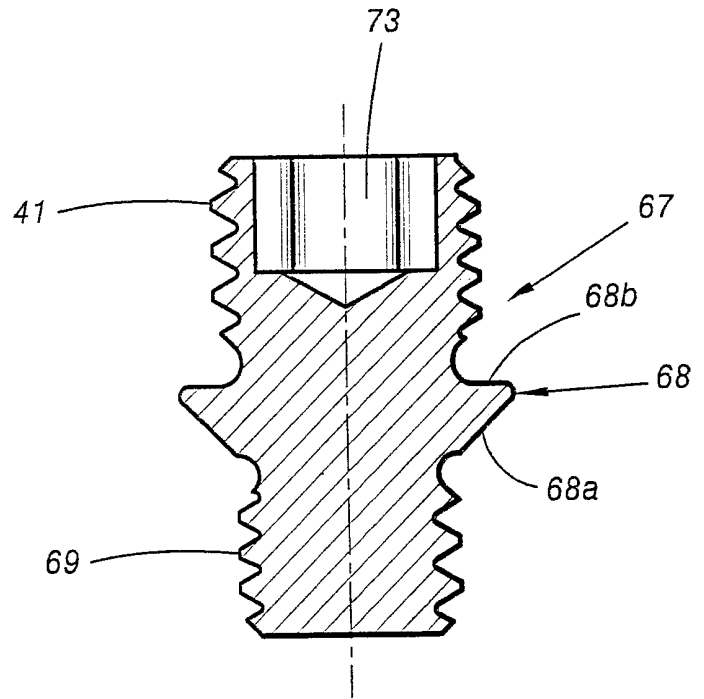

FIG. 16

9/11

FIG.17

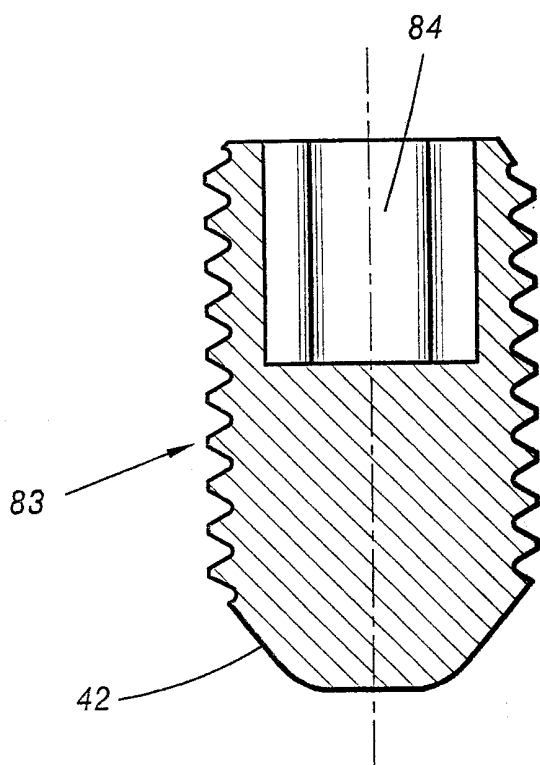
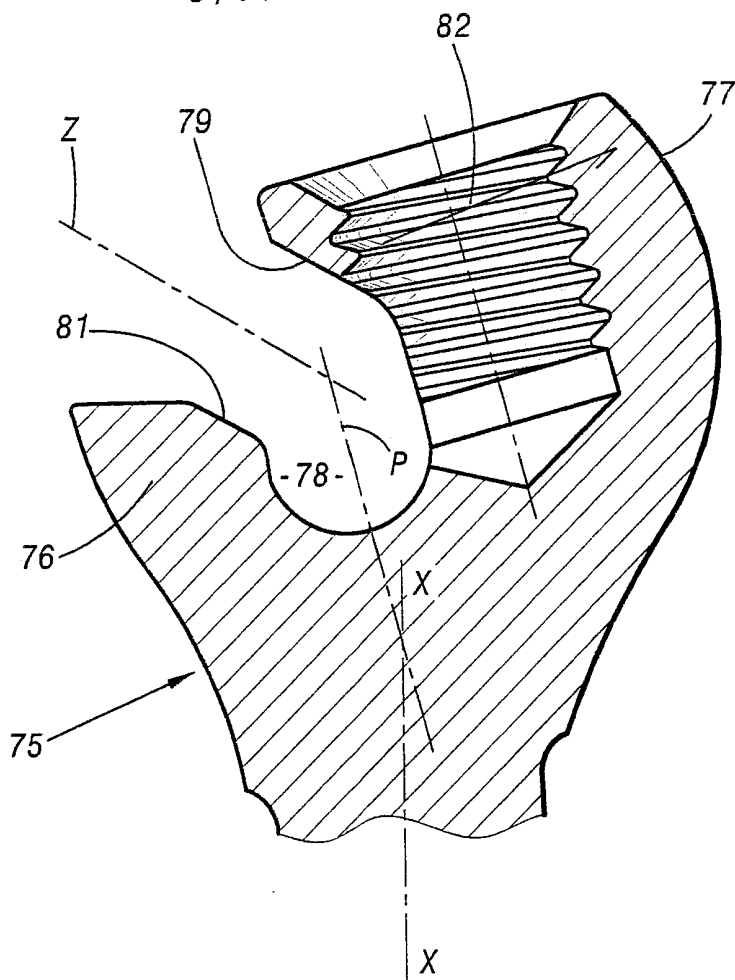

FIG.18

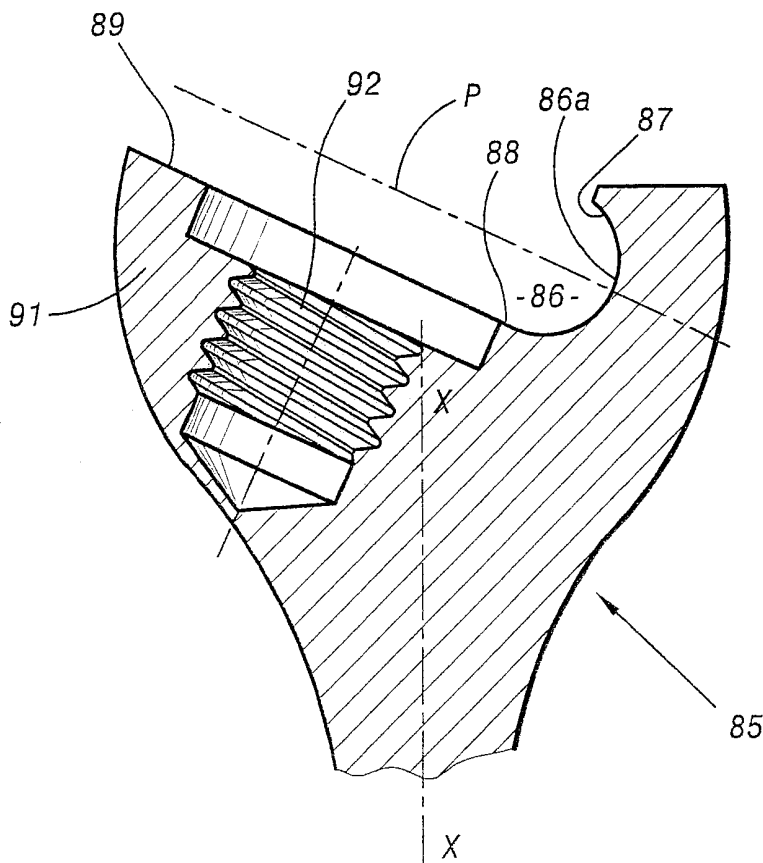
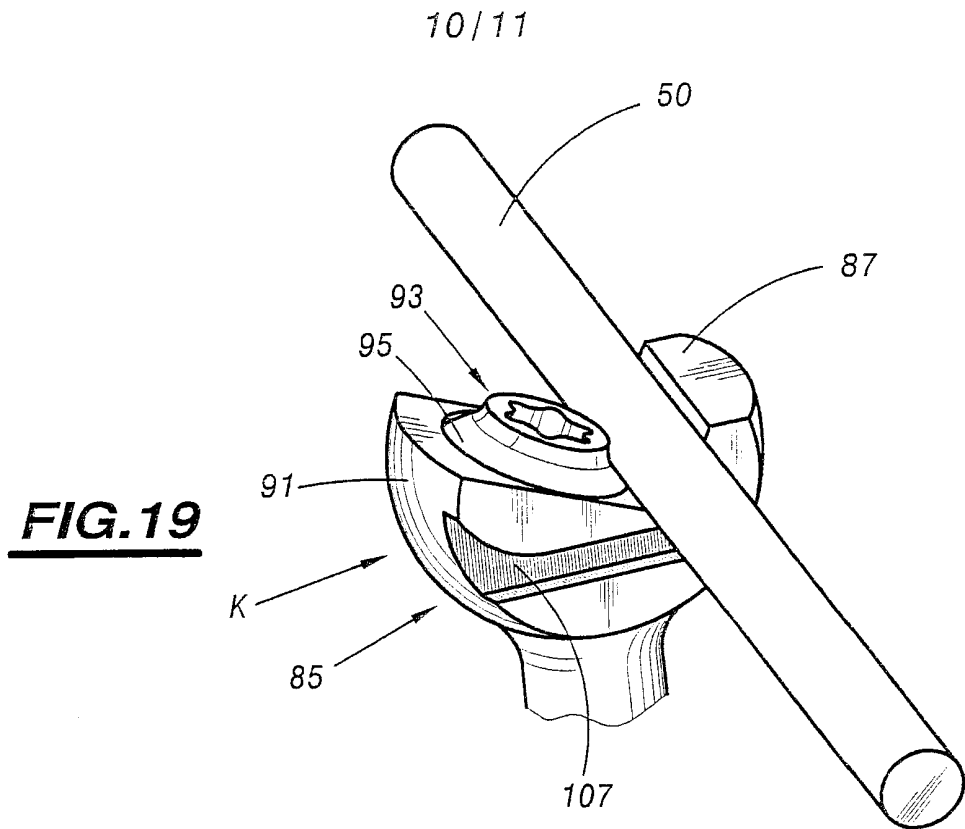

FIG. 20

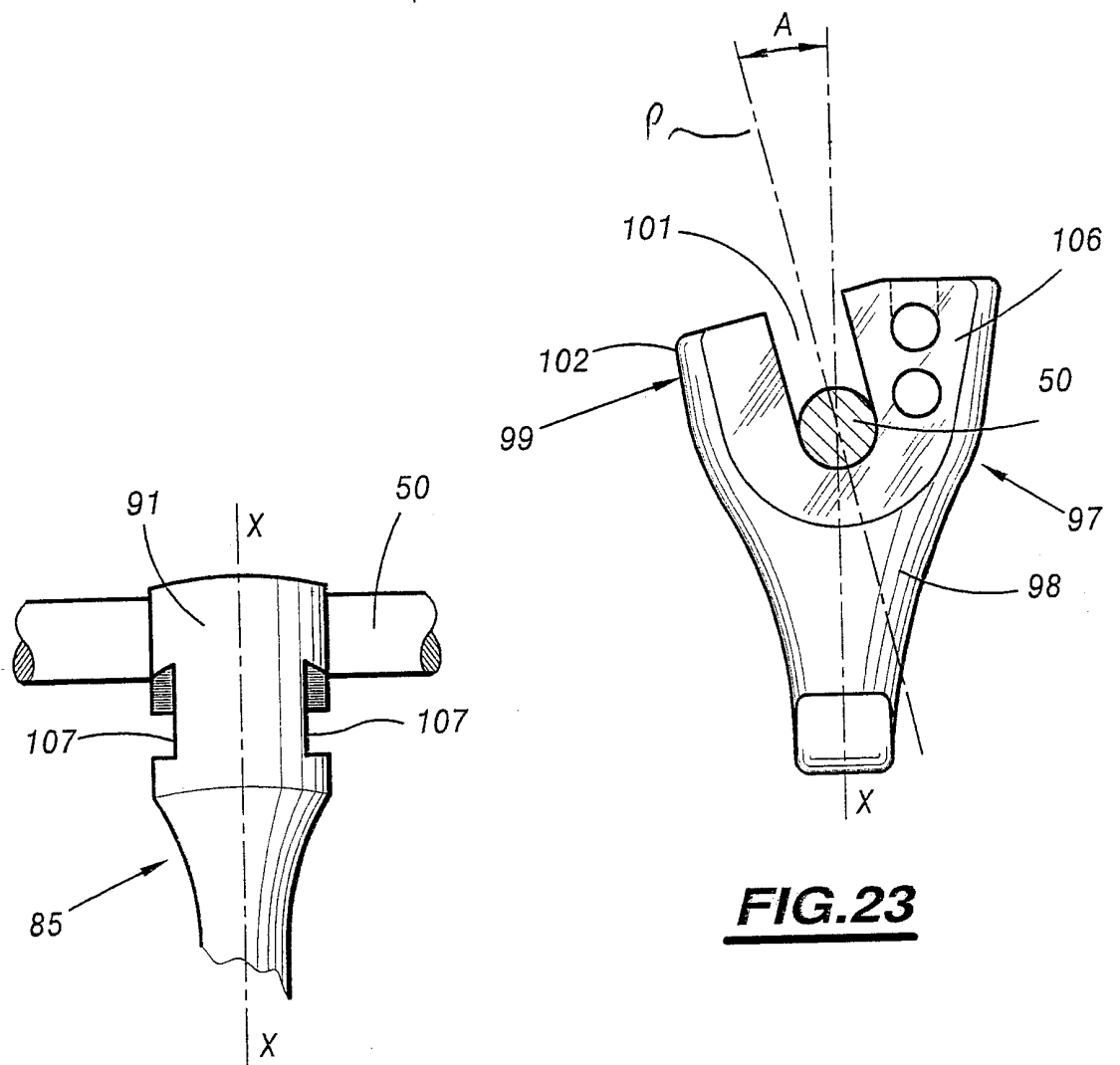
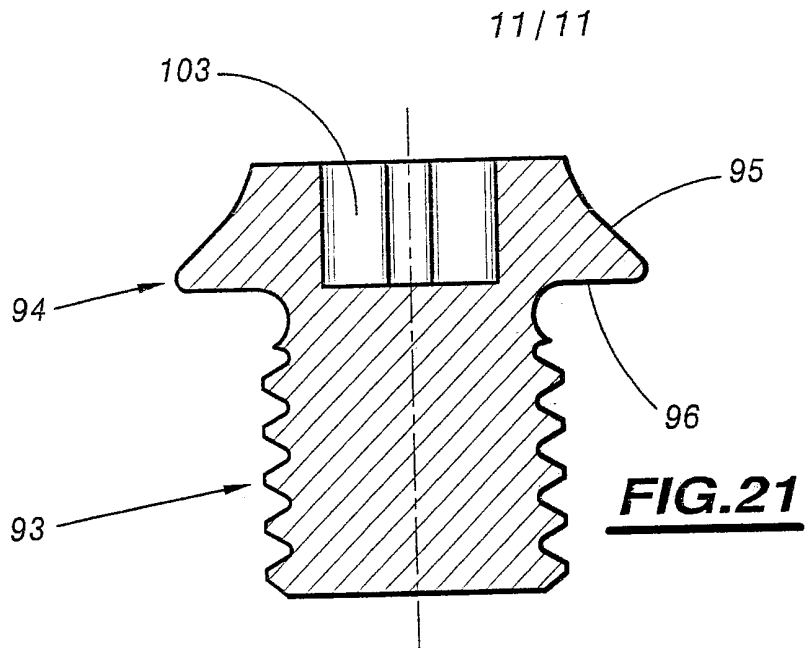

FIG. 22

INTERNATIONAL SEARCH REPORT

International Application No

PCT/IB 00/01956

A. CLASSIFICATION OF SUBJECT MATTER

IPC 7 A61B17/70

According to International Patent Classification (IPC) or to both national classification and IPC

B. FIELDS SEARCHED

Minimum documentation searched (classification system followed by classification symbols)

IPC 7 A61B

Documentation searched other than minimum documentation to the extent that such documents are included in the fields searched

Electronic data base consulted during the international search (name of data base and, where practical, search terms used)

EPO-Internal, PAJ

C. DOCUMENTS CONSIDERED TO BE RELEVANT

| Category ° | Citation of document, with indication, where appropriate, of the relevant passages | Relevant to claim No. |
|------------|---|--------------------------------|
| X A | PATENT ABSTRACTS OF JAPAN vol. 98, no. 6, 30 April 1998 (1998-04-30) & JP 10 052440 A (H.HITODO), 24 February 1998 (1998-02-24) abstract; figures 2,4 | 14-17 1-3,5-8, 11,13 |
| X A | --- EP 0 283 373 A (SOCIETE DE FABRICATION DE MATERIEL ORTHOPEDIQUE) 21 September 1988 (1988-09-21) figure 4 | 14-17 1-3,5-8, 11 |
| X A | --- EP 0 392 927 A (SOCIETE DE FABRICATION DE MATERIEL ORTHOPEDIQUE) 17 October 1990 (1990-10-17) figure 4 | 14-17 1-3,5-8, 11 |
| | --- -/-- | |

Further documents are listed in the continuation of box C.

Patent family members are listed in annex.

° Special categories of cited documents :

- *A* document defining the general state of the art which is not considered to be of particular relevance
- *E* earlier document but published on or after the international filing date
- *L* document which may throw doubts on priority claim(s) or which is cited to establish the publication date of another citation or other special reason (as specified)
- *O* document referring to an oral disclosure, use, exhibition or other means
- *P* document published prior to the international filing date but later than the priority date claimed

- *T* later document published after the international filing date or priority date and not in conflict with the application but cited to understand the principle or theory underlying the invention
- *X* document of particular relevance; the claimed invention cannot be considered novel or cannot be considered to involve an inventive step when the document is taken alone
- *Y* document of particular relevance; the claimed invention cannot be considered to involve an inventive step when the document is combined with one or more other such documents, such combination being obvious to a person skilled in the art.
- *&* document member of the same patent family

Date of the actual completion of the international search

19 March 2001

Date of mailing of the international search report

26/03/2001

Name and mailing address of the ISA

European Patent Office, P.B. 5818 Patentlaan 2
NL - 2280 HV Rijswijk
Tel. (+31-70) 340-2040, Tx. 31 651 epo nl,
Fax: (+31-70) 340-3016

Authorized officer

Nice, P

INTERNATIONAL SEARCH REPORT

International Application No

PCT/IB 00/01956

C.(Continuation) DOCUMENTS CONSIDERED TO BE RELEVANT

| Category ° | Citation of document, with indication, where appropriate, of the relevant passages | Relevant to claim No. |
|------------|---|-----------------------|
| Y | US 5 005 562 A (Y.COTREL) 9 April 1991 (1991-04-09) figure 9 --- | 18 |
| Y | EP 0 472 017 A (A.HÄRLE) 26 February 1992 (1992-02-26) abstract --- | 18 |
| A | FR 2 719 759 A (C.KHALIFE ET S.KHALIFE) 17 November 1995 (1995-11-17) figure 5 ----- | 1,4 |

INTERNATIONAL SEARCH REPORT

International Application No

PCT/IB 00/01956

| Patent document cited in search report | Publication date | Patent family member(s) | Publication date |
|---|---------------------|----------------------------|---------------------|
| JP 10052440 A | 24-02-1998 | JP 2960688 B | 12-10-1999 |
| | | US 6074393 A | 13-06-2000 |
| EP 0283373 A | 21-09-1988 | FR 2612071 A | 16-09-1988 |
| | | AU 599464 B | 19-07-1990 |
| | | AU 1280088 A | 15-09-1988 |
| | | JP 1076847 A | 22-03-1989 |
| EP 0392927 A | 17-10-1990 | FR 2645732 A | 19-10-1990 |
| | | AT 126039 T | 15-08-1995 |
| | | DE 69021428 D | 14-09-1995 |
| | | DE 69021428 T | 25-01-1996 |
| | | DK 392927 T | 11-12-1995 |
| | | ES 2076345 T | 01-11-1995 |
| | | GR 3017386 T | 31-12-1995 |
| | | US 5067955 A | 26-11-1991 |
| | | US 5005562 A | 09-04-1991 |
| DE 8915443 U | 13-06-1990 | | |
| DE 68900228 D | 02-10-1991 | | |
| EP 0348272 A | 27-12-1989 | | |
| ES 2025850 T | 01-04-1992 | | |
| JP 2118789 C | 06-12-1996 | | |
| JP 2198549 A | 07-08-1990 | | |
| JP 8017782 B | 28-02-1996 | | |
| EP 0472017 A | 26-02-1992 | DE 4026777 A | 05-03-1992 |
| | | AT 111713 T | 15-10-1994 |
| | | DE 59103027 D | 27-10-1994 |
| | | ES 2062629 T | 16-12-1994 |
| | | JP 3040547 B | 15-05-2000 |
| | | JP 5076544 A | 30-03-1993 |
| | | US 5643269 A | 01-07-1997 |
| FR 2719759 A | 17-11-1995 | NONE | |