



(72) NAKAMURA, SHUJI, JP
(72) MUKAI, TAKASHI, JP
(72) TANIZAWA, KOJI, JP
(72) MITANI, TOMOTSUGU, JP
(72) MARUI, HIROMITSU, JP
(71) NICHIA CHEMICAL INDUSTRIES, LTD., JP

(51) Int.Cl.⁷ H01L 33/00

(30) 1997/07/25 (9/199471) JP

(30) 1997/09/01 (9/235524) JP

(30) 1997/10/20 (9/286304) JP

(30) 1997/11/06 (9/304328) JP

(30) 1997/11/18 (9/317421) JP

(30) 1997/12/18 (9/348972) JP

(30) 1997/12/18 (9/348973) JP

(30) 1998/06/08 (10/176623) JP

(30) 1998/06/08 (10/176634) JP

(30) 1998/06/29 (10/199829) JP

(54) **DISPOSITIF A SEMI-CONDUCTEUR EN NITRURE**

(54) **NITRIDE SEMICONDUCTOR DEVICE**

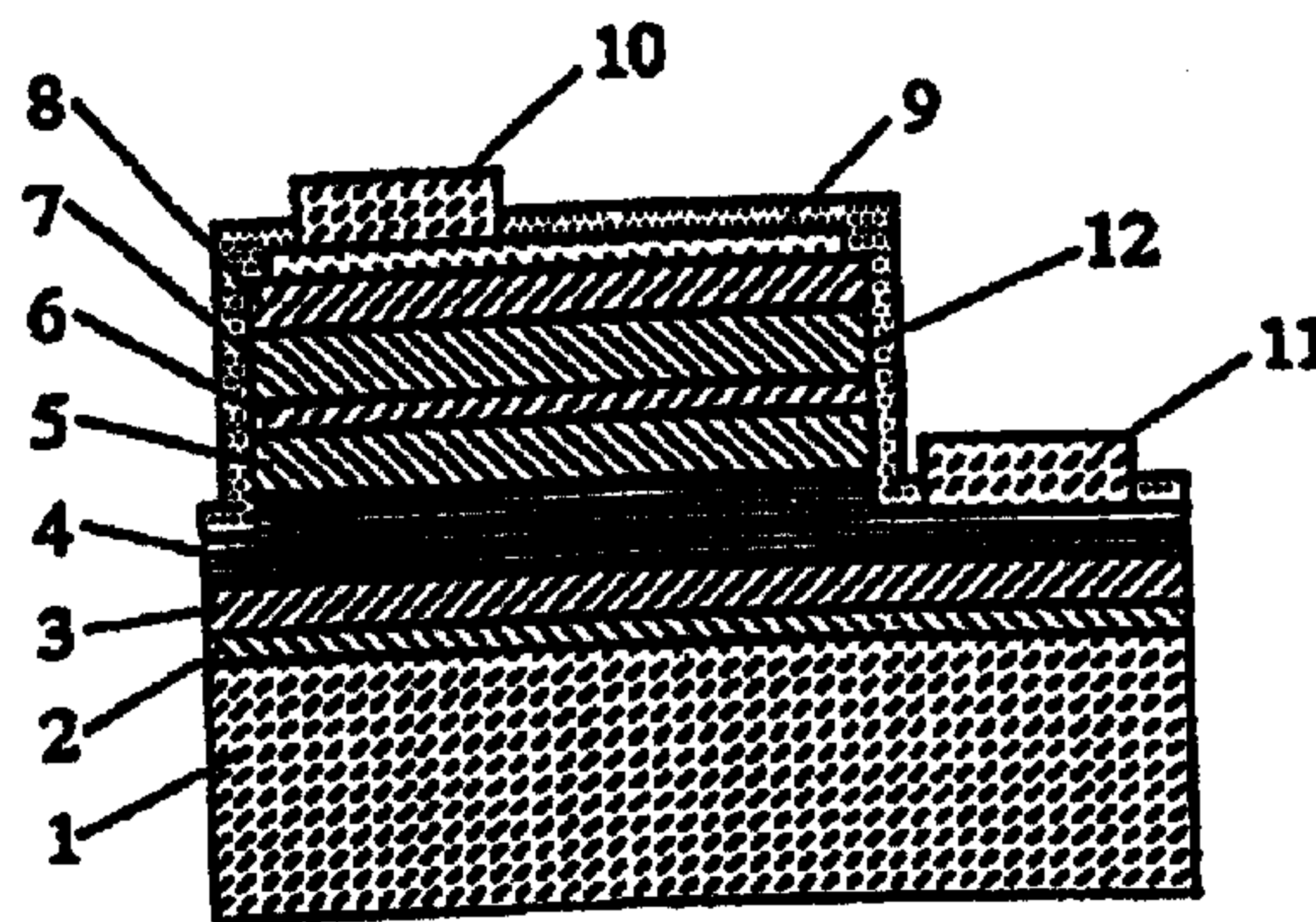

(57) L'invention concerne un dispositif à semi-conducteur en nitrure utilisé surtout comme élément de diode laser et de diode électroluminescente. Afin d'améliorer la sortie et de réduire V_f , on dote le dispositif soit d'une structure à trois couches dans laquelle une couche de semi-conducteur en nitrure dopée avec des impuretés de type n servant de couche de contact de type n dans laquelle une électrode n est formée est placée entre des couches de semi-conducteurs en nitrure non dopées, soit d'une structure à super-réseau en nitrure. La couche de contact de type n présente un concentration de porteurs excédant $3 \times 10^{18} \text{cm}^{-3}$, et sa résistivité peut être inférieure à $8 \times 10^{-3} \Omega \text{cm}$.

(57) A nitride semiconductor device used chiefly as an LD and an LED element. In order to improve the output and to decrease V_f , the device is given either a three-layer structure in which a nitride semiconductor layer doped with n-type impurities serving as an n-type contact layer where an n-electrode is formed is sandwiched between undoped nitride semiconductor layers, or a superlattice structure of nitride. The n-type contact layer has a carrier concentration exceeding $3 \times 10^{18} \text{cm}^{-3}$, and the resistivity can be lowered below $8 \times 10^{-3} \Omega \text{cm}$.



Abstract

A nitride semiconductor device used chiefly as an LD and an LED element. In order to improve the output and to decrease V_f , the device is given either a three-layer structure in which a nitride semiconductor layer doped with n-type impurities serving as an n-type contact layer where an n-electrode is formed is sandwiched between undoped nitride semiconductor layers; or a superlattice structure of nitride. The n-type contact layer has a carrier concentration exceeding $3 \times 10^{18} \text{ cm}^{-3}$, and the resistivity can be lowered below $8 \times 10^{-3} \Omega \text{ cm}$.

Title of the Invention

NITRIDE SEMICONDUCTOR DEVICE

Technical field of the Invention

5 This invention relates to a device provided with a nitride semiconductor ($\text{In}_x\text{Al}_y\text{Ga}_{1-x-y}\text{N}$, $0 \leq x$, $0 \leq y$, $x+y \leq 1$) including light emitting devices such as LED (light emitting diode) and LD (laser diode), solar cells, light receiving devices such as optical sensors and electronic devices such as transistors and power
10 devices.

Background of the Invention

 Nitride semiconductors have been recently produced as materials used for a high bright pure green LED and a blue LED
15 in various light sources for a full color LED display, a traffic signal and an image scanner and the like. These LEDs basically have such a structure that a buffer layer, a n-side contact layer made of Si-doped GaN, an active layer of SQW (Single Quantum Well) made of InGaN or MQW (Multi Quantum Well) including InGaN, a p-side
20 cladding layer made of Mg-doped AlGaN and a p-side contact layer made of Mg-doped GaN are laminated sequentially on the sapphire substrate. Such LEDs show excellent properties and for example, at 20mA, for blue LED having a light emitting wavelength of 450nm, 5mW of output and 9.1% of an external quantum efficiency can be
25 achieved and for green LED having a light emitting wavelength of 520nm, 3mW of output and 6.3% of an external quantum efficiency

can be achieved.

The inventors have first realized laser emitting of 410 nm at room temperature by using the above nitride materials and reported it in Jpn. J. Appl. Phys. 35(1996)L74 and Jpn. J. Appl. Phys. 35(1996)L217. The laser device comprises the DH structure where the active layer is MQW having InGaN well layers and showed the following data:

Threshold current: 610mA;

Threshold current density: 8.7kA/m²;

10 Wavelength: 410 nm

(pulse width 2 μm and pulse cycle 2ms)

The inventors have first succeeded in CW (Continuous-Wave) Oscillation or Operation at room temperature and reported it in Gijutsu-Sokuho of Nikkei Electronics issued on Dec. 2, 1996, Appl. Phys. Lett. 69(1996) and Appl. Phys. Lett. 69(1996) 4056.

The laser diode showed a lifetime of 27 hours at 20°C under the threshold current density of 3.6 kA/cm², the threshold voltage of 5.5 V and the output of 1.5 mW.

Thus, nitride semiconductors have been produced as materials for a LED. And for a LD, continuous-wave oscillation or operation of as long as a few tens hours can be achieved. However, a further enhancement of the output is required in order to use LEDs for illumination lights, outdoor displays exposed to the direct rays of the sun and the like. And it is necessary to improve LDs, in order to decrease the threshold in LDs and realize a longer lifetime of the LDs and to use the LDs in light sources such as the

light-pick-up, DVD and the like. Said LD showed a forward current of 20mA and a forward voltage (Vf) of near 3.6 V. Further decrease of Vf leads to decrease of generation of heat in the device, resulting in increase of reliability. It is extremely important
5 to decrease the threshold voltage in the laser devices to realize a longer lifetime of the devices.

In view of such circumstances, this invention has been accomplished. The main object of the present invention is to enhance the output of the nitride semiconductor devices such as
10 LED and LD and to decrease Vf and the threshold voltage thereof, resulting in the enhancement of the reliability of the devices. Particularly, the first object of the present invention is to increase the carrier concentration in the n-type contact layer and decrease the resistivity thereof.

15 Further, the second object of the present invention is to provide an n-type nitride layer structure in which the carrier concentration in the n-type contact layer is increased and the crystallinity of the nitride semiconductor layer formed on the n-type contact layer can be enhanced.

20 Disclosure of the Invention

According to the present invention, there is provided a nitride semiconductor device comprising an above-mentioned n-type contact layer in a specific three-layer laminated structure or a super lattice structure.

25 According to a first aspect of the present invention, there is provided a nitride semiconductor device, which is a light

emitting device, comprising at least a substrate an n-type contact layer forming an n-electrode, an active layer where electrons and holes are recombined and a p-type contact layer forming a p-electrode, each layer being made of nitride semiconductor, wherein
5 the n-type contact layer is made of a nitride semiconductor doped with an n-type impurity and has a first surface and a second surface, and undoped nitride semiconductor layers are formed close to the first and second surfaces, respectively, resulting in the three-layer laminated structure of the n-type contact layer.

10 In this case, an undoped nitride semiconductor layer means an intentionally not doped layer and includes a nitride semiconductor layer which may contain an impurity originally contained in the raw material, unintentionally introduced by the contamination within the reactor and by diffusion from the other
15 layers which is intentionally doped with an impurity, and also a layer which is considered to be a substantially undoped layer because of doping in a very small amount (for example, resistivity of $3 \times 10^{-1} \Omega \cdot \text{cm}$ or more). An n-type impurity includes Group IV elements such as Si, Ge, Sn and the like and Si is preferred. The
20 nitride semiconductor layers which are laminated therewith, including the n-type contact layer may be made of for example, GaN, InGaN and AlGaN and preferably, the n-type contact layer may be made of GaN including no In or Al in the term of the crystallinity. While the undoped nitride semiconductor layers which are formed
25 on the both sides of the n-type contact layer will be described below in detail. In the case that the n-type contact layer is the

second layer of the three-layer laminated structure, the first nitride semiconductor layer formed on the substrate side thereof may be preferably made of GaN or AlGaN and the nitride semiconductor layer formed on the opposite side of the n-type contact layer to the substrate may be preferably made of GaN, InGaN or AlGaN. Particularly, the representative of the three-layer laminated structure may include the three-layer laminated structure of undoped GaN layer (third layer) / Si-doped GaN layer (second layer) / undoped GaN layer (first layer) in which the n-type contact layer (second layer) doped with Si is sandwiched between the undoped GaN layers.

The second nitride semiconductor layer (n-type contact layer) can have a carrier concentration of not less than $3 \times 10^{18} / \text{cm}^3$ and the resistivity is less than $8 \times 10^{-3} \Omega \cdot \text{cm}$ in the term of the mobility of the layer. The resistivity of the conventional n-type contact layer has been limited to $8 \times 10^{-3} \Omega \cdot \text{cm}$ (for example, US-A 5,733,796). The decrease of the resistivity can lower V_f . The resistivity of $6 \times 10^{-3} \Omega \cdot \text{cm}$ or less can be achieved and more preferably, $4 \times 10^{-3} \Omega \cdot \text{cm}$ or less. The lower limit is not specified and it is desirable to adjust to $1 \times 10^{-5} \Omega \cdot \text{cm}$ or ore. If the resistivity becomes lower than the lower limit, the amount of the impurity becomes too much and the crystallinity of the nitride semiconductor tends to decline.

Moreover, a buffer layer which is grown at a temperature lower than that for the first nitride semiconductor is preferably formed between the substrate and the first nitride semiconductor

layer. The buffer layer may be made by for example, growing AlN, GaN, AlGaN and the like at the temperatures ranging from 400°C to 900°C to the thickness of 0.5 μm or less and acts as a underlying layer for relaxing a lattice mismatch between the substrate and
5 the first nitride semiconductor and growing the first nitride semiconductor layer having a good crystallinity. Particularly, in the case that the first nitride semiconductor layer is made of GaN, the buffer layer may be preferably made of GaN.

Further, the thickness of the third nitride semiconductor
10 layer may preferably be 0.5 μm or less. More preferably, the thickness of the third nitride semiconductor layer may be 0.2 μm or less, most preferably 0.15 μm or less. The lower limit is not specified and it is desirable to adjust to 10 angstroms or more, preferably 50 angstroms or more and most preferably 100
15 angstrom or more. Since the third nitride semiconductor layer is an undoped layer and usually has a high resistivity of 0.1 Ω · cm or more, in the case that the third nitride semiconductor layer is thick, Vf tends not to decrease.

According to a second aspect of the present invention,
20 there is provided a nitride semiconductor device, which is a light emitting device on a substrate, comprising at least an n-type contact layer forming at least an n-electrode on the substrate, an active layer where electrons and holes are recombined and a p-type contact layer forming a p-electrode, each layer being made
25 of nitride semiconductor, wherein the n-type contact layer is a super lattice layer made by laminating at least a nitride

semiconductor doped with an n-type impurity and an undoped nitride semiconductor layer doped with no n-type impurity. Also, as in the case of the first nitride semiconductor device described above, it is preferable that the first and third nitride semiconductor layers are not doped with an n-type impurity or are doped by the concentration of an n-type impurity smaller than that in the super lattice layer and are formed close to the first and second surface of the n-type contact layer, respectively in a manner that the second nitride semiconductor layer (n-type contact layer) is interposed between the first layer and the third one.

In the second nitride semiconductor device, the super lattice structure means a structure made by laminating the nitride semiconductor layers which has a thickness of 100 angstroms or less, more preferably 70 angstroms or less and most preferably 50 angstroms or less in the multi-layered structure. And in this specifications, the super lattice structure or layer includes a type of multi-layered film made by laminating layers which have different constitutions from each other and a type of multi-layered film made by laminating layers which have the same constitutions and different amounts of a n-type impurity from each other. Further, an undoped nitride semiconductor layer means a nitride semiconductor layer which is not intentionally doped with an impurity and has the same meaning as in the case of the above first light emitting device.

Also, in the second nitride semiconductor device, a buffer layer which is grown at a lower temperature than that for the first

nitride semiconductor layer may be formed between the substrate and the first nitride semiconductor layer. The buffer layer may be made by for example, growing AlN, GaN, AlGaN and the like at the temperatures ranging from 400°C to 900°C to the thickness of
5 0.5 μ m or less and acts as a underlying layer for relaxing a lattice mismatch between the substrate and the nitride semiconductor and growing the first nitride semiconductor layer having a good crystallinity.

The second nitride semiconductor layer may be made by
10 laminating two kinds of nitride semiconductor layers which have different band gap energy from each other and may be made by laminating another nitride semiconductor between said two kinds of nitride semiconductor layers.

In this case, said two kinds of nitride semiconductor
15 layers preferably have different concentrations of an n-type impurity doped from each other. Hereinafter, the configuration of the super lattice layer in which the nitride semiconductor layers have different concentrations of an impurity from each other is called modulation doping.

20 Also, in the case that the second nitride semiconductor layer is formed by laminating two kinds of layers which have different band gap energy from each other, the layer having a higher band gap energy may be doped with a n-type impurity in a larger amount or the layer having a lower band gap energy may be doped
25 in a larger amount.

And in the case that the second nitride semiconductor layer

is formed by laminating two kinds of layers which have different band gap energy from each other, one of the layers is preferably is not doped with an impurity, that is, is an undoped layer. In this case, the layer having a higher band gap energy may be doped
5 with an n-type impurity or the layer having a lower band gap energy may be doped.

Further, in the present invention, said second nitride semiconductor layer may be made by laminating two kinds of layers which have the same constitutions except different concentrations
10 of a n-type impurity from each other. In this case, one of the two kinds of nitride semiconductor layers is preferably an undoped layer which is not doped with a n-type impurity.

Particularly, a typical n-type contact layer in a form of a super lattice structure is made by laminating alternately
15 nitride semiconductor layers selected from the combinations of GaN/GaN, InGaN/GaN, AlGaN/GaN and InGaN/AlGaN and either one of the nitride semiconductor layers is preferably doped with Si.

Further, in the case that the third nitride semiconductor layer is provided, it is preferable that the third nitride
20 semiconductor layer is undoped and has a thickness of $0.1\mu\text{m}$ or less. More preferably, the third nitride semiconductor layer has a thickness of 500 angstroms or less, and most preferably, 200 angstroms or less. The lower limit of the thickness the third nitride semiconductor layer is not particularly specified and is
25 desirably controlled to 10 angstroms or more. In the case that the third nitride semiconductor layer is not a super lattice layer,

but an undoped single layer, the resistivity thereof is usually as high as $1 \times 10^{-1} \Omega \cdot \text{cm}$ or more. Therefore, when the third nitride semiconductor layer is grown to the thickness of more than $0.1 \mu\text{m}$, contrarily, V_f tends not to decrease. When the third nitride semiconductor layer is an undoped layer, the nitride semiconductor layer has a good crystallinity and the active layer which is grown thereon also has a good crystallinity, resulting in the good improvement of the output.

The n-type contact layer constituting the super lattice structure can have a carrier concentration of not less than $3 \times 10^{18}/\text{cm}^3$ and considering the mobility of the layer, the resistivity thereof is less than $8 \times 10^{-3} \Omega \cdot \text{cm}$. The resistivity of the prior n-type contact layer is limited to $8 \times 10^{-3} \Omega \cdot \text{cm}$, but the decrease of the resistivity can lead to the decrease of V_f , as in the case of the first nitride semiconductor device. The realizable resistivity is $6 \times 10^{-3} \Omega \cdot \text{cm}$ or less and more preferably, $4 \times 10^{-3} \Omega \cdot \text{cm}$ or less. The lower limit is not particularly specified and desirably controlled to $1 \times 10^{-5} \Omega \cdot \text{cm}$ or more. If the resistivity is below the lower limit, the amount of an impurity is too much and the crystallinity of the nitride semiconductor tends to deteriorate.

Brief Explanation of the Drawing

Fig. 1 is a schematic sectional view of the LED device structure of an embodiment according to the present invention.

Fig. 2 is a schematic sectional view of the LED device structure of another embodiment according to the present

invention.

PREFERRED EMBODIMENT OF THE INVENTION

Embodiment 1

The first light emitting device according to the present
5 invention comprises a nitride semiconductor layer which has an
at least three-layer laminated structure between the active layer
and the substrate. The first nitride semiconductor layer is
undoped, so as to grow a second nitride semiconductor layer which
contains a n-type impurity and has a good crystallinity. If the
10 first nitride semiconductor layer is intentionally doped with an
impurity, the crystallinity thereof deteriorates and it is
difficult to grow a second nitride semiconductor which has a good
crystallinity. Next, the second nitride semiconductor layer is
doped with a n-type impurity and has a low resistivity and a high
15 carrier concentration, to act a contact layer for forming a
n-electrode. Therefore, the resistivity of the second nitride
semiconductor layer is desirably as low as possible to obtain a
good ohmic contact with the n-electrode material and is preferably
less than $8 \times 10^{-3} \Omega \cdot \text{cm}$. Next, the third nitride semiconductor layer
20 is also undoped. This is because the second nitride semiconductor
layer which has a low resistivity and a large carrier concentration
does not have a very good crystallinity. If an active layer,
cladding layer and the like are grown directly on such a second
nitride semiconductor layer, the crystallinity of those layers
25 deteriorates. When the third nitride semiconductor layer which
is undoped and has a good crystallinity is interposed between those

layers, the third nitride semiconductor layer acts as a buffer layer for growing the active layer. Further, when an undoped layer having a relatively high resistivity is interposed between the active layer and the second layer, the leak current of the device
5 can be prevented and the backward withstand voltage can be enhanced. And the second nitride semiconductor layer has a carrier concentration of more than $3 \times 10^{18}/\text{cm}^3$. An n-type impurity include IV group elements and preferably Si or Ge is used, more preferably Si.

10 In the first nitride semiconductor light emitting device, due to the undoped first nitride semiconductor layer between the active layer and the substrate, the second nitride semiconductor layer doped with a n-type impurity can be grown in such a manner that the crystallinity of the second nitride semiconductor is
15 maintained. Therefore, the second nitride semiconductor layer doped with an n-type impurity which has a good crystallinity and a large thickness can be grown. Moreover, the undoped third nitride semiconductor layer acts as an underlying layer having a good crystallinity for the layer to be grown thereon. Therefore,
20 the resistivity of the second nitride semiconductor layer can be reduced and the carrier concentration thereof can be increased, resulting in the realization of the nitride semiconductor device having an extremely high efficiency. Thus, according to the present invention, a light emitting device having a low V_f and
25 threshold can be realized and the heating value of the device can be decreased, with the result that the device having a high

reliability can be provided.

Embodiment 2

The second light emitting device according to the present invention comprises a nitride semiconductor super lattice layer
5 as a n-type contact layer between the active layer and the substrate. This super lattice layer has a first surface and a second surface and comprises a first nitride semiconductor layer which is undoped or has a lower concentration of a n-type impurity than that of the second nitride semiconductor layer on the first surface, so
10 as to grow a super lattice layer having a good crystallinity. The first nitride semiconductor layer is most preferably undoped and may be doped with a n-type impurity in a smaller amount than that in the second nitride semiconductor layer, because the second nitride semiconductor layer is in a super lattice structure. The
15 n-type impurity includes IV group elements and preferably, Si or Ge is used and more preferably, Si.

Next, when the n-type contact layer is in a super lattice structure, each nitride semiconductor layer constituting the super lattice layer has a thickness of not more than the elastic
20 stain limit and therefore, the nitride semiconductor layer having very few crystal defects can be grown. Moreover, the crystal defects developing through the first nitride semiconductor layer from the substrate can be prevented to some extent, the third nitride semiconductor layer having a good crystallinity can be
25 grown on the super lattice layer. What is worthy of mention is that the effect similar to HEMT can be obtained.

This super lattice layer is preferably formed by laminating alternately a nitride semiconductor layer having a higher band gap energy and a nitride semiconductor layer having a band gap energy lower than that of said nitride semiconductor layer having a higher band gap energy, the two layers having different impurity concentrations. Thickness of the nitride semiconductor layer having a higher band gap energy and the nitride semiconductor layer having a lower band gap energy which constitute the super lattice layer is preferably controlled to be within 100 angstroms, more preferably within 70 angstroms and most preferably within a range from 10 to 40 angstroms. If the thickness of the two layers exceeds 100 angstroms, the nitride semiconductor layer having a higher band gap energy and the nitride semiconductor layer having a lower band gap energy become thicker than the elastic strain limit and microscopic cracks or crystal defects tend to develop in the film. While the lower limit of the thickness of the nitride semiconductor layer having a higher band gap energy and the nitride semiconductor layer having a lower band gap energy is not specified and may be of any value as long as it is monoatomic layer or thicker, it is most preferably 10 angstroms or greater. Further, the nitride semiconductor layer having a higher band gap energy is desirably made by growing a nitride semiconductor which includes at least Al, preferably $\text{Al}_x\text{Ga}_{1-x}\text{N}$ ($0 < x \leq 1$). While the nitride semiconductor layer having a lower band gap energy may be anything as long as it is a nitride semiconductor having a band gap energy lower than that of the nitride semiconductor layer having

a higher band gap energy, it is preferably made of a nitride semiconductor of binary mixed crystal or ternary mixed crystal such as $\text{Al}_Y\text{Ga}_{1-Y}\text{N}$ ($0 < Y \leq 1$, $X > Y$) and $\text{In}_Z\text{Ga}_{1-Z}\text{N}$ ($0 \leq Z < 1$) which can be grown easily and provide good quality of crystal. It is particularly
5 preferable that the nitride semiconductor layer having a higher band gap energy is made of $\text{Al}_X\text{Ga}_{1-X}\text{N}$ ($0 < X < 1$) which does not substantially include In or Ga and the nitride semiconductor layer having a lower band gap energy is made of $\text{In}_Z\text{Ga}_{1-Z}\text{N}$ ($0 \leq Z < 1$) which does not substantially include Al. And for the purpose of
10 obtaining super lattice of excellent quality of crystal, the combination of $\text{Al}_X\text{Ga}_{1-X}\text{N}$ ($0 < X \leq 0.3$) with the mixing proportion of Al (value of X) being not more than 0.3 and GaN is most preferable.

When the second nitride semiconductor layer constitute a cladding layer which functions as a light trapping layer and a
15 carrier trapping layer, it must have a band gap energy higher than that of a quantum well layer of the active layer. A nitride semiconductor layer having a higher band gap energy is made of a nitride semiconductor of high mixing proportion of Al. It has been very difficult to grow a crystal of nitride semiconductor of high
20 mixing proportion of Al according to the prior art, because of cracks which are likely to develop in a thick film. In the case of a super lattice layer according to the present invention, however, cracks are made less likely to occur because the crystal is grown to a thickness within the elastic strain limit, even when a single
25 layer constituting the super lattice layer is made with a somewhat high mixing proportion of Al. With this configuration, a layer

having a high mixing proportion of Al can be grown with good quality of crystal and therefore, effects of light trapping and carrier trapping can be enhanced, resulting in reducing the threshold voltage in the laser device and reducing V_f (forward voltage) in the LED device.

Further, it is preferable that n-type impurity concentration is set to be different between the nitride semiconductor layer having a higher band gap energy and the nitride semiconductor layer having a lower band gap energy of the second nitride semiconductor layer. This configuration is the so-called modulation doping. When one layer is made with lower n-type impurity concentration or is preferably undoped with the impurity and the other layer is doped in a higher concentration, this modulation doping is also capable of decreasing the threshold voltage and V_f . This is because the presence of a layer having a low impurity concentration in the super lattice layer increases the mobility in the layer, and coexistence of a layer having a high concentration of impurity makes it possible to form a super lattice layer even when the carrier concentration is high. That is, it is supposed that the coexistence of a layer of low impurity concentration and high mobility and a layer of high impurity concentration and high carrier concentration allows a layer having a high impurity concentration and high mobility to be a cladding layer, thus decreasing the threshold voltage and V_f .

When a nitride semiconductor layer having a high band gap energy is doped with an impurity in a high concentration, the

modulation doping effect is supposed to generate two-dimensional electron gas between a high impurity concentration layer and a low impurity concentration layer, so that the resistivity decreases due to the effect of the two-dimensional electron gas. In a super lattice layer made by laminating a nitride semiconductor layer which is doped with an n-type impurity and has a high band gap energy and an undoped nitride semiconductor layer with a low band gap energy, for example, the barrier layer side is depleted in the hetero-junction interface between the layer which is doped with the n-type impurity and the undoped layer, while electrons (two-dimensional electron gas) accumulate in the vicinity of the interface on the side of the layer having a lower band gap. Since the two-dimensional electron gas is formed on the lower band gap side and therefore the electron movement is not subject to disturbance by the impurity, electron mobility in the super lattice increases and the resistivity decreases. It is supposed that the modulation doping on P side is caused by the effect of the two-dimensional positive hole gas. In the case of p layer, AlGa_N has higher resistivity than that GaN has. Thus it is supposed that, because the resistivity is decreased by doping AlGa_N with p type impurity in a higher concentration, a substantial decrease is caused in the resistivity of the super lattice layer, thereby making it possible to decrease the threshold value when the device is made.

When a nitride semiconductor layer having a low band gap energy is doped with an impurity in a high concentration, such an effect as described bellow is expected to be produced. When the

AlGaN layer and the GaN layer are doped with the same amounts of Mg, for example, acceptor level of Mg becomes deeper and the activation ratio becomes lower in the AlGaN layer. In the GaN layer, on the other hand, acceptor level of Mg becomes less deep and the Mg activation ratio becomes higher than in the AlGaN layer. When doped with Mg in a concentration of $1 \times 10^{20}/\text{cm}^3$, for example, carrier concentration of about $1 \times 10^{18}/\text{cm}^3$ is obtained in GaN, while the concentration obtained in AlGaN is only about $1 \times 10^{17}/\text{cm}^3$. Hence in the present invention, a super lattice layer is made from AlGaN and GaN and the GaN layer from which higher carrier concentration can be expected is doped with greater amount of impurity, thereby forming super lattice of a high carrier concentration. Moreover, because tunnel effect causes the carrier to move through the AlGaN layer of a lower impurity concentration due to the super lattice structure, the carrier is not under substantially no influence of the AlGaN layer, while the AlGaN layer functions also as a cladding layer having a high band gap energy. Therefore, even when the nitride semiconductor layer having a lower band gap energy is doped with a greater amount of impurity, very good effect can be obtained in decreasing the threshold voltage of the laser device or LED device. The above description deals with a case of forming the super lattice layer on p-type layer side, although similar effect can be obtained also when a super lattice layer is formed on the n layer side.

When the nitride semiconductor layer having a higher band gap energy is doped with an n-type impurity in a high concentration,

the amount of doping in the nitride semiconductor layer having a higher band gap energy is preferably controlled within a range from $1 \times 10^{17}/\text{cm}^3$ to $1 \times 10^{20}/\text{cm}^3$, or more preferably within a range from $1 \times 10^{18}/\text{cm}^3$ to $5 \times 10^{19}/\text{cm}^3$. When the impurity concentration is lower than $1 \times 10^{17}/\text{cm}^3$, the difference from the concentration in the nitride semiconductor layer having a lower band gap energy becomes too small to obtain a layer of high carrier concentration. When the impurity concentration is higher than $1 \times 10^{20}/\text{cm}^3$, on the other hand, leak current in the device itself tends to increase.

10 Meanwhile the n-type impurity concentration in the nitride semiconductor layer having a lower band gap energy may be at any level as long as it is lower than that of the nitride semiconductor layer having a higher band gap energy, but it is preferably lower than one tenth of the latter. Most preferably the nitride

15 semiconductor layer having a lower band gap energy is undoped, in which case a layer of the highest mobility can be obtained. However, because each of the component layers of a super lattice layer is thin, some of the n-type impurity diffuses from the nitride semiconductor layer having a higher band gap energy into the nitride

20 semiconductor layer having a lower band gap energy. Therefore, the n-type impurity concentration in the nitride semiconductor layer having a lower band gap energy is preferably $1 \times 10^{19}/\text{cm}^3$ or less. The n-type impurity is selected from among the elements of IVB group and VIB group of the periodic table such as Si, Ge, Se, S and O, and preferably selected from among Si, Ge and S. The effect

25 is the same also in case the nitride semiconductor layer having

a higher band gap energy is doped with less amount of n-type impurity and the nitride semiconductor layer having a lower band gap energy is doped with greater amount of n-type impurity. Although, the above description deals with a case of modulation doping in which
5 the super lattice layer is preferably doped with an impurity, it is also possible that the impurity amount in the nitride semiconductor layer having a higher band gap energy is the same as in the nitride semiconductor layer having a lower band gap energy.

10 In the nitride semiconductor layer constituting the super lattice layer, the layer doped with the impurity in a higher concentration is preferably doped so that such a distribution of impurity concentration is obtained, that the impurity concentration is high in the middle portion of the semiconductor
15 layer in the direction of thickness and is low (or preferably undoped) in the portions near the both ends. When the super lattice layer is formed from the AlGa_N layer doped with Si as n-type impurity and the undoped GaN layer, the AlGa_N layer releases electrons as donor into the conductive band because it is doped with Si and the
20 electrons fall in the conductive band of the GaN which has a low potential. Because the GaN crystal is not doped with the donor impurity, carrier disturbance due to an impurity does not occur. Thus the electrons can move easily in the GaN crystal, namely high electron mobility is obtained. This is similar to the effect of
25 the two-dimensional electron gas described previously, thus increasing the mobility of the electrons substantially in the

transverse direction and decreasing the resistivity. Further, the effect is enhanced when the central region of the AlGa_N layer having a higher band gap energy is doped with the n-type impurity in a high concentration. That is, among the electrons that move in Ga_N,
5 electrons are more or less subject to disturbance by the n-type impurity ions (Si in this case) which are present in AlGa_N. However, when end portions of the AlGa_N layer in the direction of thickness are undoped, electrons become less subject to the disturbance of Si, and therefore mobility in the undoped Ga_N layer is further
10 improved. Similar effect is obtained also when super lattice layer is formed on the p layer side, although the action is different somewhat, and it is preferable that the nitride semiconductor layer having a higher band gap energy is doped with the p-type impurity in a higher concentration at the middle portion thereof and doped
15 in a lower concentration or undoped at both end portions thereof. Although the impurity concentration distribution may also be realized in the nitride semiconductor layer having a lower band gap energy doped with the n-type impurity in a higher concentration, a super lattice layer made by doping the nitride semiconductor layer
20 having a lower band gap energy in a higher concentration tends to have a less effect.

In the device according to the present invention, the third nitride semiconductor layer is also undoped or doped with an n-type impurity in a concentration lower than that in the second nitride
25 semiconductor layer. If the third nitride semiconductor layer containing a large amount of impurity is grown directly on the top

layer of the super lattice layer, the crystallinity of the third nitride semiconductor layer tends to deteriorate. Therefore, the third nitride semiconductor layer is doped with an n-type impurity in a low concentration and most preferably undoped, so as to grow the third nitride semiconductor layer having a good crystallinity. The composition of the third nitride semiconductor layer is not matter of importance. But the third nitride semiconductor layer is preferably made of $\text{In}_x\text{Ga}_{1-x}\text{N}$ ($0 \leq x \leq 1$), more preferably $\text{In}_x\text{Ga}_{1-x}\text{N}$ ($0 < x \leq 0.5$) and in such a case, the third nitride semiconductor layer acts as a buffer layer for the layers to be grown thereon, with the result that the layers above the third nitride semiconductor layer can be easily grown. Further, when the layer having a relatively high resistivity such as an undoped single layer is interposed between the active layer and the second layer, the leak current in the device can be prevented and the backward withstand voltage can be enhanced.

Example 1

Super lattice structure LED

Undoped GaN//Si doped GaN (B)/undoped GaN (A)//undoped GaN

Fig.1 is a schematic sectional view of the LED structure of one example according to the second embodiment of the present invention. The method of manufacturing the device of the present invention will be described in conjunction with this drawing.

A C-plane sapphire substrate 1 is set in the reactor and the inside atmosphere of the reactor is fully replaced with hydrogen. The temperature of the substrate is increased to 1050 °C

with hydrogen being flown in order to clean the substrate. As the substrate 1, in addition to C-plane sapphire substrate, the insulating substrate such as R- or A-plane sapphire substrate and the spinel ($MgAl_2O_4$) substrate and the semiconductor substrate such as SiC (including 6H, 4H 3C), Si, ZnO, GaAs, GaN and the like may be used.

(buffer layer 2)

Subsequently, the temperature is decreased to $510^\circ C$. A buffer layer 2 made of GaN having a thickness of about 200 angstroms is grown using ammonia and TMG (trimethylgallium) as a source of GaN.

(first nitride semiconductor layer 3)

After growing the buffer layer 2, only TMG is stopped and the temperature is increased to $1050^\circ C$. At $1050^\circ C$, in the same way using ammonia and TMG as a source of GaN, a first nitride semiconductor layer 3 made of undoped GaN was grown to the thickness of $5 \mu m$. The first nitride semiconductor layer is grown at a temperature higher than that in the case of the buffer layer, for example, at $900^\circ C$ to $1100^\circ C$. The first nitride semiconductor layer 3 can be made of $In_xAl_yGa_{1-x-y}N$ ($0 \leq x, 0 \leq y, x+y \leq 1$) and the composition thereof is not a matter of importance. But preferably, the first nitride semiconductor layer is made of GaN or $Al_xGa_{1-x}N$ with X being not more than 0.2, with the result that the nitride semiconductor layer having a less crystal defects can be easily obtained. The thickness of the first nitride semiconductor layer is not a matter of importance and is larger than that of buffer layer, usually being

not less than $0.1 \mu\text{m}$. Since this layer is an undoped layer, it is similar to the intrinsic semiconductor and has a resistivity of larger than $0.2 \Omega \cdot \text{cm}$. The resistivity of the first nitride semiconductor layer may be decreased by doping an n-type impurity
 5 such as Si and Ge in a less amount than that in the second nitride semiconductor layer.

(second nitride semiconductor layer 4)

Subsequently, at 1050°C , an undoped GaN layer having a thickness of 20 angstroms is grown using TMG and ammonia gas. Next,
 10 at the same temperature, silane gas is added and a GaN layer doped with Si to $1 \times 10^{19}/\text{cm}^3$ is grown to the thickness of 20 angstroms. Thus, a pair of A layer made of undoped GaN layer having a thickness of 20 angstroms and B layer made of Si-doped GaN having a thickness of 20 angstroms is grown. The pair is laminated in 250 layers,
 15 resulting in a second nitride semiconductor layer 4 in the form of super lattice structure having a thickness of $1 \mu\text{m}$.

(third nitride semiconductor layer 5)

Next, only silane gas is stopped and at 1050°C , in the same way, a third nitride semiconductor layer 5 made of undoped GaN is
 20 grown to the thickness of 100 angstroms. The third nitride semiconductor layer 5 can be made of $\text{In}_x\text{Al}_y\text{Ga}_{1-x-y}\text{N}$ ($0 \leq x, 0 \leq y, x+y \leq 1$) and the composition thereof is not a matter of importance. But preferably, the third nitride semiconductor layer is made of GaN, $\text{Al}_x\text{Ga}_{1-x}\text{N}$ with X being not more than 0.2 or $\text{In}_y\text{Ga}_{1-y}\text{N}$ with Y being
 25 not more than 0.1, with the result that the nitride semiconductor layer having less crystal defects can be easily obtained. In the

case of that the layer made of InGaN is grown, when the nitride semiconductor layer including Al is grown thereon, cracks are prevented from developing into the nitride semiconductor layer including Al.

5 (active layer 6)

Next, the temperature is decreased to 800°C and the carrier gas is changed into nitrogen. An undoped $\text{In}_{0.4}\text{Ga}_{0.6}\text{N}$ layer having a thickness of 30 angstroms is grown, using TMG, TMI (trimethylindium) and ammonia to form an active layer 6 having a
10 single quantum well structure. This layer may have a multiple quantum well structure made of InGaN.

(p-side cladding layer 7)

Next, the temperature is increased to 1050°C and using TMG, TMA, ammonia and Cp2Mg (cyclopentadienyl magnesium), a p-side
15 cladding layer 7 made of p-type $\text{Al}_{0.1}\text{Ga}_{0.9}\text{N}$ doped Mg to $1 \times 10^{20}/\text{cm}^3$ is grown to the thickness of 0.1 μm . This layer functions as a carrier trapping layer. This layer is desirably made of a nitride semiconductor containing Al, preferably $\text{Al}_Y\text{Ga}_{1-Y}\text{N}$ ($0 < Y < 1$). It is desirable to grow a $\text{Al}_Y\text{Ga}_{1-Y}\text{N}$ layer with Y being not more than 0.3
20 to a thickness of not more than 0.5 μm , so as to obtain a layer having a good crystallinity.

And the p-side cladding layer 7 may be a super lattice layer. When a super lattice layer is in the p-side layer region, the thresholds are further decreased and a good result is obtained.
25 Any layer in the p-side layer region may be a super lattice layer.

(p-side contact layer 8)

Subsequently, at 1050°C, using TMG, ammonia and Cp2Mg, a p-side contact layer 8 made of p-type GaN doped with Mg to $1 \times 10^{20}/\text{cm}^3$ is grown to the thickness of 0.1 μm . The p-side contact layer 8 also can be made of $\text{In}_x\text{Al}_y\text{Ga}_{1-x-y}\text{N}$ ($0 \leq X$, $0 \leq Y$, $X+Y \leq 1$) and the
5 composition thereof is not a matter of importance. But preferably, the p-side contact layer is made of GaN, with the result that the nitride semiconductor layer having less crystal defects can be easily obtained and a preferable ohmic contact with the p electrode material can be achieved.

10 After the reaction is completed, the temperature is decreased to room temperature. Additionally, annealing is performed to the wafer at 700°C in nitrogen atmosphere within the reactor, so as to make the p-type layers less resistive.

After annealing, the wafer is removed out of the reactor.
15 A mask of a predetermined shape is formed on the top surface of the p-side contact layer which is an uppermost layer and etching is conducted from the p-side contact layer side with RIE (reactive ion etching) apparatus, to expose the surface of the second nitride semiconductor layer 4, as shown in Fig.1.

20 After etching, a transparent p-electrode 9 containing Ni and Au and having a thickness of 200 angstroms is formed on the almost entire surface of the uppermost p-side contact layer and a p-pad electrode 10 made of Au for bonding is formed on the p-electrode 9. Meanwhile, a n-electrode 11 containing W and Al
25 is formed on the surface of the second nitride semiconductor layer 4 which has been exposed by etching. Finally, an insulating film

12 made of SiO₂ is formed to protect the surface of the p-electrode 9, as shown in Fig. 1. Then the wafer is scribed and cleaved into LED devices which are 350 μm by 350 μm square.

For this LED device, pure green light emission of 520nm
 5 was obtained at a forward voltage of 20mA. Vf was decreased by 0.2 to 0.4 V and the output was enhanced by 40 to 50% at 20mA, as compared with the conventional green light emitting LED made by laminating on the substrate a buffer layer made of GaN, n-side contact layer made of Si doped GaN, an active layer made of InGaN
 10 in the form of a single quantum well structure, a p-side cladding layer made of Mg doped AlGaN and a p-side contact layer made of Mg doped GaN sequentially. The static withstand voltage was higher than that of the conventional LED by 5 times or more.

Example 2

15 LED in the form of a super lattice structure

Si doped GaN//Si-doped GaN (B)/undoped GaN (A)//Si doped GaN

With the same procedures as in Example 1, the first nitride semiconductor layer 3 is made by growing GaN doped with Si to $1 \times 10^{19}/\text{cm}^3$ to the thickness of 3 μm and the third nitride
 20 semiconductor layer 5 is made by growing GaN doped with Si to $1 \times 10^{17}/\text{cm}^3$. The other constructions of the LED device were the same as in Example 1. Compared with the LED device in Example 1, the output was decreased by about 10% and Vf and static withstand voltage were almost the same.

25 Example 3

LED in the form of a super lattice structure

Undoped GaN//Si doped GaN/undoped InGaN//undoped GaN

The LED device was fabricated in the same manner as in Example 1, except that the second nitride semiconductor was formed as follows.

5 That is, at 1050 °C, using TMG, ammonia gas and Si gas, a GaN layer doped with Si to $1 \times 10^{19}/\text{cm}^3$ which has a thickness of 25 angstroms is grown. Subsequently, at 800 °C, using TMI, TMG and ammonia gas, an undoped InGaN layer having a thickness of 75 μ m is grown. In this way, A layer made of Si doped GaN layer having
10 a thickness of 25 angstroms and B layer made of undoped InGaN layer having a thickness of 75 angstroms are laminated alternately in 100 layers, respectively, resulting in the second nitride semiconductor layer in the form of a super lattice structure having a total thickness of 2 μ m.

15 The LED in the form of a super lattice structure Of Example 3 had almost similar properties to those of Example 1.

Example 4

LED in the form of a super lattice structure

Undoped GaN//Si doped AlGa_{0.1}N/undoped GaN//undoped GaN

20 With the same procedure as in Example 1, the second nitride semiconductor layer 4 is made by laminating alternately A layer made of undoped GaN layer having a thickness of 40 angstrom and B layer made of Al_{0.1}Ga_{0.9}N layer doped Si to $1 \times 10^{18}/\text{cm}^3$ evenly which has a thickness of 60 angstroms, in 300 layers, respectively,
25 resulting in a super lattice structure having a total thickness of 3 μ m. Other constructions of the LED device are the same as

in Example 1. The LED had almost similar properties to those of Example 5

LD in the form of a super lattice structure

Undoped InGaN//Si doped GaN (B)/undoped GaN (A)//undoped GaN

5 Fig. 2 is a schematic sectional view showing the structure of the laser device according to another example of the present invention. In this drawing, the device which is cut in the parallel direction to the resonating plane of the emission is shown. Example 5 will be described with reference to Fig. 2.

10 With the same procedure as in Example 1, on the C-plane sapphire substrate, a buffer layer 21 made of GaN having a thickness of 200 angstroms, a first nitride semiconductor layer 22 made of undoped GaN having a thickness of $5 \mu\text{m}$, a second nitride semiconductor layer 23 in the form of a super lattice structure
15 having a total thickness of $3 \mu\text{m}$ made by laminating A layer made of undoped GaN layer having a thickness of 20 angstrom and B layer made of Si doped GaN having a thickness of 20 angstroms are grown (the second nitride semiconductor layer 4 has the same construction as that of Example 1).

20 Other substrate than the sapphire may be used. On the substrate made of other materials than nitride semiconductor like sapphire, a first GaN layer is grown. A protective film on which a nitride semiconductor such as SiO_2 cannot be easily grown is formed partially on the first GaN layer. A second nitride semiconductor
25 layer is grown on the first nitride semiconductor layer via the protective film and thus, the second nitride semiconductor layer

is grown in the transverse direction on SiO_2 . The second nitride semiconductor layer links with each other in the transverse direction. The second nitride semiconductor layer obtained in this way is most preferably used as a substrate, so as to achieve
5 a good crystallinity of the nitride semiconductor. When this nitride semiconductor substrate is used as a substrate, the buffer layer is not needed to be grown.

(third nitride semiconductor layer 24)

At 800°C , using TMI, TMG and ammonia, a third nitride
10 semiconductor layer made of undoped $\text{In}_{0.05}\text{Ga}_{0.95}\text{N}$ is grown to the thickness of 500 angstroms.

(n-side cladding layer 25)

Next, at 1050°C , a n-type $\text{Al}_{0.2}\text{Ga}_{0.8}\text{N}$ layer doped with Si to $1 \times 10^{19}/\text{cm}^3$ which has a thickness of 20 angstroms and an undoped
15 GaN layer having a thickness of 20 angstroms are laminated alternately, in 200 layers, resulting in a super lattice structure having a total thickness of $0.8 \mu\text{m}$. The n-side cladding layer 254 functions as a carrier trapping layer and light trapping layer and is preferably made of a nitride semiconductor containing Al, more
20 preferably AlGaN. The total thickness of the super lattice layer is preferably controlled within the range of from 100 angstroms to $2 \mu\text{m}$, more preferably within the range of from 500 angstroms to $2 \mu\text{m}$. Moreover, the concentration of an impurity is high in the middle portion of the n-side cladding layer and low in both end
25 portions thereof.

(n-side optical waveguide layer 26)

Subsequently, an n-side optical guide layer 26 made of n-type GaN doped with Si to $1 \times 10^{17}/\text{cm}^3$ is grown to the thickness of $0.1 \mu\text{m}$. This n-side optical waveguide layer functions as an optical waveguide layer for the active layer and is desirably made of GaN and InGaN. The thickness of the n-side optical waveguide layer is usually not more than $5 \mu\text{m}$, preferably 200 angstroms to $1 \mu\text{m}$. This n-side optical waveguide layer is usually doped with an n-type impurity such as Si and Ge to have a n-type conductivity and particularly, may be undoped.

10 (active layer 27)

Next, at 800°C , an active layer 27 is made by laminating alternately a well layer which is made of undoped $\text{In}_{0.2}\text{Ga}_{0.8}\text{N}$ and has a thickness of 25 angstroms and a barrier layer which is made of undoped $\text{In}_{0.01}\text{Ga}_{0.99}\text{N}$ and has a thickness of 50 angstroms, thereby forming a layer of a multiple quantum well structure (MQW) having a total thickness 175 angstroms.

(p-side cap layer 28)

Next, at 1050°C , a p-side cap layer 28 which has a band gap energy higher than that of the p-side optical waveguide layer 8 and that of the active layer 6 and is made of p-type $\text{Al}_{0.3}\text{Ga}_{0.7}\text{N}$ doped with Mg to $1 \times 10^{20}/\text{cm}^3$ is grown to the thickness of 300 angstroms. The p-side cap layer 28 is doped with a p-type impurity, but the thickness thereof is small and therefore the p-side cap layer may be of i-type wherein carriers are compensated by doping n-type impurity, preferably may be undoped and most preferably may be doped with a p-type impurity. The thickness of the p-side cap

layer 28 is controlled within $0.1 \mu\text{m}$, more preferably within 500 angstroms and most preferably within 300 angstroms. When grown to a thickness greater than $0.1 \mu\text{m}$, cracks tend to develop in the p-side cap layer 28 making it difficult to grow a nitride semiconductor layer of good quality of crystal. In the case of AlGa_YN having a high proportion of Al, the small thickness can make it for LD device to oscillate easily. When Al_YGa_{1-Y}N has Y value of not less than 0.2, the thickness is desirably controlled within 500 angstroms. The lower limit of the thickness of the p-side cap layer 76 is not specified and but the thickness is preferably 10 angstroms or more.

(p-side optical waveguide layer 29)

Next, a p-side optical waveguide layer 29 which has a band gap energy lower than that of the p-side cap layer 28, and is made of p-type GaN doped with Mg to $1 \times 10^{19}/\text{cm}^3$ is grown to a thickness of $0.1 \mu\text{m}$. This layer functions as an optical waveguide layer for the active layer and is desirably made of GaN and InGa_N as in the case of the n-side optical waveguide layer 26. This p-side optical waveguide layer also functions as a buffer layer when the p-side cladding layer 30 is grown. The thickness of the p-side optical waveguide layer is preferably 100 angstroms to $5 \mu\text{m}$, more preferably 200 angstroms to $1 \mu\text{m}$. The p-side optical waveguide layer is usually to doped with a p-type impurity such as Mg to have a p-type conductivity, but may not be doped with an impurity.

(p-side cladding layer 30)

Next, a p-side cladding layer 30 is made by laminating

alternately a p-type $\text{Al}_{0.2}\text{Ga}_{0.2}\text{N}$ layer which is doped with Mg to $1 \times 10^{20}/\text{cm}^3$ and has a thickness of 20 angstroms and a p-type GaN layer which is doped with Mg to $1 \times 10^{19}/\text{cm}^3$ and has a thickness of 20 angstroms, thereby forming a super lattice layer having a total
5 thickness $0.8 \mu\text{m}$. This layer functions as a carrier trapping layer, as in the case of n-side cladding layer 25. Also this layer functions to decrease the resistivity in the p-type layers due to the super lattice structure. The thickness of the p-side cladding layer 30 is not specified and desirably is within the range
10 of from 100 angstroms to $2 \mu\text{m}$, more preferably within the range of from 500 angstroms to $1 \mu\text{m}$. The concentration of an impurity may be high in the middle portion of the p-side cladding layer and low in both end portions thereof.

(p-side contact layer 31)

15 Finally, a p-side contact layer 10 made of p-type GaN doped with Mg to $2 \times 10^{20}/\text{cm}^3$ is grown to the thickness of 150 angstroms. It is advantageous that the thickness of the p-side contact layer is controlled to not more than 500 angstroms, preferably not more than 400 angstroms and not less than 20 angstroms, so as to decrease
20 the resistivity of the p-type layers and decrease the threshold voltage.

After the completion of the reaction, the wafer is annealed at 700°C within the nitrogen atmosphere in the reactor to make the p-type layers less resistive. After annealing, the wafer is
25 removed out of the reactor and as shown in Fig. 2, the p-side contact layer 31 and the p-side cladding layer 30 which are the uppermost

layers are etched with RIE apparatus into a ridge geometry with a stripe width 4 μm .

After the ridge geometry is formed, as shown in Fig. 2, the p-side cladding layer 30 which is exposed on both sides of the ridge stripe is etched to expose the surface of the second nitride semiconductor layer 23 on which the n-electrode is to be formed. The exposed surface is made of a super lattice layer having a large amount of impurity.

Next, the p-electrode 32 made of Ni/Au is formed on the entire surface of the ridge. Next, as shown in Fig. 2, an insulating film 35 made of SiO_2 is formed on the surface of the p-side cladding layer 30 and the p-side contact layer 31 except for the p-electrode 32. A p-pad electrode 33 which is connected electrically to the p-electrode 32 via the insulating film 35 is formed. Meanwhile, the n-electrode made of W and Al is formed on the surface of the n-side contact layer 4 which has been exposed.

After the electrode is formed, the back surface of the sapphire substrate of the wafer is polished to the thickness of about 50 μm . And then, the wafer is cleaved at the M-plane of sapphire and the bar with the cleaved facet being a resonator plane is fabricated. The bar is scribed and separated parallel to the stripe electrode to fabricate a laser device. The resulting laser device configuration is shown in Fig. 2. When this laser device was oscillated continuously at room temperature, the threshold current density was decreased to about 2.0kA/ cm^2 and the threshold voltage was about 4.0V, compared to the conventional nitride

semiconductor laser device which could oscillate continuously for 37 hours. The lifetime was 500 hours or longer.

Example 6

LED in the form of a super lattice structure

5 Unoped GaN//undoped AlGa_{0.10}N/Si doped GaN//undoped GaN

With the same procedures as in Example 1, the second nitride semiconductor layer 4 is made by laminating a GaN layer which is doped with Si to $1 \times 10^{19}/\text{cm}^3$ and has a thickness of 20 angstroms and an undoped Al_{0.10}Ga_{0.90}N layer having a thickness of 20 angstroms
 10 and growing such a pair in 250 times, thereby forming a super lattice layer having a total thickness of 1.0 μm (10000 angstroms). The other constructions are the same as in Example 1. The similar results were obtained to those in Example 1.

As described above, the nitride semiconductor device
 15 according to the present invention is made by laminating the first nitride semiconductor layer which is undoped or has a small concentration of impurity, the second nitride semiconductor layer of a super lattice layer which has a large concentration of impurity and the third nitride semiconductor layer which is undoped or has
 20 a small concentration of impurity and therefore, the LED which has low V_f and the laser device which has low thresholds can be obtained. Moreover, since the second nitride semiconductor layer has a low resistivity, the ohmic contact can be easily obtained between the n-electrode and the second nitride semiconductor layer and V_f is
 25 decreased. LED and the laser device have been described in this specifications, the present invention can be applied to any device

made of nitride semiconductor such as light receiving devices and solar cells, as well as power devices using the output of the nitride semiconductor.

Example 7

- 5 LED in the form of a three layer laminated structure
Undoped GaN//Si doped n-type GaN//undoped GaN

This LED is fabricated in the same manner as in Example 1, as shown in Fig. 1, an example of LED device of the first embodiment according to the present invention, except that the
10 n-type contact layer is made in the form of the three layer laminated structure. Therefore, only the n-type contact layer of the three layer laminated structure will be described.

(first nitride semiconductor layer 3)

In the same manner as in Example 1, after the growth of
15 the buffer layer 2, only TMG is stopped and the temperature is increased to 1050°C. At 1050°C, using TMG and ammonia gas as source gas, a first nitride semiconductor layer 3 made of undoped GaN is grown to the thickness of 1.5 μm. The first nitride semiconductor layer is grown at a temperature higher than that in the case of
20 the buffer layer, for example, at 90 to 1100 °C. The composition of the first nitride semiconductor layer is not a matter of importance, but preferably is made of Al_xGa_{1-x}N with X being not more than 0.2, with the result that the nitride semiconductor layer having less crystal defects can be easily obtained. The thickness
25 thereof is not a matter of importance, but is larger than that of the buffer layer and usually is within the range of from 0.1 to

20 μm . Since this layer is an undoped layer, it is similar to the intrinsic semiconductor and has a resistivity of larger than 0.1 $\Omega \cdot \text{cm}$. Since the first nitride semiconductor layer is grown at a temperature higher than that in the case of the buffer layer, 5 this layer is undoped, although this layer is different from said buffer layer.

(second nitride semiconductor layer 4)

Subsequently, at 1050°C, using TMG and ammonia gas and silane gas as an impurity, a Si doped GaN layer is grown to the 10 thickness of 3 μm . The second nitride semiconductor layer 3 can be made of $\text{In}_x\text{Al}_y\text{Ga}_{1-x-y}\text{N}$ ($0 \leq X$, $0 \leq Y$, $X+Y \leq 1$) and the composition thereof is not a matter of importance, preferably GaN, $\text{Al}_x\text{Ga}_{1-x}\text{N}$ with X being not more than 0.2 or $\text{In}_y\text{Ga}_{1-y}\text{N}$ with Y being not more than 0.1, with the result that the nitride semiconductor layer having 15 less crystal defects can be easily obtained. The thickness of the second nitride semiconductor layer is not a matter of importance and preferably is within the range of from 0.1 to 20 μm , because the n-electrode is formed thereon. In the case that using the other sapphire substrate which was not in the device structure, the 20 nitride semiconductor layers were grown to a GaN layer in the same manner, the carrier density was $1 \times 10^{19}/\text{cm}^3$ and the resistivity was $5 \times 10^{-3} \Omega \cdot \text{cm}$.

(third nitride semiconductor layer 5)

Next, silane gas is stopped and at 1050°C, a third nitride 25 semiconductor layer 5 made of undoped GaN is grown to the thickness of 0.15 μm , in the same manner. The third nitride semiconductor

layer 5 can also be made of $\text{In}_x\text{Al}_y\text{Ga}_{1-y}\text{N}$ ($0 \leq X, 0 \leq Y, X+Y \leq 1$) and the composition thereof is not a matter of importance, preferably GaN, $\text{Al}_x\text{Ga}_{1-x}\text{N}$ with X being not more than 0.2 or $\text{In}_y\text{Ga}_{1-y}\text{N}$ with Y being not more than 0.1, with the result that the nitride semiconductor layer having less crystal defects can be easily obtained. When InGaN is grown and on said InGaN layer, the nitride semiconductor layer containing Al is grown, the cracks can be prevented from developing in the nitride semiconductor layer containing Al. When the second nitride semiconductor is made of a single nitride semiconductor, it is desirable that the first, second and third nitride semiconductor layers are made of a nitride semiconductor having the same composition, particularly GaN.

The resulting LED device emitted pure green light of 520 nm at the forward voltage of 20mA. At 20mA, V_f was decreased by 0.1 to 0.2V and the output was enhanced by 5 to 10%, compared with the conventional LED emitting green light which was made by laminating sequentially on a sapphire substrate, a buffer layer made of GaN, an n-side contact layer made of Si doped GaN, an active layer made of InGaN in the form of a single quantum well structure, a p-side cladding layer made of Mg doped AlGaN and a p-side contact layer made of Mg doped GaN.

Example 8

Undoped $\text{In}_{0.05}\text{Ga}_{0.95}\text{N}$ //Si doped n-type GaN//undoped GaN

The LD device is fabricated in the same manner as in Example 5 as shown in Fig.2 (showing the device cut in the parallel direction to the resonating plane of the laser), an example of LD device

according to the first embodiment of the present invention, except for the n-type contact layer.

With the same procedures as in Example 1, the buffer layer 21 which is made of GaN and has a thickness of 200 angstroms is grown on the C-plane sapphire substrate 20. And then, the temperature is increased to 1020°C and at 1020 °C, a first nitride semiconductor layer 22 made of undoped GaN is grown to the thickness of 5 μm.

Subsequently, at 1020°C, using silane gas as an impurity gas, a second nitride semiconductor layer 23 made of Si doped n-type GaN is grown. The resistivity of the resulting LD device was also $5 \times 10^{-3} \Omega \cdot \text{cm}$.

(third nitride semiconductor layer 24)

Next, at 800°C, using TMI, TMG and ammonia, a third nitride semiconductor layer made of undoped $\text{In}_{0.05}\text{Ga}_{0.95}\text{N}$ is grown to the thickness of 500 angstroms.

(n-side cladding layer 25)

Next, at 1020°C, a n-side cladding layer is made by laminating alternately an n-type $\text{Al}_{0.2}\text{Ga}_{0.8}\text{N}$ layer which is doped with Si to $1 \times 10^{17}/\text{cm}^3$ and has a thickness of 40 angstroms and an undoped GaN layer having a thickness of 40 angstroms, in 40 layers, thereby forming a super lattice structure. This n-side cladding layer functions as a carrier trapping and light trapping layer.

(n-side optical waveguide layer 26)

Subsequently, a n-side optical waveguide layer 26 made of n-type GaN doped with Si to $1 \times 10^{19}/\text{cm}^3$ is grown to the thickness

of $0.2 \mu\text{m}$. This n-side optical waveguide layer 26 acts as an optical waveguide layer for the active layer and preferably is made of GaN or InGaN. The thickness of the n-side optical waveguide layer is usually within the range of from 100 angstroms to $5 \mu\text{m}$ and preferably within the range of 200 angstroms to $1 \mu\text{m}$. This n-side optical waveguide layer 5 may be undoped.

(active layer)

Next, at 800°C , an well layer made of Si doped $\text{In}_{0.2}\text{Ga}_{0.8}\text{N}$ is grown to the thickness of 25 angstroms. Next, the molar ratio of TMI is changed and a barrier layer made of Si doped $\text{In}_{0.01}\text{Ga}_{0.99}\text{N}$ is grown to the thickness of 50 angstroms. This operation is repeated two times and finally, the well layer is laminated, resulting in a multiple quantum well structure (MQW).

(p-side capping layer 28)

Next, at 1020°C , using TMG, TMA, ammonia and $\text{Cp}2\text{Mg}$, a p-side capping layer 28 which has a band gap energy higher than that of the active layer and is made of p-type $\text{Al}_{0.3}\text{Ga}_{0.7}\text{N}$ doped with Mg to $1 \times 10^{20}/\text{cm}^3$ is grown to the thickness of 300 angstroms. The p-side cap layer 28 is doped with a p-type impurity, but the thickness thereof is small and therefore the p-side cap layer may be of i-type wherein carriers are compensated by doping n-type impurity. The thickness of the p-side cap layer 28 is controlled within $0.1 \mu\text{m}$, more preferably within 500 angstroms and most preferably within 300 angstroms. When grown to a thickness of greater than $0.1 \mu\text{m}$, cracks tend to develop in the p-side cap layer 28 making it difficult to grow a nitride semiconductor layer of good quality

of crystal. And carrier cannot pass the energy barrier by tunneling effect. In the case of AlGa_YN having a high proportion of Al, the small thickness can make it for LD device to oscillate easily. For example, in the case of Al_YGa_{1-Y}N with Y being not less than 0.2, the thickness is desirably controlled within 500 angstroms. The lower limit of the thickness of the p-side capping layer 28 is not specified, but the thickness is desirably not less than 10 angstroms as in the case of the laser device of Example 4.

10 (p-side optical waveguide layer 29)

Next, at 1020°C, a p-side optical waveguide layer 29 made of p-type GaN dope with Mg to $1 \times 10^{18}/\text{cm}^3$ is grown to the thickness of 0.2 μm. This layer functions as an optical waveguide layer for the active layer, as in the case of the n-side optical waveguide layer 26. This layer is desirably made of GaN or InGa_N. The thickness is preferably within the range of from 100 angstroms to 5 μm, more preferably within the range of from 200 angstroms to 1 μm. The p-side optical waveguide layer is usually of p-conductivity by doping a p-type impurity such as Mg, but may be not doped with an impurity.

20 (p-side cladding layer 30)

Next, at 1020 °C, a p-side cladding layer 30 is made by laminating alternately a p-type Al_{0.25}Ga_{0.75}N layer which is doped with Mg to $1 \times 10^{20}/\text{cm}^3$ and has a thickness of 40 angstroms and an undoped p-type GaN layer having a thickness of 40 angstroms, in 40 layers, thereby forming a super lattice layer. This layer also

functions as a carrier trapping layer like the n-side cladding layer
25. The resistivity and thresholds of the p-type layers tend to
decrease because of the p-side cladding layer in the form of a super
lattice structure.

5 (p-side contact layer 31)

Finally, a p-side contact layer 31 made of p-type GaN doped
with Mg to $2 \times 10^{20}/\text{cm}^3$ is grown to the thickness of 150 angstroms.

After the completion of the reaction, the wafer is annealed
at 700°C within the nitrogen atmosphere in the reactor to make the
10 p-type layers less resistive. After annealing, the wafer is
removed out of the reactor and as shown in Fig. 2, the p-side contact
layer 31 and the p-side cladding layer 30 which are the uppermost
layers are etched with RIE apparatus into a ridge geometry with
a stripe width $4 \mu\text{m}$. Particularly, when the nitride semiconductor
15 layers containing Al which are above the active layer are formed
in the ridge geometry, the emission from the active layer focuses
under the stripe ridge, with the result that the transverse mode
is easily simplified and the thresholds are easily decreased.
After the ridge is formed, a mask is formed on the ridge and as
20 shown in Fig. 2, the surface of the second nitride semiconductor
layer 23 on which n-electrode 34 is to be formed is exposed
symmetrically relative to the stripe ridge.

Next, the p-electrode 32 made of Ni/Au is formed on the
entire surface of the ridge. Meanwhile, an n-electrode made of
25 Ti and Al is formed on the almost entire surface of the second
nitride semiconductor layer 23 of a stripe. The almost entire

surface means the area having 80% or more of the surface. Thus, it is extremely advantageous in decreasing the thresholds to expose the second nitride semiconductor layer 23 symmetrically relative to the p-electrode 32 and provide with an n-electrode on the almost
5 entire surface of the second nitride semiconductor layer 23. Next, an insulating film 35 made of SiO₂ is formed between the p-electrode and the n-electrode. A p-pad electrode 33 made of Au is formed which is connected electrically to the p-electrode 32 via the insulating film 35.

10 After the electrode is formed, the back surface of the sapphire substrate of the wafer is polished to the thickness of about 50 μm. And then, the polished plane is scribed and the wafer is cleaved into bars perpendicularly with respect to the stripe electrode to fabricate a resonator on the cleaved facet. A
15 dielectric film made of SiO₂ and TiO₂ is formed on the facet of the resonator and finally, the bar is cut parallel to the p-electrode, resulting in laser devices. The resulting device is onto the heat sink. When the laser oscillation was tried at room temperature, the continuous emission at a wavelength of 405 nm was observed .
20 The threshold current density was 2.5 kA/cm² and the threshold voltage was 4.0 V. The lifetime was 500 hours or longer and enhanced 10 times or more, compared with the conventional nitride semiconductor laser device.

Example 9

25 LED in the form of the three layer laminated structure
Undoped In_{0.05}Ga_{0.95}N//Si doped n-type GaN//undoped GaN

The LED device is fabricated in the same manner as in Example 1, except that a third nitride semiconductor layer made of undoped $\text{In}_{0.05}\text{Ga}_{0.95}\text{N}$ is grown to the thickness of 20 angstroms using TMG, TMI and ammonia at 800°C . The resulting LED device had almost
5 the same properties as those in Example 7.

For the three layer laminated structure, the principal object is that the carrier concentration in the second nitride semiconductor layer which functions as a n-type contact layer is increased, resulting in obtaining the contact layer which has an
10 as low resistivity as possible. Therefore, the first nitride semiconductor layer may be doped with an n-type impurity within the range where the decrease of the resistivity in the second nitride semiconductor layer is not substantially influenced. The second nitride semiconductor layer is doped with an n-type impurity
15 in high concentration and the third nitride semiconductor layer is formed in order that the n-type cladding layer, the active layer and the like which are formed over the second nitride semiconductor layer may have a good crystallinity. It should be understood that the doping of an impurity within the range where the object of the
20 invention can be achieved be within the scope of the present invention. When the first or third nitride semiconductor is substantially doped with Si to not more than $1 \times 10^{17}/\text{cm}^3$, the occurrence of leak current and a little decrease of the output is observed, but the resulting device can be practically useful (see
25 the following Example 9 or 11). Such a phenomenon can be applied to the case of the n-type contact layer in the form of a super lattice

structure. Therefore, in the structure of undoped InGaN/Si doped n-type GaN or super lattice structure/undoped GaN, or undoped GaN/Si doped n-type GaN or super lattice structure/undoped GaN of the above-mentioned Examples, at least either first or third nitride semiconductor layer may be doped with an n-type impurity, as long as the second nitride semiconductor layer is not substantially influenced.

Example 10

LED in the form of a super lattice three layer laminated structure
 10 Undoped InGaN/undoped GaN//Si doped GaN//undoped GaN

With the same procedures as in Example 1, the buffer layer 2 is formed and then the first nitride semiconductor layer 3 made of undoped GaN is grown to the thickness of 1.5 μm on the same conditions as in Example 1.

15 Next, at 1050°C, using TMG, ammonia gas and Si gas, a second nitride semiconductor layer 4 is formed by growing a Si doped GaN layer doped with Si to $1 \times 10^{19}/\text{cm}^3$ to the thickness of 2.25 μm .

And then, at 1050 °C, using TMG and ammonia gas, an undoped
 20 GaN layer is grown to the thickness of 20 angstroms and subsequently, at 800 °C, using TMI, TMG and ammonia gas, an undoped InGaN layer is grown to the thickness 10 μm . Thus, a third nitride semiconductor layer is made by laminating alternately A layer made of an undoped GaN layer with the thickness of 20 angstroms and B
 25 layer made of undoped InGaN layer with the thickness of 10 angstroms, in 20 layers, respectively, thereby forming a super lattice

structure having a total thickness of 600 angstroms. Other constructions are the same as those in Example 1.

The resulting LED of Example 10 had the same properties as those in Example 7.

5 Example 11

LED in the form of a three layers laminated LED

Undoped GaN//Si doped n-type GaN//Si doped GaN

With the same procedures as in Example 7, the first nitride semiconductor layer 3 is doped with Si to $1 \times 10^{17}/\text{cm}^3$, the second
 10 nitride semiconductor layer made of GaN 4 is doped with $8 \times 10^{16}/\text{cm}^3$, and the third nitride semiconductor layer 5 is an undoped layer. The other constructions are the same as in Example 7. In the resulting device, a little leak current was observed and the output decreased a little.

15 Example 12

LED in the form of three layers laminated structure

Si doped GaN//Si doped n-type GaN//undoped GaN

With the same procedures as in Example 7, the third nitride semiconductor layer 5 is doped with Si to $1 \times 10^{17}/\text{cm}^3$, the second
 20 nitride semiconductor layer made of GaN 4 is doped with $8 \times 10^{16}/\text{cm}^3$, and the first nitride semiconductor layer 5 is an undoped layer. The other constructions are the same as in Example 7. In the resulting device, a little leak current was observed and the output decreased a little.

25 Example 13

LED in the form of three layer laminated structure

Si doped GaN//Si doped n-type GaN//Si doped GaN

With the same procedures as in Example 7, the first and third nitride semiconductor layers 3 and 5 are doped with Si to $8 \times 10^{16}/\text{cm}^3$, and the second nitride semiconductor layer made of GaN 4 is doped with $5 \times 10^{18}/\text{cm}^3$. The other constructions are the same as in Example 7. In the resulting device, almost no leak current was observed and the output decreased a little.

Example 14

LED in the form of super lattice three layers laminated structure
 10 Undoped GaN/Si doped GaN//Si doped GaN//undoped GaN

With the same procedures as in Example 1, the buffer layer 2 is formed and then, the first nitride semiconductor layer 3 made of undoped GaN is grown to the thickness of $1.5 \mu\text{m}$ on the same conditions as in Example 1.

15 Next, at 1050°C , using TMG, ammonia gas and Si gas, the second nitride semiconductor layer 4 is formed by growing Si doped GaN layer which is doped with Si to $1 \times 10^{19}/\text{cm}^3$ to the thickness of $2.25 \mu\text{m}$.

Subsequently, at 1050°C , using TMG and ammonia gas, an
 20 undoped GaN layer is grown to the thickness of $75 \mu\text{m}$. At the same temperature, using TMG, ammonia gas and Si gas, a Si doped GaN layer which is doped with Si to $1 \times 10^{19}/\text{cm}^3$ to the thickness of 25 angstroms. Thus, the third nitride semiconductor layer is formed by laminating alternately an undoped GaN layer having a thickness of 75 angstroms
 25 and the Si doped GaN layer having a thickness of 25 angstroms, thereby forming the super lattice structure having a total

thickness of 600 angstroms.

The other constructions are the same as in Example 1.

The resulting LED in the form of the super lattice structure according to the Example 14 had similar properties to those in
5 Example 7.

WHAT IS CLAIMED IS:

1. A nitride semiconductor light emitting device which comprises at least a substrate, an n-type contact layer for forming an n-electrode, an active layer where electrons and holes are recombined and a p-type contact layer for forming a p-electrode, each layer being made of nitride semiconductor, wherein said n-type contact layer comprises a nitride semiconductor doped with an n-type impurity and has a first surface and a second surface, on which a first and a second undoped nitride semiconductors are formed respectively to make a three-layer laminated structure.
2. A nitride semiconductor light emitting device according to claim 1, wherein said n-type contact layer is GaN doped with Si as an n-type impurity, and said first nitride semiconductor joined to the first surface of said n-type contact layer is undoped GaN or AlGaN while said second nitride semiconductor joined to the second surface of said n-type contact layer is one of undoped GaN, AlGaN and InGaN.
3. A nitride semiconductor light emitting device according to claim 2, wherein said n-type contact layer has a carrier concentration of $3 \times 10^{18}/\text{cm}^3$ or more.
4. A nitride semiconductor light emitting device according to claim 2 or 3, wherein said n-type contact layer has a resistivity of $8 \times 10^{-3} \Omega \text{cm}$ or less.
5. A nitride semiconductor light emitting device according to claim 1, wherein said n-type contact layer of the three-layer structure is formed on a buffer layer formed on a sapphire

substrate.

6. A nitride semiconductor light emitting device which comprises at least a substrate, an n-type contact layer for forming an n-electrode, an active layer where electrons and holes are recombined and a p-type contact layer for forming a p-electrode, each layer being made of nitride semiconductor, wherein said n-type contact layer comprises a super-lattice layer which comprises a laminate layer of at least a nitride semiconductor layer doped with an n-type impurity and a nitride semiconductor undoped with an n-type impurity.

7. A nitride semiconductor light emitting device according to claim 6 wherein said n-type contact layer comprises super-lattice layer of combination of nitride layers selected from the group consisting of GaN/GaN, InGaN/GaN, AlGaN/GaN and InGaN/AlGaN, at least either one of which is doped with Si.

8. A nitride semiconductor light emitting device according to claim 7, wherein said n-type contact layer has a carrier concentration of $3 \times 10^{18}/\text{cm}^3$ or more.

9. A nitride semiconductor light emitting device according to claim 7 or 8, wherein said n-type contact layer has a resistivity of $8 \times 10^{-3} \Omega \text{cm}$ or less.

10. A nitride semiconductor emitting device according to claim 6, wherein said n-type contact layer comprises a nitride semiconductor super-lattice doped with an n-type impurity and has a first surface and a second surface, on which a first and a second layers of undoped nitride semiconductor or nitride semiconductor

doped with a n-type impurity less than that of said super
super-lattice are formed respectively to make a three-layer
laminated structure.

11. A nitride semiconductor emitting device according to claim
5 7, wherein said n-type contact layer is formed on an undoped GaN
layer formed on a buffer layer which is formed on a sapphire
substrate, further nitride semiconductor layer comprising said
active layer is formed through GaN undoped with n-impurity on said
n-type contact layer.

10 12. A nitride semiconductor light emitting device which
comprises at least a substrate, an n-type contact layer for forming
an n-electrode, an active layer where electrons and holes are
recombined and a p-type contact layer for forming a p-electrode,
each layer being made of nitride semiconductor, wherein said n-type
15 contact layer of GaN comprises a nitride semiconductor doped with
Si as an n-type impurity and has a first surface and a second surface,
on which a first and a second nitride semiconductors are formed
respectively, at least one of the first and second nitride
semiconductors is doped with Si in an amount of less than that
20 of said n-type contact layer, and wherein said first nitride
semiconductor joined to the first surface of said contact layer
is of GaN or AlGa_N while the second nitride semiconductor joined
to the second surface of said contact layer is of GaN, AlGa_N or
InGa_N.

Fig. 1

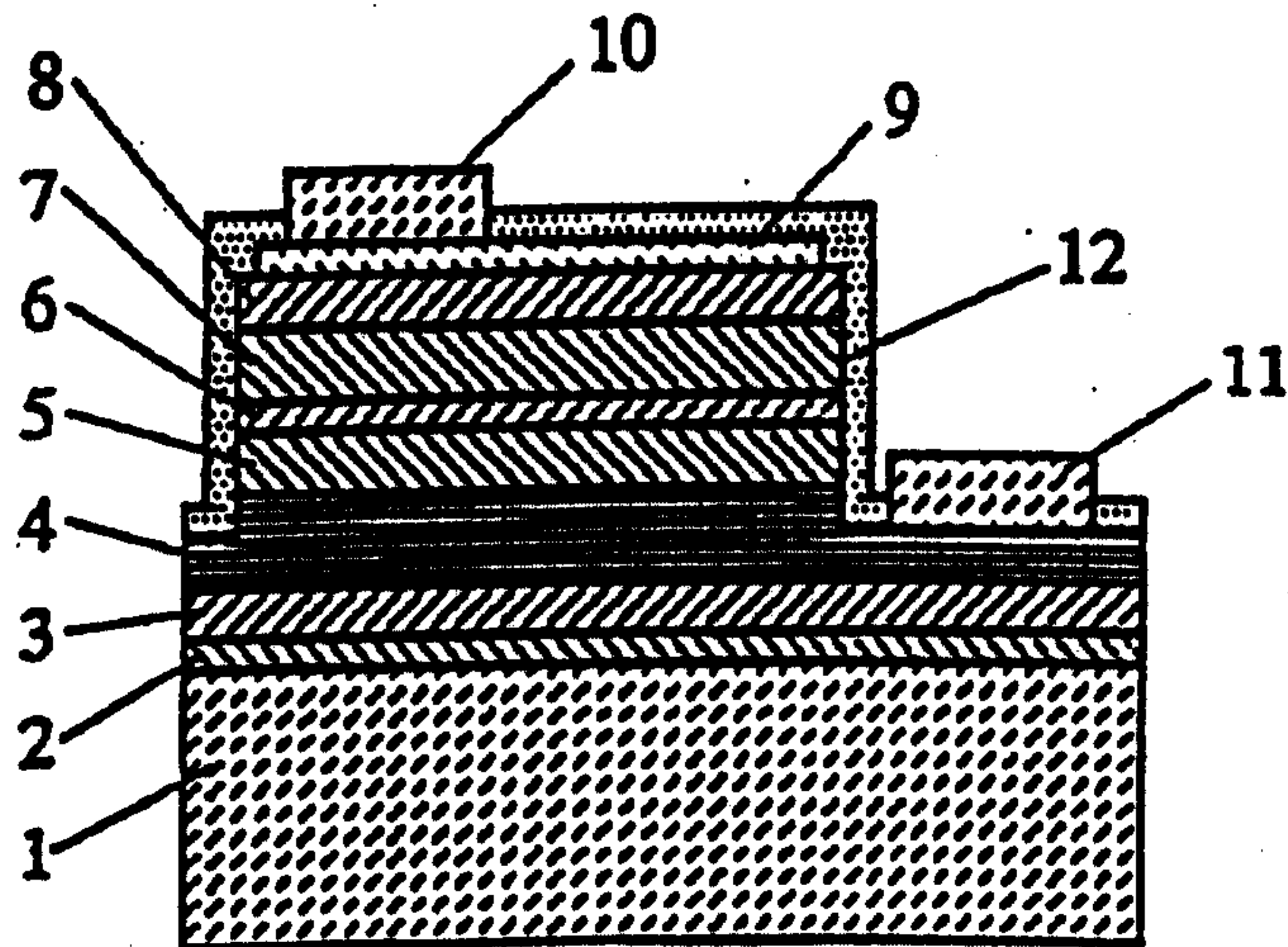

Fig. 2

