

[54] **ROOF FLANGE WITH ELASTOMERIC COLLAR** 3,098,663 7/1963 Dibley .....285/43

[72] Inventor: **Craig S. Gustafson**, Blueberry Lane, Lincoln, Mass. 01773

*Primary Examiner*—David J. Williamowsky  
*Assistant Examiner*—Wayne L. Shedd  
*Attorney*—John Noel Williams

[22] Filed: **Aug. 5, 1970**

[21] Appl. No.: **61,099**

[57] **ABSTRACT**

[52] U.S. Cl. ....285/43, 285/423

[51] Int. Cl. ....E04d 13/00

[58] Field of Search .....285/42, 43

Roof flanges with elastomeric collars having improved sealing characteristics. With the collar belling gradually from its opening, defining a convex surface engaging the pipe over a substantial distance, a liquid-tight seal results despite variations in the size or surface of the pipe. A pre-applied lubricant on the sealing surface enables attachment of high pressure collars while improving sealing.

[56] **References Cited**

**UNITED STATES PATENTS**

3,313,559 4/1967 Kifer .....285/43

**6 Claims, 8 Drawing Figures**

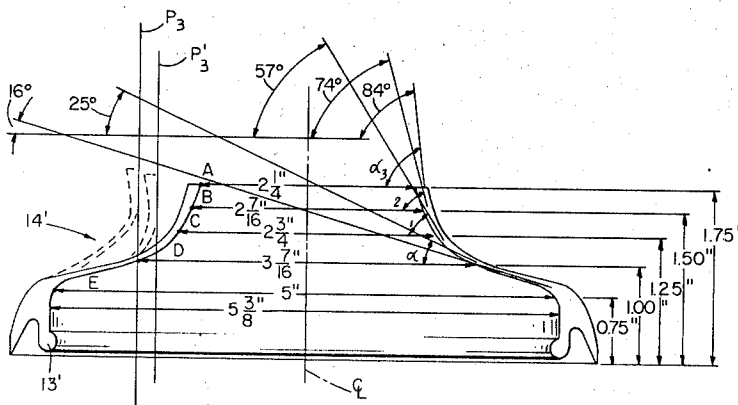

FIG 1

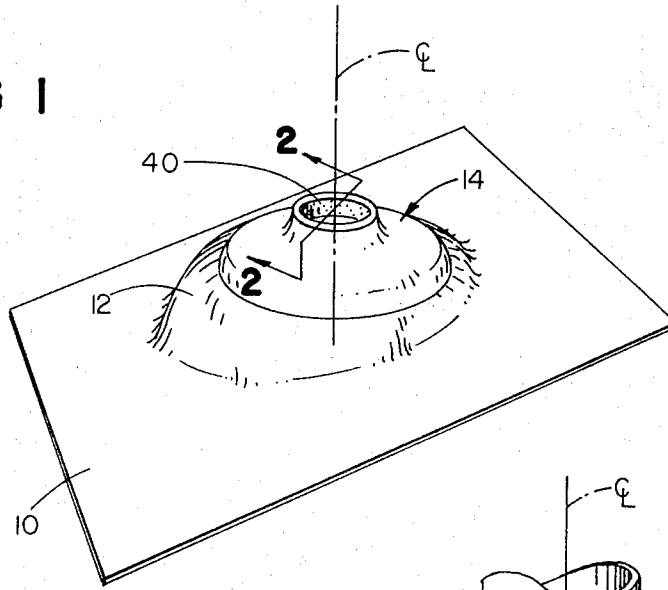

FIG 4

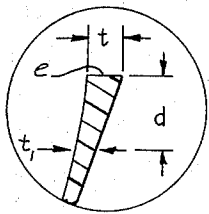
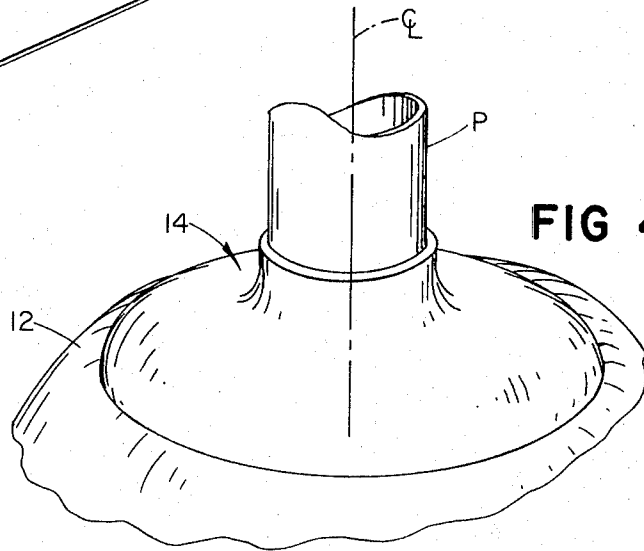
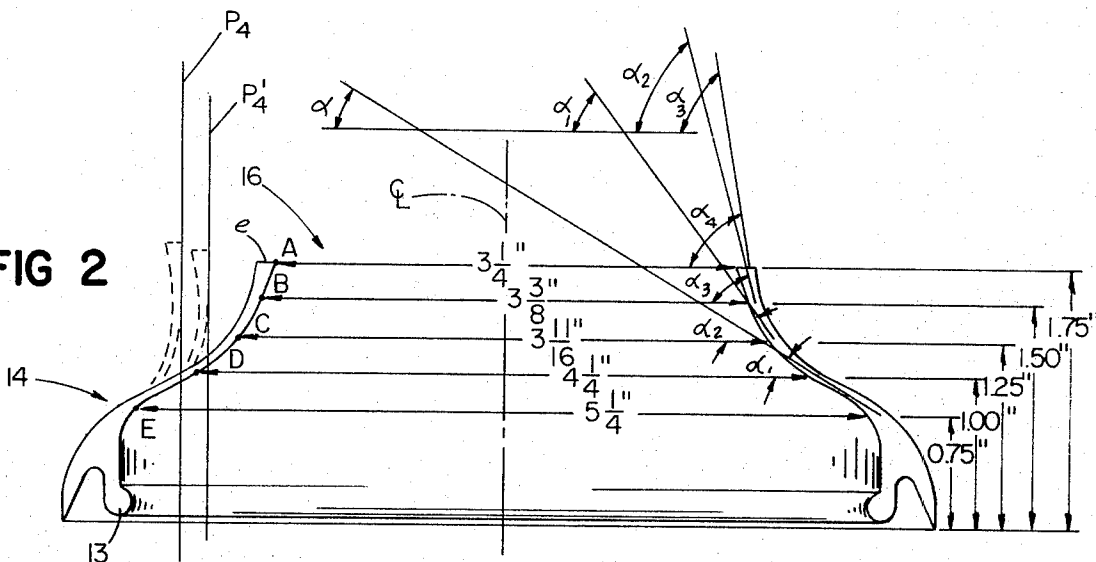

FIG 2a

FIG 2



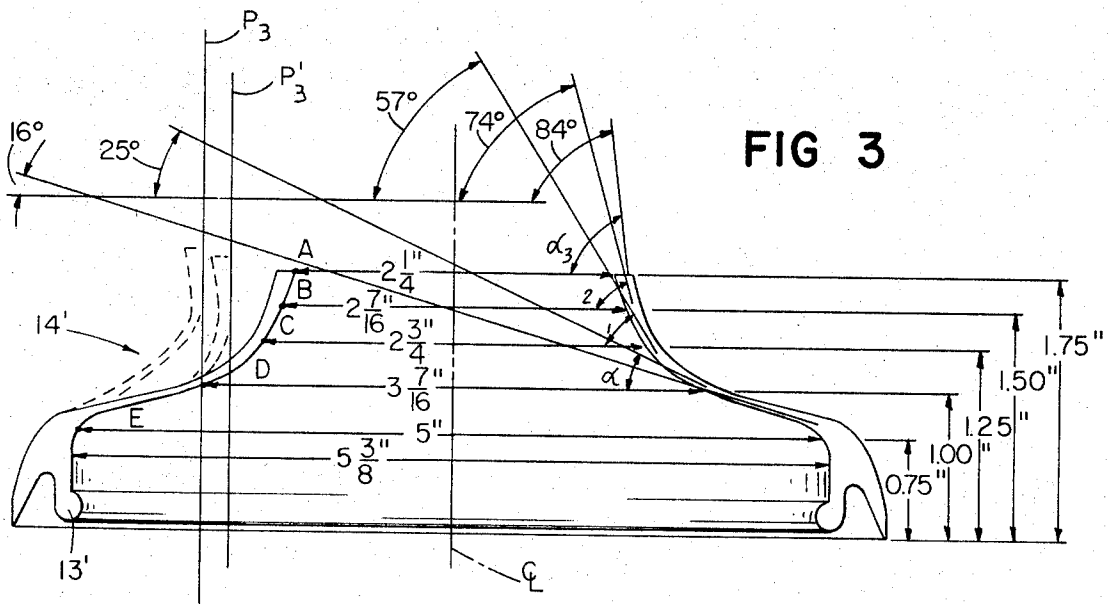

FIG 3

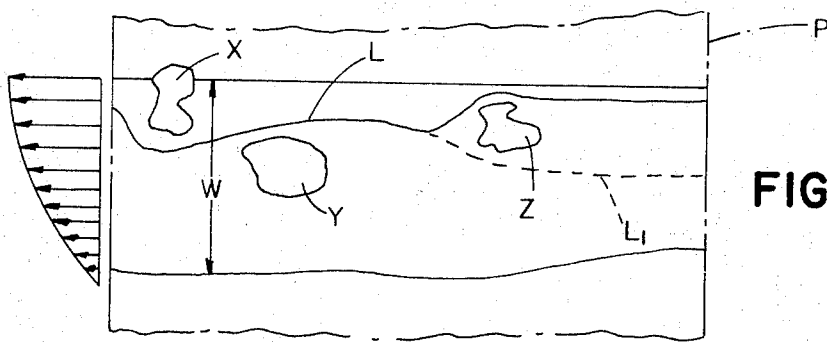

FIG 5

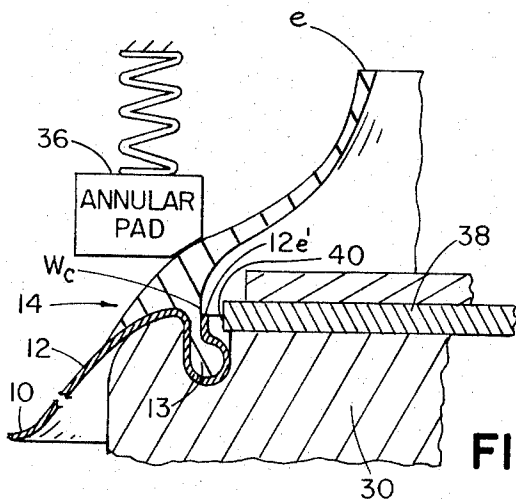

FIG 6

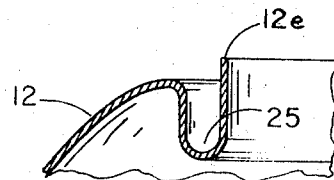

FIG 6a

## ROOF FLANGE WITH ELASTOMERIC COLLAR

This invention relates to roof flanges for sealing against rain and other leakage about pipes that protrude from the roof.

At least since 1957 it has been proposed to employ a roof flange unit which is applied as one piece, providing a flange for sealing with the shingles or other composition of a roof and an elastomeric collar for gripping and sealing to the periphery of a pipe extending through the roof.

The patent literature, for example, shows Church, U.S. Pat. No. 2,985,465. Since the advent of such units, there has been a considerable effort, without complete success, of providing such a roof flange that will accept and completely seal about pipes varying in size and surface texture. In the patent literature there are Canadian Pat. 640,736 and U.S. Pat. Nos. 3,098,663 and 3,313,559, to mention a few.

While various such units have been used widely in the field, there has been a certain frequency of leaks developing about the pipes. This has been enough to cause many in the construction industry not to adopt this style of roof flange unit but to continue with other styles, i.e., metal units having lead or fibrous packing, etc., despite the inconvenience as well as possibility of leaks provided by such other styles.

The principal objects of this invention are to provide an improved roof flange and in particular a flange which significantly decreases the likelihood of leaks despite variation in pipe surface and size.

According to the invention, there is featured an elastomeric collar in the region to be engaged by the pipe, which comprises a thin wall of truncated bell shape in unstressed condition. The shape commences substantially at the opening of the collar and bells outwardly, downwardly, exposing a convex smooth sealing surface to the pipe. The unit is adapted to be pressed down over the pipe until the flange seats on the roof. After application to the pipe, resilient hoop stresses are developed in the collar about the pipe, the resilient deformation commencing at the collar opening decreasing only gradually downwardly along the bell-shaped wall for a distance on the order of one half inch.

Preferred embodiments of the invention feature: a total bell-shaped wall length in the range of at least one inch; the angle of the wall to the radial varying gradually from substantially 90° at the opening to less than 45° at the most remote point; the wall joined at its remote point to a thick resilient attachment bead to which is permanently crimped a metal flange member; and the wall thickness at the opening decreasing gradually over almost one-fourth inch from a thickness at the opening on the order of 0.100 inch.

The invention also features a pre-applied coating of water-resistant lubricant on the substantial convex area of the collar which is arranged to engage the pipe, preferably featuring a silicone lubricant waterproofing agent.

These and other objects and features will be understood from the following detailed description taken in conjunction with the drawings wherein:

FIG. 1 is a perspective view of a preferred embodiment of the invention;

FIG. 2 (taken on line 2—2 of FIG. 1) and FIG. 3 are somewhat diagrammatic cross-sections illustrating different sizes of the unit of FIG. 1;

FIG. 2a is a cross-sectional view on an enlarged scale of the outer portion of the collar wall of FIG. 2;

FIG. 4 is a perspective view of the unit in place;

FIG. 5 is a development of the sealing area in diagrammatic form; and

FIG. 6 is a cross-sectional view illustrating a step in the manufacture of the unit, FIG. 6a showing the metal port pre-assembly.

Referring to FIG. 1, the unit comprises a conventional metal flange 10 and domed portion 12, e.g., an embossure, the latter being crimped on its upper region about an attachment bead 13 of the collar 14. As is common, the domed portion sets the axis  $\phi$  of the collar at an angle to the plane of the flange to correspond to the difference in angle between an average roof pitch and vertical pipes protruding through the roof.

Referring to FIG. 2, the collar is drawn to scale for use with a standard 4 inch I.D. pipe (being suitable for both cast iron and plastic pipes having an O.D. of 4-½ inches, with tolerances and copper pipe having an O.D. of 4-½ inches, with tolerances).

The collar, beginning at opening 16 comprises a membrane wall which bells outwardly downwardly a substantial distance. More particularly, points A, B, C, D, and E are points along the wall proceeding at one-fourth inch increments in the direction of the axis  $\phi$ , point A being at the top opening of the collar. In the unstressed conditions, the points lie at the following diameters and the angle of the wall at those points relative to the radial plane of the collar are given in the following table:

TABLE I

Point	Axial Distance from Opening	Angle $\alpha$ to Radial Plane	Unstressed I Diameter
A 0		80°	3-1/4"
B 1/4"		75°	3-3/8"
C 1/2"		53°	3-11/16"
D 3/4"		32°	4-1/4"
E 1"		32°	5-1/4"

The collar of the preferred embodiment is of molded neoprene while, referring to FIG. 2a, the thickness  $t$  of the wall at the outer edge  $e$  (at the opening 16) in this preferred embodiment is 0.093 inch and the wall thickness decreases uniformly to a thickness  $t_1$  of 0.065 inch at a distance  $d$  of about one-fourth inch from the edge  $e$ , thereafter the wall being of substantially uniform thickness.

On the left hand side of FIG. 2 there is shown a vertical line  $P_4$  representing a standard 4 inch cast iron or plastic pipe (of O.D. 4-½ inches) and line  $P_4'$  representing a standard 4 inch copper pipe (of O.D. 4-½ inches). It is seen (also see FIG. 4) that the wall (in unstressed condition of bell shape) now is stretched to conform to the pipe surface over a substantial distance, resiliently applying sealing hoop stresses to the pipe. The sealing surface of the pipe, convexly bell-shaped and smooth in unstressed condition now is of cylindrical form in the contact area. The amount of resilient deformation of the wall decreases only gradually at a less than linear rate of change downwardly (as compared to a truncated cone projected through points A and E) along the wall for a distance of at least one half inch as shown in the following table and by the arrows in FIG. 5, taking an average pipe position intermediate  $P_4$  and  $P_4'$ :

TABLE II

Point I.D.	Unstressed I.D.	Stressed $\Delta$	% of stressed diameter attributable to elastic distension	
A	3-1/4"	4-1/4"	1"	23-1/2%
B	3-3/8"	4-1/4"	7/8"	20-1/2%
C	3-11/16"	4-1/4"	9/16"	13-1/2%
D	4-1/4"	4-1/4"	0	0

The result is that pipes, of either cast iron, plastic or copper having the same standard I.D. (despite differences in standard O.D.) and even, in each case, when at either side of the allowable tolerances (or even out of tolerance or out of alignment) are all sealed effectively by the collar when applied. Referring to FIG. 5, (a development of the gripped area on the pipe), the collar surface is smooth and grips over a wide area  $W$  effectively isolating any surface discontinuity  $X$ ,  $Y$  or  $Z$  and assures that a seal is perfected about the periphery even in the presence of excrescences gross depressions and the like (see seal line  $L$  and alternate seal line  $L_1$ ). In many such cases the collar material need not seal into the depression, but rather seals entirely around it so that the depression affords no path for rain leakage from exterior to interior of the pipe.

As noted from the above tables, significant stretching of the collar occurs over a large area during placement. Resistance against tearing of the collar at its outer edge during placement is provided by the tapered thickness mentioned above.

According to the invention, a lubricant coating 40 shown by dots in Fig. 1 is pre-applied at the factory to the inner convex, belled surface from about point A to D. Suitably, an aerosol spray known as "Marvel" silicone spray is employed, sold by Marvel Oil Company, Inc., of Port Chester, New York, as a lubricant and waterproofing agent.

A given unit not carrying the lubricant may require excessive force causing damage to the unit when applied to a given pipe, but with the lubricant present, the unit is found to slip on easily, the lubricant further serving to perfect the water-tight seal.

The embodiment of FIG. 3 is adapted for use with standard 3 inch pipes (being suitable for both cast iron and plastic pipes having an O.D. of 3-1/2 inches, with tolerances, and copper pipe having an O.D. of 3-1/8 inches, with tolerances).

The collar is constructed according to the same principles as above, and in this embodiment has the same diameter mounting bead 13', the wall being correspondingly longer and having a near horizontal extent adjacent the bead.

The following tables III and IV for this embodiment correspond, respectively, to tables I and II of the preceding embodiment.

TABLE III

Point	Axial distance from opening	Angle $\alpha$ to radial plane	Unstressed I. Diameter
A	0	84°	2-1/4"
B	1/4"	74°	2-7/16"
C	1/2"	57°	2-3/4"
D	3/4"	25°	3-7/16"
E	1"	16°	5"

TABLE IV

Point	Unstressed I.D.	Stressed I.D.	$\Delta$	% of stressed diameter attributable to elastic distension
A	2-1/4"	3-1/4"	1"	31%
B	2-7/16"	3-1/4"	13/16"	25%
C	2-3/4"	3-1/4"	1/2"	15-1/2%
D	3-7/16"	3-7/16"	0	0

Referring now to FIG. 6, the elastomeric collar 16 is assembled with the metal plate at the factory by a crimping operation. In FIG. 6a is shown the relevant portion of the metal ring in cross section, defining a trough 25 which extends a full circle about an opening in the metal plate. The peripheral bead of the collar is inserted in the metal trough and the combination is placed on a crimping machine. An anvil 30 engages the lower surfaces of the metal plate and an annular member 36 is lowered, its pressure ensuring that the bead seats upon the bottom of the trough. Crimping jaws 38 of matching circular configuration then move outwardly, the jaws having a peripheral crimping surface 40 which extends both above and below the upper edge 12e of the metal piece. Upon radial movement of the crimping jaw, the upper edge 12e and its margin are pressed outwardly, conforming about the bead and pressing against or into the vertical wall Wc of the collar. The finished edge 12e' and margin is thus pressed tightly against and into the elastomer ensuring a tight seal and firm grip which resists pull-out of the bead 13 from the metal piece during application of the unit to the roof pipe.

In partial summary, the previously mentioned objects are achieved in the following manner: (1) The essentially cylindrical sleeve portion of the small end of the truncated bell-shaped membrane compared with other designs such as a

truncated cone or annular disc shape, provides a superior pressure seal for any given undistended opening diameter. (2) In addition, the inside curved contour just below the sleeved portion of the truncated bell-shaped membrane particularly when compared with an annular disc type membrane provides an ease of lead in feature during installation. This feature is completely lacking in the annular disc. (3) Also, the additional material inherent in the truncated bell-shaped configuration when compared with a truncated cone of comparable dimensions or, particularly, an annular disc of equal outside diameter, provides more material to draw from during distension which results in less elongation of the membrane material during installation while still maintaining the previously described superior seal. This feature is of particular importance when other than average roof pitches are encountered which require that the plane of the distended opening be oriented at other than an angle perpendicular to the axis of the upstanding pipe or conduit. The wedge-shaped lip at the small end of the truncated bell-shaped membrane provides added strength to that portion of the membrane that experiences the greatest distension.

The pre-applied lubricant, as mentioned, contributes an ease of application of the unit and further contributes to the liquid tightness of the seal. Its use in other constructions can give certain benefit.

Numerous modifications in the specific details including adaptation to other sizes will be understood from the foregoing description and are within the spirit and scope of the claims.

What is claimed is:

1. In a roof flange unit comprising a flange base for sealing with a roof and a resilient elastomeric collar having a longitudinal axis and an end opening therein, for gripping and sealing to the periphery of a pipe of given standard size extending through the roof, the unit adapted to be applied as one piece over the pipe, the improvement wherein said elastomeric collar, in the region to be engaged upon the pipe, comprises a wall of generally bell-shaped cross-section in radial planes through said axis, said wall commencing substantially at the opening of said collar, said opening being substantially smaller than the outer diameter of said pipe, the wall of said collar, in unstressed condition, bellings outwardly and axially away from said opening exposing an inner convex smooth sealing surface to said pipe, the tangent to the sealing surface of said collar in a plane parallel to said axis in the immediate vicinity of said opening forming an acute angle relative to said axis, and tangents to points on said surface further from said opening forming increasingly larger such angles, whereby upon application of said collar to said pipe, said collar is radially deformed and resilient hoop stresses are developed in the collar about the pipe, the resilient deformation commencing at the collar opening and decreasing only gradually axially along said wall for a distance on the order of one half inch.

2. The roof flange unit of claim 1 wherein said wall has a total effective sealing length, beginning at said opening, in the range of about one inch, the angle of said wall relative to a plane radial to said axis of said collar varying gradually from substantially 90° at said opening to less than 45° at a point most remote from said opening.

3. The roof flange of claim 2 wherein said bell-shaped wall is integrally joined at its point most remote from said opening with a resilient attachment bead of substantially greater thickness than said wall, said collar comprising neoprene rubber, and a metal flange member permanently crimped about said resilient attachment bead.

4. The roof flange unit of claim 1 wherein said collar is formed of neoprene rubber and the wall thickness of said collar at said opening is on the order of 0.100 inch, the thickness of said wall decreasing gradually downwardly over a distance on the order of one-fourth inch.

5. The roof flange unit of claim 1 wherein said collar comprises neoprene rubber of a wall thickness in the range of between 0.100 inch and 0.050 inch, the diameter of said open-

5

6

ing being on the order of one inch less than the corresponding standard pipe outer diameter, and a coating of pre-applied water-resistant lubricant disposed on said convex surface of said collar.

applied water-resistant lubricant is disposed on the surface of said collar adapted to engage said pipe said pre-applied lubricant comprises a thin coating of silicon lubricant-waterproofing agent.

6. The roof flange unit of claim 1 wherein a coating of pre-

\* \* \* \* \*

10

15

20

25

30

35

40

45

50

55

60

65

70

75