

(No Model.)

F. D. GRANGER.

SINGLE TRIGGER OPERATING TWO LOCKS ALTERNATELY.

No. 524,140.

Patented Aug. 7, 1894.

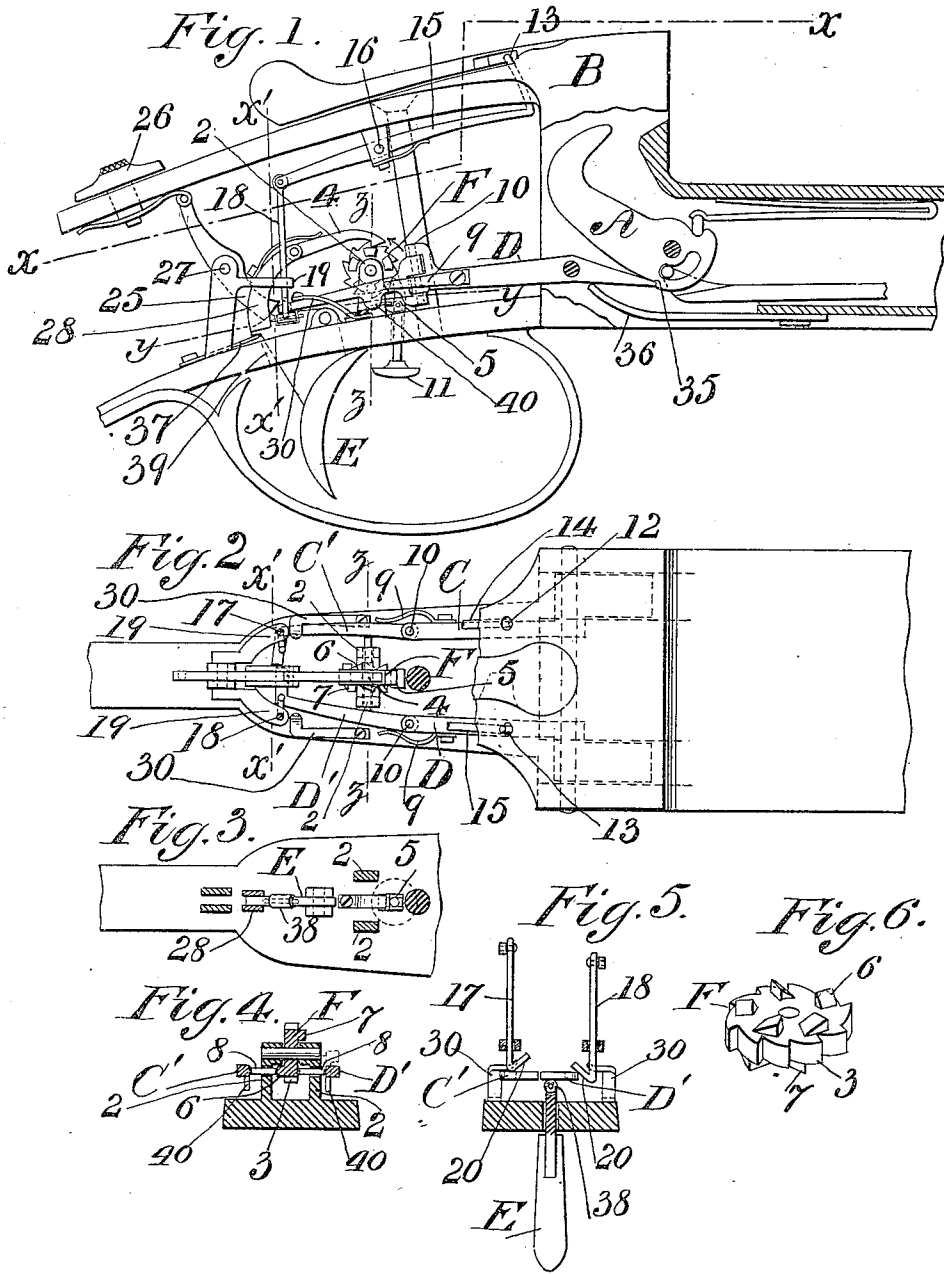

WITNESSES:

K. M. Tucker.
J. Kennedy.

INVENTOR

Frank D. Granger.

BY

Wm. F. Parker.
ATTORNEY

UNITED STATES PATENT OFFICE.

FRANK D. GRANGER, OF NEW YORK, N. Y., ASSIGNOR OF ONE-HALF TO
HALLACK A. PENROSE, OF NEW LONDON, CONNECTICUT.

SINGLE TRIGGER OPERATING TWO LOCKS ALTERNATELY.

SPECIFICATION forming part of Letters Patent No. 524,140, dated August 7, 1894.

Application filed March 8, 1894. Serial No. 502,811. (No model.)

To all whom it may concern:

Be it known that I, FRANK D. GRANGER, a citizen of the United States, and a resident of the city of New York, in the county of New York and State of New York, have invented certain new and useful Improvements in Locks for Firearms, of which the following is a specification.

This invention relates to single trigger mechanism for double-barreled guns, and the object of the invention is principally to afford a direct contact of the trigger with either lock-sear to avoid "creep;" also to provide a simple and effective mechanism to reverse the selection of the barrel to be fired; and also to lock not only the trigger but also the sears when the safety-catch is set.

To these ends the said invention consists of novel mechanism hereinafter described and claimed.

Referring to the accompanying drawings: Figure 1 is a side elevation of the lock mechanism with the breech, partly in section; Fig. 2 a plan view partly in section of Fig. 1, taken on the line $x-x$; Fig. 3, a partial plan view taken on the line $y-y$, Fig. 1; Fig. 4, a cross-section taken on the line $z-z$, Figs. 1 and 2; Fig. 5, a cross-section taken on the line $x'-x'$, Figs. 1 and 2; and Fig. 6 a perspective detail view of the sear-shifting wheel.

The invention is adapted for use in connection with two hammers A, within the breech B, of an automatically-cocked gun, which hammers are restrained and released by respective lock-sears C, D. The sears have jointed sections C' D', pivoted at 10, 10, so as to swing sidewise, to engage alternately with the trigger E. As a convenient means of shifting the sears, a cam-toothed wheel F, is provided, mounted on a permanent axis in bearings 2, 2. The wheel is rotated by means of ratchet teeth 3, with which a pawl 4, attached to a suitable part of the trigger E, engages. A pawl 5 also engages with the ratchet teeth 3.

The pawl 5, is mounted on the stem of the reversing button 11. The wheel F may thereby be rotated and the sears shifted by pressing the button 11 upward to change the selection of barrels at will. Whichever pawl 4 or 5, is

inactive serves as a retaining pawl to prevent retrograde.

The respective series of cam-teeth 6, 7, on opposite sides of the wheel F, have equal numbers of teeth—say five—alternately placed, and in the ratchet series 3, there are twice the number of teeth—say ten—that there are on either series 6 or 7. Pins 8, 8, slide in supports 2, 2, and abut at their outer ends on the jointed sections C', D' of the sears, and at their inner ends extend into the paths of each series of cam-teeth 6, 7. The jointed sections C', D', of the sears are pressed inward by springs 9, 9. When the wheel F, is revolved by its ratchet teeth 3, one tooth at a time, either automatically by the trigger pawl 4, or at will by the pawl 5, as the case may be, the pins 8, 8, are alternately pushed outward by the cam-teeth 6 and 7, shifting the sears accordingly; the tail of one sear being moved off from the trigger by a pin 8, and the tail of the other sear being moved on to the trigger by its spring 9, simultaneously.

In Fig. 5 the sear-section D' is shown in contact with the trigger ready to fire the right-hand barrel of the gun.

The position of the sears, determining the order of firing, is indicated by indicating pins 12, 13, carried on arms 14, 15, pivoted at 16, having depending rods 17, 18, guided at 19, 20 and terminating in beveled ends 20 engaging the extremities of the sears, in the manner more clearly shown in Fig. 5. When either sear is at the position occupied by D' ready to fire, its respective indicator pin is raised at the exposed part as at 13, by the depression of the respective rod, as 18.

The safety-catch 25, is actuated by an external sliding piece 26, or in any other usual or suitable manner, being pivoted at 27. The arm 28 of the trigger is bifurcated for convenience, and the catch 25 may be inserted or withdrawn from the intermediate slot; and when at the position shown, said catch locks not only the trigger E, but also the tail of the sear which happens to be on the trigger. The other sear is locked under its respective step 30; all possibility of the gun "jarring off" being thereby effectually prevented.

It is to be observed that the sears C, D, are

pressed upward at their front extremities against the hammers A at 35, by sear-springs 36, determining thereby the limit of the downward position of the tails of the jointed sections C', D' of the sears, and that the trigger E, is pressed upward with very moderate pressure against the tails of the sears by a small spring 37, and moreover an anti-friction roller such as indicated at 38 may be provided for the tails of the sears to ride on, allowing the shifting motion of the same to be effected with as little resistance as possible. The pull of the trigger is limited so as to permit the pawl 4, to take one tooth 3, of the ratchet at a time, by suitable means, as the abutment of the rear portion of said trigger at the end of the slot in the trigger-plate at 39.

The steps 30, are constructed in the form of springs in order to yield sufficiently to allow for the necessary upward motion of the sear which is off the trigger in cocking.

The ears 40, on the sear-sections C', D', afford downward extensions of the vertical plane surfaces on the inside thereof for the pins 8, to ride on when a sear is lifted in the act of firing.

I claim as my invention and desire to secure by Letters Patent—

1. In a lock for fire-arms, the combination of two hammers, vertically and laterally movable lock-sears respectively to the hammers, a trigger, and means for moving said sears alternately into or out of contact with the trigger.

2. In a lock for fire-arms, the combination of two hammers, vertically and laterally mov-

able lock-sears respectively to the hammers, a trigger, and a trigger actuated cam-wheel for moving said sears into or out of contact with the trigger. 40

3. In a lock for fire-arms, the combination of two hammers, vertically and laterally movable lock-sears respectively to the hammers, a trigger, a wheel bearing alternately arranged series of cam-teeth operating on the respective sears to shift them laterally into and out of contact with the trigger, and a pawl connected with the trigger engaging with teeth on said wheel. 45 50

4. In a lock for fire-arms, the combination of a hammer, a trigger, and a jointed lock-sear laterally movable into or out of contact with the trigger.

5. In a lock for fire-arms, the combination of a hammer, a trigger, a jointed lock-sear laterally movable into or out of contact with the trigger, and an indicating device actuated by the lateral movement of the sear. 55 60

6. In a lock for fire-arms the combination with two vertically and laterally movable lock-sears, a trigger, a safety-catch for locking that sear which is in contact with the trigger, and locking steps for the sears, adapted to prevent vertical movement of that sear which is out of contact with the trigger. 65

Signed at New York, in the county of New York and State of New York, this 6th day of March, A. D. 1894.

FRANK D. GRANGER.

Witnesses:

H. F. PARKER,
K. M. TUCKER.