



US00D341818S

# United States Patent [19]

[11] Patent Number: **Des. 341,818**

Byar

[45] Date of Patent: **\*\* Nov. 30, 1993**

[54] **AUTOMATIC CLIMATE CONTROL UNIT FOR AN AUTOMOBILE**

[57] **CLAIM**

The ornamental design for an automatic climate control unit for an automobile, as shown and described.

[75] Inventor: **Peter Byar, Willingboro, N.J.**

### DESCRIPTION

[73] Assignee: **Interdynamics, Inc., Brooklyn, N.Y.**

FIG. 1 is a top perspective view of an automatic control unit for an automobile, showing my new design with the mounting plate shown in FIGS. 7-10, omitted for clarity of illustration;

[\*\*] Term: **14 Years**

FIG. 2 is a front elevational view thereof;

[21] Appl. No.: **939,355**

FIG. 3 is a top plan view thereof;

[22] Filed: **Sep. 1, 1992**

FIG. 4 is a right side elevational view, the opposite side being a mirror image of that shown except for the buttons;

[52] U.S. Cl. .... **D13/164**

FIG. 5 is a rear elevational view thereof;

[58] Field of Search ..... **D23/324; D12/174;**

**237/2 A; 165/11.1; D13/164, 171**

FIG. 6 is a bottom plan view thereof;

### [56] References Cited

#### U.S. PATENT DOCUMENTS

- |            |        |               |       |         |
|------------|--------|---------------|-------|---------|
| D. 266,083 | 9/1982 | Klaus         | ..... | D13/171 |
| 3,373,934  | 3/1968 | Kolbe et al.  | ..... | 237/2 A |
| 5,226,595  | 7/1933 | Devera et al. | ..... | 237/2 A |

FIG. 7 is a top plan view of my design, to which there is a mounting plate provided;

FIG. 8 is a front elevational view of the design as shown in FIG. 7, the rear being a mirror image of that shown;

FIG. 9 is an end elevational view of the design as shown in FIG. 7, the opposite end being a mirror image of that shown except for the buttons;

FIG. 10 is a bottom plan view of the design shown in FIG. 7.

The broken line showing of numerals in FIG. 1 for illustrative purposes only and forms no part of the claimed design.

Primary Examiner—Wallace R. Burke  
Assistant Examiner—Lisa Lichtenstein  
Attorney, Agent, or Firm—Henry R. Lerner

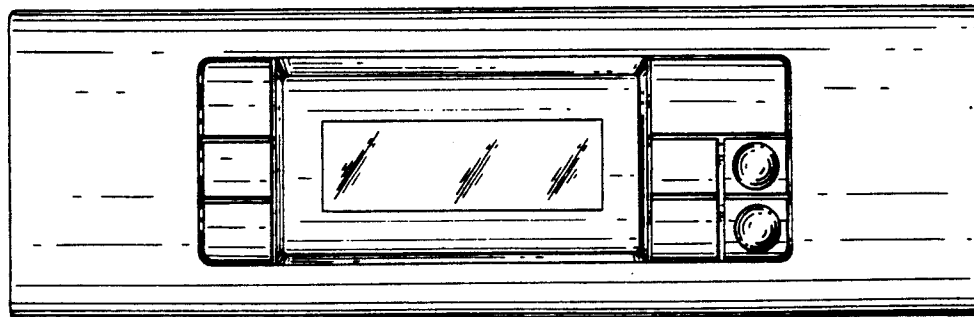
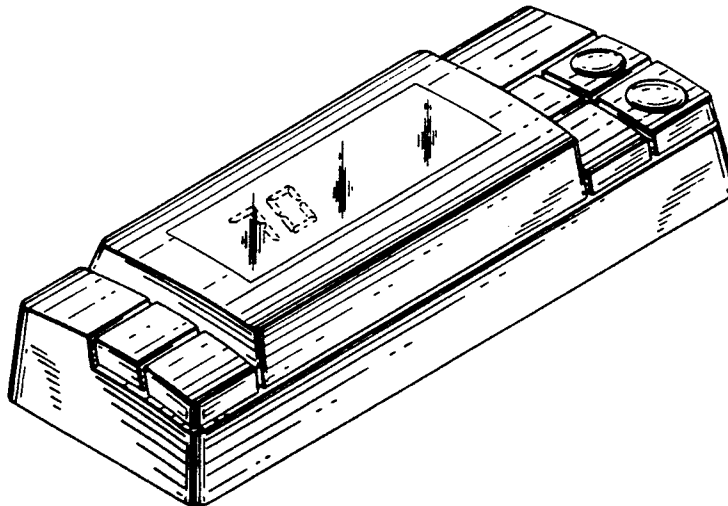

FIG.1

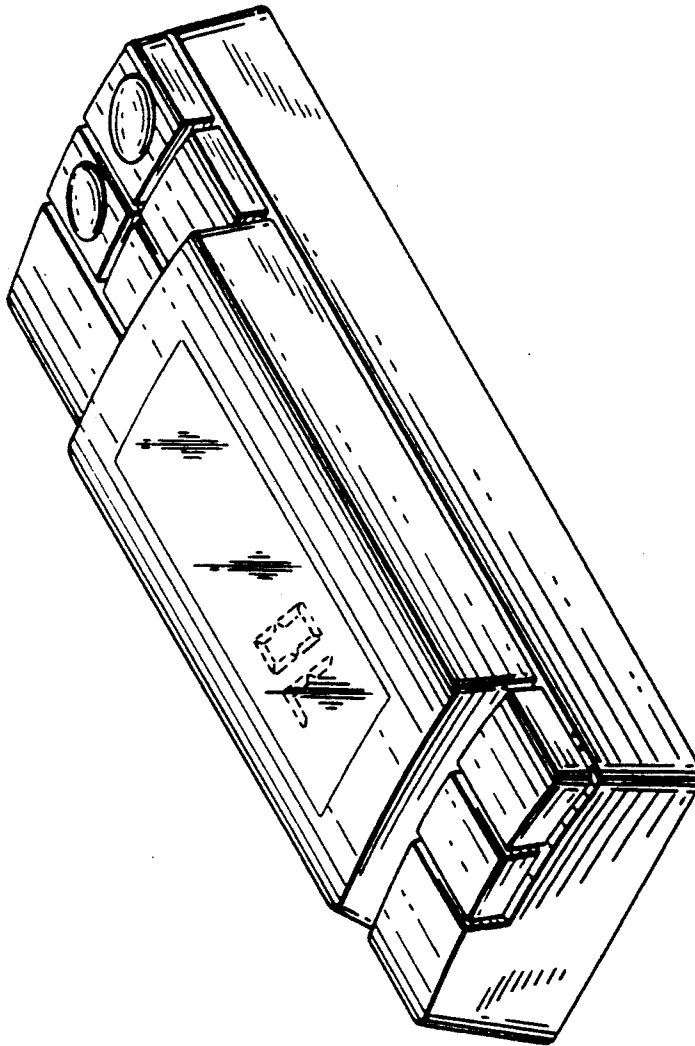
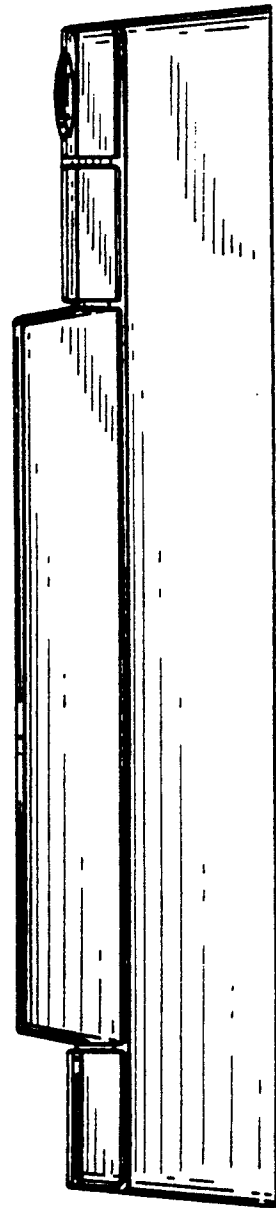

FIG.2



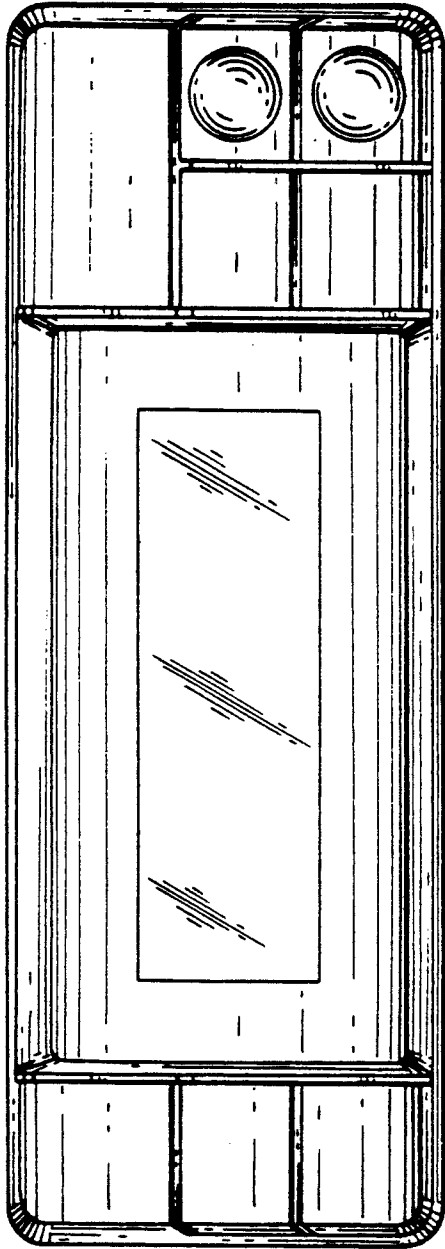
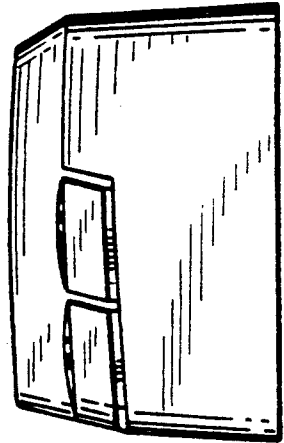

FIG. 3

FIG. 4



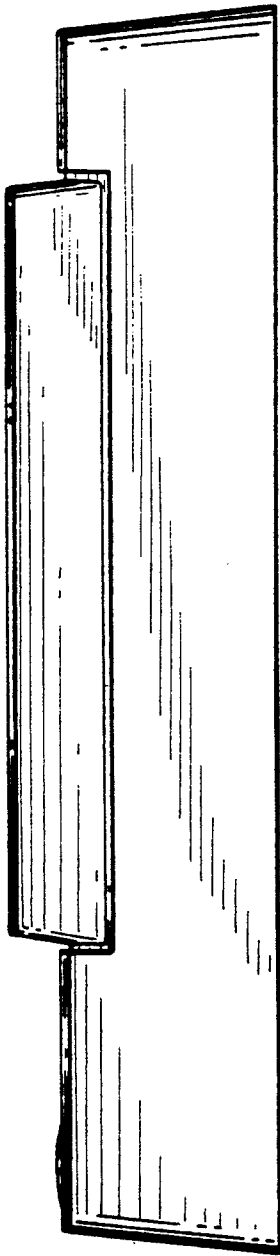

FIG. 5

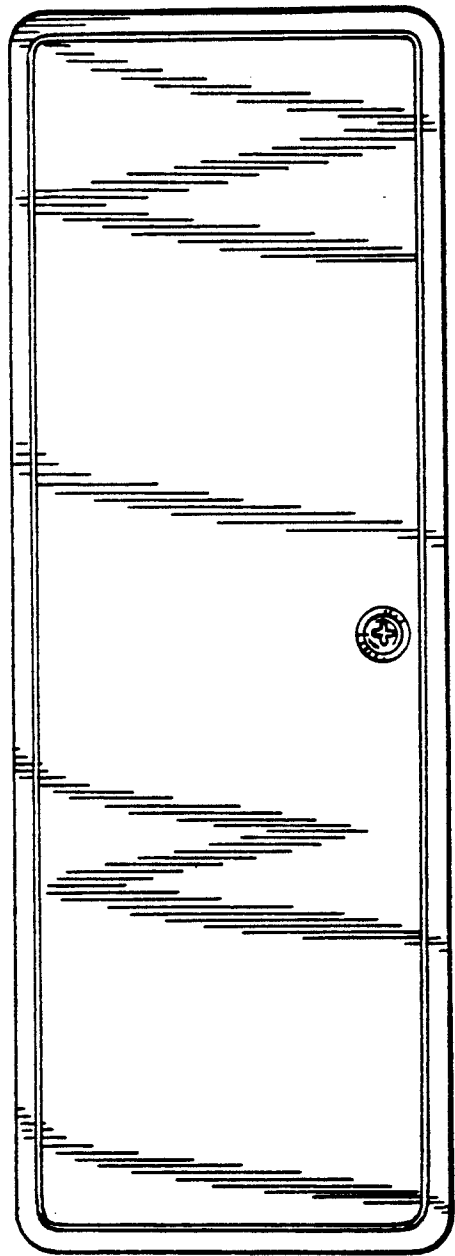

FIG. 6

FIG.7

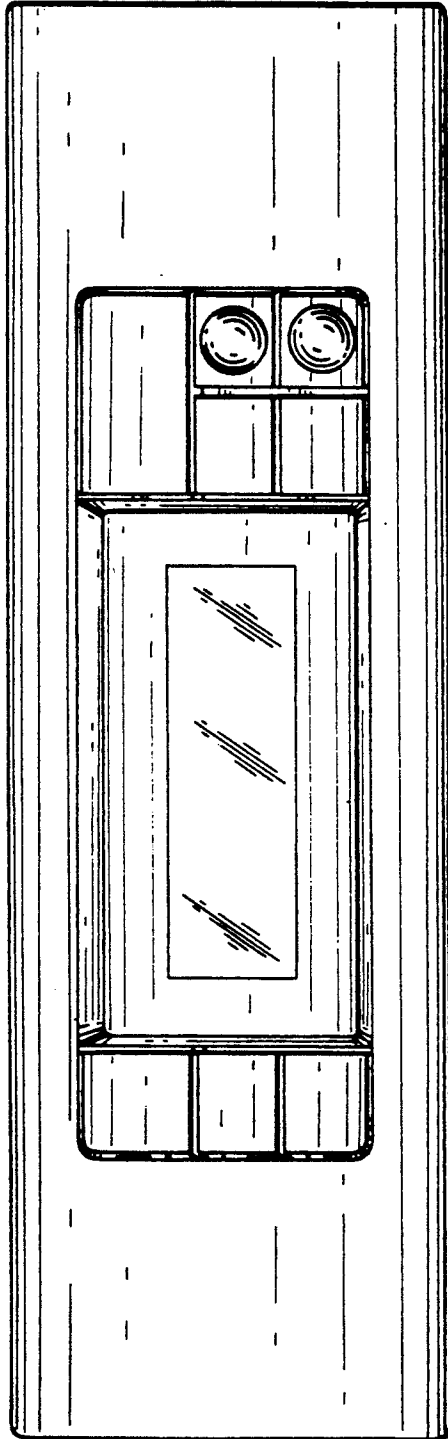
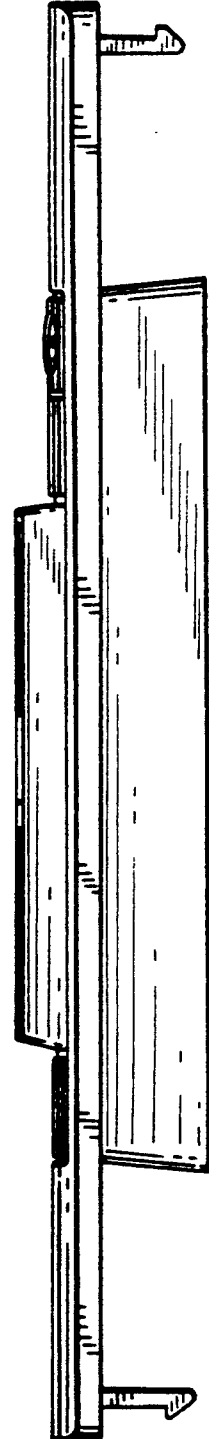

FIG.8



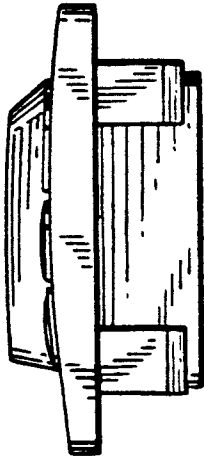

FIG. 9

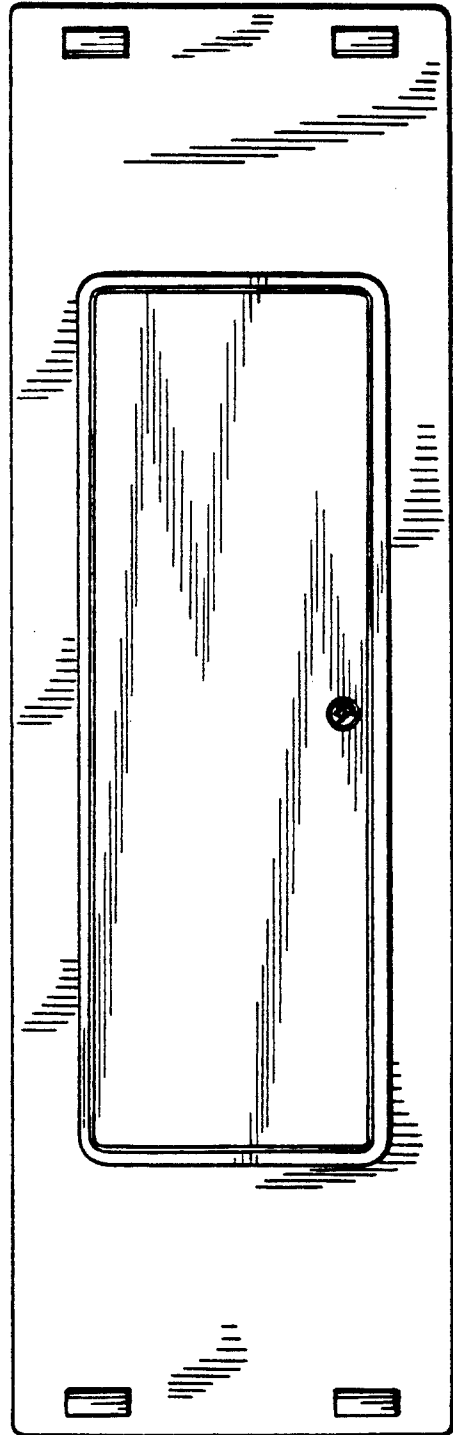

FIG. 10