

INTERNATIONAL APPLICATION PUBLISHED UNDER THE PATENT COOPERATION TREATY (PCT)

<p>(51) International Patent Classification ⁵ : F16L 9/06, B21D 15/04 F28D 7/02</p>	A1	<p>(11) International Publication Number: WO 94/07071</p> <p>(43) International Publication Date: 31 March 1994 (31.03.94)</p>
<p>(21) International Application Number: PCT/NZ93/00087</p> <p>(22) International Filing Date: 22 September 1993 (22.09.93)</p> <p>(30) Priority data: 244431 22 September 1992 (22.09.92) NZ</p> <p>(71)(72) Applicant and Inventor: INNES, Rodney, Mitchell [NZ/NZ]; 1A Onslow Road, Mt Eden, Auckland 1003 (NZ).</p> <p>(74) Agents: HAWKINS, Michael, Howard et al.; Baldwin, Son & Carey, 342 Lambton Quay, Wellington 6001 (NZ).</p> <p>(81) Designated States: AT, AU, BB, BG, BR, BY, CA, CH, CZ, CZ (Utility model), DE, DE (Utility model), DK, DK (Utility model), ES, FI, GB, HU, JP, KP, KR, KZ, LK, LU, LV, MG, MN, MW, NL, NO, NZ, PL, PT, RO, RU, SD, SE, SK, SK (Utility model), UA, US, UZ, VN, Euro- pean patent (AT, BE, CH, DE, DK, ES, FR, GB, GR, IE, IT, LU, MC, NL, PT, SE), OAPI patent (BF, BJ, CF, CG, CI, CM, GA, GN, ML, MR, NE, SN, TD, TG).</p>		<p>Published <i>With international search report.</i></p>

(54) Title: MANUFACTURE OF HELICALLY CORRUGATED CONDUIT

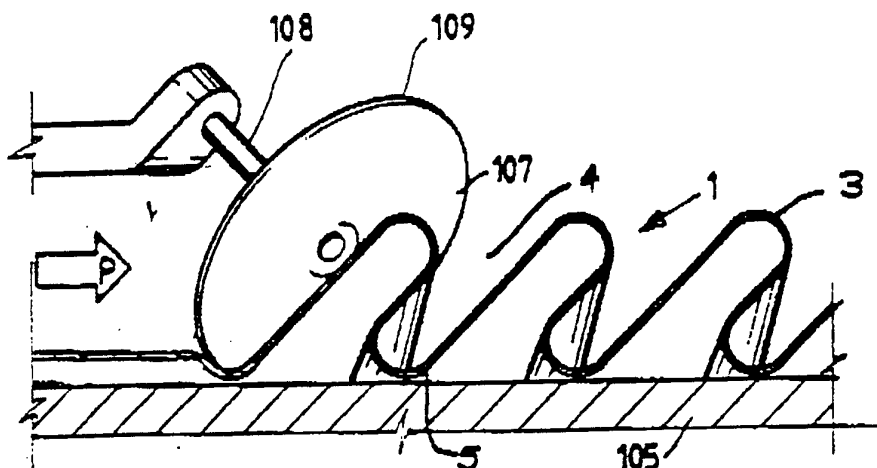

(57) Abstract

This invention concerns the manufacture of helically corrugated conduit having at least a portion of its length corrugated in the form of at least one helix. The method includes the driving of a smooth walled tube into a forming head having forming wheels which engage the outside of the tube and the wheels are at an angle relative to the longitudinal axis of the tube. The forming wheels form the helical spiral as part of a cold rolled forming process. More than one helical spiral can be formed simultaneously using a multiplicity of forming wheels.

FOR THE PURPOSES OF INFORMATION ONLY

Codes used to identify States party to the PCT on the front pages of pamphlets publishing international applications under the PCT.

AT	Austria	FR	France	MR	Mauritania
AU	Australia	GA	Gabon	MW	Malawi
BB	Barbados	GB	United Kingdom	NE	Niger
BE	Belgium	GN	Guinea	NL	Netherlands
BF	Burkina Faso	GR	Greece	NO	Norway
BG	Bulgaria	HU	Hungary	NZ	New Zealand
BJ	Benin	IE	Ireland	PL	Poland
BR	Brazil	IT	Italy	PT	Portugal
BY	Belarus	JP	Japan	RO	Romania
CA	Canada	KP	Democratic People's Republic of Korea	RU	Russian Federation
CF	Central African Republic	KR	Republic of Korea	SD	Sudan
CG	Congo	KZ	Kazakhstan	SE	Sweden
CH	Switzerland	LI	Liechtenstein	SI	Slovenia
CI	Côte d'Ivoire	LK	Sri Lanka	SK	Slovak Republic
CM	Cameroon	LU	Luxembourg	SN	Senegal
CN	China	LV	Latvia	TD	Chad
CS	Czechoslovakia	MC	Monaco	TG	Togo
CZ	Czech Republic	MG	Madagascar	UA	Ukraine
DE	Germany	ML	Mali	US	United States of America
DK	Denmark	MN	Mongolia	UZ	Uzbekistan
ES	Spain			VN	Viet Nam
FI	Finland				

MANUFACTURE OF HELICALLY CORRUGATED CONDUITBACKGROUND OF THE INVENTION

This invention relates to the manufacture of helically corrugated conduits and conduits made by that method such as heat exchange conduits used to exchange heat from one fluid to another, in liquid to gas, gas to gas or liquid to liquid heat exchange and also the drying of powders or any other uses where a helical spiralled tube is of assistance such as electrical element housing tube.

A number of conduits incorporating a helical spiral or even a multi-start helix in the wall of the conduit are known. Such tubes or conduits are variously described in apparatus in specification numbers GB1511718, GB2374609, US3730229 and US4559999.

Of these specifications, only US3730229 goes into some detail on the method of manufacture of such a conduit. The method disclosed in that specification involves creating indentations in the tube to act as starting points for the helical spiral and then the simultaneous twisting and longitudinal compression of the tube over an internal mandrel and within an exterior tube. Such a method is both complex, time consuming and can lead to the twisted helical conduit being jammed within the outer tube.

Both this prior art method of manufacture and others suggested by twisting the conduit can lead to conduits of uneven wall thickness and uneven stresses within the finish conduit. This can lead to breakage during manufacture and failure of the conduit in use.

OBJECTS OF THE INVENTION

It is thus an object of the present invention to provide a method of manufacture of a helically corrugated conduit and a conduit so manufactured with a relatively constant wall thickness and/or which is more economic than the prior art methods.

It is a further object of this invention to provide a helically corrugated conduit and a method of manufacture of said heat helically corrugated conduit which comes some way in overcoming the abovementioned problems or at least will provide the public with a useful choice. Other objects of this invention will become apparent from the following description.

SUMMARY OF THE INVENTION

According to a first aspect of this invention, there is provided a method of manufacturing a helically corrugated conduit incorporating at least one helical undulation thereon and including the steps of:

- i) positioning a portion of substantially smooth walled tube formed in a malleable material on a support means
- ii) positioning at least one forming wheel with at least its outer periphery in contact with a surface of said tube with the axis of said wheel mounted at an angle relative to a longitudinal axis of said tube; and
- iii) rotating said tube and/or forming wheel one relative to the other to form a wave of material from a wall portion of said tube adjacent said forming wheel to longitudinally undulate a portion of said tube wall substantially helically.

Accordingly, in a second aspect, the invention consists in a method of forming a smooth walled tubular conduit of formable material into a conduit incorporating at least one helical spiral in the wall of a longitudinal portion of said conduit by cold rolled forming.

Accordingly, in a third aspect, the invention consists in a method of manufacturing a heat exchange conduit from a smooth walled tube of formable material comprising the steps of:

- i) progressing said tube along a support means supporting said tube;

- ii) engaging a portion of the outer periphery of at least one forming wheel with said tube;
- iii) rotating said tube or said forming wheel or both one with respect to the other; and
- iv) wherein said tube is progressed against said forming wheel under a pressure such that said forming wheel forms a helical spiral in the wall of said tube to form said conduit.

Modifications are envisaged and may be incorporated without departing from the scope or spirit thereof.

BRIEF DESCRIPTION OF THE DRAWINGS

One form of the invention will now be described in relation to the accompanying drawings in which:

Figure 1 is a partial cutaway substantially diagrammatic side view of one embodiment of the conduit of this invention.

Figure 2 is a diagrammatic end view of the conduit of Figure 1.

Figure 3 is a substantially diagrammatic cross-sectional side view of a further embodiment of a portion of conduit.

Figure 4 is a similar view to that of Figure 3 showing a still further embodiment of conduit.

Figure 5 is a similar view to that of Figures 3 and 4 showing a still further embodiment of conduit.

Figure 6 is a substantially diagrammatic side view of an apparatus for manufacturing the conduit in one embodiment.

Figure 7 is a substantially diagrammatic cross-sectional side view of a portion of the forming head of the apparatus of Figure 6.

Figure 8 is a substantially diagrammatic end view of the forming head of Figure 7 viewed substantially longitudinally of the apparatus of Figure 5.

DESCRIPTION OF PREFERRED EMBODIMENTS

With reference to the drawings, in the preferred form of the invention, the conduit as generally indicated by arrow 1 is preferably formed in a thermally conductive material such as metal; for example copper, stainless steel, aluminium and the like, being

preferably a substantially malleable or formable material if it is to be used as a heat exchange conduit. Other materials for heat exchange or other uses may be substituted. It is possible to use the method on plastic tubing and also plastic lined tubing. The forming method can form the plastic lining with the tubing in one operation.

With particular reference to Figures 1 to 5, a heat exchange conduit 1 produced by the method of manufacture is in the preferred form from substantially smooth walled copper tube and is arranged along at least a portion of the length of the tube to have a substantially helically ribbed portion as generally indicated by arrow 2.

It will be appreciated that the undulations substantially increase the surface area to length ratio of the tube over the substantially smooth walled tube and enhance the thermal-conductivity of the tube relative to its length in view of the increase in surface area.

The heat exchange conduit 1 is preferably provided with undulations which have outer ribs 3 thereof which project outwardly of a general peripheral line of the tube from which the heat exchange conduit 1 is made. The undulations are each preferably defined as a plurality of helical ribs 3 extending about and

longitudinally of the conduit 1 coupled with an associated groove 4 which, in this preferred form extends inwardly into the interior of the tube to define a plurality of internal ribs 5 therein.

In the preferred form of the invention, the extent of outward projection of the ribs 3 is substantially commensurate with an outer preferred diameter of the finished heat exchange conduit 1.

Preferably the inner ribs 5 are such that they are substantially commensurate with a normal inner diameter of the tube from which the heat exchange conduit 1 is formed. In this way, it will be appreciated that the formation of the conduit 1 does not reduce its cross-sectional area and perhaps create an undue restriction therein. Internal grooves 6 defined between the internal ribs 5 enable a flow of fluid through the interior of the conduit passageway to extend into the ribs 3, to provide a high ratio of surface area to length of the tube conduit 1 and good heat transfer properties therein, as fluid flows through the passageway of the conduit.

In the preferred form of the invention, preferably the helical ribbing 3 of the tube to provide the conduit 1 is provided as a plurality (preferably four) of

helical ribs 3 each commencing in a similar longitudinal position relative to said tube, substantially diametrically opposed one relative to the other so as to provide a form substantially known in the trade as "multistart" helixes.

Referring now to Figures 3, 4 and 5, it is envisaged that the conduit 1 and its undulations can be alternatively formed. By way of example only, Figure 3 shows substantially cross-sectionally a portion of a wall of a conduit 1 which is particularly suited to gas-to-fluid heat exchange. The gas is positioned externally of the conduit 1, and with the undulations, being closely defined leaving only a small groove for liquid with an enhanced surface area to length ratio over the form of Figure 1. Such an arrangement would be particularly suited to motor vehicles radiators, space heating apparatus and refrigerator condenser cores.

With reference to Figure 4, it is envisaged that in certain instances, such as where greater need for prevention of "streaming" is required, that the undulating portions of the conduit 1 can be provided and positioned so that internal ribs 5 thereof are mounted substantially inwardly, out of register with remaining portions of the tube, from which the conduit 1 is formed. It will be appreciated that this causes an

increased interference to the flow of the fluid through the conduit 1, and a greater turbulating action to the fluid passing therethrough as a result.

In the preferred form of the invention, a flow of fluid through the passageway of the conduit is preferably in the direction of arrow F as is shown by Figures 1 to 5. It will be appreciated that with a flow in this direction, and with the particular shape of the associated ribs 5 and recesses 6 internally thereof, there is an enhanced tendency for fluid to flow into the recesses 6 and turbulate, swirl or rotate therein as it flows through the passageway.

It is to be appreciated that a varying of the shape of the undulations may enable more efficient flow from a substantially opposite direction from that described and therefore the invention is not limited to the flow direction as shown and described with reference to Figures 1 to 5.

It is envisaged that each piece of conduit will be provided with a short spigot portion preferably adjacent each end thereof formed in substantially smooth walled tube, to thus facilitate the convenient connection of such conduits with other portions of apparatus utilising substantially known fittings and techniques.

The conduit 1 may be used as an electrical element housing tube within water heaters such as kettles or cylinders.

Now turning to Figures 6, 7 and 8, a method of forming the conduit 1 will be described.

With reference to Figures 6, 7 and 8, and in particular Figure 6, it is to be appreciated that the conduit 1 is preferably formed from tubular metal material, such as copper, which is provided in substantially selected lengths and is positioned in a magazine 100. The magazine 100 is arranged by rollers 101 and associated selection means (not shown) to progressively feed a single length of smooth walled tubular material into drive rollers 102 mounted between the magazine 100 and a cutoff means 103 adjacent a forming head 104. The drive rollers 102 in the preferred form of the invention preferably drive the selected length of tubular material through the forming head 104 whereupon the undulating form of the conduit 1 is cold roll-formed thereon as said tube positions and is pushed over an elongate mandrel means 105 which extends from a remote stop portion 106.

If only a shallow corrugation is required, it is possible to dispense with the mandrel and support the tubing on other support means such as rollers.

Preferably suitable actuating means and stop means are provided adjacent the mandrel stop, drive rollers, cut off means and the like so as to enable a sequence operation to occur and enable substantially automated production of the conduit 1 according to a predetermined design.

Turning now particularly to Figures 7 and 8, the forming head 104 of Figure 6 in the preferred form of the invention preferably includes a plurality of diametrically arranged forming wheels 107 each radially arranged relative to the mandrel 105 of the forming head 104.

Preferably, each forming wheel is mounted substantially as is shown by Figure 7, at an angle and with its rotational axis inclined relative to the longitudinal axis of the mandrel and therefore the conduit 1 positioned thereon.

Adjustment of the angle of the forming wheel 107 can change the pitch and depth of the corrugations in the finished conduit.

Preferably peripheral portions 109 of the each wheel 107 are each so shaped to engage with outer surfaces of the tube from which the conduit 1 is formed and to run thereon said wheels 107 are each mounted substantially out of line with a normal rolling run of said periphery 109 so that when the tube is positioned over said mandrel 105 and said roller 107 periphery 109 is brought into contact with exterior surface of the tube, a "wave" of material is developed downstream of said roller 107 and a surface of the tube is formed into the undulations described hereinbefore in relation to Figures 1 to 5 upon the relative rotation of said tube and said wheels 107.

It will be appreciated that the rollers 107 are each mounted to move to and from the operative position to enable feeding of the tube onto the mandrel 105 end prior to formation. It is also to be appreciated that the drive rollers 102 in the preferred form of the invention provide a sufficient degree of pressure P in the direction of arrow P of Figures 6 and 7 so that the "wave" of tube material is formed by each of the rollers or wheels 107 as the drive rollers 102 force the tubular material over the mandrel 105 and maintain pressure against the rollers 107. The pressure required will vary according to the type of material used, the thickness of the wall of the tubing and the corrugation desired.

It will be appreciated that by this method a substantially quadruple start helix is provided on the conduit. It should be appreciated that as many "starts" as may be required may be provided, subject to sufficient rollers 107 being able to be arranged substantially radially of the mandrel 105 and in the forming head 104. In some instances, particularly with larger tubing, it may be desirable to use more than one forming wheel to form each helical spiral. For example, eight forming wheels for a four start helix.

The conduit resulting from this method of manufacture comprises a conduit of relatively uniform wall thickness through the cold rolled forming of the helical spirals. The spirals are created to form a finished conduit of shorter length than the length of initial smooth walled tube used in its creation. Other methods of manufacture may create uneven wall thicknesses and perhaps an uneven distribution of stresses throughout the finished conduit.

Thus, by this invention, there is provided an improved method of manufacture of a helically corrugated conduit providing for economic manufacture of a conduit incorporating a relatively simple design and a high ratio of surface area to length.

CLAIMS

1. A method of manufacturing a helically corrugated conduit incorporating at least one helical undulation thereon and including the steps of:
 - i) positioning a portion of substantially smooth walled tube formed in a malleable material on a support means;
 - ii) positioning at least one forming wheel with at least its outer periphery in contact with the surface of said tube with the axis of said wheel mounted at an angle relative to a longitudinal axis of said tube; and
 - iii) rotating said tube and/or forming wheel 1 relative to the other to form a wave of material from a wall portion of said tube adjacent said forming wheel to longitudinally undulate a portion of said tube wall substantially helically.

2. A method of manufacturing a helically corrugated conduit as claimed in Claim 1 wherein said tube or forming wheel is moved to traverse a substantial portion of the length of said tube.

3. A method of manufacturing a helically corrugated conduit as claimed in Claim 1 or Claim 2

wherein a multiplicity of forming wheels are positioned about the circumference of said tube to form a multiplicity of helical spirals.

4. A method of manufacturing a helically corrugated conduit as claimed in Claim 3 wherein said multiplicity of forming wheel comprises four forming wheels.
5. A method of manufacturing a helically corrugated conduit as claimed in any one of the preceding claims wherein a portion of said smooth walled tube is unformed adjacent an end of said tube.
6. A method of manufacturing a helically corrugated conduit from a smooth walled tube of formable material comprising the steps of:
 - i) progressing said tube along a support means supporting said tube;
 - ii) engaging a portion of the outer periphery of at least one forming wheel with said tube;
 - iii) rotating said tube or said forming wheel or both one with respect to the other; and
 - iv) wherein said tube is progressed against said forming wheel under a pressure such that said forming wheel forms a helical spiral in the wall of said tube to form said conduit.

7. A method of manufacturing a helically corrugated conduit as claimed in Claim 6 wherein said tube is progressed towards said forming wheel by driving means.
8. A method of manufacturing a helically corrugated conduit as claimed in Claim 7 wherein said driving means comprise drive rollers.
9. A method of manufacturing a helically corrugated conduit as claimed in any one of Claims 6 to 8 wherein a multiplicity of forming wheels are positioned about the circumference of said tube to form a multiplicity of helical spirals.
10. A method of manufacturing a helically corrugated conduit as claimed in any one of Claims 6 to 9 wherein said multiplicity of forming wheels comprises four forming wheels.
11. A method of manufacturing a helically corrugated conduit as claimed in any one of Claims 6 to 10 wherein a portion of said smooth walled tube is unformed adjacent an end of said tube.

12. A method of manufacturing a helically corrugated conduit as claimed in any one of Claims 6 to 11 wherein said support means comprise a cylindrical mandrel positioned within said tube.
13. A method of forming a smooth walled tubular conduit of formable material into a conduit incorporating at least one helical spiral in the wall of a longitudinal portion of said conduit by cold rolled forming.
14. A helically corrugated conduit manufactured by any one of the methods of Claims 1 to 13.
15. A method of manufacturing a helically corrugated conduit substantially as hereinbefore described with reference to the accompanying drawings.
16. A helically corrugated conduit substantially as hereinbefore described with reference to the accompanying drawings.

1/3

FIG.2.

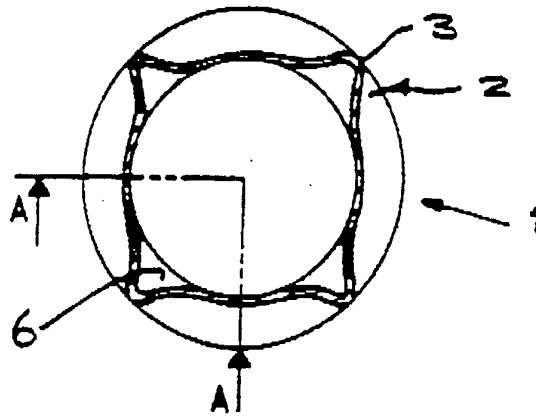
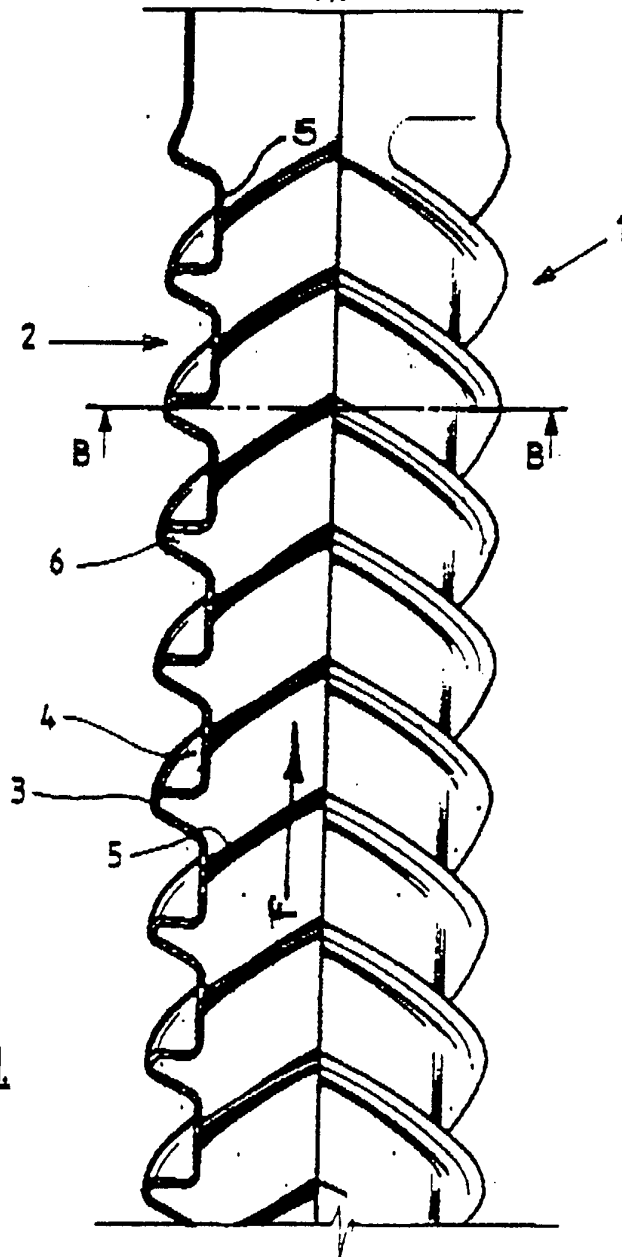

FIG.1.



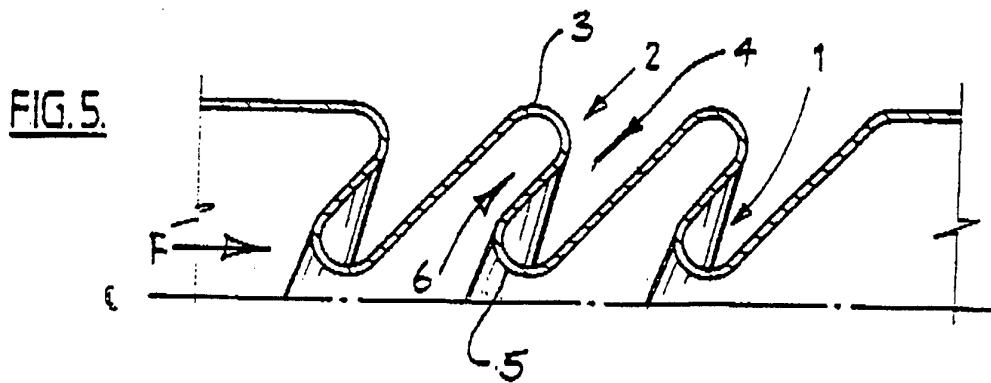
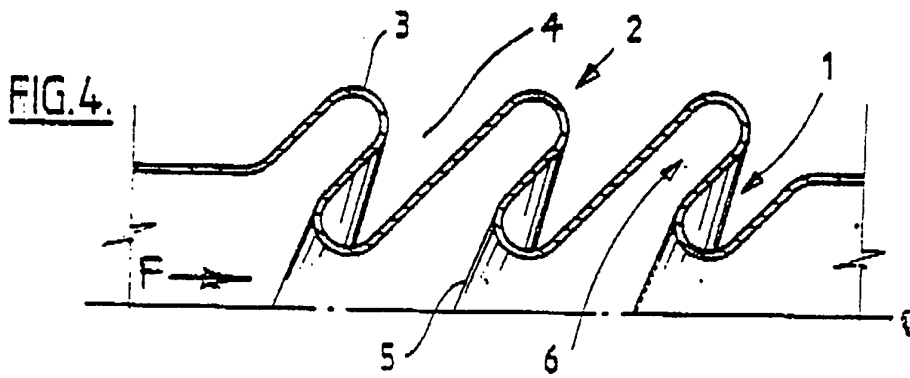
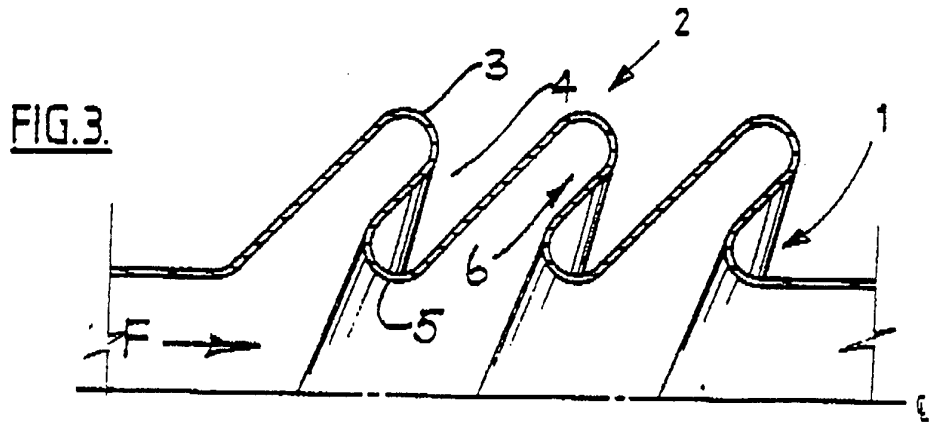

FIG. 6.

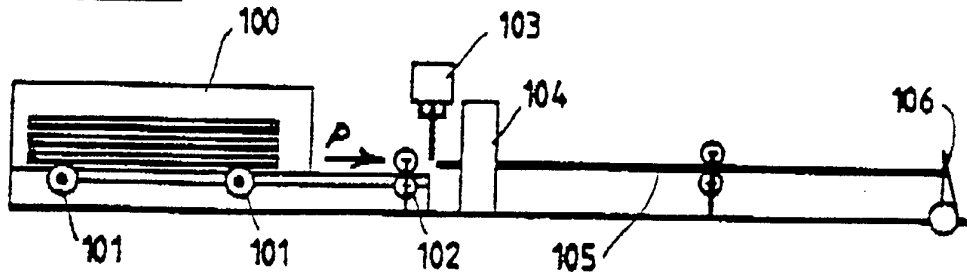

FIG. 7.

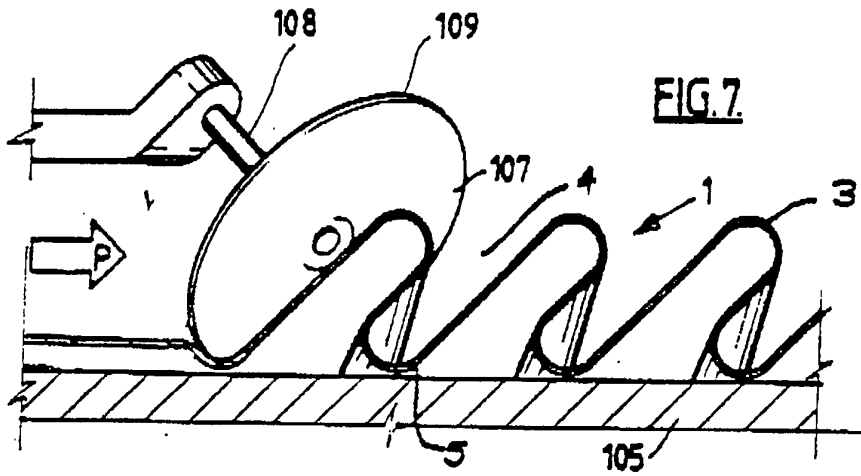
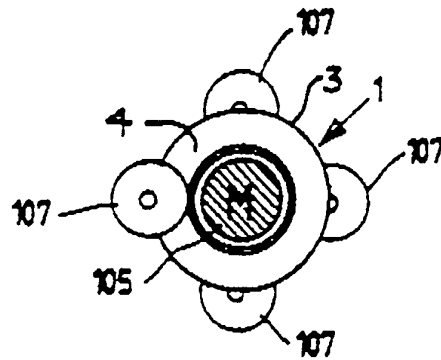
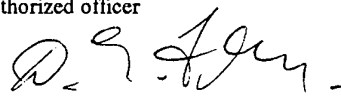

FIG. 8.



A. CLASSIFICATION OF SUBJECT MATTER Int. Cl. ⁵ F16L 9/06, B21D 15/04, F28D 7/02 According to International Patent Classification (IPC) or to both national classification and IPC													
B. FIELDS SEARCHED Minimum documentation searched (classification system followed by classification symbols) IPC F16L 9/06, B21D 15/04, F28D 7/02 Documentation searched other than minimum documentation to the extent that such documents are included in the fields searched AU:IPC as above Electronic data base consulted during the international search (name of data base, and where practicable, search terms used)													
C. DOCUMENTS CONSIDERED TO BE RELEVANT													
<table border="1"> <thead> <tr> <th>Category *</th> <th>Citation of document, with indication, where appropriate, of the relevant passages</th> <th>Relevant to Claim No.</th> </tr> </thead> <tbody> <tr> <td>X</td> <td>DERWENT SOVIET INVENTIONS ILLUSTRATED, GENERAL ENGINEERING, P39, SU 239185 (VAINER & OVSIANNIKOV) 21 JULY 1969 (21.7.69) Abstract & Figure</td> <td>1 & 6</td> </tr> <tr> <td>X</td> <td>US,A,3,732,717 (AHLVERS) 15 MAY 1973 (15.5.73) Column 2, lines 11 to 20 & Figure 1</td> <td>1 & 6</td> </tr> <tr> <td>X</td> <td>US,A,3,606,780 (NAGAHARA) 21 SEPTEMBER 1971 (21.9.71) Abstract & Figures</td> <td>1 & 6</td> </tr> </tbody> </table>	Category *	Citation of document, with indication, where appropriate, of the relevant passages	Relevant to Claim No.	X	DERWENT SOVIET INVENTIONS ILLUSTRATED, GENERAL ENGINEERING, P39, SU 239185 (VAINER & OVSIANNIKOV) 21 JULY 1969 (21.7.69) Abstract & Figure	1 & 6	X	US,A,3,732,717 (AHLVERS) 15 MAY 1973 (15.5.73) Column 2, lines 11 to 20 & Figure 1	1 & 6	X	US,A,3,606,780 (NAGAHARA) 21 SEPTEMBER 1971 (21.9.71) Abstract & Figures	1 & 6	<input type="checkbox"/> Further documents are listed in the continuation of Box C.
Category *	Citation of document, with indication, where appropriate, of the relevant passages	Relevant to Claim No.											
X	DERWENT SOVIET INVENTIONS ILLUSTRATED, GENERAL ENGINEERING, P39, SU 239185 (VAINER & OVSIANNIKOV) 21 JULY 1969 (21.7.69) Abstract & Figure	1 & 6											
X	US,A,3,732,717 (AHLVERS) 15 MAY 1973 (15.5.73) Column 2, lines 11 to 20 & Figure 1	1 & 6											
X	US,A,3,606,780 (NAGAHARA) 21 SEPTEMBER 1971 (21.9.71) Abstract & Figures	1 & 6											
<input checked="" type="checkbox"/> See patent family annex.													
* Special categories of cited documents : "A" document defining the general state of the art which is not considered to be of particular relevance "E" earlier document but published on or after the international filing date "L" document which may throw doubts on priority claim(s) or which is cited to establish the publication date of another citation or other special reason (as specified) "O" document referring to an oral disclosure, use, exhibition or other means "P" document published prior to the international filing date but later than the priority date claimed	"T" later document published after the international filing date or priority date and not in conflict with the application but cited to understand the principle or theory underlying the invention "X" document of particular relevance; the claimed invention cannot be considered novel or cannot be considered to involve an inventive step when the document is taken alone "Y" document of particular relevance; the claimed invention cannot be considered to involve an inventive step when the document is combined with one or more other such documents, such combination being obvious to a person skilled in the art "&" document member of the same patent family												
Date of the actual completion of the international search 23 DECEMBER 1993 (23.12.93)	Date of mailing of the international search report 12 JAN 1994 (12.01.94)												
Name and mailing address of the ISA/AU AUSTRALIAN INDUSTRIAL PROPERTY ORGANISATION PO BOX 200 WODEN ACT 2606 AUSTRALIA Facsimile No. 06 2853929	Authorized officer  D. G. FRY Telephone No. (06) 2832130												

C(Continuation). DOCUMENTS CONSIDERED TO BE RELEVANT		
Category*	Citation of document, with indication, where appropriate of the relevant passages	Relevant to Claim No.
A	GB,A,1,326,320 (FELTEN & GUILLEAUME KABELWERKE AKTIENGESELLSCHAFT) 8 AUGUST 1973 (8.8.73) ENTIRE DOCUMENT	1 & 6
A	GB,A,1,365,039 (SPIRAL TUBING CORPORATION) 29 AUGUST 1974 (29.8.74) ENTIRE DOCUMENT	1 & 6

This Annex lists the known "A" publication level patent family members relating to the patent documents cited in the above-mentioned international search report. The Australian Patent Office is in no way liable for these particulars which are merely given for the purpose of information.

Patent Document Cited in Search Report		Patent Family Member					
US	3732717	CA	961706	DE	2049235	FR	2112264
		GB	1311445				
END OF ANNEX							