

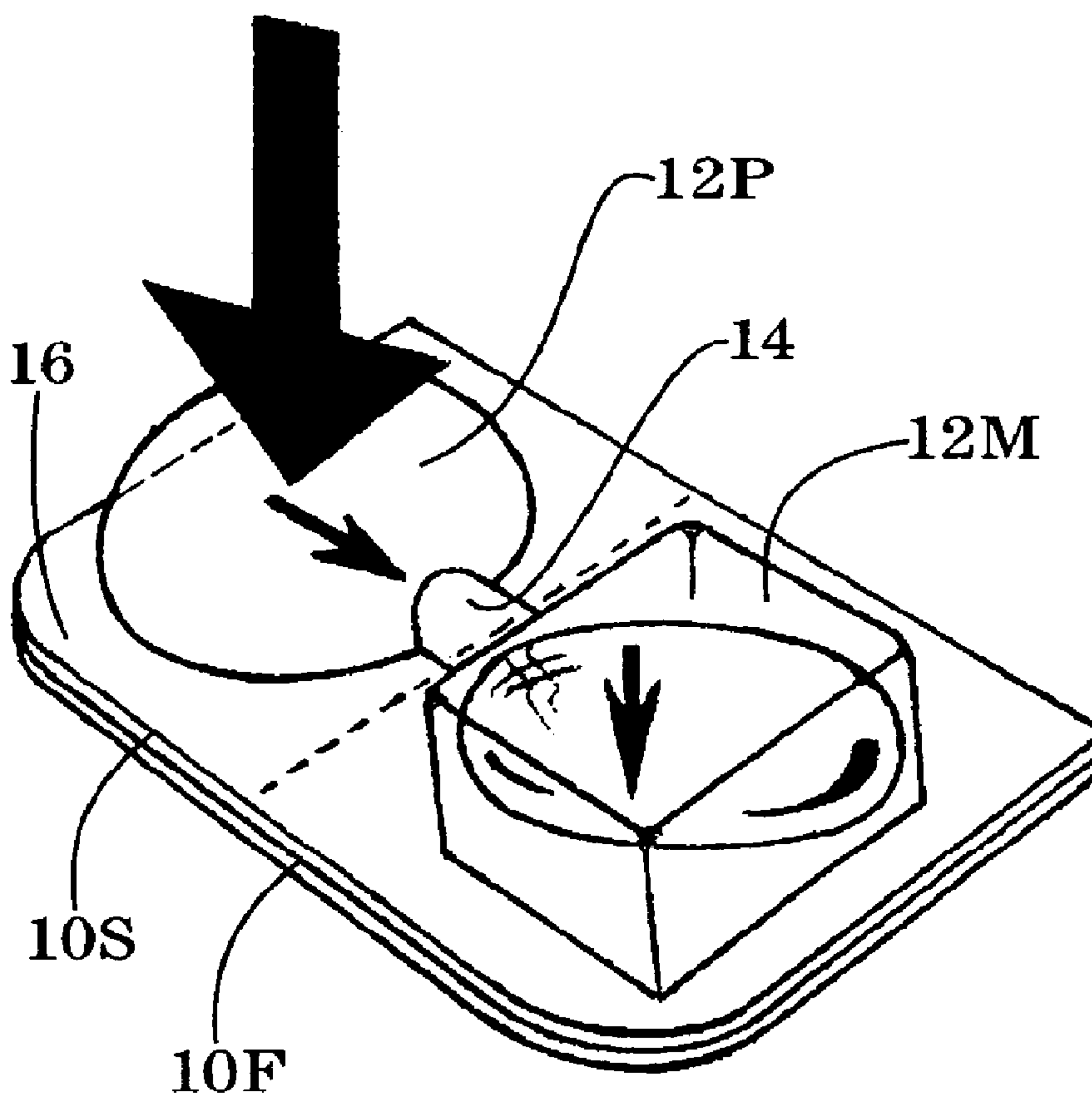

(86) Date de dépôt PCT/PCT Filing Date: 2007/04/10
 (87) Date publication PCT/PCT Publication Date: 2007/10/18
 (45) Date de délivrance/Issue Date: 2014/11/04
 (85) Entrée phase nationale/National Entry: 2008/10/09
 (86) N° demande PCT/PCT Application No.: EP 2007/053475
 (87) N° publication PCT/PCT Publication No.: 2007/116065
 (30) Priorités/Priorities: 2006/04/10 (US60/790,483);
 2007/04/02 (US11/731,705)

(51) Cl.Int./Int.Cl. *B65D 75/36* (2006.01)
 (72) Inventeur/Inventor:
 PERELL, WILLIAM S., US
 (73) Propriétaire/Owner:
 POPPACK LLC, US
 (74) Agent: MARKS & CLERK

(54) Titre : UNITE DE DISTRIBUTION DE PRODUIT SCELLEE POURVUE D'UNE POMPE DE RUPTURE
 (54) Title: SEALED PRODUCT DELIVERY UNIT WITH RUPTURING PUMP



(57) Abrégé/Abstract:

Sealed delivery unit 10 contains medication 10M, and is formed by a generally flat member 10F pressed into selective engagement with an opposed shaped member 10S. Pumping chamber 12P, enclosed between the members generates a rupturing pressure in

(57) **Abrégé(suite)/Abstract(continued):**

response to an external force applied by the user Enclosed Medication chamber 12M contains the medication to be delivered. Tunnel conduit 14 provides fluid communication between the chambers for rupturing the medication chamber in response to the rupturing pressure. Perimeter seal 16 extends around the pumping chamber and the medication chamber and the tunnel conduit. The perimeter seal is secure enough to withstand the internal rupturing pressure generated during delivery. Delivery port 18 with pull-away closure 18C (see FIG. 1C) delivers the medication out of medication chamber 12M. Rupture site 18S is proximate the delivery port. Rupture flap 18F produced by the rupturing at the rupture site, is connected to the pull-away closure. The flap projects outward permitting the user to grasp the pull-away the closure and open the delivery port for delivery of the medication.

(12) INTERNATIONAL APPLICATION PUBLISHED UNDER THE PATENT COOPERATION TREATY (PCT)

(19) World Intellectual Property Organization
International Bureau(43) International Publication Date
18 October 2007 (18.10.2007)

PCT

(10) International Publication Number
WO 2007/116065 A1(51) International Patent Classification:
B65D 75/36 (2006.01)(21) International Application Number:
PCT/EP2007/053475

(22) International Filing Date: 10 April 2007 (10.04.2007)

(25) Filing Language: English

(26) Publication Language: English

(30) Priority Data:
60/790,483 10 April 2006 (10.04.2006) US
11/731,705 2 April 2007 (02.04.2007) US(71) Applicant (for all designated States except US): **POP-
PACK LLC** [US/US]; 301 Junipero Serra Blvd, Suite 220,
San Francisco, California 94127-2614 (US).(71) Applicant (for BB only): **GREY, Ian** [GB/GB]; 20 Little
Britain, London EC1A 7DH (GB).

(72) Inventor; and

(75) Inventor/Applicant (for US only): **PERELL, William
S.** [US/US]; 157 Lunado Way, San Francisco, California
94127-2845 (US).(74) Agents: **GREY, Ian** et al.; Venner Shipley LLP, 20 Little
Britain, London EC1A 7DH (GB).(81) Designated States (unless otherwise indicated, for every
kind of national protection available): AE, AG, AL, AM,
AT, AU, AZ, BA, BB, BG, BH, BR, BW, BY, BZ, CA, CH,
CN, CO, CR, CU, CZ, DE, DK, DM, DZ, EC, EE, EG, ES,
FI, GB, GD, GE, GH, GM, GT, HN, HR, HU, ID, IL, IN,
IS, JP, KE, KG, KM, KN, KP, KR, KZ, LA, LC, LK, LR,
LS, LT, LU, LY, MA, MD, MG, MK, MN, MW, MX, MY,
MZ, NA, NG, NI, NO, NZ, OM, PG, PH, PL, PT, RO, RS,
RU, SC, SD, SE, SG, SK, SL, SM, SV, SY, TJ, TM, TN,
TR, TT, TZ, UA, UG, US, UZ, VC, VN, ZA, ZM, ZW.(84) Designated States (unless otherwise indicated, for every
kind of regional protection available): ARIPO (BW, GH,
GM, KE, LS, MW, MZ, NA, SD, SL, SZ, TZ, UG, ZM,
ZW), Eurasian (AM, AZ, BY, KG, KZ, MD, RU, TJ, TM),
European (AT, BE, BG, CH, CY, CZ, DE, DK, EE, ES, FI,
FR, GB, GR, HU, IE, IS, IT, LT, LU, LV, MC, MT, NL, PL,
PT, RO, SE, SI, SK, TR), OAPI (BF, BJ, CF, CG, CI, CM,
GA, GN, GQ, GW, ML, MR, NE, SN, TD, TG).

Published:

— with international search report

[Continued on next page]

(54) Title: SEALED PRODUCT DELIVERY UNIT WITH RUPTURING PUMP

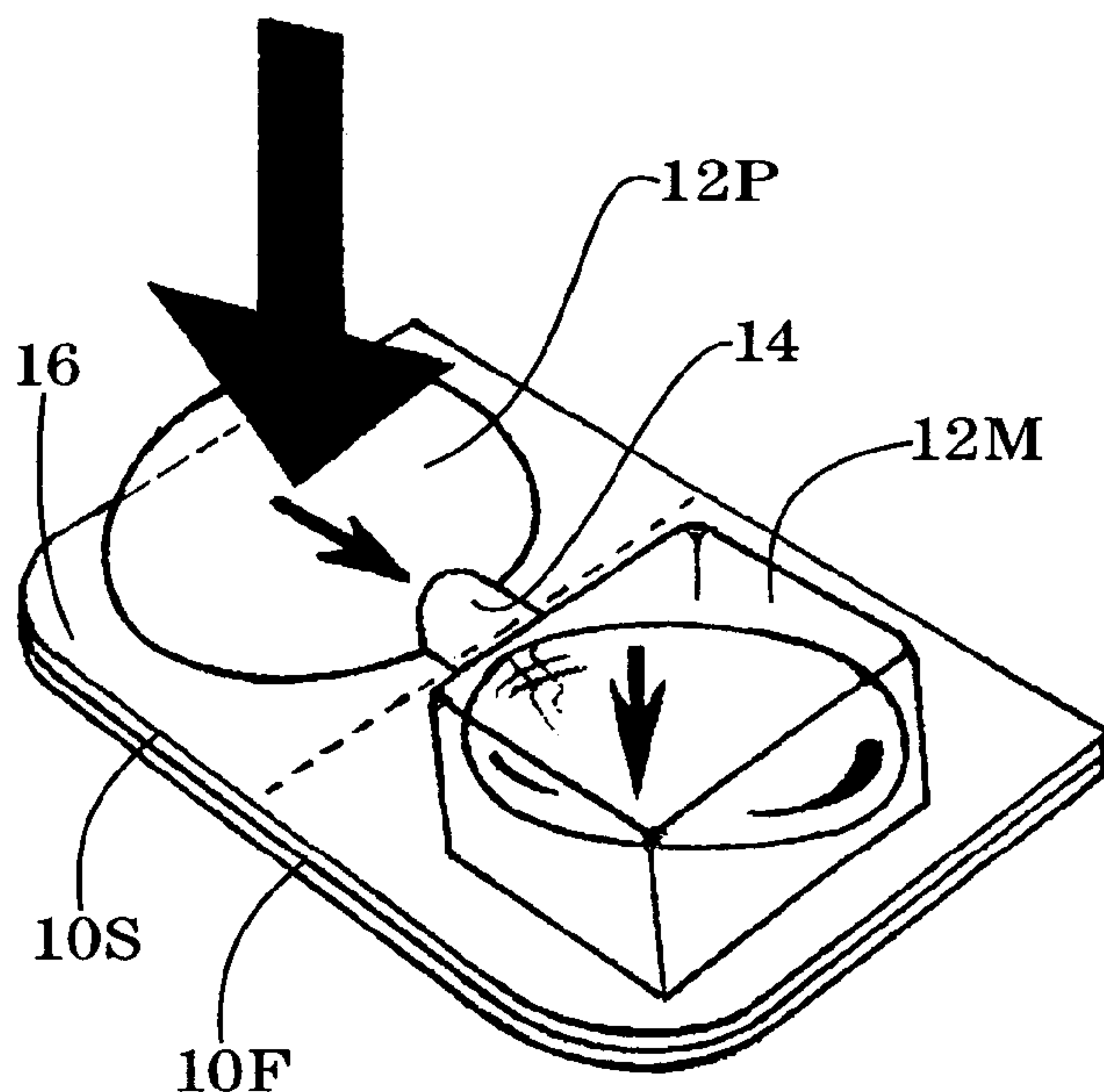

(57) **Abstract:** Sealed delivery unit 10 contains medication 10M, and is formed by a generally flat member 10F pressed into selective engagement with an opposed shaped member 10S. Pumping chamber 12P, enclosed between the members generates a rupturing pressure in response to an external force applied by the user. Enclosed Medication chamber 12M contains the medication to be delivered. Tunnel conduit 14 provides fluid communication between the chambers for rupturing the medication chamber in response to the rupturing pressure. Perimeter seal 16 extends around the pumping chamber and the medication chamber and the tunnel conduit. The perimeter seal is secure enough to withstand the internal rupturing pressure generated during delivery. Delivery port 18 with pull-away closure 18C (see FIG. 1C) delivers the medication out of medication chamber 12M. Rupture site 18S is proximate the delivery port. Rupture flap 18F produced by the rupturing at the rupture site, is connected to the pull-away closure. The flap projects outward permitting the user to grasp the pull-away the closure

and open the delivery port for delivery of the medication.

WO 2007/116065 A1

WO 2007/116065 A1



For two-letter codes and other abbreviations, refer to the "Guidance Notes on Codes and Abbreviations" appearing at the beginning of each regular issue of the PCT Gazette.

SEALED PRODUCT DELIVERY UNIT
WITH RUPTURING PUMP

5

10

TECHNICAL FIELD

15 This invention relates to a product delivery unit,
and more particularly to a sealed unit with a pump for
generating a seal rupturing pressure.

BACKGROUND

20 Heretofore, medications were packaged in flat packs
between a transparent blister cover and a stiff material
with a thin foil seal. Multiple medications were
presented in a matrix array in a single rectangular pack.
The end-user could see the medication through the blister
25 cover, and push the medication down through the base and
foil, and out the bottom of the pack. The user had to use
enough force to puncture the base material and split
through the foil. The pushing force was applied directly
on the transparent cover and conveyed down onto the
30 medication. Sometimes the conveyed force crushed the
pill, or broke the jacket of a capsule. The medication
commonly "hung-up" on the rough edges around the exit
puncture. The user had to pick at the exit edges and the
medication, causing further damage to the medication. The
35 manual dexterity required for pushing and extracting the
medication was frequently difficult for the aged.

SUMMARY

5 It is therefore an object of this invention to provide a product delivery unit in which no user force or other pushing coercion is applied directly on the product during delivery. The user does not push or force the product out of the unit. The product falls out through a delivery port after the user ruptures the product chamber and clears the port by pulling away a removable port closure. The user applies force directly onto an adjacent 10 pumping chamber to compress air which generates the rupturing pressure.

15 It is another object of this invention to provide such a sealed delivery unit for medications which does not require touching or handling the medication until after delivery. The medication drops directly into the hand of the end-user or into a dispensing container such as a disposable cup.

20 It is a further object of this invention to provide such a delivery unit having an opening procedure that is easily understood and executed by the aged, but difficult for young children. Adults can readily survey the physical lay-out of the delivery unit, comprehend the procedure, and press to generate the compressed air. 25 Children on the other hand, go directly for the colored medication and struggle with the hard transparent cover.

30 It is a further object of this invention to provide such a delivery unit which assists the user in dislodging medications hung-up on the rough exit edges. Compressed air from the pumping chamber supplies an air stream that carries the smooth medication out the exit site.

35 It is a further object of this invention to provide a medication delivery system having multiple delivery

units, in which the disturbance of adjacent non-delivering units is minimized.

Briefly, these and other objects of the present invention are accomplished by providing sealed unit for delivering a product or medication in response to a rupturing pressure. The unit has a generally flat member and an opposed shaped member pressed into selective engagement therewith. A pumping chamber enclosed between the members generates the rupturing pressure in response to an externally applied force. A medication chamber also enclosed contains the medication to be delivered. Fluid communication between the chambers permits rupturing the medication chamber in response to the rupturing pressure. A perimeter seal formed during the selective pressing engagement, extends around the chambers and can withstand the rupturing pressure. A delivery port with a pull-away closure delivers the medication out of the medication chamber. A rupture site proximate the delivery port ruptures outward under the rupturing pressure. A rupture flap produced by the rupturing and connected to the pull-away closure, permits the user to pulling away of the pull-away closure to open the delivery port for delivery of the medication.

25

According to one aspect of the invention there is provided a sealed unit for delivering a product in response to a rupturing pressure, comprising:

a generally flat member;

30

a shaped member opposed to the flat member, and pressed into selective engagement with the flat member, wherein a pumping volume is enclosed between the flat member and the opposed shaped member for generating the rupturing pressure in response to an externally applied

35

force;

3a

a product volume enclosed between the flat member and the opposed shaped member for containing the product to be delivered;

5 a fluid communication between the pumping volume and the product volume permits the rupturing the product volume in response to the rupturing pressure from the pumping volume;

a product contained in the product volume;

10 a perimeter seal formed during the selective pressing engagement, and extending around the pumping volume and the product volume, which perimeter seal can withstand the rupturing pressure;

a delivery port with a pull-away closure for delivering the product out of the product volume, wherein a
15 rupture site proximate the delivery port ruptures outward under the rupturing pressure; and

a rupture flap produced by the rupturing at the rupture site, and connected to the pull-away closure, permitting pulling away of the pull-away closure to open
20 the delivery port for delivery of the product contained within the product volume.

According to a further aspect of the invention there is provided a sealed system for delivering medications in
25 response to a rupturing pressure, comprising:

a flat member;

a shaped member opposed to the flat member, and pressed into selective engagement with the flat member;

30 a plurality of delivery units enclosed between the flat member and the opposed shaped member;

a pumping chamber within each delivery unit for generating the rupturing pressure;

a medication chamber within each delivery unit for containing the medication to be delivered;

35 a fluid communication between the pumping chamber and the medication chamber, for communicating the rupturing

3b

pressure from that pumping chamber to the medication chamber;

a medication contained in each medication chamber;

5 a perimeter seal formed during the selective pressing engagement to withstand the rupturing pressure, and extending around the delivery units for sealing the pumping chambers and the medication chambers;

10 a delivery port with a pull-away closure out of each medication chamber for delivering the medications in the sealed medication chambers;

a rupture site proximate each delivery port which ruptures outward under the rupturing pressure; and

15 a rupture flap produced by the rupturing of the rupture site, and connected to the pull-away closure, permitting pulling away of the pull-away closure to open the delivery port for delivery of the medication contained in the medication chambers.

BRIEF DESCRIPTION OF THE DRAWINGS

20 Further objects and advantages of the present delivery unit and the operation of the pumping chamber will become apparent from the following detailed description and drawings (not drawn to scale) in which:

25 **FIG. 1A** is an exploded perspective view of delivery unit **10** showing medication chamber **12M** and pumping chamber **12P**;

FIG. 1B is a perspective view of delivery unit 10 of FIG. 1A, showing external pressure applied to pumping chamber 12P;

5 FIG. 1C is a perspective view of the back side of delivery unit 10 of FIG. 1A showing open delivery port 18 and pull-away closure 18C with medication 10M exiting from medication chamber 12M;

10 FIG. 2A is a front view of delivery system 20 having multiple delivery units 20U, each with a medication chamber 22M and a pumping chamber 22P;

15 FIG. 2B is a back view of delivery system 20 of FIG. 2A showing multiple delivery ports 28;

FIG. 3 is a plan view of delivery unit 30 with medication 30M and rupturing site 38S within common chamber 30C; and

20 FIG. 4 is a side view of coplanar delivery unit 40 being opened on a flat surface.

25 The first digit of each reference numeral in the above figures indicates the figure in which an element or feature is most prominently shown. The second digit indicates related elements or features, and a final letter (when used) indicates a sub-portion of an element or feature.

30 REFERENCE NUMERALS IN DRAWINGS

The table below lists the reference numerals employed in the figures, and identifies the element designated by each numeral.

	Delivery Unit	10
	Generally Flat Member	10F
	Hermetic Sealing Layer	10H
	Medication	10M
5	Shaped Member	10S
	Tough Layer	10T
	Force Arrow F	
	Medication Chamber	12M
	Pumping Chamber	12P
10	Tunnel Conduit	14
	Perimeter Seal	16
	Perimeter Lip	16F
	Perimeter Lip	16S
	Delivery Port	18
15	Pull-away Closure	18C
	Rupture Flap	18F
	Rupture Site	18S
	Delivery System	20
	Divider Perforations	20D
20	Generally Flat Member	20F
	Medication	20M
	Shaped Member	20S
	Delivery Units	20U
	Medication End	21M
25	Pumping End	21P
	Medication Chamber	22M
	Pumping Chamber	22P
	Tunnel Conduit	24
	Medication Exit	24M
30	Pumping Entrance	24P
	Interior Seal	24S
	Perimeter Seal	26
	Delivery Port	28
	Pull-away Closure	28C
35	Rupture Flap	28F
	Rupture Site	28S
	Weak Rupture Seal	28W
	Spacing S	
	Delivery System	30
40	Common Chamber	30C
	Medication	30M
	Medication Volume	32M
	Pumping Volume	32P
	Delivery Port	38
45	Rupturing Site	38S
	Delivery Unit	40
	Transparent Shaped Member	40S
	Medication Chamber	42M
	Pumping Chamber	42P
50	Rupture Flap	48F
	Table Top	48T
	Push Arrow P	
	Rupture Arrow R	

GENERAL EMBODIMENT - (FIG. 1 ABC)

Sealed delivery unit 10 (shown in exploded format in FIG. 1A) contains a small product such as medication 10M. The delivery unit has a generally flat member 10F pressed into selective engagement with an opposed shaped member 10S. A suitable pumping volume, such as chamber 12P, is enclosed between the flat member and the shaped member. The pumping chamber generates a rupturing pressure in response to an external force applied by the user (indicated by arrow F shown in FIG. 1B). The user may be the end-user, (the person who consumes the medication), or a home caretaker or facilitator, or a professional staff person. A suitable product volume, such as medication chamber 12M, is enclosed adjacent to the pumping chamber for containing the medication to be delivered. The two chambers are in fluid communication through tunnel conduit 14, for rupturing the medication chamber in response to the rupturing pressure from the pumping chamber. The tunnel conduit is formed between the flat member and the opposed shaped member by the selective pressing engagement. Perimeter seal 16, formed during the selective pressing engagement, extends around the pumping chamber and the medication chamber and the tunnel conduit. The perimeter seal is secure enough to withstand the internal rupturing pressure generated during delivery. The perimeter seal prevents ambient air and dust from entering the sealed unit and adversely affecting the medication. The perimeter seal may be hermetic for preventing migration of moisture into the unit during long-term storage.

The gas inside the perimeter seal may be any suitable fluid, such as ambient air, dry air, or an inert gas such as nitrogen. Delivery port 18 with pull-away closure 18C (see FIG. 1C) delivers medication 10M out of medication chamber 12M. Rupture site 18S is proximate the

delivery port. Rupture flap **18F** produced by the rupturing at the rupture site, is connected to the pull-away closure. The flap projects outward permitting the user to grasp the pull-away the closure and open the delivery port for delivery of the medication. The shaped member is preferable transparent, permitting the user to visually identify the medication before rupturing and delivery. Perimeter lip **16F** may extend along the perimeter of the flat member (as shown in exploded view **FIG. 1A**), and opposed perimeter lip **16S** may extend along the perimeter of the shaped member. The opposed perimeter lips form the perimeter seal around the pumping chamber and the medication chamber.

Shaped member **10S** may be of any suitable material such as PVC or PET for protecting the medications. Flat member **10F** may have multiple layers to provide strength and enclosure. Tough layer **10T**, pressed against the shaped layer, may be of any suitable resistant material such as polyethylene. Hermetic layer **10H**, pressed against the tough layer, may be any suitable sealing material such as a metal foil.

The delivery port may be in the flat member (as shown in **FIG. 1C**). Rupture site **18S** may be a suitable cusp or rift in the flat member, such as a score made by a laser beam or a mechanical scratching edge. Preferably, the penetration of the score into the material of the flat member is deep enough to weaken the flat member, but not so deep as to cause breaching of the sealed unit. The rift score must be sufficiently frail to blow-out under rupturing pressure, and sufficiently secure to maintain the sealed closure. Rupture flap **18F** may be a tab or a triangular piece of flat member material over the rupture site. Pull-away closure **18C** of the delivery port may be defined by a tear-away border in the flat member. The

5 tear-away border may have three side as shown in FIG. 1C,
with the fourth side remaining attached to the flat
member. In the embodiment of FIG. 2B, the tear-away
border is annular with four sides as shown in FIG. 2B,
and pull-away closure 28C is completely removable. The
tear-away border and pull-away closure may be various
shaped and sizes, so long as the medication can pass
through the delivery port. The tear-away border may be a
series of weakening perforations or dents part-way
10 through the flat member. Alternatively, the tear-away
border may be a score in the flat member, similar to the
rupture score.

MULTIPLE UNITS EMBODIMENT - (FIG.s 2AB)

15 Sealed delivery system 20 has a plurality of
delivery units 20U enclosed between shaped member 20S
(see front view FIG. 2A) and flat member 20F (see back
view FIG. 2B). Each unit has pumping chamber 22P and
medication chamber 22M with conduit 24 providing fluid
20 communication therebetween. Perimeter seal 26 extends
around the delivery units for sealing the pumping
chambers and the medication chambers. Each unit has a
delivery port 28 on the back with a pull-away closure 28C
with rupture flap 28F. In the embodiment of FIG. 2,
25 rupture site 28S is an "X" shaped score on the perimeter
seal and near the border of closure 28C. A weak rupture
seal 28W (indicated by single hatching lines) may be
employed proximate each rupture site. The rupture seal is
a weak bond between shaped member 20S and flat member
30 20F, which has been pretreated prior to the pressing
engagement to reduce the strength of the perimeter seal
at the rupture site. During the pumping cycle, the
pumping pressure builds-up within the product chamber.
The pressure slips through the rupture seal and blows
35 open at the rupture site, producing the rupture flaps.

In delivery system 20, each delivery unit 20U is elongated with a pumping end 21P for the pumping chamber and a medication end 21M for the medication chamber. The delivery units are arranged adjacently side-by-side with the pumping chamber of each delivery unit next to the medication chamber of the adjacent delivery unit in alternating sequence. The units are preferably separated by divider score or perforations 20D.

The pumping chambers may be dome-shaped (as shown in FIG. 1A) for easy compression by the user to generate the rupturing pressure. The domes yield and collapse, displacing air through the tunnel conduit. The medication chambers may be cube-like, with rigid sidewalls, which do not crush or buckle as easily as the domes. The side walls provide spaced barriers between alternate domed pumping chambers (indicated by Spacing S in FIG. 2A). The spacing is wide enough for the user's thumb or finger, or for a small pressing instrument. The barriers prevent the user from pressing or disturbing more than one dome in a single compression cycle. The domes may be sufficiently resilient to return to the original dome-shape after compression, and refill for providing another rush of air. The user may repump the dome to assist in dislodging medications hung-up on the rough tear-away edges of the delivery port.

Tunnel conduit 24 has a pumping entrance 24P opening from the pumping chamber, and a medication exit 24M opening into the medication chamber. The conduit provides fluid communication from the pumping chamber into the medication chamber. Interior seal 24S may be employed to seal off the tunnel conduit, sealing-off the medication chamber from the pumping chamber. The interior seal blocks the fluid communication during shipping and storage of the sealed unit, or other periods of non-use.

The interior seal bursts under the rupturing pressure, restoring fluid communication just prior to delivery. Some medications require an environmentally protected volume with a critical sealed perimeter. Small volumes present less internal air interface with the medication, and short perimeters have less possibility of failure and contamination. The interior seal isolates the medication from the air in the pumping chamber and from the effects of leakage in the perimeter seal around the pumping chamber. Pumping chamber 22P is out of fluid communication with medication chamber 22M until the rupturing pressure disables or removes the interior seal.

COMMON CHAMBER EMBODIMENT - (FIG. 3)

Delivery unit 30 has a common chamber 30C with pumping volume 32P at one end and medication volume 32M at the other end. Applying pressure to the pumping volume causes the rift over rupture site 38S in the medication end to blow-out. The common chamber embodiment does not have a tunnel conduit. The pump and medication are in fluid communication due to the common chamber. The rift may be an "L" shaped score (shown in bold in FIG. 3) at a corner location of delivery port 38.

COPLANAR EMBODIMENT - (FIG. 4)

The flat member and the opposed perimeter lips may be coplanar defining a stable working plane for opening the delivery unit. Coplanar delivery unit 40 may be placed near the edge of flat counter or table top 48T (see FIG. 4), with pumping chamber 42P firmly settled against the table top and medication chamber 42M overhanging the edge. At least the rift portion of the medication chamber extends beyond the table edge. The plane of the table top offers a firm, level surface for receiving and supporting the planar side of the delivery unit. The user presses down on pumping chamber 42P

against the table top (indicated by arrow P) causing rupture flap 48F to blow open downward (indicated by arrow R).

5 Applying pressure P at one end of the unit to get a rupture event R at the other end is an "indirection" not evident to a child. A wayward child will see the brightly colored medication through transparent, rigid shaped member 40S, and instantly focuses on the "candy-like" object.

10

INDUSTRIAL APPLICABILITY

It will be apparent to those skilled in the art that the objects of this invention have been achieved as described hereinbefore by providing a product delivery unit in which the user does not apply force or other pushing coercion directly on the medication. The medication chamber ruptures and the product drops out through a delivery port in response to compressed air.

15

20 The medications is not require touched until after delivery. The opening procedure that is readily understood by adults, but opaque and indirect to for young children. The compressed air assists the user in removing medications stuck in the delivery port. The medications may be delivered without disturbing adjacent non-delivered medications.

25

Various changes may be made in the structure and embodiments shown herein without departing from the concept of the invention. Further, features of

30

embodiments shown in various figures may be employed in combination with embodiments shown in other figures. Therefore, the scope of the invention is to be determined by the terminology of the following claims and the legal equivalents thereof.

35

The embodiments of the invention in which an exclusive property or privilege is claimed are defined as follows:

1) A sealed unit for delivering a product in response to a rupturing pressure, comprising:

a generally flat member;

a shaped member opposed to the flat member, and pressed into selective engagement with the flat member, wherein a pumping volume is enclosed between the flat member and the opposed shaped member for generating the rupturing pressure in response to an externally applied force;

a product volume enclosed between the flat member and the opposed shaped member for containing the product to be delivered;

a fluid communication between the pumping volume and the product volume permits the rupturing the product volume in response to the rupturing pressure from the pumping volume;

a product contained in the product volume;

a perimeter seal formed during the selective pressing engagement, and extending around the pumping volume and the product volume, which perimeter seal can withstand the rupturing pressure;

a delivery port with a pull-away closure for delivering the product out of the product volume, wherein a rupture site proximate the delivery port ruptures outward under the rupturing pressure; and

a rupture flap produced by the rupturing at the rupture site, and connected to the pull-away closure, permitting pulling away of the pull-away closure to open the delivery port for delivery of the product contained within the product volume.

- 2) The delivery unit of claim 1, wherein the sealed pumping volume is a pumping chamber, and the sealed product volume is a product chamber.
- 3) The delivery unit of claim 2, further comprising a tunnel conduit within the perimeter seal, formed between the flat member and the opposed shaped member by the selective pressing engagement, having a pumping entrance opening from the pumping chamber and a product exit opening into the product chamber, and providing the fluid communication from the pumping chamber into the product chamber.
- 4) The delivery unit of claim 3, further comprising an interior seal for sealing-off the tunnel conduit between the product chamber and the pumping chamber, which interior seal fails under the rupturing pressure.
- 5) The delivery unit of any one of claims 1 to 4, further comprising a perimeter lip around the flat member; an opposed perimeter lip around the shaped member; which perimeter lips form the perimeter seal around the pumping volume and the product volume during the selective pressing engagement.
- 6) The delivery unit of claim 5, wherein the perimeter seal is hermetic.
- 7) The delivery unit of claim 5, wherein the flat member and the perimeter lips are coplanar.
- 8) The delivery unit of any one of claims 1 to 7, wherein the flat member further comprises:

a tough layer pressed against the shaped layer, and a hermetic foil layer pressed against the tough layer.

9) The delivery unit of any one of claims 1 to 8, wherein the delivery port out of the sealed product volume is through the flat member, and the rupture site is a rift in the flat member.

10) The delivery unit of claim 9, wherein the rupture site rift is a score in the flat member.

11) The delivery unit of claim 9, further comprising:
a rupture seal forming a weak section of the perimeter seal at the rupture site, wherein the rupture seal is configured to cause rupturing of at least one rupture flap.

12) The delivery unit of any one of claims 9 to 11, wherein the rupture flap is a triangular piece of the flat member covering at rupture site.

13) The delivery unit of any one of claims 9 to 12, wherein the pull-away closure of the delivery port is defined by a tear-away border within the perimeter seal around the product volume.

14) The delivery unit of claim 13, wherein the tear-away border is a series of perforations in the flat member.

15) The delivery unit of claim 13, wherein the tear-away border is a score in the flat member.

16) A sealed system for delivering medications in response to a rupturing pressure, comprising:

a flat member;

a shaped member opposed to the flat member, and pressed into selective engagement with the flat member;

a plurality of delivery units enclosed between the flat member and the opposed shaped member;

a pumping chamber within each delivery unit for generating the rupturing pressure;

a medication chamber within each delivery unit for containing the medication to be delivered;

a fluid communication between the pumping chamber and the medication chamber, for communicating the rupturing pressure from that pumping chamber to the medication chamber;

a medication contained in each medication chamber;

a perimeter seal formed during the selective pressing engagement to withstand the rupturing pressure, and extending around the delivery units for sealing the pumping chambers and the medication chambers;

a delivery port with a pull-away closure out of each medication chamber for delivering the medications in the sealed medication chambers;

a rupture site proximate each delivery port which ruptures outward under the rupturing pressure; and

a rupture flap produced by the rupturing of the rupture site, and connected to the pull-away closure, permitting pulling away of the pull-away closure to open the delivery port for delivery of the medication contained in the medication chambers.

17) The sealed delivery system of claim 16, wherein each delivery unit is elongated with a pumping end for the pumping chamber and a medication end for the medication chamber; and the delivery units are arranged adjacently

side-by-side with the pumping chamber of each delivery unit next to the medication chamber of the adjacent delivery unit in alternating sequence.

18) The sealed delivery system of claim 17, wherein:
the pumping chambers are dome-shaped for easy compression under the rupturing pressure; and
the medication chambers have rigid sidewalls for providing spaced barriers between alternate pumping chambers.

19) The sealed delivery system of claim 18, wherein the barrier spacing is wide enough to permit applying an external force to the pumping chamber for generating the rupturing pressure.

20) The sealed delivery system of claim 18 or 19, wherein the dome-shaped pumping chambers may be sufficiently resilient to regain the dome-shape after compression.

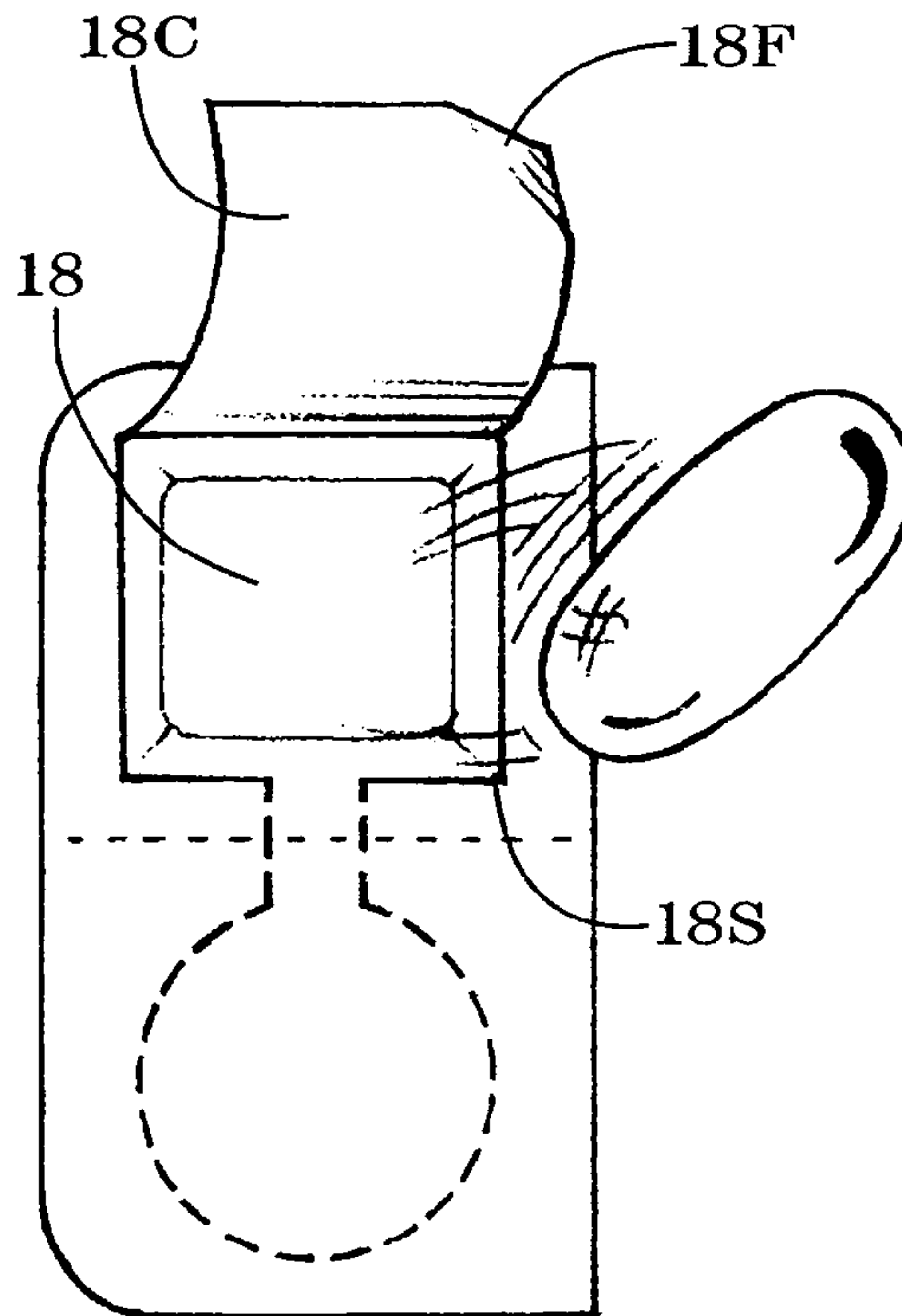
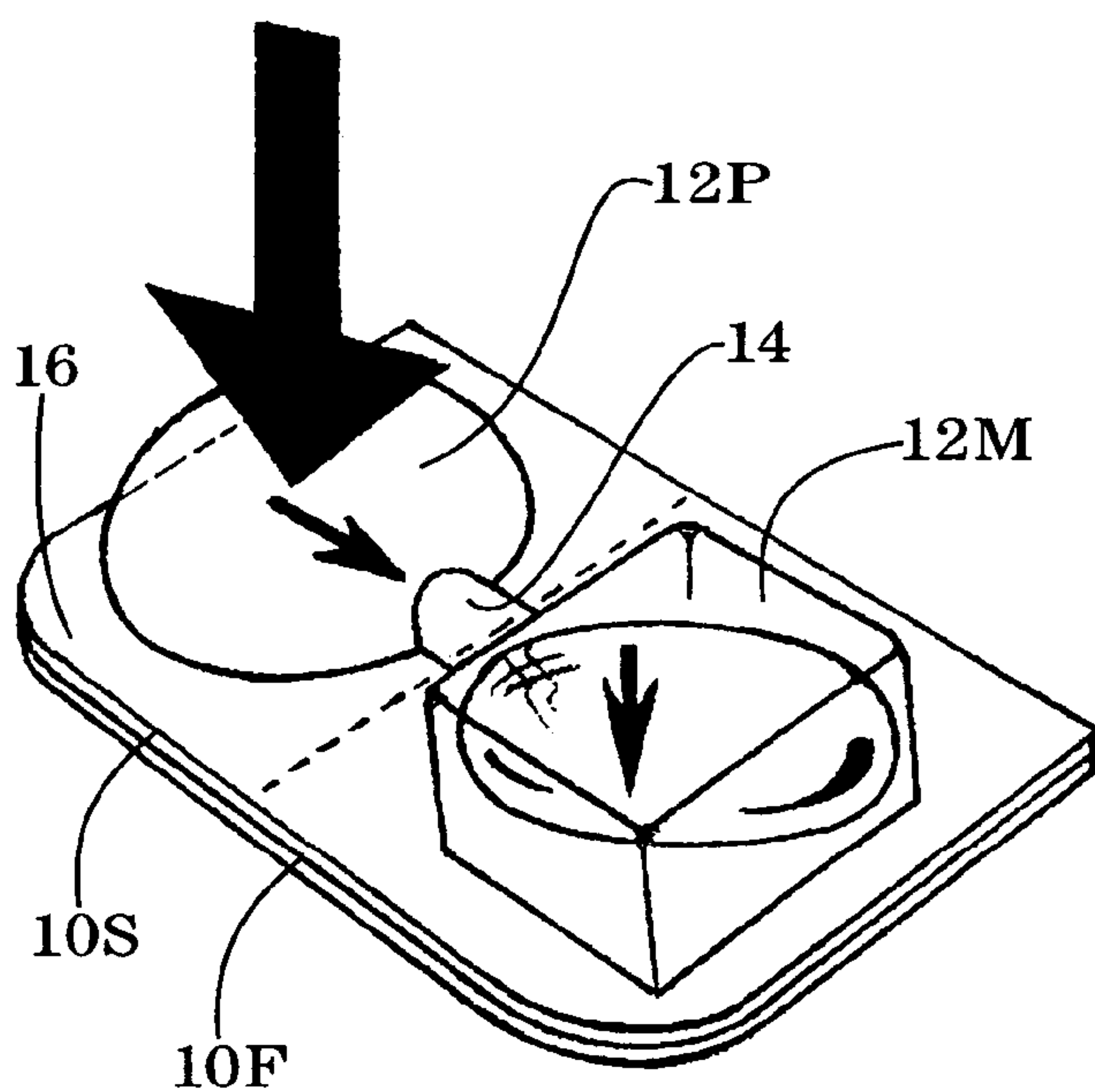
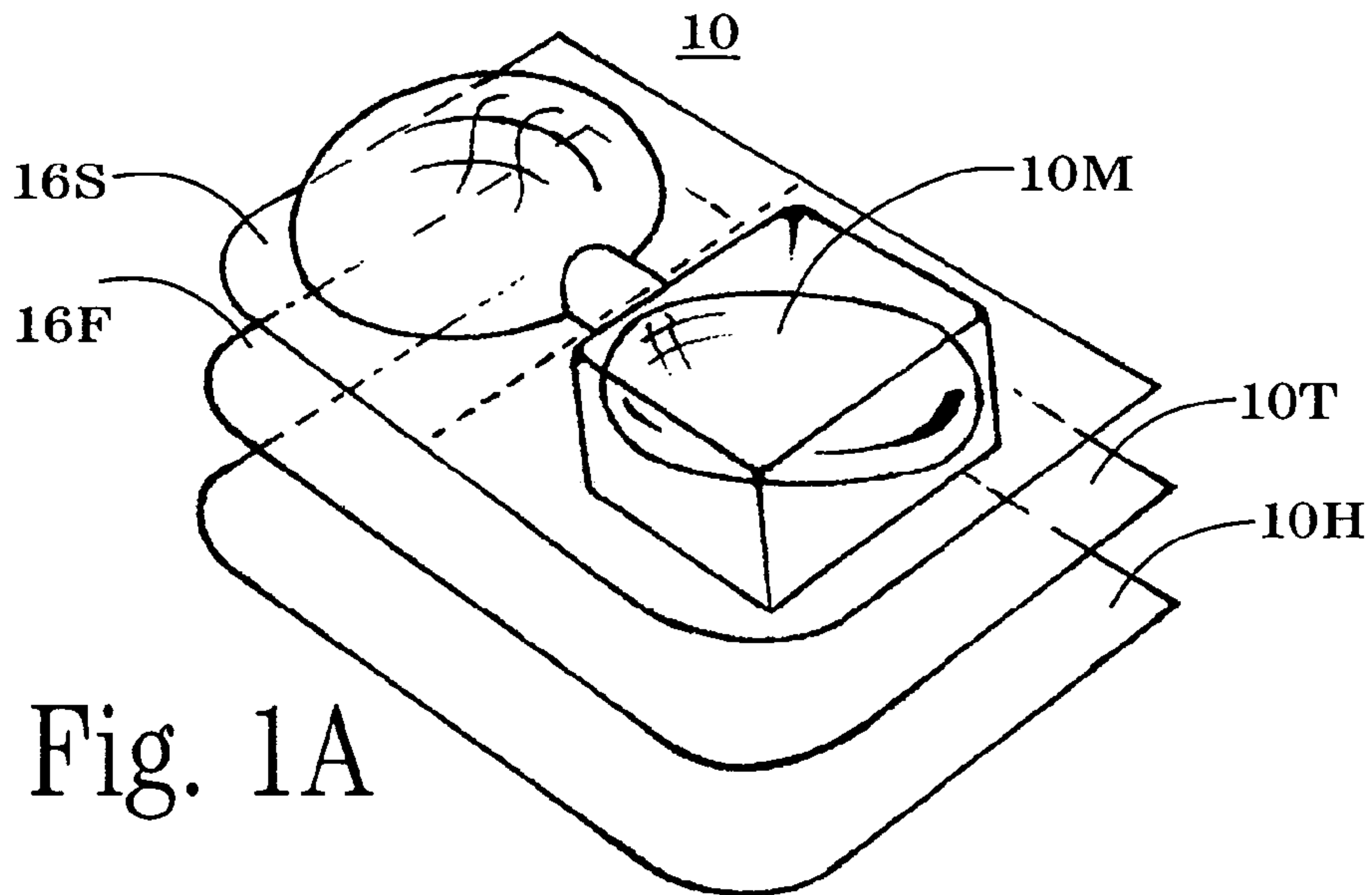

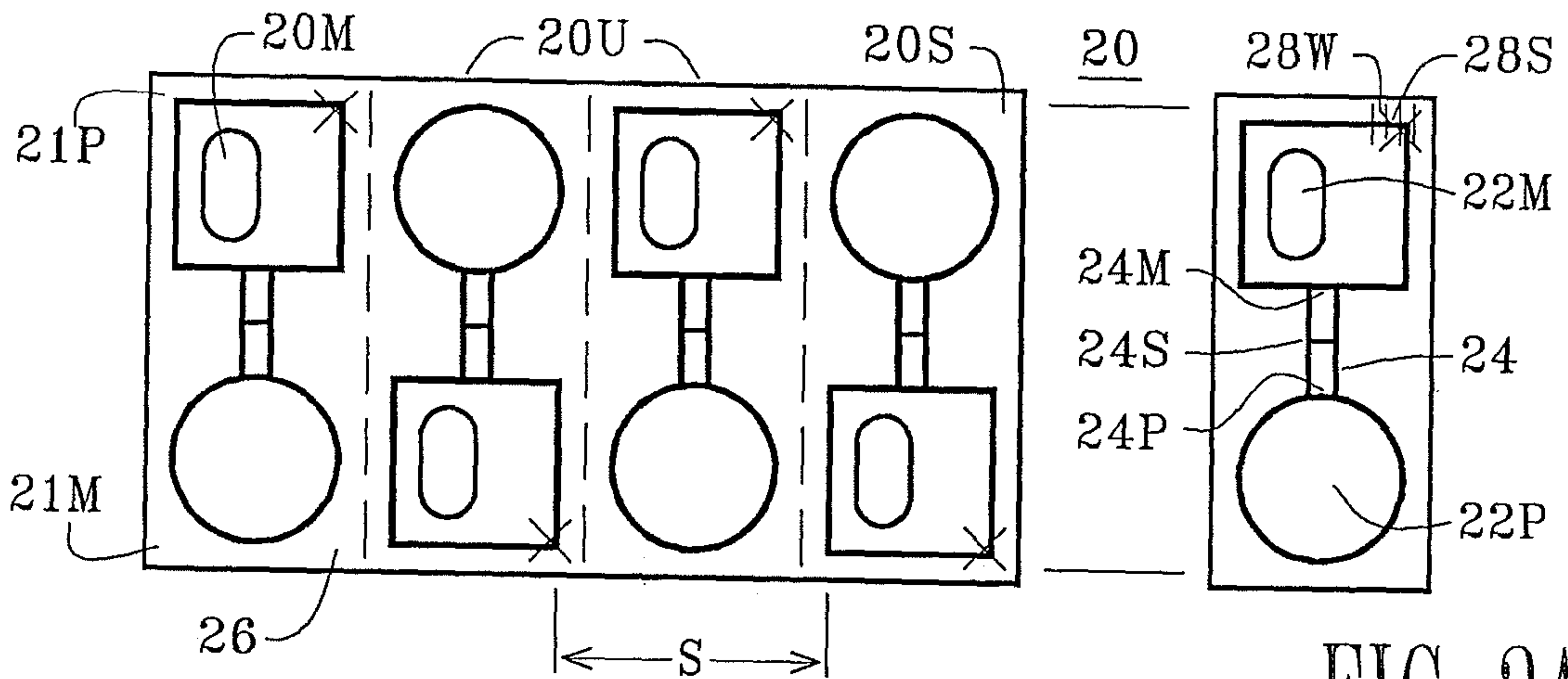

FIG 2A

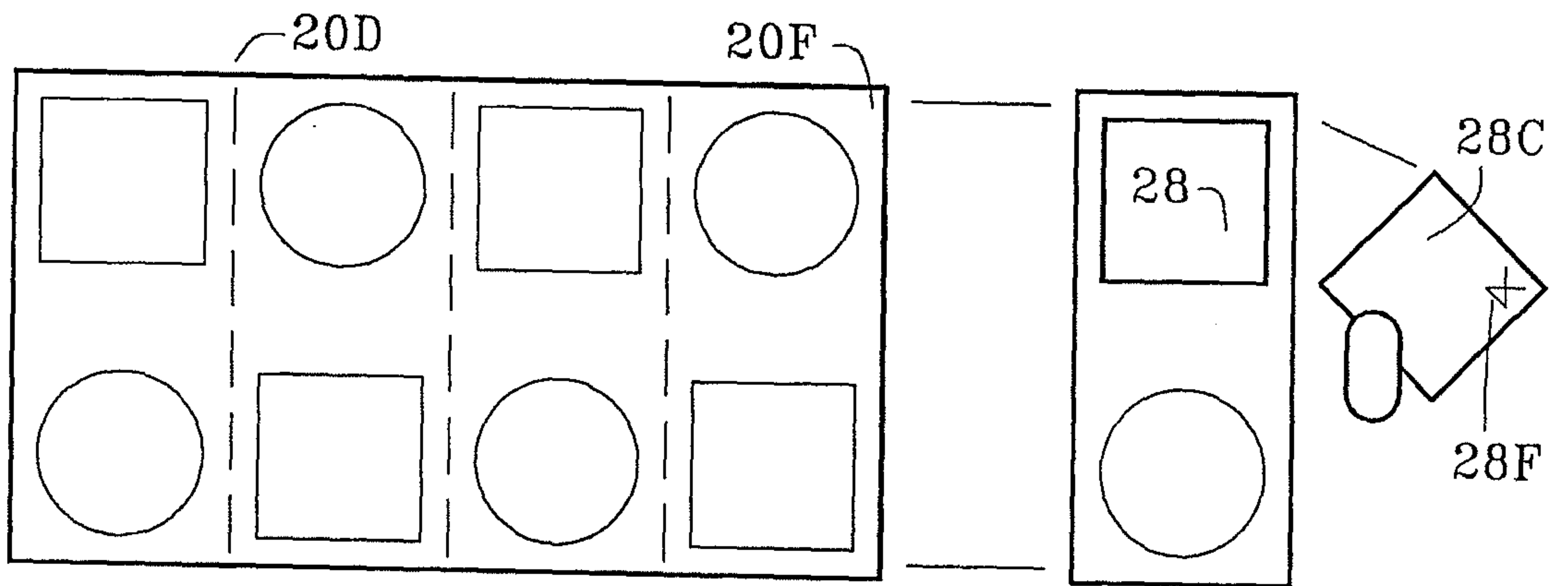

FIG 2B

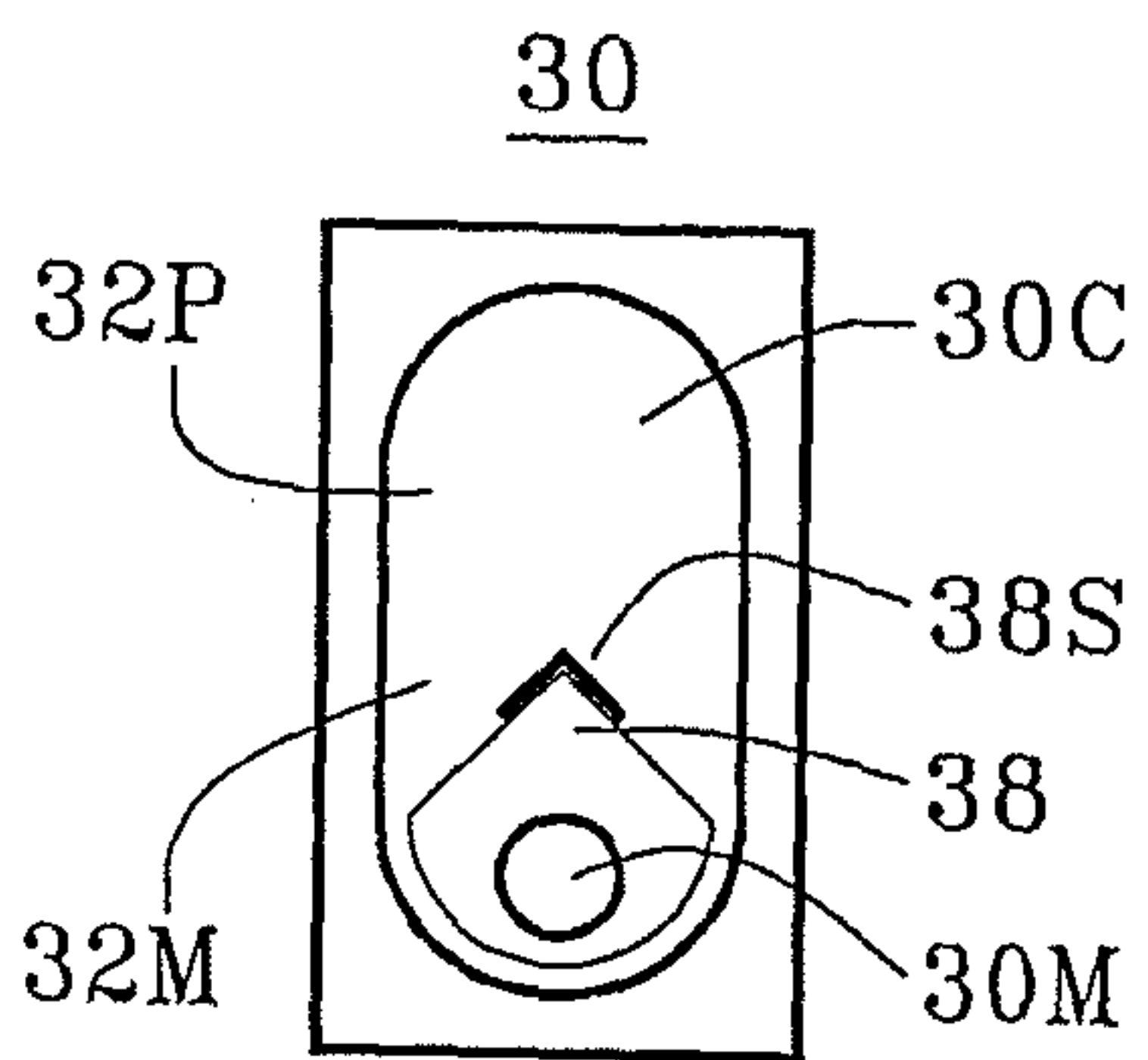

FIG 3

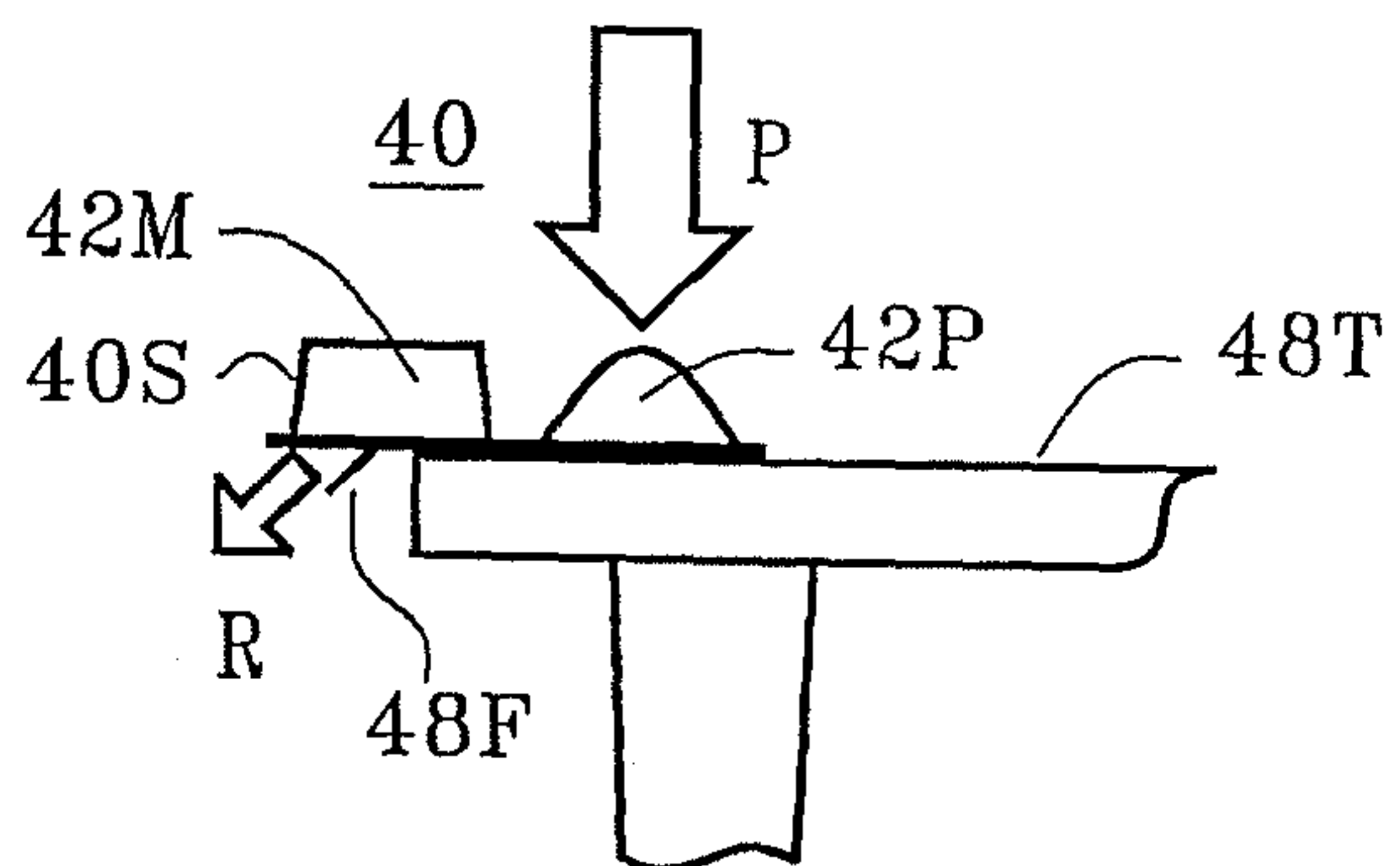

FIG 4

