



(11) **EP 1 945 007 A1**

(12) **EUROPEAN PATENT APPLICATION**

(43) Date of publication: **16.07.2008 Bulletin 2008/29** (51) Int Cl.: **H05B 37/02^(2006.01)**

(21) Application number: **07100432.9**

(22) Date of filing: **11.01.2007**

(84) Designated Contracting States:
AT BE BG CH CY CZ DE DK EE ES FI FR GB GR HU IE IS IT LI LT LU LV MC NL PL PT RO SE SI SK TR
 Designated Extension States:
AL BA HR MK RS

(72) Inventors:
 • **Frankinet, Marc**
4460 Horion-Hozemont (BE)
 • **Lang, Vincent**
4400 Flemalle (BE)

(71) Applicant: **Schreder**
1190 Bruxelles (BE)

(74) Representative: **Leherte, Georges M.L.M. et al**
Gevers & Vander Haeghen
Holidaystraat 5
1831 Diegem (BE)

(54) **Performance optimisation method of LED lighting devices**

(57) The invention relates to methods for optimising the performance of, for manufacturing and/or for controlling (street) lighting devices involving multiple LED-light sources within a common frame, in which specific LED-light sources are selected from a plurality of types of LED-light sources, specific secondary optics are selected from a plurality of types of secondary optics, for each selected LED light source, and specific orientations are selected for each of those LED-light sources and/or secondary optics, variables representing the light distribution in function of direction coordinates are associated to each LED light source and its secondary optics, and simulations of cumulative variables for multiple combinations of selected LED-light sources, selected secondary optics and selected orientations, are compared, using software assisted calculations, with selected global light distributions, so as to designate combinations of selected LED-light sources, selected secondary optics and selected orientations showing an optimal fit with said selected global light distributions, as well as to street lighting apparatus implementing these methods.

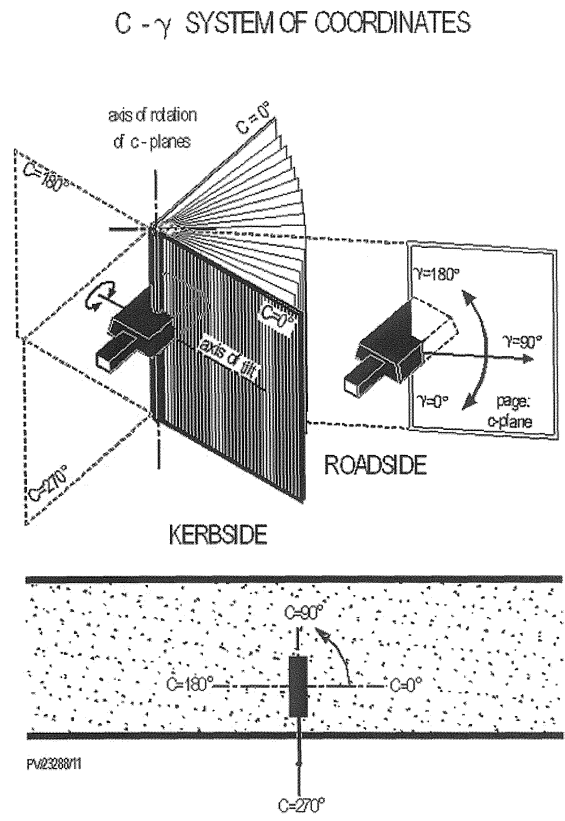

Fig. 1

EP 1 945 007 A1

Description

[0001] The invention relates to the area of lighting.

More particularly the invention relates to the emerging application of Light Emitting Diodes (LED's) for lighting purposes in general, and more specifically for street lighting purposes.

LED's are considered by many to represent the future for lighting.

These new light sources involve new constraints and new problems in respect of development and production of lighting devices.

The conceivers of the present invention have investigated these constraints and problems with an innovative perspective so as to develop a new concept for designing LED-based lighting devices and for controlling such lighting devices.

[0002] A first innovative approach in this new concept involves the principle of "**filling a photometric volume**".

By applying software assisted analysis to various combinations of LED-light sources of different types with individual (secondary) optical means (such as lenses, etc.) of different types (using the photometric properties of the light sources and of the optical means as "variables"), it becomes possible to optimise the light distribution according to a desired pattern (or theoretical "lighting matrix") for a given application.

The "dimming" capability of LED-light sources provides a useful further variable in this context.

[0003] Another innovative approach in the new concept according to the invention involves the principle of "**optimising results at lighted surface level**".

In this approach the starting point is not the volume anymore but rather the result to achieve.

[0004] Software assisted calculations make possible to calculate the theoretical result that can be achieved by combining LED-light sources of different types with optical means of different types (again, using the photometric properties of the light sources and the optical means as "variables"), so that the performance of lighting devices can be predicted.

[0005] For implementing the calculations and analysis methods referred to here above it may be particularly suitable, in accordance with preferred features of the invention, to "describe" or "represent" the light distribution of the light sources and/or the lighting devices in accordance with one or more of the following concepts for providing representative (characterising) tables / diagrams (or "documents") for the most relevant variables / parameters of such light sources and/or the lighting devices :

C- γ system of coordinates,
Intensity tables,
Polar diagrams of luminous intensity,
Cartesian diagrams of luminous intensity,
Utilisation factor curves,
Isolux diagrams,

for which the theoretical basis can be summarised as follow :

C-y system of coordinates

[0006] This concept is illustrated by figure 1 attached to the present disclosure.

Intensity tables

[0007] The basis from which all graphical documents are derived is the intensity table of lighting devices ("luminaries"). The intensity table itself is presented in accordance with the standard system of coordinates, named C-gamma.

[0008] The "Commission Internationale de l'Eclairage" (CIE) has standardized the presentation format of the intensity tables for road lighting devices. This format presents intensity values in 52 vertical C-planes and for 25 gamma angles in each C-plane (from 0° to 90°).

Some of the goniophotometers used by the inventors even take much more measurements, to be able to measure light distributions of various kinds of lighting devices and not only road lighting devices. Measurements are taken each 10° in the C-planes and each 1° in gamma angles, from 0° (downward vertical line) to 99° (9° above the horizontal) in one type of goniophotometer; or from 0° up to 180° when the upper flux is also measured, with a newer type of mirror goniophotometer.

The result, from the first type photometer, is a table with 36 columns (one per C - plane) and 100 rows (one per α angle) and containing 3600 intensity values. This complete measurement guarantees a high level of accuracy. The photometric tests are generally made with the luminaire mounted horizontally. A horizontal position is defined as follows :

- For road lighting luminaires, we consider that the inclination angle is 0° when it is fixed on a bracket arm of a pole,

which is itself horizontal. If the luminaire has no side entry, but only a vertical fixing device, we consider that it is at 0° inclination when fixed normally on its vertical support.

- For any other type of luminaire (floodlight, tunnel lighting fitting or industrial light fitting), 0° inclination means that the protector (or the plane of exit of luminous flux) is in an horizontal plane.

In the case of a luminaire having a circular light distribution (typical industrial lighting luminaire), the resulting intensity table contains only one C-plane, all the others being identical.

However, in the laboratory, the photometric measurement of such a light distribution is performed in 8 C-planes (each 45° apart), and the intensity value for each gamma angle is the average of the values in the 8 C-planes.

Polar diagram of luminous intensity

[0009] The distribution of light intensity in each C-plane can be presented graphically under a system of polar coordinates (cf. Figure 2 showing the polar diagram of a specific LED-light source).

The benefit of this presentation is that we can appreciate very quickly (with a minimum of experience) if the light distribution is suitable or not to answer an actual lighting problem.

For a road lighting luminaire, the polar curves of intensity are generally presented in the 6 characteristic half C-planes :

- C-planes 0° and 180° (parallel to road axis)
- C-plane 90° (across the road in front of the luminaire)
- C-plane 270° (across the road behind the luminaire)
- the two principal vertical planes (C-planes containing the maximum intensity).

For an industrial lighting luminaire having a circular distribution, the polar curve in one C-plane gives all the information on the light distribution.

For other types of luminaires (floodlights, tunnel luminaires, industrial non-circular luminaires, etc), the polar curves of intensity are generally given for the two longitudinal half-C-planes (0° and 180°) and the two transverse half-C-planes (90° and 270°) to the luminaire.

Cartesian diagram of luminous intensity

[0010] In the case of a very narrow light distribution, like a narrow beam floodlight, the reading of the intensity values at the different gamma angles can be difficult, because of the sharpness of the curve in polar coordinates.

The Cartesian system of coordinates gives more facilities to read the intensity values, especially in the high gamma angles (cf. Figure 3).

Utilisation factor curves

[0011] "Utilisation factor curves" provide a photometric "document" making it possible to approach quickly an appropriate solution in road lighting.

The horizontal scale of the diagram (see figure 4) is graduated in terms of the mounting height of the luminaire in order to make the diagram valid for all mounting heights. These horizontal distances are measured across the road, on the intersection of the C-planes 90° and 270° with the ground.

The vertical scale is graduated in percent of the rated flux of the lamp fitted inside the luminaire.

The luminaire is located on the horizontal scale at OH.

The letter K is used to designate the utilization factor.

The diagram comprises two curves :

- the curve K1 shows the luminous flux distribution in front of the luminaire (street side)
- the curve K2 shows the luminous flux distribution behind the luminaire (house side).

For a given road section taken on the diagram, you can read the percentage of flux arriving on the road itself.

[0012] Similar conclusions can be drawn from the comparison of utilization factor curves as those drawn from the comparison of the polar intensity curves in the C-planes 90° and 270° going across the road.

The balance between the amount of luminous flux going in front of the luminaire (street side) and behind the luminaire (house side) mainly depends on the geometrical size of the lamp, and associated reflector systems.

For a luminaire using an LPS lamp, there is approximately the same amount of flux in front and behind the luminaire. About 20% to 25% of the flux emitted by the lamp reaches a road having the same width as the mounting height of the

luminaire.

[0013] A luminaire using a HPMV lamp gives approximately 30% to 35% of the flux of the lamp on a road width = 1 H. The proportion of flux in front is now better than with the LPS lamp.

5 The luminaires equipped with HPS clear tubular lamps are able to concentrate more than 40% of the flux of the lamp on the same width road, with minimum of back flux. The very small size of the lamp's arc tube makes it possible to adjust the light distribution to particular needs.

The total efficiency of the luminaires (roughly K1 + K2) also depends on the geometrical sizes of the lamps. The total efficiency increases when the lamp becomes smaller.

10 **Isolux diagram**

[0014] Each curve of the isolux diagram joins all the points which have the same illuminance values (in lux).

The luminaire is located at the centre of the diagram.

The isolux diagram (see figure 5) is draw at the following scale :

15

1 x mounting height = 20 mm on our common documents.

20 It is also produced for a luminous flux of 1000 lumens, like all the other photometric documents.

In order to find the actual illuminance value of a particular point on the ground, we have to apply a conversion factor to the value read off the diagram, in lux. This conversion factor depends on :

- actual flux of the lamp in klm (kilolumens)
- 25 - mounting height of the luminaire (H),

in the following manner:

30

$$actual\ value = curve\ value \times \frac{flux\ of\ lamp\ (klm)}{H^2}$$

35 Using the concepts referred to here above one can thus, for instance, represent the light distribution of a single LED by a polar diagram as illustrated in figure 2.

Each LED has its own specific light distribution.

[0015] In addition to the naked LED-light source one can use secondary optics, such as a lens, a reflector, etc, which modify the light distribution.

40 By combining different types of LED-light sources with different types of secondary optics, one arrives at numerous light distributions defining typical beams (including very intensive, semi narrow, asymmetrical beams).

Each such basic light distribution, representative of a specific LED-light source combined with a specific secondary optics, can be referred to as a "Light Distribution Unit" (LDU), as illustrated by figures 6a and 6b.

[0016] Several LDU's together provide a global light distribution which can be suitable in a lighting device, such as a (street) lighting device or "luminaire, comprising multiple LED-light sources.

The luminaire can be seen as composed of facets emitting light in some direction.

[0017] Based on the different LDU's one can thus build a desired light distribution, by adding up different LDU's.

A typical or desired light distribution according to a specific pattern (or theoretical "lighting matrix"), as illustrated in figure 7, can thus be "build" by adding up specific LDU's in the right direction (plane C and angle γ) as illustrated by figure 8.

50 The chosen types, directions and numbers of LDU's will define the global light distribution.

[0018] Applying the principles referred to above (calculation methods and representation concepts for the relevant variables) one can calculate which LDU's to use for creating a desired global light distribution (as a specific pattern or "lighting matrix").

[0019] In contrast to this approach street lightings involving LED-light sources according to the state of the art only provide

55

2 D light distribution, by using directed flat arrays of LED-light sources, or very limited 3 D light distribution ("cut off" light distribution), by using flat arrays of LED-light sources with (flat array) optical lens systems which can, to some extent, control the light in selected directions, but cannot send light to high γ angles.

These known approaches therefore are synonymous of short spacing between the luminaries.

[0020] It is the objective of the present invention to remedy the drawbacks encountered in the state of the art by providing innovative

5 methods for designing,
 methods for manufacturing, and
 methods for controlling lighting devices,

as well as by providing

10 new types of lighting apparatus resulting from, respectively capable to implement, such methods.

[0021] The invention there for provides a method for optimising the performance of a (street) lighting device involving multiple LED-light sources within a common frame, wherein specific LED-light sources are selected from a plurality of types of LED-light sources, specific secondary optics are selected from a plurality of types of secondary optics, for each selected LED light source, and specific orientations are selected for each of those LED-light sources and/or secondary optics, wherein variables representing the light distribution in function of direction coordinates are associated to each LED light source and its secondary optics, and wherein simulations of cumulative variables for multiple combinations of selected LED-light sources, selected secondary optics and selected orientations, are compared, using software assisted calculations, with selected global light distributions, so as to designate combinations of selected LED-light sources, selected secondary optics and selected orientations showing an optimal fit with said selected global light distributions.

[0022] According to preferred features of the performance optimisation method according to the invention, the variables associated to each LED light source and its secondary optics are defined in accordance with

25 a C- γ system of coordinates,
 Intensity tables,
 Polar diagrams of luminous intensity,
 Cartesian diagrams of luminous intensity,
 Utilisation factor curves, and/or
 30 Isolux diagrams.

[0023] In a first specific and preferred embodiment to implement this method for optimising the performance of lighting devices involving multiple LED-light sources, once all necessary calculations in accordance with the basic concept of the invention (in particular the "flee eye" calculation concept) have been made (i.e. calculating the number and types of LED's to be used, the types of secondary optics to be associated to each LED, and the orientations of each of those), the invention proposes the use of "flexible print boards".

In this embodiment of the invention all the LED-light sources, secondary optics and necessary electronic components are mounted on a (flat) flexible print board (as illustrated by figure 9) that can be placed on and adapted to any kind of mechanical support structure / three dimensional base structure, fixing the orientation of the LED-light sources (as illustrated by figure 10).

The mechanical support structure can, for instance, involve a bended metal sheet, a deep drawn metal structure, a die cast metal structure, or a machined aluminium structure.

[0024] For meeting the objectives of the invention stated further above, the invention thus also specifically provides a first new method for designing and/ or making / manufacturing (street) lighting devices comprising multiple LED-sources within a common frame, with at least part of said LED-light sources being provided to a semi-flexible printed circuit, which method comprises the steps of

providing one or more types of three dimensional base structures for lighting devices,
 providing one or more types of semi-flexible printed circuits adapted to receive the LED-light sources of the lighting device according to selected directions of the light sources, and

50 applying one semi flexible printed circuit on one three dimensional base structure of a type corresponding to said one semi flexible printed circuit,
 so as to provide a defined three dimensional configuration of the LED-light sources' positions and orientations.

[0025] In a preferred embodiment of this manufacturing method for lighting devices, the semi-flexible printed circuits may very suitably involve several modules for one or more LED-light sources, with the capability to have each light source within one module directed into a selected direction and/or provided with individual optical means, and with each module having the capability to be bended according to a selected direction.

[0026] In a second specific and preferred embodiment to implement this method for optimising the performance of a lighting devices involving multiple LED-light sources, once all necessary calculations in accordance with the basic

concept of the invention have been made, the invention proposes the use of a "LED-modules on mechanical structures" ("Modular concept").

This modular concept may suitably involve LED-modules, composed of

5

a heat sink structure, to dissipate, on its backside, the heat generated by the LED-light sources, a print board (rigid, or flexible for allowing multiple LED orientations on one module), LED-light sources, necessary electronic components,

10

optional protection and/or tightness features,

a mechanical structure, composed of

15

a three dimensional main structure ("wing"), providing an appropriate orientation for each module, a protector structure (global protector or individual protector for each module), optionally with a suitably designed "chimney" zone behind the "wing" zone, to evacuate the heat to the top of the device, into the ambient air,

with the purpose of

20

orienting each module in a specific direction in accordance with the required light distribution, dissipating the heat from the LED-light sources via the heat sink structures of the LED-modules.

Figures 11 a and 11 b illustrate this modular concept, by way of example.

25

[0027] For meeting the objectives of the invention stated further above, the invention thus also specifically provides a second new method for designing and/ or making / manufacturing (street) lighting devices comprising multiple LED-sources within a common frame, with at least part of said LED-light sources being provided on modules, which method comprises providing

30

LED-modules composed of a heat sink structure, a print board, LED-light sources, necessary electronic components, and optional protection and/or tightness features, and

a mechanical structure, composed of a three dimensional main structure providing appropriate orientation for each module, a protector structure for said modules, with optionally a "chimney" zone to evacuate heat.

35

[0028] For meeting the stated objectives of the invention, the invention also provides a first new type of (street) lighting apparatus comprising multiple LED-light sources within a common frame (/ on a common support structure) with at least part of said LED-light sources being provided to a semi-flexible printed circuit, which apparatus comprises several modules of one or more LED-light sources, each module being a separately bendable part of a common semi-flexible printed circuit, each light source within one module being directed into a selected direction, and/or being provided with individual optical means, and each module being directed into a selected direction, whereas the power feed to each module, optionally each light source, is separately regulated by software controlled means.

40

[0029] According to a preferred feature of the lighting apparatus according to the invention, the separately bendable parts of a common semi-flexible printed circuit defining said several modules are applied on a three dimensional base structure so as to provide a defined three dimensional configuration of the LED-light sources' positions and orientations.

45

[0030] For meeting the stated objectives of the invention, the invention also provides a second new type of (street) lighting apparatus comprising multiple LED-light sources within a common frame (/ on a common support structure) with at least part of said LED-light sources being provided on modules, which apparatus comprises LED-modules composed of a heat sink structure, a print board, LED-light sources, necessary electronic components, and optional protection and/or tightness features, and

50

a mechanical structure, composed of a three dimensional main structure providing appropriate orientation for each module, a protector structure for said modules, with optionally a "chimney" zone to evacuate heat.

55

[0031] To meet the objectives stated further above the invention furthermore specifically provides a process for controlling a lighting device, in particular a street lighting device, involving multiple LED-light sources within a common frame, using several modules of one or more LED-light sources, each light source within one module being directed into a selected direction and/or provided with individual optical means, and each module being directed into a selected direction, whereas the power feed to each module, optionally each light source, is separately controlled.

[0032] For meeting the objectives stated above, the invention also specifically provides a software assisted method for controlling the performance of (street) lighting devices involving multiple LED-light sources within a common frame, wherein each lighting device comprises several modules of one or more LED-light sources, each light source within one module being directed into a selected direction and/or provided with individual optical means, and each module being

directed into a selected direction, whereas the power feed to each module, optionally each light source, is separately regulated by software controlled means.

[0033] According to other preferred aspects of the invention, the manufacturing method, apparatus, control process and, respectively, software assisted method, according to the invention may involve one or more of the following further features :

- the light sources in one module are directed into selected cooperating directions,
- the power feed to each module, optionally each light source, is separately controlled in respect of amperage ("dim-mability") and / or frequency.

[0034] An important feature of the lighting concepts disclosed above resides in the fact that they consist of multi-source concepts and that the light sources can be easily dimmed (reducing of light intensity) or switched on and off, by using appropriate electronic drivers (as such well known in the art).

[0035] This provides for optimal adaptation of the light distribution to various parameters, based on the facets concept and by controlling the light intensity of some LED-light sources in some directions, with even the possibility to modify the colour of the emitted light by using different types of coloured LED-light sources or RGB LED sources.

Such modification of the light distribution and / or colour distribution can thus adapt the photometrical performance of a lighting device according to many parameters, such as

climate, for instance due to rain, snow, frost, fog, ...

time, for instance due to ageing of the road surface leading to changed reflection characteristics, clogging of the road surface, renovation of the road surface, modification of light level with time (day, evening, night, ...), seasons ("warm white" during winter, "cool white" during summer)

traffic, for instance due to density of traffic, presence of accident or parked vehicle, traffic speed, type of vehicles (cars, trucks, ...)

geometry, for instance due to the configuration of the road (width, curvature, ...), spacing between lighting poles, specificities and singularities (round about, crossing, zebra crossing, ...)

geography, for instance according to different countries, specifications, norms (light level, colour, ...) - adaptation to different local requirements

Claims

1. Method for optimising the performance of a (street) lighting device involving multiple LED-light sources within a common frame, **characterised in that** specific LED-light sources are selected from a plurality of types of LED-light sources, specific secondary optics are selected from a plurality of types of secondary optics, for each selected LED light source, and specific orientations are selected for each of those LED-light sources and/or secondary optics, **in that** variables representing the light distribution in function of direction coordinates are associated to each LED light source and its secondary optics, and **in that** simulations of cumulative variables for multiple combinations of selected LED-light sources, selected secondary optics and selected orientations, are compared, using software assisted calculations, with selected global light distributions, so as to designate combinations of selected LED-light sources, selected secondary optics and selected orientations showing an optimal fit with said selected global light distributions.

2. Performance optimisation method according to claim 1, **characterised in that** said variables are associated to each LED light source and its secondary optics according to

- a C-γ system of coordinates,
- Intensity tables,
- Polar diagrams of luminous intensity,
- Cartesian diagrams of luminous intensity,
- Utilisation factor curves, and/or
- Isolux diagrams.

3. Method for manufacturing lighting devices comprising multiple LED-sources within a common frame, with at least part of said LED-light sources being provided to a semi-flexible printed circuit, **characterised in that** said method comprises the steps of

- providing one or more types of three dimensional base structures for lighting devices,
- providing one or more types of semi-flexible printed circuits adapted to receive the LED-light sources of the lighting

device according to selected directions of the light sources, and
 applying one semi flexible printed circuit on one three dimensional base structure of a type corresponding to said
 one semi flexible printed circuit,
 so as to provide a defined three dimensional configuration of the LED-light sources' positions and orientations.

- 5
4. Manufacturing method according to claim 3, **characterised in that** said semi-flexible printed circuits comprise several modules of one or more LED-light sources, each module being a separately bendable part of said semi-flexible printed circuit, each light source within one module being directed into a selected direction, and/or being provided with individual optical means, and each module being directed into a selected direction, whereas the power feed to each module, optionally each light source, is separately regulated by software controlled means.
- 10
5. Manufacturing method according to any one of claims 3 and 4, **characterised in that** said semi-flexible printed circuits involve several modules for one or more LED-light sources, with the capability to have each light source within one module directed into a selected direction and/or provided with individual optical means, and with each module having the capability to be bended according to a selected direction.
- 15
6. Method for manufacturing lighting devices comprising multiple LED-sources within a common frame, with at least part of said LED-light sources being provided on modules, **characterised in that** said method comprises providing LED-modules composed of a heat sink structure, a print board, LED-light sources, necessary electronic components, and optional protection and/or tightness features, and a mechanical protection and/or tightness features, and a mechanical structure, composed of a three dimensional main structure providing appropriate orientation for each module, a protector structure for said modules, with optionally a "chimney" zone to evacuate heat.
- 20
7. Manufacturing method according to any one of claims 3 to 6, **characterised in that** said three dimensional configuration of the LED-light sources' positions and orientations results from a method according to any one of claims 1 and 2.
- 25
8. Street lighting apparatus comprising multiple LED-light sources within a common frame (/ on a common support structure) with at least part of said LED-light sources being provided to a semi-flexible printed circuit, **characterised in that** said apparatus comprises several modules of one or more LED-light sources, each module being a separately bendable part of a common semi-flexible printed circuit, each light source within one module being directed into a selected direction, and/or being provided with individual optical means, and each module being directed into a selected direction, whereas the power feed to each module, optionally each light source, is separately regulated by software controlled means
- 30
9. Street lighting apparatus according to claim 7, **characterised in that** said separately bendable parts of a common semi-flexible printed circuit defining said several modules are applied on a three dimensional base structure so as to provide a defined three dimensional configuration of the LED-light sources' positions and orientations.
- 35
10. Street lighting apparatus comprising multiple LED-light sources within a common frame (/ on a common support structure) with at least part of said LED-light sources being provided on modules, **characterised in that** said apparatus comprises LED-modules composed of a heat sink structure, a print board, LED-light sources, necessary electronic components, and optional protection and/or tightness features, and a mechanical structure, composed of a three dimensional main structure providing appropriate orientation for each module, a protector structure for said modules, with optionally a "chimney" zone to evacuate heat.
- 40
11. Process for controlling a (street) lighting device involving multiple LED-light sources within a common frame, **characterised in that** several modules of one or more LED-light sources are used, each light source within one module being directed into a selected direction and/or provided with individual optical means, and each module being directed into a selected direction, whereas the power feed to each module, optionally each light source, is separately controlled.
- 45
12. Software assisted method for controlling the performance of (street) lighting devices involving multiple LED-light sources within a common frame, **characterised in that** each lighting device comprises several modules of one or more LED-light sources, each light source within one module being directed into a selected direction and/or provided with individual optical means, and each module being directed into a selected direction, whereas the power feed to each module, optionally each light source, is separately regulated by software controlled means.
- 50
- 55

EP 1 945 007 A1

13. Performance optimisation method, manufacturing method, street light apparatus, controlling process or software assisted method according to any one of claims 4 - 12, **characterised in that** the light sources in one module are directed into selected cooperating directions.

5 14. Performance optimisation method, manufacturing method, street light apparatus, controlling process or software assisted method according to any one of claims 4 - 13, **characterised in that** the power feed to each module, optionally each light source, is separately controlled in respect of amperage ("dimability") and / or frequency.

10

15

20

25

30

35

40

45

50

55

C - γ SYSTEM OF COORDINATES

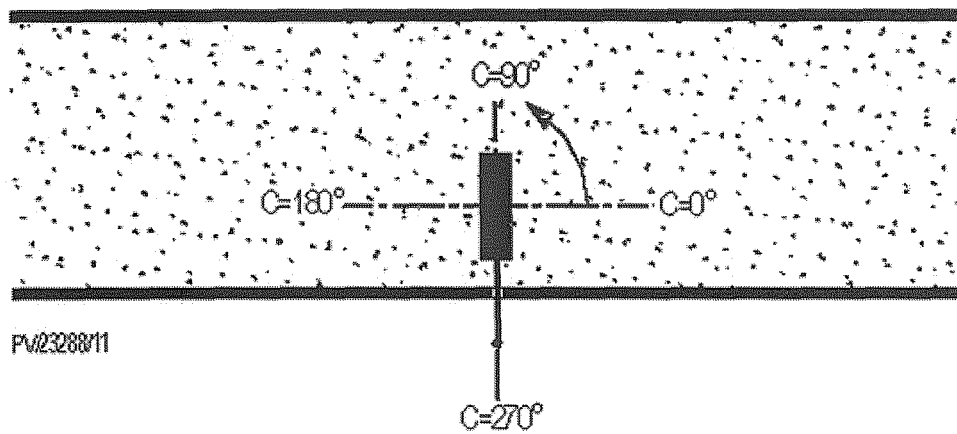
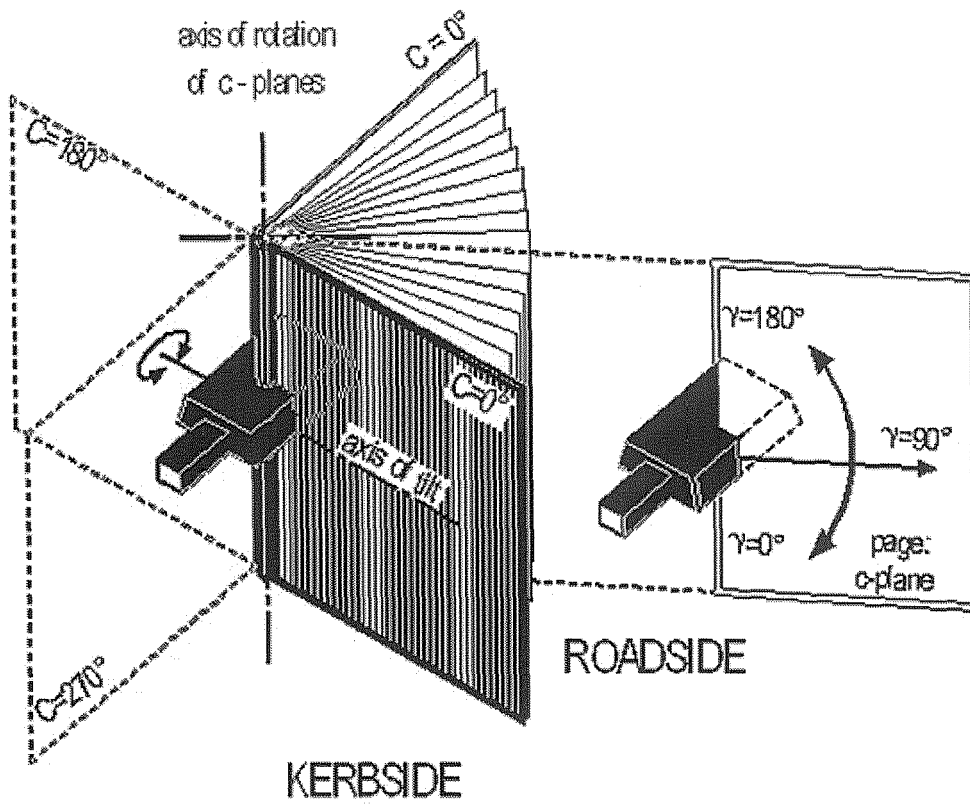

Fig. 1

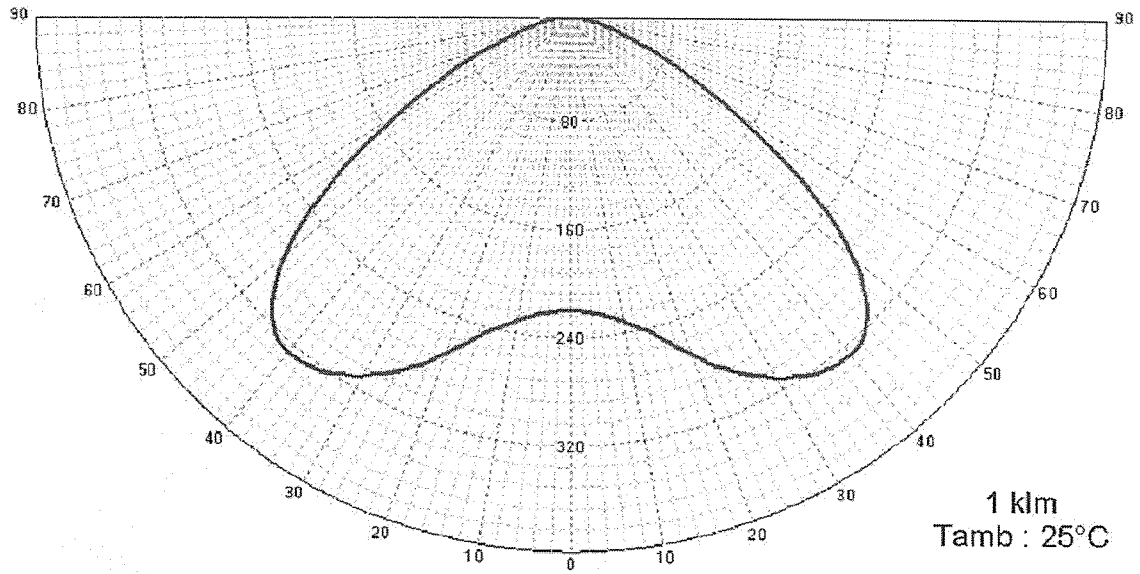

Fig. 2

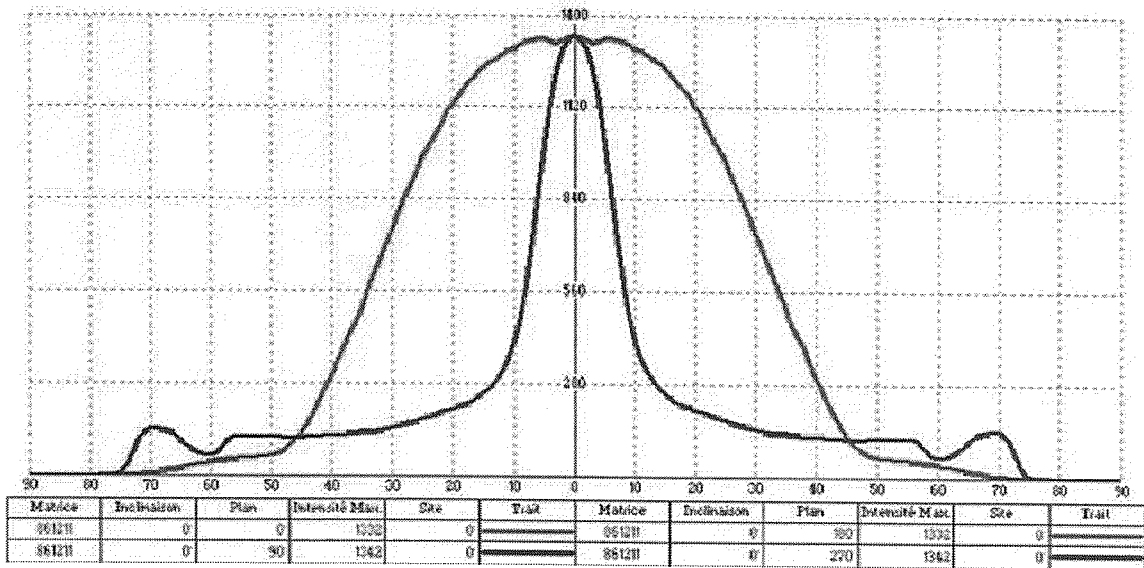

Fig. 3

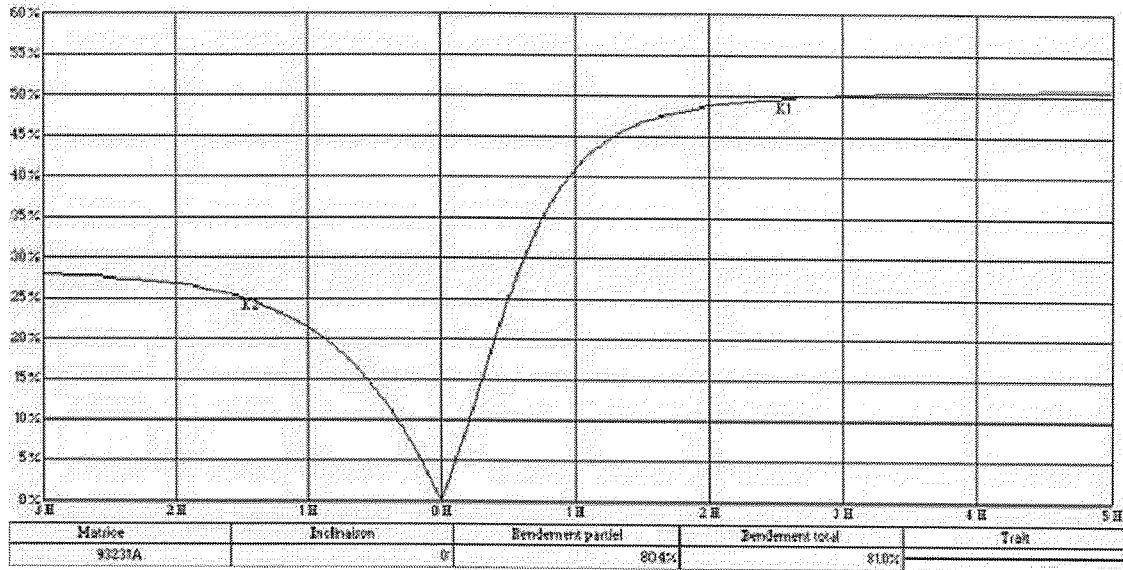

Fig. 4

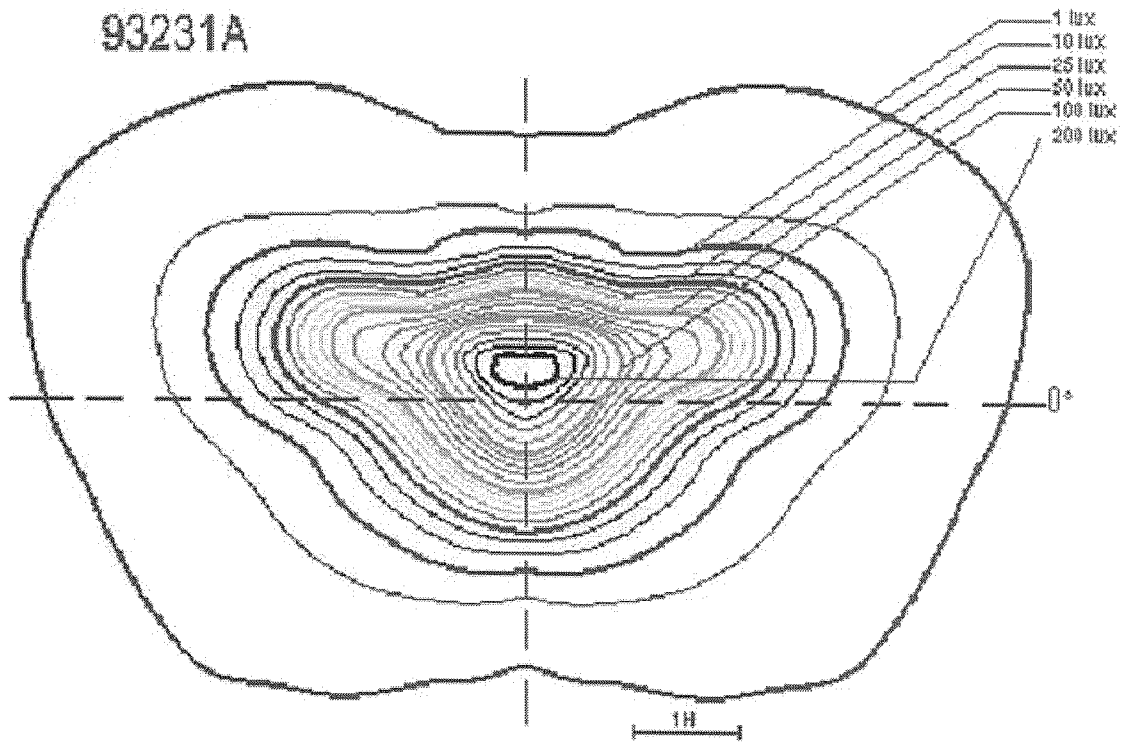

Fig. 5

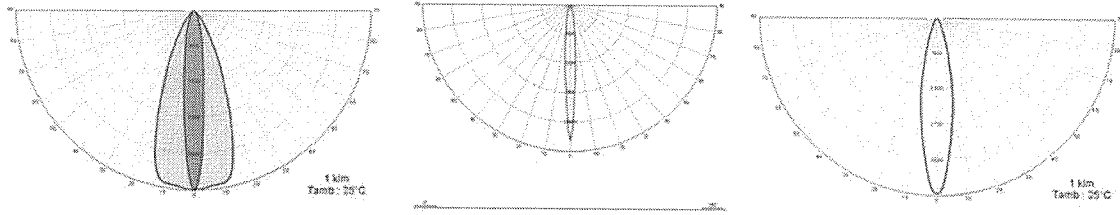

Fig. 6 a

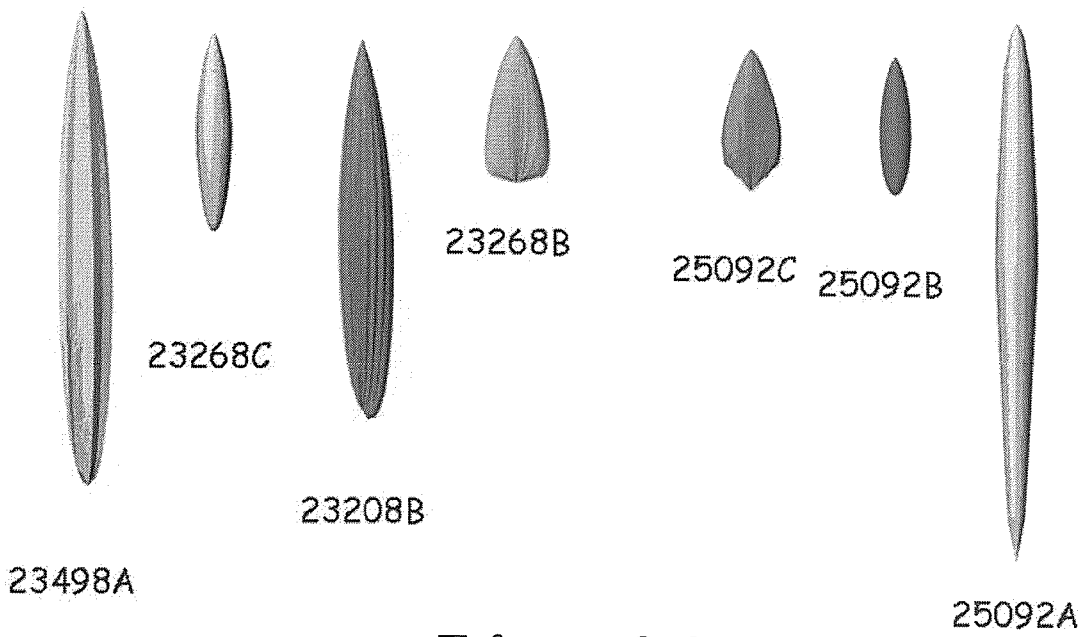

Fig. 6 b

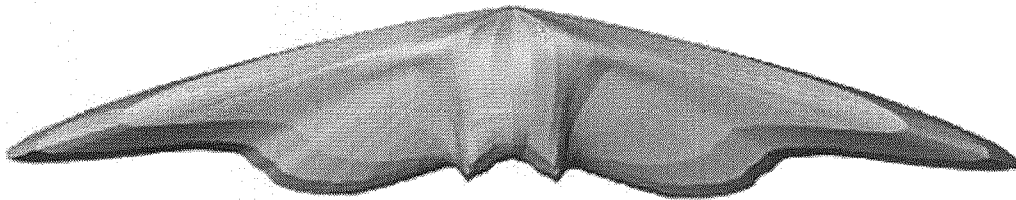

Fig. 7

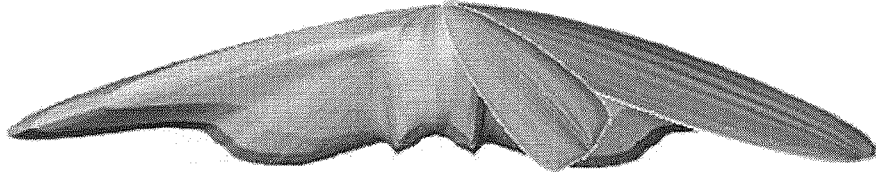

Fig. 8

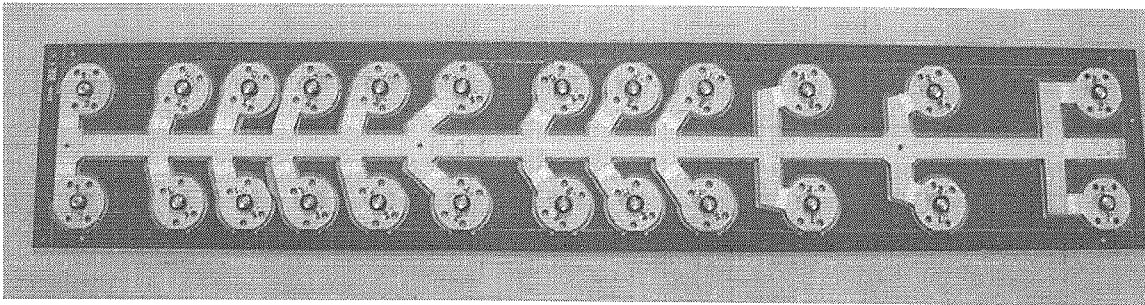

Fig. 9

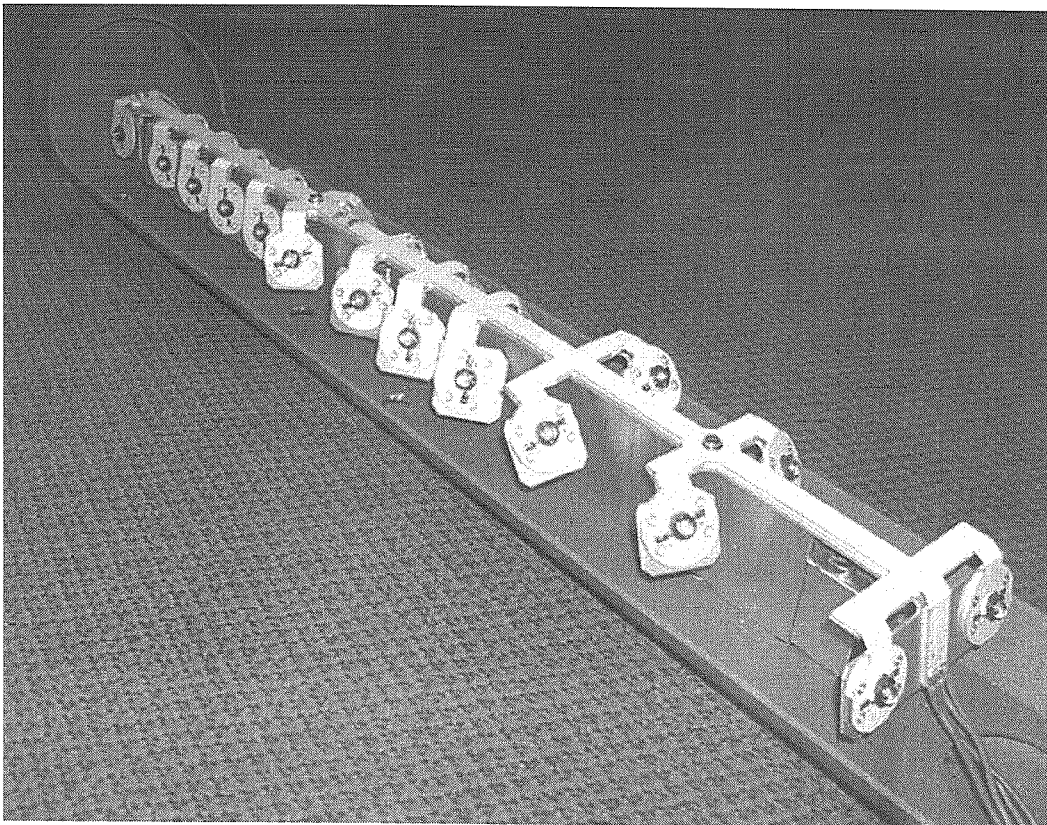

Fig. 10

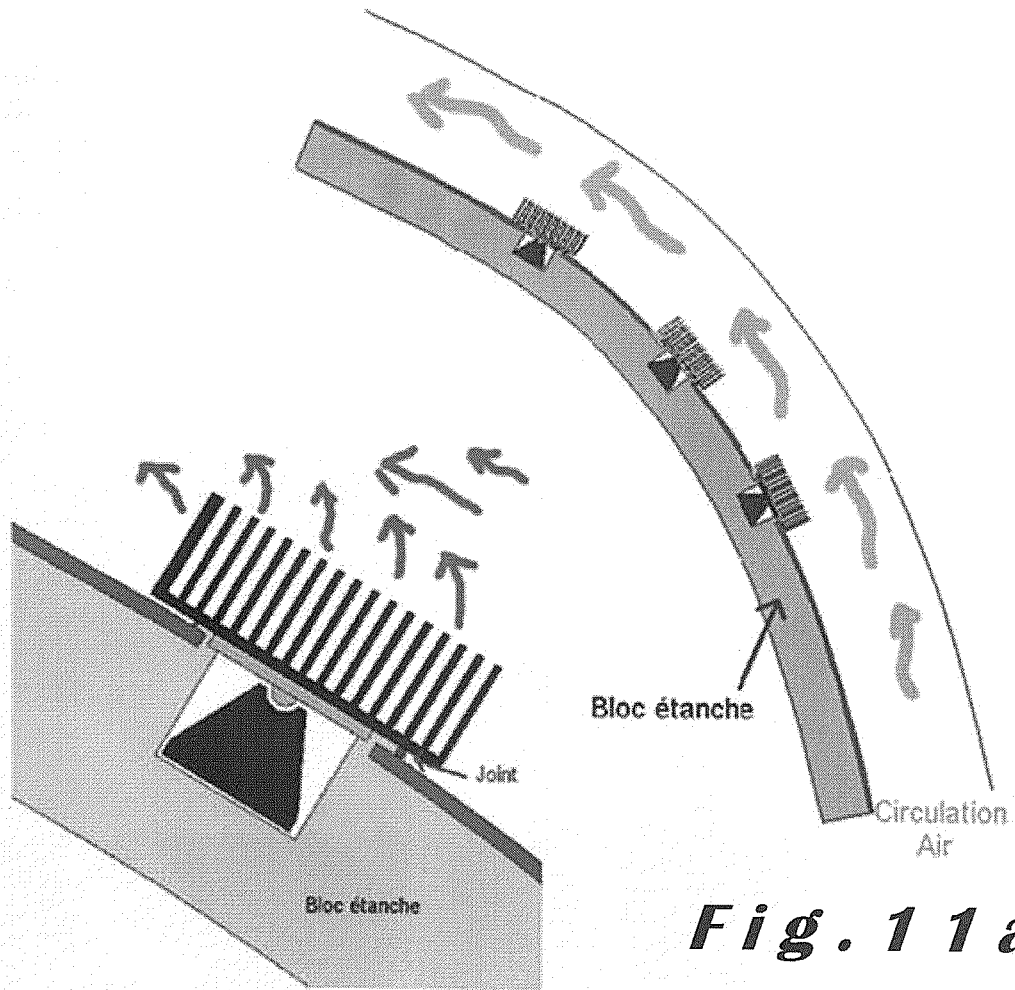

Fig. 11 a

Fig. 11 b



| DOCUMENTS CONSIDERED TO BE RELEVANT | | | |
|--|---|---|---|
| Category | Citation of document with indication, where appropriate, of relevant passages | Relevant to claim | CLASSIFICATION OF THE APPLICATION (IPC) |
| X | WO 99/50596 A (OTKRYTOE AKTSIONERNOE OBSHEST [RU]; BALASHOV VLADIMIR ILIICH [RU]; ZA) 7 October 1999 (1999-10-07) * page 7, line 7 - page 16, line 16 * ----- | 1,2 | INV. H05B37/02 |
| X | JP 11 329022 A (STANLEY ELECTRIC CO LTD) 30 November 1999 (1999-11-30) * the whole document * ----- | 1,2 | |
| X | US 2003/193807 A1 (RIZKIN ALEXANDER [US] ET AL) 16 October 2003 (2003-10-16) * paragraph [0020] - paragraph [0042] * ----- | 1,2 | |
| X | JP 2005 196983 A (MATSUSHITA ELECTRIC WORKS LTD) 21 July 2005 (2005-07-21) * the whole document * ----- | 1,2 | |
| E | US 2007/019432 A1 (SHIMADA TAKESHI [JP]) 25 January 2007 (2007-01-25) * the whole document * ----- | 1,2 | |
| X | US 2003/090910 A1 (CHEN HSING [TW]) 15 May 2003 (2003-05-15) * paragraph [0057] - paragraph [0072] * ----- | 3-5,13, 14 | TECHNICAL FIELDS SEARCHED (IPC) H05B |
| X | US 2005/254264 A1 (SIDWELL STEVEN C [US] ET AL) 17 November 2005 (2005-11-17) * paragraph [0014] - paragraph [0017] * ----- | 3-5,13, 14 | |
| X | WO 2005/090852 A (LIGHTING SCIENCE GROUP CORP [US]; MAXIK FREDRIC S [US]) 29 September 2005 (2005-09-29) * page 7, line 1 - page 12, line 13 * ----- | 3-5,13, 14 | |
| X | GB 2 360 461 A (PHOTO THERAPEUTICS LTD [GB]) 26 September 2001 (2001-09-26) * page 5, line 16 - line 21; figure 3 * ----- -/-- | 6,7,10, 13,14 | |
| The present search report has been drawn up for all claims | | | |
| Place of search Munich | | Date of completion of the search 4 September 2007 | Examiner VILLAFUERTE ABREGO |
| CATEGORY OF CITED DOCUMENTS X : particularly relevant if taken alone Y : particularly relevant if combined with another document of the same category A : technological background O : non-written disclosure P : intermediate document | | T : theory or principle underlying the invention E : earlier patent document, but published on, or after the filing date D : document cited in the application L : document cited for other reasons & : member of the same patent family, corresponding document | |

3
EPO FORM 1503 03.02 (P04C01)



| DOCUMENTS CONSIDERED TO BE RELEVANT | | | |
|---|--|---|---|
| Category | Citation of document with indication, where appropriate, of relevant passages | Relevant to claim | CLASSIFICATION OF THE APPLICATION (IPC) |
| E | US 7 165 863 B1 (THOMAS JAMES G [US] ET AL) 23 January 2007 (2007-01-23) * column 5, line 58 - column 6, line 46 * ----- | 6,7,10,13,14 | |
| X | ES 2 255 885 A1 (FERNANDEZ DE VALDERRAMA ALVARE [ES]; FERNANDEZ DE VALDERRAMA SAN MI) 1 July 2006 (2006-07-01) * column 6, line 20 - line 57 * ----- | 8,9,11-14 | |
| The present search report has been drawn up for all claims | | | TECHNICAL FIELDS SEARCHED (IPC) |
| | | | |
| Place of search Munich | | Date of completion of the search 4 September 2007 | Examiner VILLAFUERTE ABREGO |
| CATEGORY OF CITED DOCUMENTS X : particularly relevant if taken alone Y : particularly relevant if combined with another document of the same category A : technological background O : non-written disclosure P : intermediate document | | T : theory or principle underlying the invention E : earlier patent document, but published on, or after the filing date D : document cited in the application L : document cited for other reasons & : member of the same patent family, corresponding document | |

3
EPO FORM 1503 03.02 (P04C01)

**CLAIMS INCURRING FEES**

The present European patent application comprised at the time of filing more than ten claims.

- Only part of the claims have been paid within the prescribed time limit. The present European search report has been drawn up for the first ten claims and for those claims for which claims fees have been paid, namely claim(s):
- No claims fees have been paid within the prescribed time limit. The present European search report has been drawn up for the first ten claims.

LACK OF UNITY OF INVENTION

The Search Division considers that the present European patent application does not comply with the requirements of unity of invention and relates to several inventions or groups of inventions, namely:

see sheet B

- All further search fees have been paid within the fixed time limit. The present European search report has been drawn up for all claims.
- As all searchable claims could be searched without effort justifying an additional fee, the Search Division did not invite payment of any additional fee.
- Only part of the further search fees have been paid within the fixed time limit. The present European search report has been drawn up for those parts of the European patent application which relate to the inventions in respect of which search fees have been paid, namely claims:
- None of the further search fees have been paid within the fixed time limit. The present European search report has been drawn up for those parts of the European patent application which relate to the invention first mentioned in the claims, namely claims:



The Search Division considers that the present European patent application does not comply with the requirements of unity of invention and relates to several inventions or groups of inventions, namely:

1. claims: 1-2

Performance optimisation method of lighting devices with selected orientation of:

- LED light sources,
- secondary optics,

using S/W assisted calculations.

2. claims: 3-5, 13-14

Lighting devices manufacturing method with:

- LED light sources;
- 3D base structures;
- semi-flexible PCB;
- 3D position and orientation of the the LEDs.

3. claims: 6-7, 10, 13-14

Lighting devices manufacturing method with:

- LED light sources;
- heat-sink;
- PCB;
- electronic components
- protection/tightness features;
- mechanical structure with:
 - main structure;
 - protector structure;
 - chimney zone.

4. claims: 8-9, 11-12, 13-14

Lighting apparatus and control method with:

- LED light sources;
- semi-flexible PCB;
- optical means;
- direction of the the LEDs;
- SW regulated power feed.

ANNEX TO THE EUROPEAN SEARCH REPORT
ON EUROPEAN PATENT APPLICATION NO.

EP 07 10 0432

This annex lists the patent family members relating to the patent documents cited in the above-mentioned European search report. The members are as contained in the European Patent Office EDP file on
The European Patent Office is in no way liable for these particulars which are merely given for the purpose of information.

04-09-2007

| Patent document cited in search report | Publication date | Patent family member(s) | Publication date |
|--|------------------|--|--|
| WO 9950596 A | 07-10-1999 | AU 3347699 A RU 2137978 C1 | 18-10-1999 20-09-1999 |
| JP 11329022 A | 30-11-1999 | NONE | |
| US 2003193807 A1 | 16-10-2003 | NONE | |
| JP 2005196983 A | 21-07-2005 | NONE | |
| US 2007019432 A1 | 25-01-2007 | JP 2007030619 A | 08-02-2007 |
| US 2003090910 A1 | 15-05-2003 | TW 533750 B | 21-05-2003 |
| US 2005254264 A1 | 17-11-2005 | EP 1614956 A2 JP 2005327731 A KR 20060043589 A | 11-01-2006 24-11-2005 15-05-2006 |
| WO 2005090852 A | 29-09-2005 | US 2005207152 A1 | 22-09-2005 |
| GB 2360461 A | 26-09-2001 | AT 276014 T AU 781077 B2 AU 2980701 A CA 2341951 A1 DE 60105473 D1 DE 60105473 T2 DK 1138349 T3 EP 1138349 A2 EP 1457234 A2 ES 2228756 T3 GB 2360459 A GB 2360460 A GB 2370992 A JP 2002065875 A JP 2005334670 A US 2004127961 A1 US 2002029071 A1 | 15-10-2004 05-05-2005 27-09-2001 23-09-2001 21-10-2004 17-11-2005 24-01-2005 04-10-2001 15-09-2004 16-04-2005 26-09-2001 26-09-2001 17-07-2002 05-03-2002 08-12-2005 01-07-2004 07-03-2002 |
| US 7165863 B1 | 23-01-2007 | US 2007115666 A1 | 24-05-2007 |
| ES 2255885 A1 | 01-07-2006 | NONE | |