

J. F. KERNS.
MOTOR FOR PROPELLING BOATS.

(Application filed Mar. 8, 1901.)

(No Model.)

2 Sheets—Sheet 1.

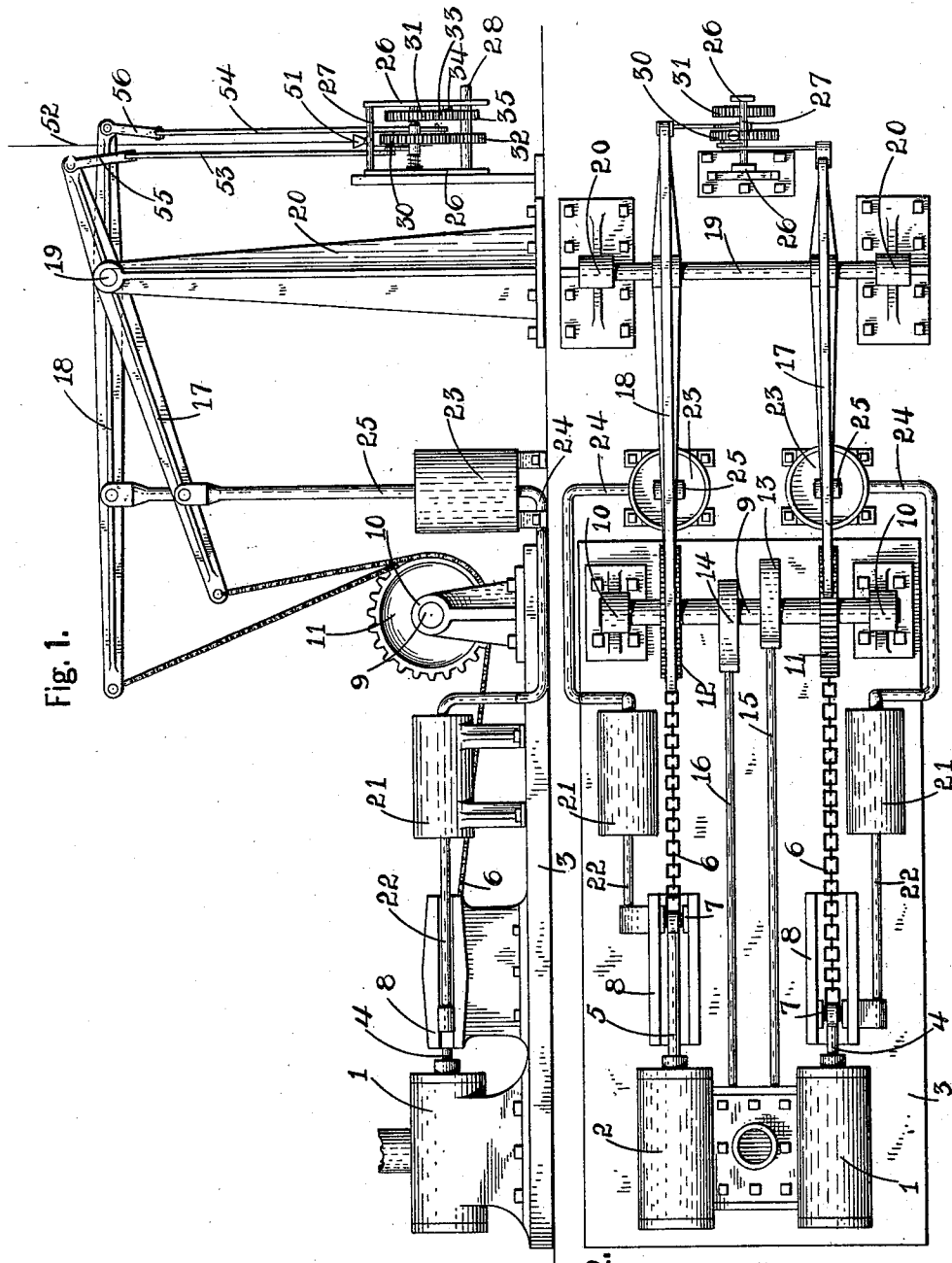

Fig. 1.

Fig. 2.

Witnesses.

L. M. Billings.
Geo. A. Heubauer.

Inventor.

John F. Kerns.
By A. J. Saugster.
Attorney.

J. F. KERNS.
MOTOR FOR PROPELLING BOATS.

(Application filed Mar. 8, 1901.)

(No Model.)

2 Sheets—Sheet 2.

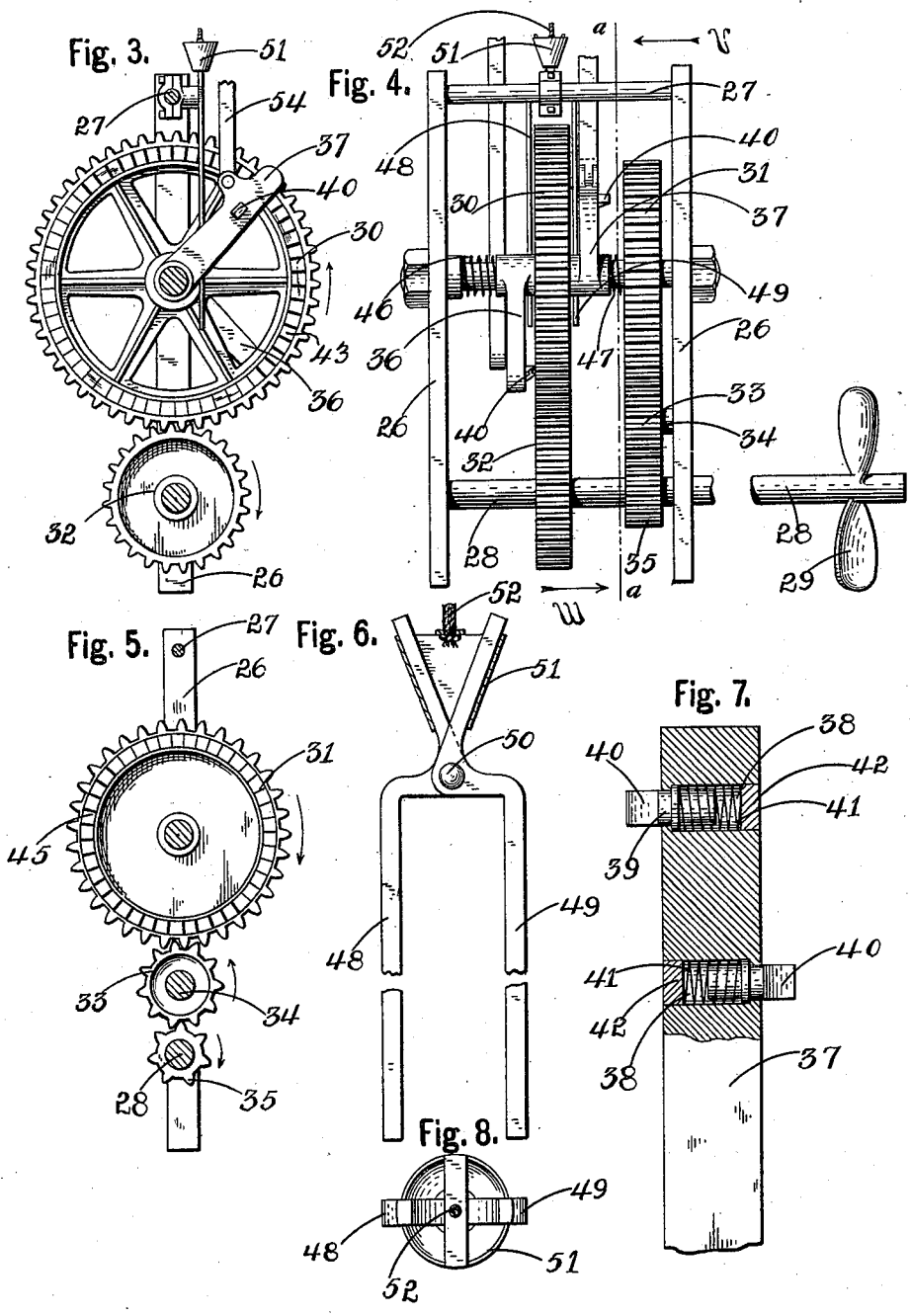

Witnesses.

L. M. Billings
Geo. A. Neubauer.

Inventor.

John F. Kerns.
By *A. J. Sangster*
Attorney.

UNITED STATES PATENT OFFICE.

JOHN F. KERNS, OF BUFFALO, NEW YORK.

MOTOR FOR PROPELLING BOATS.

SPECIFICATION forming part of Letters Patent No. 687,241, dated November 26, 1901.

Application filed March 8, 1901. Serial No. 50,813. (No model.)

To all whom it may concern:

Be it known that I, JOHN F. KERNS, a citizen of the United States, residing at Buffalo, in the county of Erie and State of New York, have invented certain new and useful Improvements in Motors for Propelling Boats, of which the following is a specification.

My invention relates to an improved means for propelling boats; and one of the principal objects is to arrange a means for reversing the propelling device without stopping or reversing the power device.

It also relates to certain details of construction, and for a full understanding of the merits and advantages of the invention reference is to be had to the accompanying drawings and the following description.

The invention is susceptible to various changes in the form, proportion, and minor details of construction without departing from the principle or sacrificing any of the advantages thereof, and to a full disclosure of the invention an adaptation thereof is shown in the following drawings, in which—

Figure 1 is a side elevation of my improved means. Fig. 2 is a top plan view of my improved means. Fig. 3 is a section on line *a a*, Fig. 4, looking in the direction of the arrow *V*. Fig. 4 is an enlarged fragmentary view of the reversing-gearing. Fig. 5 is a section on line *a a*, Fig. 4, looking in the direction of the arrow *W*. Fig. 6 is an enlarged detached view of the spreading device. Fig. 7 is an enlarged fragment, partially in section, of one of the actuating crank-arms. Fig. 8 is an enlarged detached top plan view of the operating-cone and the spreading device.

Referring to the drawings in detail, like numerals designate like parts.

This invention consists of power mechanism, propelling mechanism, and mechanism for reversing the propelling mechanism without stopping or reversing the power mechanism. The preferred form of power mechanism or device is shown in Figs. 1 and 2. Two steam-cylinders 1 and 2 of any ordinary and well-known type are mounted upon a base 3. The piston-rods 4 and 5 of these cylinders are connected at their outer ends to chains 6 and have enlarged portions 7, which form slides that travel in the slideways 8. The purpose of the slideways is to prevent lat-

eral movement of the pistons. A horizontal rock-shaft 9 is journaled in boxes 10 and carries two gear-wheels 11 and 12. One of these gear-wheels is rotatable on the shaft, so that the wheels can turn in opposite directions. The gear-wheel 11 is rigid on the shaft 9 and rocks with it, and the gear-wheel 12 is mounted loosely on and rotates independently of the shaft. The valve mechanism of the steam-cylinders is operated by the oppositely-arranged cams 13 and 14 on the rock-shaft through the connecting-rods 15 and 16. Two walking-beams 17 and 18 have rocking bearing on a horizontal bar 19, mounted in the upper ends of the supports 20, and the forward end of each walking-beam is connected to one of the chains 6. Two of the chains are employed—one connecting the walking-beam 17 to the piston 4 and passing under the gear-wheel 11 and the other connecting the walking-beam 18 to the piston 5 and passing under the gear-wheel 12. The forward ends of the walking-beams are drawn downward by means of the forward movement of the pistons and are elevated by an air-actuated device. Two air-compressors 21 have their pistons 22 operatively connected to the pistons 4 and 5 of the steam-cylinders, and two upright air-pumps 23 are each connected by pipes 24 to one of the air-compressors. A vertical piston 25, arranged in each pump, is pivoted at its upper end to one of the walking-beams. The walking-beams are raised and lowered alternately by means of the above-described mechanism.

The preferable form of the propelling mechanism consists of a frame composed of two upright frame-bars 26, an upper horizontal bar or support 27, mounted in said frame 26, a lower propelling-shaft 28, journaled in the frame and having a propeller 29 at its rear end, two independent gear-wheels 30 and 31, rotatably mounted on the bar, a gear-wheel 32 on the propeller-shaft 28, meshing with the gear-wheel 30 on the bar, an idle wheel 33, journaled on a short bar 34 and meshing with the gear-wheel 31 on the upper bar, a gear-wheel 35 on the propeller-shaft 28, meshing with the idle wheel 33, and devices for oscillating the independent gear-wheels. These devices consist of two crank-arms 36 and 37 journaled on the bar and having both an os-

cillating movement and a longitudinal movement on the bar, and each arm has one or more openings 38, in which a pawl-pin 39, having a beveled outer end 40, is supported against the tension of a spring 41, the beveled end 40 of the pin normally projecting from one end of the opening and the opposite end being closed by a plug 42 to retain the spring and pin in place. (See Fig. 7.) The gear-wheels 30 and 31 are provided on their sides or faces with ratchet-teeth, the central wheel 30 being provided on both sides or faces with ratchet-teeth, (designated by the numeral 43,) and the wheel 31 having ratchet-teeth 45 on one side or face only. The crank-arm 36 has but one pawl-pin which engages with the ratchet-teeth 43 on the left-hand face of the central wheel and the crank-arm 37, which is mounted on the bar between the two wheels 30 and 31, has two pawl-pins which project from opposite sides and operate oppositely to each other. (See Fig. 7.) Both of the crank-arms are normally held in engagement with the central wheel by the coil-springs 46 and 47, mounted on the upper bar 27, and thereby rotate the propeller-wheel, so as to drive the boat forward.

Means are provided for disconnecting the crank-arms from the central wheel and operatively engaging with the other gear-wheel 31, and thereby reversing the propeller. This means preferably consists of two pivotal arms 48 and 49, pivoted together by the pivot 50 and having the lower ends fitting against the inner surface of the crank-arms and their upper ends diverging from each other and a truncated conical shell 51 fitting upon the diverging upper ends. (See Fig. 6.) An operating-rope 52 extends from the shell 51 to within convenient reach of the steerman or to any other suitable point. Pulling on the rope raises the cone, spreads the lower ends of the pivotal arms from each other, and shifts the crank-arms on the bar, thereby disengaging the pawl-pins of the crank-arms from the ratchet-faces 43 and 44 of the central wheel 30 and operatively engaging the pawl-pin projecting from the right-hand side of the crank-arm 37 with the ratchet-face 45 of the gear-wheel 31. Connecting-rods 53 and 54 connect the crank-arms to the lower ends of rods 55 and 56, which are pivotal, and their upper ends to the walking-beams and provide means for operating the trains of gearing which drive the propeller-wheel.

The operation of the device will be clearly understood from the foregoing description.

I claim as my invention—

1. A means for propelling boats comprising walking-beams, a propeller, two independent mechanisms connected to the propeller, means for operatively connecting either of said mechanisms to the walking-beams, and means for rocking the walking-beams.

2. A means for propelling boats compris-

ing walking-beams, power mechanism connected to the walking-beams, a propeller, and reversing mechanism connecting the propeller to the walking-beams.

3. A means for propelling boats comprising two steam-cylinders having pistons, two walking-beams, chains connecting the walking-beams to the pistons, two air-compressors having pistons operatively connected to the pistons of the steam-cylinders, two air-pumps operated from the air-compressors, and having piston-rods pivoted to the walking-beams, and a propeller operated by the walking-beams.

4. A means for propelling boats comprising two steam-cylinders having pistons, two walking-beams, chains connecting the walking-beams to the pistons, two air-compressors having pistons, operatively connected to the pistons of the steam-cylinders, two air-pumps operated from the air-compressors, and having piston-rods pivoted to the walking-beams, a propeller operated by the walking-beams and means for reversing the propeller without interfering with the operation of the walking-beams.

5. In a means for propelling boats, two walking-beams, means for rocking said walking-beams, a propeller, two independent trains of gearing connected to the propeller, crank-arms oscillated by the walking-beams and means for shifting the crank-arms to operatively connect with either train of gearing.

6. In a means for propelling boats, two walking-beams, means for rocking said walking-beams, a propeller having a shaft, two gear-wheels on the propeller-shaft, two upper gear-wheels; one meshing with one of the gear-wheels on the propeller-shaft, an idle gear-wheel interposed between and meshing with the other upper gear-wheel and the other gear-wheel on the propeller-shaft, crank-arms oscillated by the walking-beams, and means for shifting the crank-arms to operatively engage either of the upper gear-wheels, substantially as described.

7. In a means for propelling boats, two walking-beams, means for rocking said walking-beams, a propeller having a shaft, two gear-wheels on the propeller-shaft, two upper gear-wheels having ratchet-toothed sides; one meshing with one of the gear-wheels on the propeller-shaft, an idle gear-wheel interposed between and meshing with the other upper gear-wheel and the other gear-wheel on the propeller-shaft, crank-arms oscillated by the walking-beams, pawl-pins carried by the crank-arms, and means for shifting the crank-arms to bring the pawl-pins in operative contact with the ratchet-faces of either of the upper gear-wheels substantially as described.

8. In a means for propelling boats, two walking-beams, means for rocking said walking-beams, a propeller having a shaft, two gear-wheels on the propeller-shaft, two upper gear-wheels; one meshing with one of the gear-

wheels on the propeller-shaft, an idle gear-wheel interposed between and meshing with the other upper gear-wheel and the other gear-wheel on the propeller-shaft, crank-arms oscillated by the walking-beams, springs for maintaining the crank-arms in operative position relatively to one of the upper gear-wheels and means for shifting the crank-arms to disengage said upper gear-wheel and operatively engage the other upper gear-wheel.

9. In a means for propelling boats, two walking-beams, means for rocking said walking-beams, a propeller having a shaft, two gear-wheels on the propeller-shaft, two upper gear-wheels; one meshing with one of the gear-wheels on the propeller-shaft, an idle gear-wheel interposed between and meshing with the other upper gear-wheel and the other gear-wheel on the propeller-shaft, crank-arms oscillated by the walking-beams, springs for maintaining the crank-arms in operative position relatively to one of the upper gear-wheels and a spreading device for shifting the crank-arms to disengage said upper gear-

wheel and operatively engage the other upper gear-wheel.

10. In a means for propelling boats, two walking-beams, means for rocking said walking-beams, a propeller having a shaft, two gear-wheels on the propeller-shaft, two upper gear-wheels; one meshing with one of the gear-wheels on the propeller-shaft, an idle gear-wheel interposed between and meshing with the other upper gear-wheel and the other gear-wheel on the propeller-shaft, crank-arms oscillated by the walking-beams, springs for maintaining the crank-arms in operative position relatively to one of the upper gear-wheels and a pair of pivotal spreading arms having their lower ends against the crank-arms and their upper ends converging, a conical shell on the converging upper ends, and means for elevating the conical shell, substantially as described.

JOHN F. KERNS.

Witnesses:

L. M. BILLINGS,
A. J. SANGSTER.