



US 20090119825A1

(19) **United States**

(12) **Patent Application Publication**  
**Wilson et al.**

(10) **Pub. No.: US 2009/0119825 A1**

(43) **Pub. Date: May 14, 2009**

(54) **LAVATORY CLEANSING BLOCK**

(30) **Foreign Application Priority Data**

(76) Inventors: **Brian Wilson**, Norfolk (GB);  
**David Stuart**, Glasgow (GB)

Dec. 31, 2004 (GB) ..... 0428559.9

**Publication Classification**

Correspondence Address:  
**OSTROLENK FABER GERB & SOFFEN**  
**1180 AVENUE OF THE AMERICAS**  
**NEW YORK, NY 100368403**

(51) **Int. Cl.**  
**E03D 9/02** (2006.01)

(52) **U.S. Cl.** ..... 4/222

(57) **ABSTRACT**

(21) Appl. No.: **11/813,182**

(22) PCT Filed: **Jan. 3, 2006**

(86) PCT No.: **PCT/GB06/00024**

§ 371 (c)(1),  
(2), (4) Date: **Mar. 14, 2008**

A lavatory cleansing block has two parts. The formulations of each part are such that one part has a substantially shorter in-use life time than the other part. The faster dissolving part may provide a different active ingredient to the lavatory bowl or an increased impact, such as foam level or smell, for the user. A cleansing block comprising a colorant and less than 5% by weight is also claimed. Apparatus for making a lavatory cleansing block comprising means for forming a body formed from a first composition, the body having at least one aperture there through.

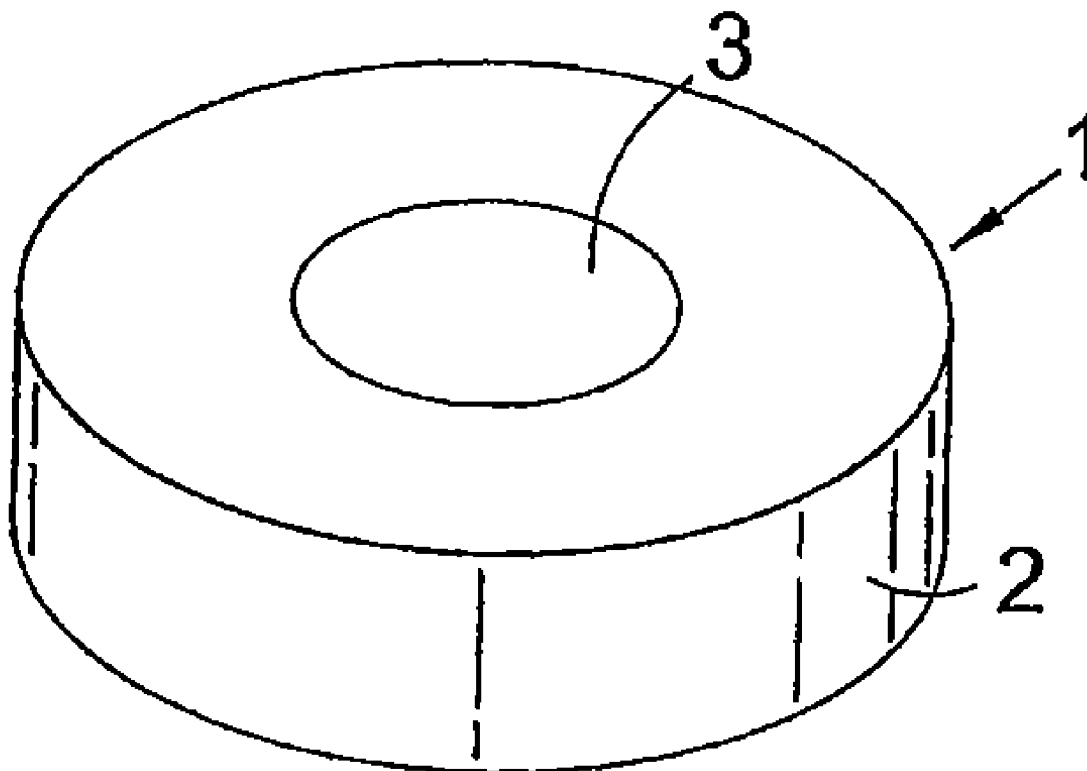

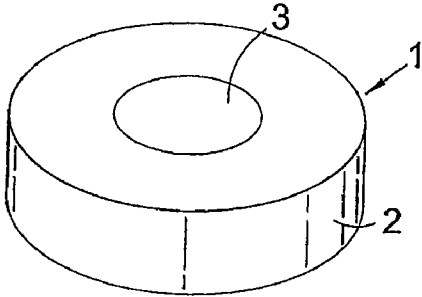

Fig. 1

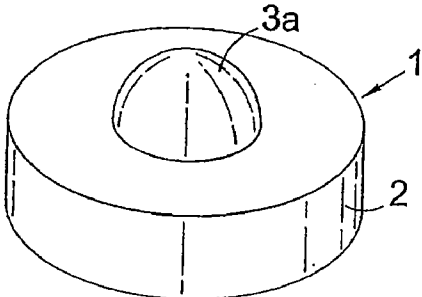

Fig. 4

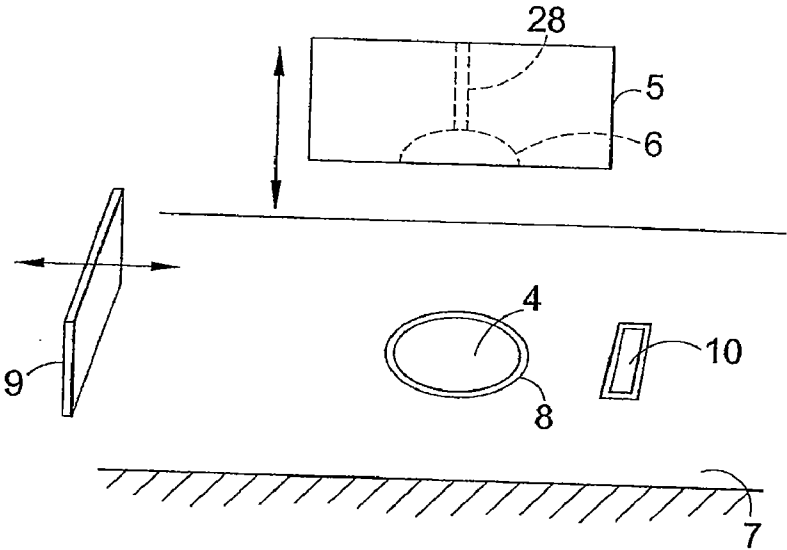

Fig. 2

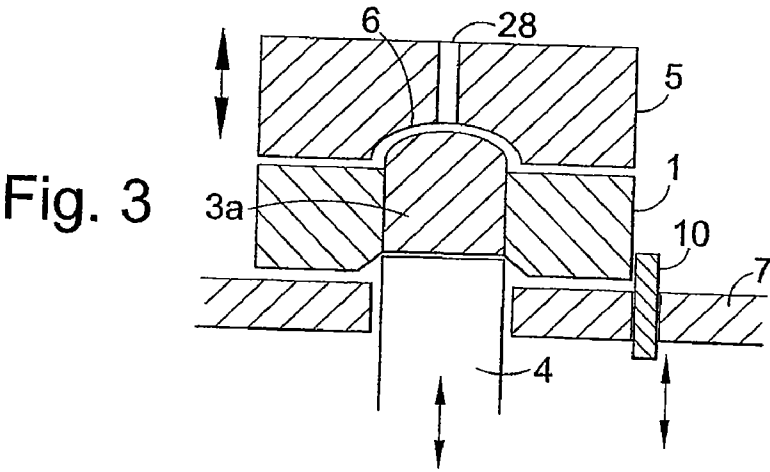

Fig. 3

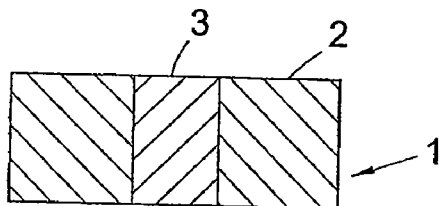

Fig. 5a

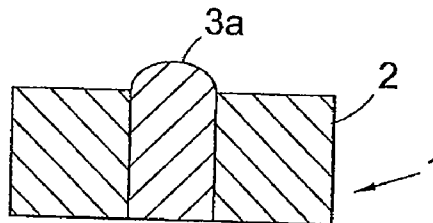

Fig. 5b

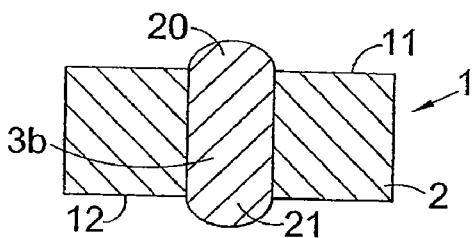

Fig. 5c

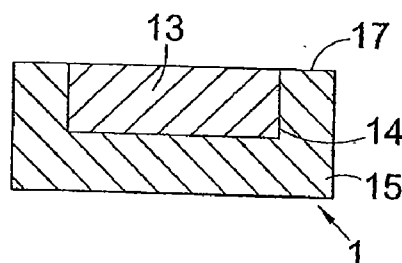

Fig. 5d

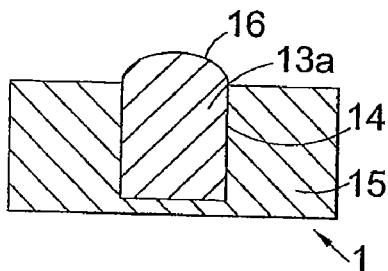

Fig. 5e

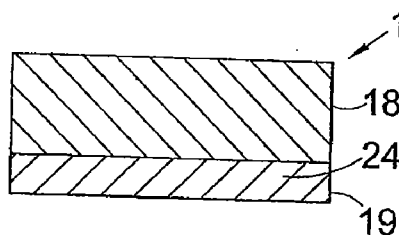

Fig. 5f

### LAVATORY CLEANSING BLOCK

**[0001]** The present invention relates to a lavatory cleansing block.

**[0002]** Typically, lavatory cleansing blocks are immersed in the water cistern of a lavatory (an in-tank or in-cistern block), or held in a cage under the rim of the lavatory bowl (a rim block), or sometimes in a cage on the top of the cistern, in Japan for example, (an on-tank block). The block dissolves slowly, releasing active ingredients into the lavatory bowl.

**[0003]** Generally such blocks may contain as active ingredients one or more of:

**[0004]** i) a surface active agent to provide a cleansing effect, and also to provide foam as an indicator to the user;

**[0005]** ii) a bleach component;

**[0006]** iii) a colourant primarily as an indicator to the user;

**[0007]** iv) a perfume;

**[0008]** v) a germicide;

**[0009]** vi) limescale controller

**[0010]** It will be appreciated that the extent to which the block provides a cleansing action pre se depends on the active ingredients used and the quantity dosed into the lavatory bowl during a flush cycle.

**[0011]** The block will also contain processing aids to assist in manufacture of the block by extrusion, tableting, etc, fillers and also solubility controllers to control the lifetime of the block.

**[0012]** The in use life of the block is governed in particular by the amount of material in the block and the rate at which the block dissolves in the flush water and this depends primarily on the composition of the block.

**[0013]** Also, the block life will depend in part on the hardness of the flush water, the ambient temperature, the frequency of flushing and even the toilet design. These factors are well known in the art and the block composition can be tested against a range of conditions when determining a suitable composition for a particular market.

**[0014]** The quantity of active ingredients delivered into the toilet bowl during each flush cycle of the toilet will in turn affect the actual and perceived performance of the block: for example the action of a surfactant or bleach to cleanse the toilet bowl, and the appearance of foam or dye to the user, or perception of a fragrance.

**[0015]** For typical domestic use, the preferred life of the block is about 28 days. For some applications, an in use lifetime of several months is required.

**[0016]** It is difficult to balance the effective and/or perceived cleansing performance against the desired block life, while maintaining a viable or economic block size and an even block performance over the major portion of the lifetime of the block.

**[0017]** By the rate at which a block part dissolves we mean the effective lifetime of the block or block part in use, not the absolute rate at which a component goes into solution. The dissolution of the block part, i.e. the end of life, can be measured in a number of ways. Visual inspection of the block part is often a good indicator, and the end of life of the block or block portion can be taken to be when there are no visible remains of the block.

**[0018]** In some very hard water environments, the fillers or solubility control agents may remain in place in the toilet

cistern or the block cage after the active ingredients have been exhausted, thus making a visible determination more difficult. Another approach to determining lifetime is to remove the block part and measure the fall in the active ingredient content. Another way of measuring the end of life of the block part is to detect a fall off in the concentration of the active ingredients in the flush water. This can be a simple visual test—for example there is no longer any foam in the toilet flush water, any visual colourisation or any smell—or by a chemical analytical test. Thus, for example, if the amount of an active ingredient in the block part of the flush water falls to less than 90% of an initial value, it can be assumed that the block part has reached or is very close to its effective end of life. When measuring the concentration of the active component in the flush water it will be appreciated by those in the art that this will depend in part on the length of time between flushes.

**[0019]** A first aspect of the present invention provides a lavatory cleansing block comprising a body having two parts formed from respective compositions, wherein, in use, one part dissolves substantially more rapidly than the other part. The block may have more than two parts, each formed of a respective composition, and each having a substantially different in use lifetime.

**[0020]** In a particularly preferred form, a faster dissolving block part is provided in a recess or aperture in a slower dissolving block part. Thus, when the one block part is dissolved, the exposed surface area of the other block part is increased. This will tend to increase the rate at which the other block part dissolves.

**[0021]** A plurality of one or both block parts may be provided. For example, the composition of one block part may be provided in a plurality of apertures and/or recesses in the second block part.

**[0022]** The compositions of the block parts dissolve at different rates. In one embodiment, the one block part dissolves over a short period of time and produces a relatively higher concentration of active ingredients in the flush water to give greater cleaning and/or fragrancing, or other desired performance benefit, such as limescale control, bleaching, disinfection and/or colour. The other block part produces a lower concentration of active ingredients in the flush water over the block's in-use life.

**[0023]** We particularly prefer to utilise our invention with an in-tank block, although in the bowl blocks and on-tank blocks may also be formulated.

**[0024]** The perceived benefit of a block can be as important as the actual effect of the active ingredients, such as the cleansing power of the block, in determining the commercial success of a block. Accordingly, the composition which dissolves more rapidly, i.e. has a shorter in-use lifetime, preferably comprises an active ingredient such as perfume, colourant or a foam-producing surfactant to increase the perceived initial cleansing power or activity of the block.

**[0025]** The different block parts may provide different active ingredients into the flush water. Thus, for example, one block part may provide a high concentration of a limescale control agent or a bleach, and the other block part a surfactant. One or both block parts may contain a colorant to dye the flush water to indicate to the user that the block is active. The block parts may have different colour colourants or provide a different dosage of colourant to the flush water to produce different colour intensity. Preferably the faster dissolving

block part provides more intense colour, such as by providing a higher concentration of colourant, to the flush water.

**[0026]** The block part which dissolves more rapidly may comprise a component which accelerates dissolution. Such a component may comprise citric acid and/or sodium bicarbonate. These ingredients accelerate dissolution and they may also create visible effervescence or bubbling from the block, thereby increasing the perceived initial performance of the block. The composition may comprise a relatively low content of less soluble components such as salts, fillers and hydrophobes to facilitate more rapid dissolution.

**[0027]** The composition which dissolves less rapidly may comprise a relatively higher proportion of a solubility control agent such as hydrophobes or salts to retard dissolution.

**[0028]** We particularly prefer that the faster dissolving component provide a higher impact on the user compared to the other component such as by delivering a relatively high bleach concentration or surfactant concentration into the toilet bowl, which will be readily noticed by the user for a short period, for example one to three days, as indicating an effective initial cleansing action. It may also be possible to use an active ingredient which may give an indication, such as smell or colour, which is too strong for a user to tolerate over a block life of four weeks, say, but will be tolerated for a few days.

**[0029]** In general, we have found that conventional block ingredients may be used for the block parts. The ingredients are selected according to the desired properties of the block part (e.g. bleaching, foaming, fragrancing, anti-limescale, etc), and block lifetime. The relative amounts of the ingredients and the weight of the block parts are adjusted to provide the desired concentration of active ingredients into the flush water and to provide the desired in-use lifetime.

**[0030]** Solubility control agents which retard dissolution are well known. Examples include saturated organic materials or highly chlorinated organic materials. Examples of solubility agents which may be employed include polyethylene waxes; fatty alcohols; fatty acids; low ethoxylates (e.g. containing up to 4 ethylene oxide units per mole) of fatty alcohols and alkylphenols; paradichlorobenzene; and esters which resist hydrolysis such as methyl salicylate and isobornyl acetate.

**[0031]** A surface active agent (surfactant) may be included in either or both of the compositions of block parts. The same surface active agent may be used in each composition, or different agents may be used. More than one surface active agent may be used in each composition. Typical surface active agents include anionics such as alkali metal paraffin sulphonates, alkali metal alkyl sulphates and alkyl aryl sulphonates, particularly alkyl benzene sulphonates. Preferably the total concentration of surface active agent is from about 5 to about 75% by weight of the block part, preferably about 20 to about 60%, and more preferably about 30 to about 50%. The amounts refer to the amount of active surface active agent. In the following examples we specify the weight percent of the surface active agent composition. Typically a surface active agent is supplied as X % active, i.e. X % of the composition is the required surface active agent, and so 100 g of an '80% active' surface active agent composition would provide 80 g of surface active agent.

**[0032]** The concentration of surface active agent in the composition which dissolves less rapidly may be greater than the concentration of surface active agent in the composition which dissolves more rapidly in order to ensure satisfactory maintenance cleaning.

**[0033]** A bleach may be included in either or both of the two compositions. Preferably the bleach is a halogen release agent. Preferably the halogen release agent is a chlorine release agent, more preferably a chlorinated cyanuric acid derivative such as sodium dichloroisocyanurate. Preferably the bleaching agent is present in an amount of from 2 to 75% by weight of the block part, preferably 5 to 60% and more preferably 10 to 40% by weight. Where a perfume or colourant which is not bleach-stable is used, bleach is preferably included in only one of the two compositions. The perfume and/or colourant may then be included in the other composition.

**[0034]** A colourant may be included in either or both of the two compositions. As noted above, if the colourant is not bleach-stable, then it is preferably included in a composition which does not include bleach. The colourant may provide colour to the flush water if a sufficient amount is dispersed during a flushing operation, but the colourant also provides an attractive appearance to the finished block when it is on-shelf. In addition, if a different colourant is used for the two compositions, the colourant will provide a visual distinction between the two compositions.

**[0035]** A perfume may be included in either or both of the two compositions. As noted above, if the perfume is not bleach-stable, then it is preferably included in a composition which does not include bleach. The perfume is preferably present in an amount of from about 0.5 to about 15% by weight of the final block part, preferably about from 2 to about 10%, and more preferably from about 3 to about 7% by weight. Where the perfume includes a carrier oil, we include the carrier oil in the % wt noted above.

**[0036]** Other components of the block may include processing aids, fillers, and water softening agents, as known in the art. It will be appreciated that each part of the block will, because of the different active components, impose different constraints on the required processing aids etc.

**[0037]** The slower dissolving block part, that is the block part having the longer in-use lifetime, will usually be of higher volume and a solid to enable the block to be handled, but the composition having a shorter in-use lifetime, may be a solid, a gel or liquid. A gel or liquid may be encapsulated in a water soluble sac or capsule. The block parts may be separate but very preferably the block parts are integrated to form a single unit for handling by the user.

**[0038]** Preferably, the faster dissolving block part is held as a core in the body of the other block part. The core will then dissolve before the body. As the core dissolves, the exposed surface area of the body will increase, with the result that the rate of dissolution of the slower-dissolving body will increase after the one block part has been dissolved.

**[0039]** The core may project from at least one side of the block in order to provide a visual distinction between the core and the body and also increase the surface area in contact with the flush water.

**[0040]** The rate at which the body and core dissolve will be determined not only by the inherent solubility of the active ingredients and the impact of the solubility control agents in the first and second compositions, but also by the shape and relative dimensions of the body and core and the surface areas exposed to the flush water, and also the quantity of material including the weight of material and the degree of compaction.

**[0041]** As noted above, other environmental factors affect the in-use lifetime of a block or block part, such as water

hardness, flush frequency, temperature, toilet type. In producing a toilet block, the manufacturer will aim for a particular lifetime in a typical set of conditions, and tailor the block composition to the average or typical conditions in a market, as is well known in the art. Thus, a different block formulation may be used for non-temperate climates compared to temperate ones, for soft water areas compared to hard water areas, etc.

**[0042]** Thus one measure of block life utilises a UK style, 9 litre flush toilet cistern with a domestic flush pattern of 17 flushes per day, at 10 to 12 degrees centigrade, and 250 ppm water hardness measured as Calcium Carbonate, to simulate the typical lifetime expected in a UK environment, but the parameters may be varied to suit other environments, as well known in the art. The block formulation, particularly the solubility control agents, will be varied to produce the desired lifetime of each component, and the active ingredient quantity varied to produce the desired dosing of active ingredient into the toilet cistern.

**[0043]** For example, the composition of the first and second block parts and the weight, shape and dimensions may be selected so that, when the block is in use, one block part dissolves in less than one week, preferably, in between one to three days, and the other block part dissolves in one week or more, preferably in three weeks or more.

**[0044]** Preferably, the block parts are co-extruded. In another embodiment, the block parts are formed separately and joined together, for example by pressing together.

**[0045]** EP-A-55100 shows, for example, a tablet of bleaching agent embedded in a toilet cleansing block. GB-A-2333778 and DE-A-4439677 show co-extruded blocks of two compositions and also U.S. Pat. No. 4,578,207. Thus it will be appreciated that a variety of shapes of block may be provided. Each composition may occupy a respective single region of the block. The same composition may be distributed in two or more discrete regions of the block.

**[0046]** We have found that the performance of the two block parts is not always simply additive. In particular, if a gassing agent such as citric acid or sodium bicarbonate is used to cause rapid dissolution of one block part, this may cause more rapid dissolution of the adjacent regions of the other block part. Conversely, as the volume of the one block part diminishes, there is a risk of the other block part swelling or flowing to cover the one block part, slowing dissolution of the one part.

**[0047]** When one block part is surrounded by the other block part, then it is preferably that the one block part does not swell substantially in use, otherwise it may break up the surrounding first block part.

**[0048]** One block part may completely surround the other block part. Thus, the one block part will dissolve over a period of time before exposing the other block part to dissolution. Either block part may be configured to dissolve more rapidly than the other. Thus the outer block part may dissolve over a longer period, for example one to four weeks, before exposing the inner block part which will dissolve over a shorter period, for example one to three days. The inner block part may produce an increased concentration of active ingredient in the flush water and/or it may introduce a different active ingredient, to signify the end of block life and to give a boost to the perceived action of the block.

**[0049]** For ease of manufacture and formulation we prefer a block utilising only two formulations or parts, though a part may be separated into discrete regions.

**[0050]** A block having more than two formulations or parts may be produced, and they may be tailored to deliver different active components and/or to have different in-use lifetimes.

**[0051]** In one preferred formulation a two part lavatory cleansing block has:

**[0052]** in the first part from 40 to 80% by weight of surfactant, preferably 45 to 55%, from 10 to 30% by weight of polyacrylate, preferably from 15 to 25%; and 0 to 20% by weight of hydrophobe, preferably from 5 to 15%; and

**[0053]** in the other part from 65 to 85% by weight of surfactant, preferably from 70 to 80%; from 0 to 20% by weight of hydrophobe, preferably from 5 to 15%.

**[0054]** Preferably the hydrophobe is pine oil. Other preferred hydrophobes include C9-C11 primary alcohols and non-ionic surfactants. These act also as processing aids.

**[0055]** In another preferred formulation a two part lavatory cleansing block has:

**[0056]** in the first part from 40 to 80% by weight of surfactant, preferably 45 to 55%, from 10 to 30% by weight of polyacrylate, preferably from 15 to 25%; and 0 to 20% by weight of hydrophobe, preferably from 5 to 15%; and

**[0057]** in the other part from 15 to 35% by weight of surfactant, preferably from 20 to 30%; from 30 to 60% by weight of filler, preferably from 35 to 55%, and from 0 to 15% of a gassing agent, preferably 6 to 11%.

**[0058]** Preferably the hydrophobe is pine oil. Preferably the filler is a salt such as sodium sulphate. Preferably the gassing agent is citric acid and a bicarbonate.

**[0059]** According to a further aspect of the invention, there is provided an apparatus for making a lavatory cleansing block comprising means for forming a body formed from a first composition, the body having at least one aperture therethrough.

**[0060]** The apparatus may further comprise means for forming a core formed from a second composition, the core being contained in the aperture.

**[0061]** The apparatus may comprise means for shaping the core so that the core projects from the body in order to provide a visual distinction between the core and the body. The means for shaping the core may comprise a stamp for applying a force to one end of the core. The means for shaping the core may also comprise a mould for shaping the other end of the core. The apparatus may comprise means for preventing the block from sticking to the stamp and/or mould such as means for cooling the block, or means for coating the block.

**[0062]** According to another aspect of the invention, there is provided an apparatus for making a lavatory cleansing block comprising means for shaping the core so that the core projects from the body.

**[0063]** According to yet another aspect of the invention, there is provided a method of making a lavatory cleansing block, comprising forming a body formed from a first composition, the body having at least one aperture therethrough.

**[0064]** Other aspects and preferred features of the invention will be apparent from the following description and the accompanying claims. The invention will be further described by way of example, with reference to the accompanying drawings of which:

**[0065]** FIG. 1 shows a first embodiment of a block according to the invention;

**[0066]** FIG. 2 shows an apparatus according to the invention in a first operative position;

[0067] FIG. 3 shows in cross-section the apparatus of FIG. 2 in a second operative position to shape a block core;

[0068] FIG. 4 shows an embodiment of a shaped block according to the invention; and

[0069] FIGS. 5a to 5f show some examples of other block shapes which may be used in embodiments of the invention.

#### EXAMPLE 1

[0070] A two component block was produced from the following compositions:

First Composition (wt %) Slower Dissolution (B119)

[0071] (80% active) Sodium alkyl benzene sulphate 30%

(92% active) Secondary alkane sulfonate 10%

Magnesium sulfate 10%

Dye acid blue 9-3%

[0072] Hydrophobe—pine oil—6%

[0073] Filler (sodium sulfate) to 100%

Second Composition (wt %) Faster Dissolution

[0074] (80% active) Sodium ABS 7%

(92% active) Secondary alkane sulfonate 24%

Citric acid 4%

Sodium bicarbonate 5%

Perfume 5%

[0075] Filler (sodium sulphate) to 100%

[0076] The two compositions are prepared, and then co-extruded. The first composition is extruded to form a cylindrical body having a diameter of about 45 mm. The body has a circular aperture therethrough having a diameter of about 20 mm. The second composition is co-extruded with the first composition to form a cylindrical core which fills the aperture.

[0077] The cylindrical body is then cut into lengths to form blocks having a depth of about 20 mm. As shown in FIG. 1, each block 1 has an outer body 2 and a core 3.

[0078] The blocks 1 may then be coated or wrapped in a water soluble film such as polyvinylalcohol (PVA) film, and then packed in an outer packaging, such as a cardboard and plastics blister pack, for transport and on-shelf storage. In use, the wrapped block is removed from the outer packaging and dropped into the toilet cistern, i.e. used as an in-tank block.

[0079] Alternatively, the blocks 1 may be transferred to the shaping apparatus shown in FIGS. 2 and 3 for shaping before or, preferably, after wrapping with the water soluble film.

[0080] The shaping apparatus includes a cylindrical stamp 4 and a mould 5. The mould 5 includes a hemi-spherical recess 6 in its underside for shaping the core 3 of a block 1 and a vent hole 28. The stamp 4 has approximately the same diameter as the core 3, as does the open end of the recess 6.

[0081] The apparatus includes a chute 7 having a circular aperture 8 formed therein. The aperture 8 has a diameter slightly larger than the diameter of the stamp 4.

[0082] The stamp 4 is reciprocally mounted beneath the aperture 8 of the chute 7 so that it can be moved between a first position in which the upper surface of the stamp is flush with the chute 7, and a second position in which the stamp 4 projects through the aperture 8 of the chute 7.

[0083] The mould 5 is reciprocally mounted above the aperture 8 of the chute 7 so that it can be moved into contact with a block 1 which is in the stamping position. The recess 6 of the mould 5 is vertically aligned with the stamp 4.

[0084] The apparatus also includes a pusher 9 for moving a block 1 so that the core 3 is accurately positioned above the stamp 4 and below the recess 6 of the mould 5.

[0085] In use the stamp 4 is moved to its first position in which the upper surface of the stamp 4 is flush with the chute 7. The pusher 7 moves a block 1 so that its core 3 is positioned above the stamp 4 and below the aperture 6 of the mould 5. A retractable stop 10 may be provided downstream of the stamp 4 to accurately locate the block. The mould 5 is then lowered so that the lower surface of the mould 5 rests against the upper surface of the block 1. The stamp 4 is then raised into its second position in which it projects through the aperture 8 in the chute 7, and so applies a force to the lower end of the core 3. The upper end of the core 3 is pushed through the body 1 and into the recess 6 in the mould 5, which moulds the projecting end of the core 3 into a hemispherical shape. The stamp 4 and mould 5 are then retracted to their initial positions, and the block 1 is moved away from the stamping position. During this process the inner core 3 may be compacted, and there may also be some compaction of the outer block 2 if the mould 5 presses sufficiently on to the block.

[0086] After shaping, the blocks 1 may be coated or wrapped in a water soluble film such as PVA film, if this has not already been done.

[0087] As shown in FIG. 4, stamping the block provides a visual distinction between the body 2 and the core 3 of the block 1. Alternatively or in addition, a visual distinction may be provided by using different colours for the two compositions.

[0088] The apparatus may include means (not shown) for preventing the block from sticking to the stamp 4 and mould 5. These means may comprise means for cooling the block or means for coating the block. The coating may comprise a powder coating (e.g. talc), or may comprise a film coating. If a film coating is used, the film is preferably water soluble so that it can be left in place by the user and will dissolve when the block is used in a lavatory. The water soluble film may include pinholes to help ensure that the film adheres to the block 1 and does not "bubble" up when the core is compressed between the stamp 4 and mould 5. The mould may be heated, preferably to about 80 degrees centigrade, and has also been found to inhibit the formation of air bubbles under the wrapping.

[0089] It will be appreciated that other shapes may be provided for the exterior of the block 1 and for the core 3.

[0090] FIGS. 5a and 5b show cross-sections through the blocks of FIGS. 1 and 4 respectively.

[0091] In FIG. 5c the core 3b extends above and below the major surfaces 11, 12 of the outer part 1, forming a hemispherical protuberance at each end 20, 21 of the core 3b.

[0092] In FIG. 5d one block part 13 is provided in a recess 14 in a major surface 17 of the other block part 15. In FIG. 5e, the block part 13a is provided with a dome 16 which extends above the upper surface 17 of the outer block part 15.

[0093] In the embodiments the cores 3, 3a, 13, 13a are the faster dissolving block parts, that is they have a shorter in use lifetime. However, the outer parts 1 could be formulated to be the faster dissolving part.

[0094] In FIG. 5f, the block is formed by two contiguous block parts 18, 19.

#### EXAMPLES 2 TO 4

[0095] Faster dissolving block parts suitable for forming the core of 3, 3a, 13, 13a embodiments shown in FIGS. 1 and 2 and 5a to 5f were formulated as follows.

Material	Example		
	2 TR1883	3 TR1853	4 TR1945
(80% active)Naalkylbenzenesulphonate	12	7	0
(80% active) alpha-olefin sulphonate	19	24	30
Citric Acid	8	4	0
Sodium Bicarbonate	10	5	0
Colourant	0.05	0.08	0.05
Sodium Sulphate	45.95	53.92	64.95
PerfumeF555.422	0	5	5
Mineral oil	1	0	0
Perfume F559.808	5	0	0

**[0096]** A 10 gram cylindrical block of diameter about 15 mm and length about 20 mm was left immersed in 2 litres of cold hard tap water on bench in a glass beaker (10 g), and the time for the block to dissolve was observed visually as follows:

TR1883~6 hours

TR1853~8 hours

TR1945~12-14 hours

**[0097]** A 10 gram cylindrical shape of diameter about 15 mm and length about 20 mm was housed into a central aperture formed in a typical formulation surfactant block given above in example 1 as reference B119. The finished block had a diameter of 45 mm and height 20 mm (as shown in FIG. 1 herein) and weighed 50 gm. The blocks were dropped into a UK style toilet cistern (UK91) which delivers a flush of 9 litres and was flushed according to a typical domestic use pattern of 17 flushes per day for a family of four, using hard water, measured as 250 ppm CaCO<sub>3</sub> at 10 to 12° C.

**[0098]** (It can be noted that for an in tank block varying the flush frequency will not ordinarily produce a pro rata change

in block life. For a lower flush frequency, the concentration of active ingredient in the flush water per flush will tend to be higher. The difference in lifetime of the two block parts will be similar.)

**[0099]** The life of the central block part was measured visually—i.e. when the central part had disappeared, giving the following results:

TR1883~1-1.5 days

TR1853~2-3 days

TR1945~12 days

**[0100]** Foam Heights in the Toilet Bowl:

B119/TR1883— gave a high foam between 3-4 cm every flush for 1 to 1.5 days, followed by a lower foam ~1.5 cm for the remainder of the block life

B119/TR1853— gave a similarly high foam between 3-4 cm every flush for 2 to 3 days, followed by a lower foam ~1.5 cm for the remainder of the block life

B119/TR1945— gave no significant initial improvement in foam height—giving typically ~1.5 cm foam throughout the block life.

A 50 gm. block of B119 used as a standard gave ~1.5 cm foam height through the block life

**[0101]** The following graph shows the results of measurement of colour intensity of the flush water, produced by the dissolved colourant in the block. The colour is initially boosted by the effect of the central core dissolving to release a higher amount of colourant over a shorter period. The colour release for the two component block, after the dissolution of the first component, is slightly lower and has a shorter life than the standard B119 50 gm block, due in part to the hollow central core and reduced quantity of the colourant in the remaining outer block. The % w/w of the colourant in the outer block part could be readily increased to provide more intense colouration for the remaining block life if required.

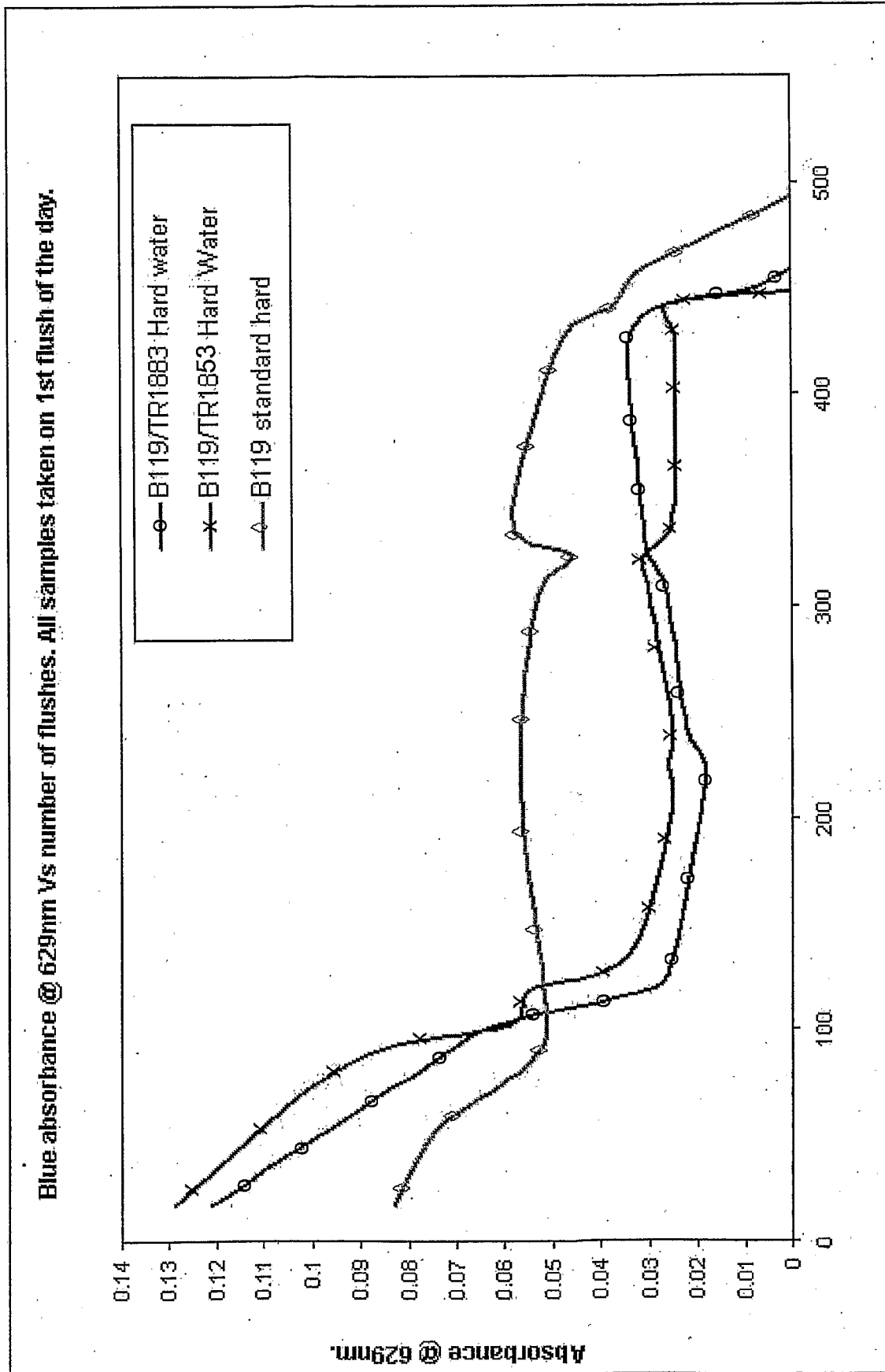

Fragrance performance was measured in fragrance booths containing blocks in standard UK cisterns and flushed as previously described. This typical high impact fragrance performance vs B119 standard was achieved throughout the life of the soluble core, as previously detailed

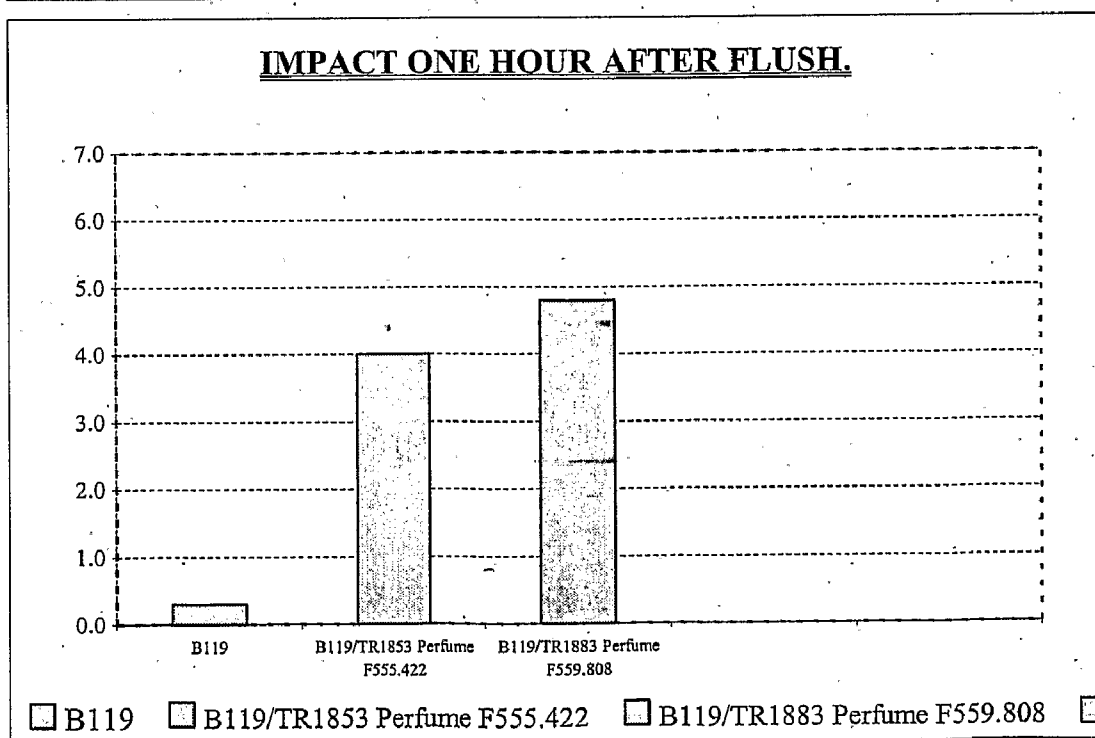
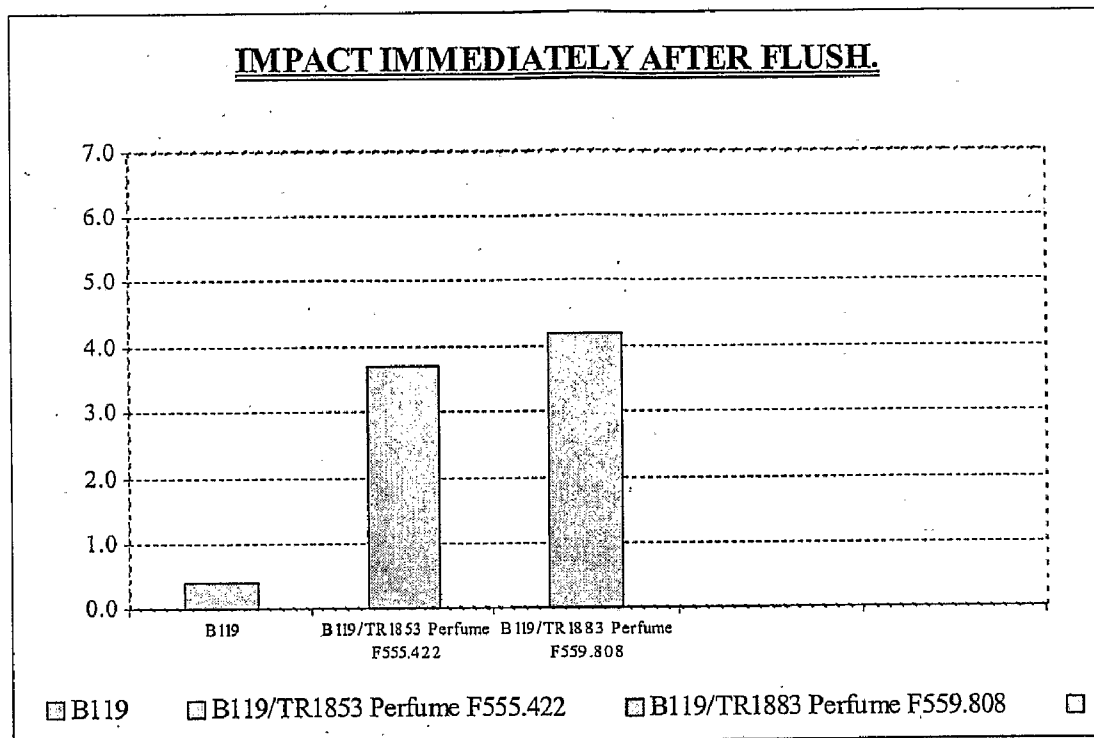

**[0102]** These graphs of the user perception of fragrance impact show the improved fragrance impact over a standard in cistern block product. In toilet testing the improved fragrance impact works whilst the inner block was still present.

## EXAMPLE 5

## Outer Formulation

**[0103]**

TB3987 (3-4 week life, colourant)	% w/w
(80% active) sodium alkylarylsulphonate	32
(92% active) secondary alkanesulphonate	10.7
Magnesium sulphate	10
Titanium Dioxide	1
Acid Blue 9	3.5
Sodium Sulphate	36.6
Pine Oil	6
OBPCP	0.2

**[0104]** In this example of an outer formulation, the titanium dioxide is added to provide a paler colour on-shelf and also reduces smearing of the dye during manufacture.

## EXAMPLE 6

**[0105]** A long life outer formulation was formulated as follows:

Formula B147	% w/w
(90% active) sodium alkylarylsulphonate	45
Calcium Sulphate	2
Magnesium Sulphate	7
Sodium Sulphate	10.8
Guar Gum	15
C9-C11 Primary Alcohol	8.5
Pine Oil	0.5
OBPCP	0.2
Acid Blue 9	11.0

**[0106]** In line with the previous examples, a 64 nm diameter 75 g block was prepared with 10 g inner core using formulation TR1853 (example 3) and a 65 g outer B147 as illustrated in FIG. 1, and compared with a single, similarly shaped block of formulation B147 weighing 75 g.

**[0107]** The combined block showed high foaming and fragrancing and colouring performance for the first 2 to 3 days until the core was completely dissolved, then steady colouring performance for about 14 weeks. In comparison, B147 on its own gave no fragrancing, low foam, and lower initial colouring, then steady colouring for about 16 weeks.

## EXAMPLE 7

**[0108]** A high foaming block with an overall life time in use of 3 to 4 weeks incorporated a limescale controller (a polyacrylate) and a colourant.

**[0109]** High Foaming Outer Formulation (DS225), weight 35 g

	% w/w
(81% active) Sodium alkylarylsulphonate	61.8
Acid Blue 9	4
Titanium Dioxide	1
Sodium Polyacrylate (Acusol* 445NG)	19
Pine Oil	11
OBPCP	0.2
Guar Gum	3

\*TM Rohm & Haas

**[0110]** High Foaming Inner Formulation (DS224), weight 5 g

	% w/w
(80% active) Sodium alpha-olefinsulphonate	79.45
92% secondary alkane sulphonate	10
Pigment	0.05
Pine Oil	9.5
C9-C11 Primary Alcohol	1

**[0111]** The formulations DS225 and DS 224 were co-extruded with DS 224 forming an inner core as seen in FIG. 1, with the inner core having a weight of about 5 g and the outer ring a weight of 35 g.

**[0112]** The example combination of DS225/DS224 delivered high foaming, colouring and limescale control for 4 weeks, with the inner core providing increased foaming for the first two weeks, until dissolved.

## EXAMPLE 8

**[0113]** The inner formulation DS 224 of example 7 was replaced with 8 g of formulation TR 1883 from example 2. This provided a block which gave high foaming, colouring and limescale control for about 3 weeks, with the inner core delivering a increased foam and initial fragrancing for the first 1.5 days until dissolved.

**[0114]** As noted above the formulation of the block parts is adapted to achieve the desired lifetime of the block parts. A greater % by weight of solubility control agent such as hydrophobes, fillers and salts leading to a longer lifetime, a greater amount of active ingredient such as colourant and surfactant leading to a greater perceived level of performance during the block lifetime.

**[0115]** In this specification we to measure the in-use life time of a block part in days, to the nearest half day for the faster dissolving part.

1. A lavatory cleansing block comprising at least two parts, the parts being formed from respective compositions, wherein, in use, at least one part dissolves substantially more rapidly than the or an other part or parts.

2. A block according to claim 1, wherein, in use, one part dissolves at least two times as fast as the other part(s).

3. A block according to claim 1, wherein, in use, the one part dissolves at least three time as fast as the other part(s).

4. A block according to claim 1, wherein, in use, the one part dissolves at least four times as fast as the other part(s).

5. A block according to claim 1, wherein the one part is dissolved substantially completely within one week.

6. A block according to claim 5, wherein the one part is dissolved substantially completely in less than three days.

7. A block according to claim 1, wherein the other part is dissolved substantially completely after three weeks.

8. A block according to claim 7, wherein, in use, the other part is dissolved substantially completely after four weeks.

9. A block according to claim 1, wherein the one part and the or an other part dissolve in use to provide a respective active component into the flush water of the toilet bowl, and the one part dissolves to provide an active component which is not provided by the other part.

10. A block according to claim 1, wherein the one part and the or an other part dissolve to provide a common active component into the flush water of the toilet bowl, and the concentration of active component provided by the one part in the toilet bowl is substantially higher than that provided by the other part.

11. A block according to claim 10, wherein the concentration of active component provided in the flush water by the one part is at least twice the concentration provided by the other part.

12. A block according to claim 11, wherein the concentration of active component provided in the flush water by the one part is at least four times the concentration of the other part.

13. A lavatory cleansing block comprising a body formed from a first composition; the body having at least one aperture therethrough which contains a core formed from a second composition, and wherein the first and second compositions dissolve at different rates in use.

14. A block according to claim 13, wherein the composition which dissolves more rapidly comprises a component which accelerates dissolution.

15. A block according to claim 14, wherein said composition comprises citric acid.

16. A block according to claim 14, wherein the said composition comprises sodium bicarbonate.

17. A block according to claim 13, wherein the composition which dissolves less rapidly comprises a solubility control agent which retards dissolution.

18. A block according to claim 17, wherein said composition comprises a hydrophobe.

19. A block according to claim 13, wherein, when the block is in use, the component made from the composition which dissolves more rapidly dissolves in less than one week.

20. A block according to claim 19, wherein said component dissolves in between one to three days.

21. A block according to claim 13, wherein, when the block is in use, the component made from the composition which dissolves less rapidly dissolves in one week or more.

22. A block according to claim 11, wherein the first composition dissolves in 3 weeks or more.

23. A block according to claim 13, wherein the second composition dissolves more rapidly than the first composition.

24. A block according to claim 13, wherein the core projects from at least one side of the block.

25. A block according to claim 13, wherein the core and the body have different colours.

26. A block according to claim 13, wherein the body is extruded.

27. A block according to claim 26, wherein the body and core are co-extruded.

28. Apparatus for making a lavatory cleansing block comprising means for forming a body formed from a first composition, the body having at least one aperture therethrough.

29. Apparatus according to claim 28, comprising means for forming a core formed from a second composition, the core being contained in the aperture.

30. Apparatus according to claim 28, wherein the body-forming means comprises an extruder.

31. Apparatus according to claim 30, wherein the body and core are formed by a co-extruder.

32. Apparatus according to claim 29, comprising means for shaping the core so that the core projects from the body.

33. Apparatus according to claim 32, wherein the means for shaping the core comprises a stamp for applying a force to one end of the core.

34. Apparatus according to claim 33, wherein the means for shaping the core comprises a mould for shaping the other end of the core.

35. Apparatus according to claim 33, comprising means for preventing the block from sticking to the stamp and/or mould.

36. Apparatus according to claim 35, comprising means for cooling the block.

37. Apparatus according to any of claim 35, comprising means for coating the block.

38. A lavatory cleansing block comprising a colourant and less than 5 percent by weight titanium dioxide.

39. A block as claimed in claim 38, wherein less than 2 percent and preferably less than about 1.5 percent by weight of titanium dioxide is provided.

40. A lavatory cleansing block comprising at least two parts, the parts being formed from respective compositions, wherein the in use lifetime of one part is at least twice as long as the in-use lifetime of the or another part.

41. A lavatory cleansing block as claimed in claim 40, wherein the in-use lifetime of the one part is at least three and preferably at least four times as long as the in-use lifetime of the or another part

42. A lavatory cleansing block as claimed in claim 40, wherein the in-use lifetime of the one part is at least seven times as long as the in-use lifetime of the or another part.

43. A lavatory cleansing block comprising at least two parts, the parts being formed from respective compositions, wherein the in use lifetime of one part is between 2 and 20 times as long as the in-use lifetime of the or another part.

44. A lavatory cleansing block as claimed in claim 43, wherein the in use lifetime of one part is between three and 15 times as long as the in-use lifetime of the or another part.

45. A lavatory cleansing block as claimed in claim 44, wherein the in use lifetime of one part is between four and 10 times as long as the in-use lifetime of the or another part.

46. A two part lavatory cleansing block having: in the first part: from 40 to 80% by weight, of the first part, of surfactant, 10 to 30% by weight of polyacrylate, and from 0 to 20% by weight of hydrophobe; of the other part: from 65 to 85% by weight, of the other part, of surfactant and from 0 to 20% by weight of hydrophobe.

47. A lavatory cleansing block as claimed in claim 46, wherein the surfactant is present in the first part in an amount of from 45 to 55% by weight.

48. A lavatory cleansing block as claimed in claim 47, wherein the surfactant is present in the second part in an amount of from 70 to 80% by weight.

49. A lavatory cleansing block as claimed in claim 46, wherein the hydrophobe is or includes pine oil.

**50.** A lavatory cleansing block as claimed in claim **46**, wherein the hydrophobe is or includes a primary alcohol and/or an ethoxylate.

**51.** A lavatory cleansing block as claimed in claim **46**, wherein the first part includes a colourant.

**52.** A lavatory cleansing block as claimed in claim **46**, wherein the first part has an in-use lifetime of at least three weeks.

**53.** A lavatory cleansing block as claimed in claim **52**, wherein the first part has an in-use lifetime of about four weeks.

**54.** A lavatory cleansing block as claimed in claim **46**, wherein the other part has an in-use lifetime of less than three weeks.

**55.** A lavatory cleansing block as claimed in claim **54**, wherein the other part has an in-use lifetime of about two weeks.

**56.** A two part lavatory cleansing block having: in the first part from 40 to 80% by weight of surfactant, from 10 to 30% by weight of polyacrylate, and 0 to 20% by weight of hydrophobe, and in the other part from 15 to 35% by weight, of the part, of surfactant, from 30 to 60% by weight of filler, and from 0 to 20% of a gassing agent.

**57.** A lavatory cleansing block as claimed in claim **56**, wherein the hydrophobe is or includes pine oil.

**58.** A lavatory cleansing block as claimed in claim **56**, wherein the hydrophobe is or includes a primary alcohol, and/or an ethoxylate.

**59.** A lavatory cleansing block as claimed in claim **56**, wherein the filler is a salt such as sodium sulphate.

**59.** A lavatory cleansing block as claimed in claim **56**, wherein the gassing agent includes a citrate, preferably citric acid, and/or a bicarbonate, preferably sodium bicarbonate.

**60.** A lavatory cleansing block as claimed in claim **56**, wherein the surfactant is present in the first part in an amount of from 45 to 55% by weight.

**61.** A lavatory cleansing block as claimed in claim **56**, wherein the surfactant is present in the second part in an amount of from 20 to 30% by weight.

**62.** A lavatory cleansing block as claimed in claim **56**, wherein the second part has an in-use lifetime of less than one week.

**63.** A lavatory cleansing block as claimed in claim **61**, wherein the second part has an in-use lifetime of less than four days.

**64.** A lavatory cleansing block as claimed in claim **56**, wherein the first part has an in-use lifetime of at least three weeks.

**65.** A lavatory cleansing block as claimed in claim **64**, wherein the second part has an in-use lifetime of about four weeks.

**66.** A lavatory cleansing block comprising first and second parts, the first part formed as an annulus and the second part substantially filling the centre of the annulus, wherein the composition of the second part includes at least 65% by weight, of the second part, of surface active agent and preferably 70 to 80%.

**67.** A lavatory cleansing block as claimed in claim **66**, wherein the second part includes a gassing agent.

**68.** A lavatory cleansing block as claimed in claim **46**, wherein the surfactant is an anionic surfactant.

**69.** A block according to claim **15**, wherein the said composition comprises sodium bicarbonate.

**70.** Apparatus according to claim **29**, wherein the body-forming means comprises an extruder.

**71.** Apparatus according to claim **34**, comprising means for preventing the block from sticking to the stamp and/or mould.

**72.** A lavatory cleansing block as claimed in claim **57**, wherein the hydrophobe is or includes a primary alcohol, and/or an ethoxylate.

**73.** A lavatory cleansing block as claimed in claim **57**, wherein the gassing agent includes a citrate, preferably citric acid, and/or a bicarbonate, preferably sodium bicarbonate.

**74.** A lavatory cleansing block as claimed in claim **58**, wherein the gassing agent includes a citrate, preferably citric acid, and/or a bicarbonate, preferably sodium bicarbonate.

\* \* \* \* \*