

(19) World Intellectual Property Organization  
International Bureau



(43) International Publication Date  
8 May 2003 (08.05.2003)

PCT

(10) International Publication Number  
WO 03/037420 A1

(51) International Patent Classification<sup>7</sup>: A61M 25/00, A61F 2/04

(21) International Application Number: PCT/US02/09355

(22) International Filing Date: 27 March 2002 (27.03.2002)

(25) Filing Language: English

(26) Publication Language: English

(30) Priority Data:  
09/981,634 16 October 2001 (16.10.2001) US

(71) Applicant: SCIMED LIFE SYSTEMS, INC. [US/US];  
One Scimed Place, Maple Grove, MN 55311-1566 (US).

(72) Inventors: BOTTCHEr, Benjamin, J.; 1048 Timberwale Lane, Kennesaw, GA 30152 (US). GRASSO, Michael; 3 Keane Court, Rye, NY 10580 (US).

(74) Agent: WILSON, Daniel, A.; Testa, Hurwitz & Thibault, LLP, High Street Tower, 125 High Street, Boston, MA 02110 (US).

(81) Designated States (national): AE, AG, AL, AM, AT, AU, AZ, BA, BB, BG, BR, BY, BZ, CA, CH, CN, CO, CR, CU, CZ, DE, DK, DM, DZ, EC, EE, ES, FI, GB, GD, GE, GH, GM, HR, HU, ID, IL, IN, IS, JP, KE, KG, KP, KR, KZ, LC, LK, LR, LS, LT, LU, LV, MA, MD, MG, MK, MN, MW, MX, MZ, NO, NZ, OM, PH, PL, PT, RO, RU, SD, SE, SG, SI, SK, SL, TJ, TM, TN, TR, TT, TZ, UA, UG, UZ, VN, YU, ZA, ZM, ZW.

(84) Designated States (regional): ARIPO patent (GH, GM, KE, LS, MW, MZ, SD, SL, SZ, TZ, UG, ZM, ZW), Eurasian patent (AM, AZ, BY, KG, KZ, MD, RU, TJ, TM), European patent (AT, BE, CH, CY, DE, DK, ES, FI, FR, GB, GR, IE, IT, LU, MC, NL, PT, SE, TR), OAPI patent (BF, BJ, CF, CG, CI, CM, GA, GN, GQ, GW, ML, MR, NE, SN, TD, TG).

Published:  
— with international search report

For two-letter codes and other abbreviations, refer to the "Guidance Notes on Codes and Abbreviations" appearing at the beginning of each regular issue of the PCT Gazette.

(54) Title: MEDICAL STENT WITH VARIABLE COIL AND RELATED METHODS

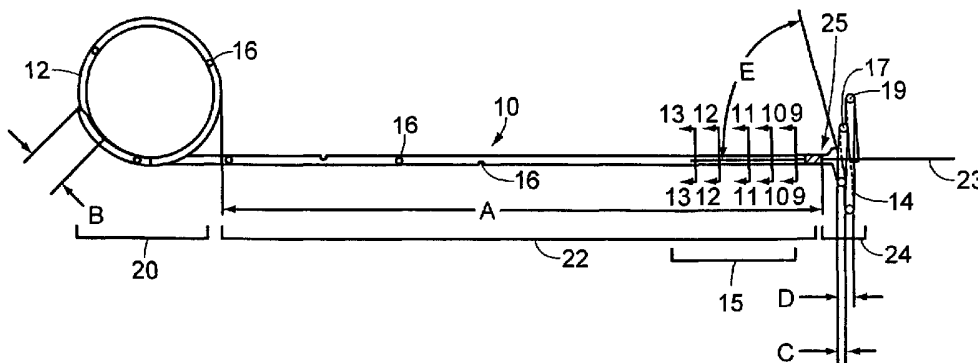

(57) Abstract: A medical stent includes a first section which includes a first material, defines a lumen, and includes a first coil completing more than one revolution. The first coil revolves about and is coaxial with an axis, expanding and opening as it revolves from the origin of the first coil. A second section of the stent includes a second material, defines a lumen, and includes a second coil completing at least one revolution. A third section defines a lumen and is located between the first and second sections. The third section includes a co-extrusion of the first and second materials. One of the first or second is harder than the other section.

WO 03/037420 A1

## MEDICAL STENT WITH VARIABLE COIL AND RELATED METHODS

### TECHNICAL FIELD

The present invention relates to medical stents and related methods. More specifically, the invention relates to medical stents having one section which is softer than a section at the other end of the stent.

5

### BACKGROUND INFORMATION

Fluid sometimes needs to be drained from a body. For example, urine formed in one or both kidneys might need to be drained into the bladder. One way to accomplish such drainage is to use a medical device that conveys the fluid (*e.g.*, urine) through a lumen. Such devices include stents and catheters. Existing stents can be uncomfortable for the patient, especially when they reside in the ureter between the kidney and the bladder, can be difficult for a medical professional to place in a patient, or can allow urine from the bladder to move into the ureter towards the kidney.

15

### SUMMARY OF THE INVENTION

The present invention provides medical stents for facilitating drainage of fluid and methods for placing such stents. For example, such stents can be placed in a ureter to facilitate drainage of fluid from a patient's kidney to a patient's bladder. Generally, stents according to the invention have a "softer" end and a "harder" end. The harder end generally resides in the patient's kidney while the softer end generally resides in the patient's bladder. The harder end can transition to the softer end in a transition section produced by, for example, a co-extrusion process where deposition of a first material is gradually ceased and deposition of a second is gradually increased. In general, the harder end is suited to retain the stent in the patient's kidney and/or facilitate placement in a patient, while the softer end is suited to increase patient comfort and/or retain the stent in the patient's bladder. Additionally, the softer end can inhibit movement of the stent in the bladder, minimize contact between the stent and the bladder, at least partially occlude the junction between the bladder and ureter in order to at least partially prevent retrograde urine flow from the bladder into the ureter both around the stent and through the stent, and/or otherwise minimize reflux of urine through the stent towards the kidney. Such stents also

25

are useful in other situations such as biliary drainage or, generally, where fluid is drained from one body structure to another body structure or out of the body.

In one embodiment, a medical stent can include a first section defining a lumen and including a first coil completing more than one revolution, a second section defining a lumen and including a second coil completing at least one revolution, and a third section defining a lumen and located between the first and second sections. The first section can include a first material having a first durometer value, and the second section can include a second material having a second durometer value. The second durometer value can be greater than the first durometer value, and at least a portion of the third section can include a co-extrusion of the first and second materials. The first coil can revolve about and be coaxial with an axis. A distance from a first point to the axis, the first point being at the center of a first cross-section of the first coil and on a line normal to the axis, can be less than a distance from a second point to the axis, the second point being at the center of a second cross-section of the first coil and on a line normal to the axis and the first point being closer to an origin of the first coil than the second point. The third section can be adjacent the origin of the first coil.

The embodiment described above, or those described below, can have any of the following features. The axis can generally extend along the third section. The second coil can be offset from the axis. The third section can include a shaft. The second coil can be generally perpendicular to the first coil. The first material can be ethylene vinyl acetate. The first material can have a durometer value of about 70 to about 90 on a Shore A scale. The second material can have a durometer value of about 80 to about 95 on a Shore A scale. A cross-section of the lumen in at least one of the first, second, and third sections can be circular. A cross-section of at least one of the first, second, and third sections can be circular. At least one of the first, second, and third section can include a radiopaque material. The second coil can have an outer diameter of at least about 2.0 cm. The first coil can be sized and/or shaped such that at least a portion of the first coil resides at the junction of a bladder and a ureter in a patient. The first coil can be a spiral.

In another aspect of the invention, a medical stent can include a first section defining a lumen and including a substantially planar first coil completing more than one revolution, a second section defining a lumen and comprising a second coil completing at least one revolution, and a third section defining a lumen and located between the first and second sections. The first section can include a first material having a first durometer value, and the second section can include a second material having a second durometer value. The second durometer value can be greater than the first durometer value. At least a portion of the third section can include a co-

extrusion of the first and second materials. The second coil can be generally perpendicular to the first coil.

In another aspect of the invention, a method for placing a medical stent includes inserting a medial stent, including any of the stents described above or below with any of the features  
5 described above or below, into a ureter. At least a portion of the first coil can reside at the junction of a bladder and a ureter in a patient. At least a portion of the first coil can at least partially occlude the junction.

### BRIEF DESCRIPTION OF THE DRAWINGS

10 In the drawings, like reference characters generally refer to the same parts throughout the different views. Also, the drawings are not necessarily to scale, emphasis instead generally being placed upon illustrating principles of the invention.

Figure 1 is a schematic rendering of a stent according to the invention.

Figure 2A is a schematic enlarged side view of one end of the stent of Figure 1.

15 Figure 2B is a schematic end-on view of the stent of Figure 1.

Figure 3 is a schematic cross section of the stent of Figure 1.

Figure 4 is a table showing examples of measurements of portions of the stent of Figure 1.

20 Figure 5 is a schematic rendering of an alternative embodiment of one coil of a stent according to the invention.

Figure 6 is a schematic end-on view of the coil of Figure 5.

Figure 7 is a schematic rendering of an alternate embodiment of a stent according to the invention having a similar coil to that in Figure 1 at one end and a different coil from that in Figure 1 at the opposite end.

25 Figure 8 is a schematic end-on view of the stent of Figure 7.

Figure 9 is an image of a cross section of the embodiment of Figure 1 taken along section line 9-9.

Figure 10 is an image of a cross section of the embodiment of Figure 1 taken along section line 10-10.

30 Figure 11 is an image of a cross section of the embodiment of Figure 1 taken along section line 11-11.

Figure 12 is an image of a cross section of the embodiment of Figure 1 taken along section line 12-12.

Figure 13 is an image of a cross section of the embodiment of Figure 1 taken along section line 13-13.

Figure 14 is a schematic rendering of an alternative embodiment of a stent according to the invention.

5 Figure 15 is a schematic top view of the embodiment of Figure 14.

Figure 16 is a schematic end-on view of the embodiment of Figure 14.

Figure 17 is a schematic enlarged end-on view of the embodiment of Figure 14.

Figure 18 is a schematic view of a proximal section of the embodiment of Figure 14.

10 Figure 19 is a schematic rendering of one system used to manufacture stents according to the invention.

Figure 20 is a table containing inner and outer diameter sizes for certain embodiments of the invention.

Figure 21 is a schematic rendering of the stent of Figure 1 in a kidney, ureter, and bladder.

15

## DESCRIPTION

The present invention provides medical stents for facilitating drainage of fluid and methods for placing such stents. For example, such stents are placed in a ureter to facilitate drainage of fluid from a patient's kidney to a patient's bladder. Generally, stents according to the invention have a "softer" end and a "harder" end. The harder end generally resides in the patient's kidney while the softer end generally resides in the patient's bladder. The harder end can transition to the softer end in a transition section produced by, for example, a co-extrusion process where deposition of a first material is gradually ceased and deposition of a second is gradually increased. As used herein, the terms "hard" and "soft," and various grammatical forms thereof, are general terms meant generally to refer to a difference in properties, including, but not limited to, (1) a difference in the durometer value of all or some of the material(s) used to construct a stent (for example, a higher durometer value of one material used in constructing a section of a stent, even if one or more other materials are also used to construct that same section of stent, can mean "hard" and a lower durometer value of one material used in constructing another section of a stent, even if one or more other materials are also used to construct that same section of stent, can mean "soft"), (2) a difference in the retention strengths of the coils on either end of a stent (for example, a higher retention strength can mean "hard" and a lower retention strength can mean "soft"), (3) a difference in stiffness (for example, a more stiff material/section of stent can be "hard" and a less stiff material/section of stent can be "soft"), or other differences

20  
25  
30

between material(s) used to construct a stent or between sections of a stent that those skilled in the art would consider "hard" and/or "soft."

Ureteral stents can be made from a higher durometer material to facilitate placement and retention in the body. However, these firmer stents may contribute to some patient discomfort  
5 issues. Ureteral stents also can be made from a lower durometer material in an effort to enhance patient comfort. However, these softer stents may be difficult to place and may migrate once placed in the patient's body.

Stents according to the invention are harder end at one end and softer at the other end. This construction is desirable because, in general, the harder end is suited for placing the stent in  
10 the patient's kidney and/or to retain the stent in the patient's kidney, while the softer end is suited to increase patient comfort and/or, to a degree, retain the stent in the patient's bladder. Moreover, stents according to the invention can have a coil at the end of the stent to reside in the kidney that is of a size and/or shape that enhances retention of the stent in the kidney. Also, stents according to the invention can have a coil at the end of the stent to reside in the bladder  
15 that inhibits motion of the stent within the bladder, that enhances patient comfort by reducing, for example, contact between the stent and the neck of the bladder and/or the floor of the bladder, that at least partially occludes the junction between the bladder and ureter to at least partially prevent urine from entering the ureter from the bladder either through or around the stent, and/or that otherwise minimizes reflux of urine through the stent towards the kidney.  
20 Accordingly, stents according to the invention are designed to incorporate multiple desirable features into a single stent and can include any combination of these features.

Referring to Figures 1, 2A, and 2B, a schematic representation of one embodiment of a stent 10 according to the invention is shown. Generally, the stent 10 has three sections 20, 22,  
25 24. A first section 24 is located at the proximal end (as used herein, proximal refers to the end of a stent closest a medical professional when placing a stent in a patient) of the stent 10. A second section 20 is located at the distal end (as used herein, distal refers to the end of a stent furthest from a medical professional when placing a stent in a patient) of the stent 10. A third section 22 is located between the first 24 and second sections 20 and is generally in the form of a shaft. The location of the sections 20, 22, 24 as shown in Figure 1 is approximate, emphasis instead being  
30 placed on illustrating the principles of the invention.

The first section 24 has a first coil 14 that makes more than one revolution. The first coil 14 revolves about an axis 23 and is coaxial with the axis 23. The axis 23 is shown extending generally along the third section 22 of the stent 10. Although stents according to the invention typically are flexible, the stents can be placed in a position in which the shaft of the stent is

generally linear to form an axis. In this embodiment, the first coil 14 makes more than two revolutions about the axis 23. However, alternate embodiments can revolve to a greater or lesser extent about the axis 23 (for example, less than approximately two revolutions or more than approximately two revolutions). The first coil 14 begins at an origin 25. Typically, the origin of stents according to the invention is the location on the stent where the generally straight shaft connects to the coil. However, the origin can be slightly away from this location in certain embodiments. The first section 24 and third section 22 meet at the origin 25 in this embodiment. As the first coil 14 revolves about the axis 23, it opens outwardly. Thus, a point 17 that is located at the center of a cross-section of the first coil 14 closer to the origin 25 and along a line 17a normal to the axis 23 is closer to the axis 23 than is a second point 19 that is located at the center of a second cross-section of the first coil 14 further from the origin 25 and along a line 19a normal to the axis 23 (best seen in Figure 2A). The following measurements provide one, non-limiting example of the possible size of the first coil 14. One revolution of the first coil 14 has a width C of about 0.1 cm, and two revolutions have a width D of about 0.2 cm. One of the turns of the coil 14 is measured to be at an angle E of about 75 degrees from the axis 23. A height F of one part of the coil 14 is about 0.75 cm, and at a location one revolution from measurement F, a height G of the coil 14 is about 1.5 cm.

The second section 20 has a second coil 12 which also makes more than one revolution and also is offset from the axis 23 of the first coil 14 and the general axis of the stent 10. The second coil 12 has a tapered tip. Typically, a second coil is larger than coils in some other stents. For example, a coil can have a diameter of greater than about 1.5 cm, preferably greater than about 1.9 cm (including a diameter of about 2.0 cm), and more preferably greater than about 2.4 cm (including a diameter of about 2.5 cm). This size can enhance retention of a stent in a patient's kidney.

Holes 16 (only some of the holes are labeled) in the outer surface of the stent 10 are located along the length of stent 10. These holes 16 allow the outside environment to communicate with a lumen inside the stent 10. The lumen 50 and the stent's outer diameter 52 can be shaped in cross-section as a circle (best seen in Figure 3) or any other appropriate shape such as an oval or other oblong shape. The holes 16 can be placed in many configurations, one of which is shown in Figure 1. In this configuration, the holes 16 are present in the first coil 14 in about its first revolution and not in about its second revolution. These holes 16 are approximately evenly spaced apart in the first coil 14 and are located along the length of the shaft at intervals of about 1.5 cm with one rotated 90 degrees from the next. In 4.8 French stents, about two to about four holes 16 are in the second coil 12 and in 6, 7, or 8 French stents, about

three to about five holes 16 are on the second coil 12. These holes can be evenly spaced. A suture may be attached to the first section 24 for placing the stent 10 in a desired position as well as removing the stent 10. Figure 4 provides non-limiting examples of sizes of various stents according to the invention. For example, a 4.8 French stent can have a length along portion A of the stent 10 of about 24, 26, or 28 mm and a length along portion B (the area in which the tip of the stent 10 tapers) of the stent 10 of about 4 mm and can have holes of about 0.26 inches.

The third section 22 is formed from a coextrusion of the material(s) from which the first section 24 is made and the material(s) from which the second section 20 is made. As shown in Figure 1, a transition section 15 (i.e., where the material(s) making up one portion of the stent transition to the material(s) making up another portion of the stent) in the third section 22 is closer to the first coil 14 than to the second coil 12. However, in alternative embodiments, the transition section can be located anywhere along the length of the stent. The transition section typically is located between the coils on either end of the stent and is about 2 cm long to about 10 cm long. However, the transition section can be any length. The first section 24 includes a first material having a first durometer. The second section 20 includes a second material having a second durometer, which is greater than the first durometer value. Accordingly, the first section is "softer" than the second section. The transition section 15 includes both the first and second materials, and the first and second materials are separate, distinct, and associated in an unsymmetrical, irregular configuration. In operation, the first coil 14 typically resides in the patient's bladder, and the second coil 12 typically resides in the patient's kidney (Figure 21).

An alternative embodiment of a first coil 114 to be placed in a patient's bladder is shown in Figures 5 and 6. The first coil 114 in this embodiment is in a generally spiral or funnel shape that expands as it revolves about an axis 123 from the origin 125 of the first coil 114. Again, a point 117 that is located at the center of a cross-section of the first coil 114 closer to the origin 125 and along a line normal to the axis 123 is closer to the axis 123 than is a second point 119 that is located at the center of a second cross-section of the first coil 114 further from the origin 125 and along a line normal to the axis 123. The first coil 114 in this embodiment makes more than three revolutions about the axis 123. The following measurements provide one, non-limiting example of the possible size of the coil 114. One revolution of the first coil 114 has a width H of about 0.33 cm, and three revolutions have a width I of about 0.99 cm. The turns of the coil 114 spread outward at an angle J of about 31 degrees relative to the axis 123. A height K of one part of the coil 114 is about 0.5 cm, and another height L of the coil 114 is about 1.5 cm.

In a further alternative embodiment of a first coil 314 to be placed in a patient's bladder, a stent 310 is shown in Figures 7 and 8 that is substantially similar to that shown in Figure 1



except for the first coil 314. The first coil 314 has a generally spiral or funnel shape that expands as it revolves about an axis 323 from the origin 325 of the first coil 314. As above, a point 317 that is located at the center of a cross-section of the first coil 314 closer to the origin 325 and along a line normal to the axis 323 is closer to the axis 323 than is a second point 319 that is  
5 located at the center of a second cross-section of the first coil 314 further from the origin 325 and along a line normal to the axis 323. The first coil 314 makes more than two revolutions about the axis 323, and the second coil 312 is generally perpendicular to the first coil 314. The following measurements provide one, non-limiting example of the possible size of the coil. One of the turns of the first coil 314 is measured to be an angle P of about 37 degrees from the axis  
10 323. One revolution of the first coil 314 has a width Q of about 0.5 cm, and two revolutions have a width R of about 1 cm.

The stent 10 of Figures 1, 2A, and 2B is a single piece and is sized to fit within a ureter. For example, two types of ethylene vinyl acetate ("EVA") can be extruded to form the stent. In a continuous process, the first section 24 is formed from one type of EVA; the third section 22,  
15 then, is formed by gradually ceasing the deposition of the first type of EVA and gradually increasing the deposition of a second type of EVA (creating the transition section 15 in the third section 22); and the other end of the stent, the second section 20, is formed from the second type of EVA after the first type of EVA has ceased being extruded. Each type of EVA has a different durometer value, with the first type of EVA having a durometer value that is less than the  
20 durometer value of the second type of EVA. The two materials in the third section 22 are separate, are distinct, and are associated with each other in an irregular configuration. Additionally, other materials may be mixed with the first and/or second types of the EVA prior to extrusion. For example, radiopaque materials, such as bismuth subcarbonate, and/or colorants can be added. The addition can occur at the site of manufacture or a supplier can supply the  
25 EVA already compounded with the radiopaque material alone or with the colorant alone or with both the radiopaque material and the colorant. Even if these materials are mixed, the fact that one EVA type has a durometer value less than the second EVA type can mean that the section of the stent formed from the first type of EVA is "softer" than the section of the stent formed from the second type of EVA.

30 After extrusion, the curled portions are formed. For example, the extrusion can be placed on a mandrel, shaped in a particular form, and the extrusion can be formed into a desired shape by heating the extrusion while on the mandrel. Alternatively, the extrusion can be laid into a plate having a groove cut into it in the shape of the desired final product. The plate is heated from below (for example, with a heat lamp) to form the extrusion into a shape according to the

configuration of the groove. Both coils can be formed at the same time using two adjacent plates, each with a groove for the coil at either end of the stent. The plates are heated at different temperatures, to the extent necessary, for example, if the two ends of the stent are made from different material(s), and can be heated for the same length of time. Additionally, after  
5 extrusion, holes can be bored into the stent by placing a nylon core inside the stent to prevent the stent from collapsing and drilling through the stent, for example, with a hollow sharpened bit.

Figures 9-13 show a series of cross-sectional views taken along the length of the stent 10. The approximate position of these cross-sections are shown in Figure 1. It should be understood that the position of these cross-sections is merely an example. In various embodiments, the transition section of the medical stent can be relatively short, or relatively long, depending upon the physical characteristics of the stent that are desired. Additionally, sections taken in various  
10 embodiments may look different than the representations shown in Figures 9-13, depending upon, for example, the length of the transition section, the materials being extruded, and the method of co-extrusion used to manufacture the stent. Thus, the cross-sections shown in Figure  
15 1 and Figures 9-13 should be understood to illustrate both one embodiment of the invention and the general principle whereby the material(s) forming one section of the stent transition to the material(s) forming the other section of the stent. These figures show one material mixed with a colorant (for example, EVA and a colorant) (the darker portions of the cross-section) gradually increasing in abundance along the length of at least part of the stent and a second material not  
20 mixed with a colorant (for example, a second type of EVA) (the lighter portions of the cross-section) gradually decreasing in abundance along the length of at least part of the stent. Some of these views are indicative of the first and second materials being separate, distinct, and associating in an unsymmetrical, irregular configuration. In certain embodiments, the change in material composition can occur over any part of the shaft of the stent or all of the shaft of the  
25 stent. At least one of the materials can be ethylene vinyl acetate. Additionally, stents according to the invention can have several transition zones where materials change and/or can have more than two materials (or more than two mixtures of materials) that change along the length of the stent. For example, the shaft of a stent, or a portion thereof, may or may not be the same material(s) and/or the same durometer as either of the two coils. Moreover, each of the shaft and  
30 two coils can be formed from different material(s).

In certain embodiments, the material(s) that make up the second section of the stent (the harder section of the stent) can extend at least half way down the shaft of the stent, and can extend even further, such that the transition section is closer to the first coil (the coil in the softer section of the stent) than to the second coil (the coil in the harder section of the stent). Such a

configuration enhances the placement characteristics of a stent because the preponderance of hard material(s) makes the stent stiffer and easier for a medical profession to place. In many embodiments, the transition of material(s) does not occur in one of the coils such that each coil is formed from a single material (or a single mixture of materials). However, the transition can occur anywhere along the length of the stent. Also in some embodiments, the inner diameter of the stent is maximized but not so much as to adversely impact the stent's ability to be pushed over a guidewire.

In an alternative embodiment, and referring to Figures 14, 15, 16, 17, and 18, a stent 210 is shown having a first section 224 located at the proximal end of the stent 210. A second section 220 is located at the distal end of the stent 210. A third section 222 is located between the first 224 and second sections 220 and is generally in the form of a shaft. The location of the sections 220, 222, 224 as shown in Figures 14 and 18 is approximate, emphasis instead being placed on illustrating the principles of the invention.

The first section 224 has a first coil 214 that makes more than one revolution. The first coil 214 revolves about an axis 223 and is coaxial with the axis 223. The axis 223 is shown extending generally along the third section 222 of the stent 210. Although stents according to the invention typically are flexible, the stents can be placed in a position in which the shaft of the stent is generally linear to form an axis. In this embodiment, the first coil 214 makes more than two revolutions about the axis 223. However, alternate embodiments can revolve to a greater or lesser extent about the axis 223 (for example, less than approximately two revolutions or more than approximately two revolutions). The first coil 214 is attached to the shaft of the stent 210 at a neck 211. The neck is slightly curved and is set back from the axis 223. As the first coil 214 revolves about the axis 223, it revolves outwardly and substantially in a single plane. Accordingly, the first coil 214 is substantially planar. The following measurements provide one, non-limiting example of the possible size of the first coil 214 and the neck 211. The neck 211 has a length M of about 0.82 cm, and the greatest height N of the coil 214 is about 1.5 cm.

The second section 220 has a second coil 212 which also makes more than one revolution and also is offset from the axis 223 of the first coil 214 and the general axis of the stent 210. The second coil 212 is generally perpendicular to the first coil 214 and has a tapered tip. Typically, a second coil is larger than coils in some other stents. For example, a coil can have a diameter of greater than about 1.5 cm, preferably greater than about 1.9 cm (including a diameter of about 2.0 cm), and more preferably greater than about 2.4 cm (including a diameter of about 2.5 cm). In this example the second coil has a diameter of about 2.5 cm. This size can enhance retention of a stent in a patient's kidney.

Holes 216 in the outer surface of the stent 210 allow the outside environment to communicate with a lumen inside the stent 210. The holes 216 can be placed in many configurations. Holes 216 are shown in the first coil 214 in about its first revolution and are approximately evenly spaced apart. Holes also can be located in other parts of the stent 210.

5 The lumen and the stent's outer diameter can be shaped in cross-section as a circle or any other appropriate shape such as an oval or other oblong shape. A suture may be attached to the first section 224 for placing the stent 210 in a desired position as well as removing the stent 210.

The third section 222 is formed from a coextrusion of the material(s) from which the first section 224 is made and the material(s) from which the second section 220 is made. A transition section 215 (i.e., where the material(s) making up one portion of the stent transition to the material(s) making up another portion of the stent) in the third section 222 is closer to the first coil 214 than to the second coil 212. However, in alternative embodiments, the transition section can be located anywhere along the length of the stent. The transition section typically is located between the coils on either end of the stent and is about 2 cm long to about 10 cm long.

15 However, the transition section can be any length. The first section 224 includes a first material having a first durometer. The second section 220 includes a second material having a second durometer, which is greater than the first durometer value. Accordingly, the first section is "softer" than the second section. The transition section 215 includes both the first and second materials, and the first and second materials are separate, distinct, and associated in an unsymmetrical, irregular configuration.

20 Interrupted layer extrusion techniques, gradient-type coextrusion techniques, or similar techniques can be used to produce any of the transition sections described above. Such extrusion techniques can be used instead of using joints or welds to bring together two ends of a stent, each end having a different physical property than the other end. Such joints or welds can fail during use of the stent and can be difficult to manufacture. Continuous material extrusion according to the invention enhances stent integrity while allowing for desired placement and drainage characteristics. Additionally, continuous extrusion products tend not to kink in the transition zone as might a stent with a butt-joint or a weld. In general, any type of thermoplastic polymer can be extruded such as a silicone, a polyurethane, or a polyolefin copolymer such as EVA. In general, in one embodiment of the invention, two types of EVA (at least one type of EVA can be mixed with a radiopaque material and at least one type of EVA can be mixed with a colorant) are extruded to form the stent. In a continuous process, one end of the stent is formed from one type of EVA (for example, the first section 24 in Figure 1); an intermediate section (for example, the third section 22 in Figure 1) containing a transition section (for example, the transition section 15

in Figure 1), then, is formed by gradually ceasing the deposition of the first type of EVA and gradually increasing the deposition of a second type of EVA; and the other end of the stent is formed from the second type of EVA (for example, the second section 20 in Figure 1) after the first type of EVA has ceased being extruded. Each type of EVA has a different durometer value.

5 The mixing of the two types of EVA in the transition section produces a section in which the two materials are separate, are distinct, and are associated with each other in an irregular configuration. After extrusion, the curled portions are formed.

In more detail and in one example of an extrusion technique as shown in Figure 19, a gradient-type technique, a first pelletized type of EVA is placed in a first dryer 50 and a second  
10 pelletized type of EVA is placed in a second dryer 60. The dryers 50, 60 are hoppers to contain the pellets, and, to the extent necessary, to dry the pellets, and each dryer 50, 60 feeds the pellets to an extruder 52, 62. The two extruders 52, 62 melt the pellets, and each of the melted materials passes through a separate adapter 54, 64 to a separate melt pump 56, 66 (which are also referred to as a gear pumps). Each melt pump 56, 66 has a rotary gear which allows the melted materials  
15 to pass through the pump 56, 66. A computer 58 runs two servo motors 55, 65 that control the melt pumps 56, 66. The computer 58 controls the revolutions per minute as a function of the distance over which a point in the extruded product travels. There is a feedback loop between each melt pump 56, 66 and its related extruder 52, 62 such that when the pressure between the extruder 52, 62 and the melt pump 56, 66 is too high, the extruder 52, 62 shuts off. Each  
20 extruder 52, 62 is a slave to its respective melt pump 56, 66. The two separate lines, each containing a different EVA, come together at a cross-head 68. The cross-head 68 contains lumens that are separate from each other except for a relatively short distance in the cross-head 68. This distance is immediately adjacent a die and a tip where the extruded product exits the cross-head 68. The two materials only come together immediately adjacent to the die and the tip.  
25 The die dictates the outer diameter of the extruded product and the tip dictates the inner diameter of the product. The end of the tip is flush with the end of the die. Air is metered into a port that connects with the tip. Air from the tip pushes out the outer and inner diameters of the extruded product. Also, the tip is ported to the atmosphere to avoid the extruded product being flat. The extruded product (emerging from the cross-head 68 according to arrow 70) is then cooled in a  
30 quench tank 72, which is a water bath, to fix the product's shape. Next, the cooled product is dried with an air blower 74 and is measured with a laser micrometer 76. The laser micrometer 76 measures the outer diameter of the extruded product, and other gauges can be used to measure the inner diameter of the extruded product. The laser micrometer 76 is either monitored by an operator or is connected in a feedback control loop to control the final diameter of the extruded

product. After passing through the laser micrometer 76, the extruded product is pulled through a "puller/cutter" machine 78. This device 78 pulls at a particular rate to control the shape of the extruded product, such as tapers on the ends of the extruded product, and cuts the extruded product to the correct length for a stent. Finally, a conveyer 80 separates the acceptable and unacceptable final products. Generally, if the diameter of the extruded product is too large according to the laser micrometer, the operator or the feedback loop will act to speed up the puller/cutter, decrease the extruder(s)/melt pump(s) output(s), and/or decrease the internal air support provided through the tip. If the diameter of the extruded product is too small, the operator or the feedback loop will act to slow down the puller/cutter, increase the extruder(s)/melt pump(s) output(s), and/or increase the internal air support provided through the tip. When the adjustments are made, the measurement of the inside diameter of the extruded product can be taken into account.

This system has at least three features. First, the entire system has no valves, and, specifically, the cross-head 68 has no moving parts such as valves. Second, extrusion can occur in a non-linear fashion, because the computer 58 and servo motors 55, 65 control the melt pumps 56, 66 on the basis of distance traveled. Thus, the melt pumps 56, 66 are "ramped up" or "ramped down" as necessary. Accordingly, a theoretically infinite gradient of material can be extruded by varying the pumping rates of the melt pumps 56, 66. And third, the process for combining the two EVA materials does not involve production of waste melted material as a byproduct of manufacture.

Through this machinery, in a continuous process, one end of the stent is formed from one type of EVA; an intermediate section containing a transition section, then, is formed by gradually ceasing the deposition of the first type of EVA and gradually increasing the deposition of a second type of EVA; and the other end of the stent is formed from the second type of EVA after the first type of EVA has ceased being extruded. Each type of EVA has a different durometer value. A radiopaque material and/or a colorant can be added to either of the EVA materials (the addition can occur at the site of manufacture or a supplier can supply the EVA already compounded with the radiopaque material, such as bismuth subcarbonate, alone or with the colorant alone or with both the radiopaque material and the colorant). The mixing of the two types of EVA in the transition section results in a section in which the two materials are separate, are distinct, and are associated with each other in an irregular configuration. After extrusion, the curled portions are formed. For example, the extrusion can be placed on a mandrel, shaped in a particular form, and the extrusion can be formed into a desired shape by heating the extrusion while on the mandrel. Alternatively, the extrusion can be laid into a plate having a groove cut

into it in the shape of the desired final product. The plate is heated from below (for example, with a heat lamp) to form the extrusion into a shape according to the configuration of the groove. Both coils can be formed at the same time using two adjacent plates, each with a groove for the coil at either end of the stent. The plates are heated at different temperatures, to the extent  
5 necessary, for example, if the two ends of the stent are made from different material(s), and can be heated for the same length of time. Additionally, after extrusion, holes can be bored into the stent by placing a nylon core inside the stent to prevent the stent from collapsing and drilling through the stent, for example, with a hollow sharpened bit. The stent also can be covered in its entirety with a lubricant. Useful coatings include those that are hydrophilic.

10 Various embodiments of medical stents according to the invention can have any of a variety of features. A dual durometer stent that incorporates a higher durometer value material (for example, firm EVA) for the renal coil and that gradually transitions into a lower durometer value material (for example, soft EVA) for the bladder coil is useful. For example, the "hard" material can be EVA having a durometer value of about 80 to about 95 on a Shore A scale,  
15 preferably about 87 to about 95 on a Shore A scale, and more preferably about 90 on a Shore A scale, and the "soft" material can be another type of EVA having a durometer value of about 70 to about 90 on a Shore A scale, preferably about 78 to about 90 on a Shore A scale, and more preferably about 86 on a Shore A scale. These values are examples of a more general principle, namely, having a stent with a harder end and a softer end. Other materials or EVA having a  
20 durometer value different than that described above can be useful. In some embodiments, the materials forming the stent, such as the two types of EVA, are mixed with other materials. For example, as described above, each type of EVA can be mixed with a radiopaque material, such as bismuth subcarbonate, or a colorant. The radiopaque material allows a medical professional to place the stent under the guidance of an x-ray device and fluoroscope or other similar device  
25 where the radiopaque material appears on a view screen because it blocks or reflects x-ray energy. The colorant also can be used as a visual cue to a medical professional about the location of the stent in the patient.

Another way to describe the two ends of the stent are by the coil retention strength of each coil of the stent. For example, such retention strengths can be used as a measure of the  
30 ability to resist migration within a patient, or, more broadly, as a measure of how "hard" or how "soft" the ends of the stent are. One way to determine retention strength is found in American Society for Testing and Materials (ASTM) Designation F 1828-97: Standard Specification for Ureteral Stents, approved November 10, 1997, and published May, 1998, the disclosure of which is incorporated herein by reference. This specification covers single-use ureteral stents with

retaining means at both ends, during short term use for drainage of urine from the kidney to the bladder. These stents typically have diameters of 3.7 French to 14.0 French, lengths of 8 cm to 30 cm, and are made of silicone, polyurethane, and other polymers. They are provided non-sterile for sterilization and sterile for single-use. It is noted that this ASTM standard excludes long-term, indwelling usage (over thirty days), use of ureteral stents for non-ureteral applications, and non-sterile stents. Nevertheless, even if stents according to the invention meet any of these exclusions, or do not otherwise fall under the scope of this ASTM standard, to the extent those skilled in the art understand it to be reasonable to use the coil retention strength test method described in this document, the test method can be used.

10 The retention strength test method (section 6.2 of the ASTM document) involves using a funnel block submerged in a water bath at approximately 37 degrees Celsius. The funnel block is a block of TEFLON or DERLIN defining a funnel. The funnel is two inches at its widest diameter and, in cross section, has walls that form an approximately 60 degree angle. The funnel narrows to a bore slightly larger than the specimen to be tested, and this bore is about 0.675 inches long. There must be clearance between the outside diameter of the test specimen and the inside diameter of the hole in the funnel block through which the specimen is pulled. For example, for stents of 3.7 to 8.5 French, a funnel bore should be 0.125 inches (3.16 mm) in diameter; for stents of 10.0 French, a funnel bore should be 0.159 inches (4.04 mm) in diameter; and for stent of 14.0 French, a funnel bore should be 0.210 inches (5.33 mm) in diameter. The test specimen is removed from its sterile packaging, and the retention means (for example, a coil at the end of the stent) of the specimen is straightened with an appropriate guidewire. The test specimen is soaked for at least thirty days and is cut to allow a straight portion of the stent to be inserted upwards through the funnel fixture into the grip of a tensile test machine without loading the retention mechanism of the stent to be tested. Prior to inserting the test specimen, the test specimen is submerged in the water bath for at least one minute to allow it to reach thermal equilibrium. If the material is significantly effected by moisture, the test specimen should be allowed to equilibrate for a minimum of 24 hours. The straight portion of the stent then is inserted through the bottom of the funnel and into the grip. If testing 30 days after opening the package, the retention means is not straightened prior to testing. Then, the specimen is pulled up through the funnel at 20 inches/minute. The maximum force required to pull the stent completely through the funnel is recorded.

In certain embodiments, the bladder coil (for example, but without limitation, the first coil 14 in Figure 1) retention strength is less than or equal to the renal coil retention strength (for example, but without limitation, the second coil 12 in Figure 1). In other embodiments, the



kidney coil retention strength is less than or equal to the bladder coil retention strength.

Typically, retention strengths of the two coils are chosen such that the retention strength of the coil placed in the kidney is greater than the retention strength of the coil placed in the bladder. A retention strength of at least 10 gram-force or more is desirable in many embodiments.

5           Some embodiments of stents according to the invention can have an outer diameter from about four to about nine French with lengths of from about ten to about thirty centimeters as measured between the coils. Figure 20 shows an example of some suitable French sizes along with the size of the inner and outer diameters. Unless otherwise noted, the dimensions in Figure 20 are in inches. The notation "O.D." refers to outer diameter and the notation "I.D." refers to  
10 inner diameter. In certain embodiments, stents with standard outer diameter sizes can have inner diameters (i.e., the diameter of a lumen) that are larger than standard inner diameters normally present in those standard outer diameters. This configuration facilitates passage of the stent over the guidewire and increases the drainage allowed by the stent. For example, a four French stent can have an inner diameter equivalent to that found in a 4.8 French stent to increase drainage and  
15 to facilitate a 0.35 inch and/or a 0.38 inch guidewire, and/or a five French stent can have an inner diameter equivalent to a six French stent to facilitate a 0.35 inch and/or a 0.38 inch guidewire and increase drainage. The stent can have graduation marks and stent size imprinted on stent.

The operation of stents according to the invention are described in Figure 21. It should be understood that although one embodiment of stents according to the invention is described,  
20 other embodiments can operate in a similar fashion. In operation of one embodiment of a stent 10, the distal end of the stent 10 is inserted through the bladder 104 and ureter 102 into the kidney 100. For example, a medical professional inserts a guidewire (not shown) through the bladder 104, ureter 102 and kidney 100 of a patient. The stent 10 is placed over the guidewire, thereby uncurling the coils 12, 14 to the straightened position. The stent 10 slides along the  
25 guidewire, and the guidewire is sufficiently stiff to hold the coils 12, 14 in a straight configuration while the guidewire is in the lumen of the stent 10. A pusher (optionally with a radiopaque band) that slides over the guidewire, behind the stent 10, abuts the end of the stent and is used to push the stent 10 over the guidewire. The radiopaque band, if used, allows a medical professional to view the pusher on a fluoroscope, particularly where it abuts the stent,  
30 using x-rays. Additionally, if the stent 10 is radiopaque, placement of the stent in the patient can be confirmed by viewing the stent on a fluoroscope. Once at least a portion of the second section 20 is positioned within the kidney 100, the guidewire is withdrawn. If a pusher is used, the pusher holds the stent in place while the guidewire is removed. The shape-memory material from which second coil 12 is constructed allows the second section 20 in a straightened position

to return to its coiled shape in the kidney 100 once the guidewire is withdrawn. A similar re-coiling of the first coil 14 also occurs in the bladder 104 when the guidewire is withdrawn from that area of the stent 10. Thus, the "hard" coil 12 is placed in the kidney 100, and the "soft" coil 14 is placed in the bladder 104. Stents can be provided as a kit with a guidewire and/or a pusher.

5           Additionally, the size and/or shape of the first coil 14 allow the stent 10 to at least partially occlude the junction 106 between the bladder 104 and the ureter 102 (at the orifice of the ureter at the base of the trigone), for example, because the first coil 14 tends to plug the ureter. This occlusion may at least partially prevent urine from passing around or through the stent 10 from the bladder 104 into the ureter 102. Additionally, the size and/or shape of the first  
10 coil 14 may at least partially prevent the stent 10 from touching the neck of the bladder 104 and/or the floor of the bladder 104, and, thus, may at least partially prevent the stent 10 from irritating or "tickling" the bladder 104. Also, the shape and/or size of the first coil 14 can inhibit motion of the stent within the bladder, minimizing contact with the bladder neck and bladder floor. Such minimization can reduce the frequency of contractions of the bladder, increasing  
15 comfort. Also, having a minimum number of holes in the first coil 14 reduces the number of locations that pressure, created when a patient urinates, can force urine back into the stent. Other forms of a first coil are useful to the extent they can perform any of the functions described above. For example, those embodiments shown in Figures 5-6, 7-8, and 14-18 can perform such functions. Additionally, the relatively large size of the second coil 12 enhances retention of the  
20 stent 10 in the kidney. The same can be said of other embodiments of the second coil such as the one shown in Figures 7 and 8 and 14-18.

The tapered tip on the second coil 14 (the renal coil) can facilitate inserting the stent through the passages of the patient's body. Additionally, a medical professional can use a suture connected to the stent 10 to reposition the stent (by pulling on it) when inserting the stent, and  
25 the medical professional can use the suture to remove the stent from the patient. For example, the medical professional either leaves the suture inside the patient's body or leaves the end of the suture outside the body. When the stent 10 is to be removed, the medical professional pulls on the suture, removing the stent. However, a suture does not have to be used to remove the stent  
10.

30           When placed in a patient's body, stents according to the invention may soften slightly, as might many thermoplastic materials when exposed to elevated temperatures, for example, but without limitation, by about 30% or less, or about 20% or less, or about 10% or less, or about 5% or less. However, such softening is not substantial. Softening can be measured by methods known in the art. For example, the ASTM test method described herein may be adapted to

determine if coils soften by determining if body temperature conditions cause a decrease in retention strength relative to room temperature conditions. However, other methods may be used.

An alternative method to straighten the coil 12 of the second section 20 is to produce  
5 relative movement between a straightening device (*e.g.*, a sheath) and second section 20, such  
that the straightening device moves distally relative to the second section 20, thereby uncurling  
the coil 12 to a straightened position. Once at least some portion of the second section 20 is  
positioned within the kidney 100, the straightening device is removed. The second section 20 is  
constructed from a shape-memory material. Thus, once the straightening device is withdrawn,  
10 the coil 12 in the straightened position returns to its coiled shape. A similar re-coiling of the first  
coil 14 also occurs when the straightening device is withdrawn from that area of the stent 10.  
Other modes of inserting and/or straightening a device also are useful.

Variations, modifications, and other implementations of what is described herein will  
occur to those of ordinary skill in the art without departing from the spirit and the scope of the  
15 invention. Accordingly, the invention is to be defined not only by the preceding illustrative  
description.

What is claimed is:

## CLAIMS

- 1 1. A medical stent comprising:  
2 a first section defining a lumen and comprising a first coil completing more than one  
3 revolution, the first section comprising a first material having a first durometer value, wherein  
4 the first coil revolves about and is coaxial with an axis and wherein a distance from a first point  
5 to the axis, the first point at the center of a first cross-section of the first coil and on a line normal  
6 to the axis, is less than a distance from a second point to the axis, the second point at the center  
7 of a second cross-section of the first coil and on a line normal to the axis, the first point being  
8 closer to an origin of the first coil than the second point;  
9 a second section defining a lumen and comprising a second coil completing at least one  
10 revolution, the second section comprising a second material having a second durometer value,  
11 wherein the second durometer value is greater than the first durometer value; and  
12 the third section defining a lumen and located between the first and second sections and  
13 adjacent the origin of the first coil, at least a portion of the third section comprising a co-  
14 extrusion of the first and second materials.  
15
- 1 2. The stent of claim 1 wherein the axis generally extends along the third section.  
2
- 1 3. The stent of claim 2 wherein the second coil is offset from the axis.  
2
- 1 4. The stent of claim 1 wherein the third section comprises a shaft.  
2
- 1 5. The stent of claim 1 wherein the second coil is generally perpendicular to the first coil.  
2
- 1 6. The stent of claim 1 wherein the first material comprises ethylene vinyl acetate.  
2
- 1 7. The stent of claim 1 wherein the first material has a durometer value of about 70 to about  
2 90 on a Shore A scale.  
3
- 1 8. The stent of claim 1 wherein the second material has a durometer value of about 80 to  
2 about 95 on a Shore A scale.  
3

1 9. The stent of claim 1 wherein a cross-section of the lumen in at least one of the first,  
2 second, and third sections is circular.

1 10. The stent of claim 1 wherein a cross-section of at least one of the first, second, and third  
2 sections is circular.

1 11. The stent of claim 1 wherein at least one of the first, second, and third section comprises  
2 a radiopaque material.

1 12. The stent of claim 1 wherein the second coil has an outer diameter of at least about 2.0  
2 cm.

1 13. The stent of claim 1 wherein the first coil is sized such that at least a portion of the first  
2 coil resides at the junction of a bladder and a ureter in a patient.

1 14. The stent of claim 1 wherein the first coil comprises a spiral.

1 15. A method for placing a medical stent comprising:  
2 inserting a medical stent into a ureter, the medical stent comprising:  
3 a first section defining a lumen and comprising a first coil completing more than one  
4 revolution, the first section comprising a first material having a first durometer value, wherein  
5 the first coil revolves about and is coaxial with an axis and wherein a distance from a first point  
6 to the axis, the first point at the center of a first cross-section of the first coil and on a line normal  
7 to the axis, is less than a distance from a second point to the axis, the second point at the center  
8 of a second cross-section of the first coil and on a line normal to the axis, the first point being  
9 closer to an origin of the first coil than the second point;  
10 a second section defining a lumen and comprising a second coil completing at least one  
11 revolution, the second section comprising a second material having a second durometer value,  
12 wherein the second durometer value is greater than the first durometer value; and  
13 the third section defining a lumen and located between the first and second sections and  
14 adjacent the origin of the first coil, at least a portion of the third section comprising a co-  
15 extrusion of the first and second materials.

1 16. The stent of claim 15 wherein at least a portion of the first coil resides at the junction of a  
2 bladder and a ureter in a patient.

1 17. The stent of claim 16 wherein at least a portion of the first coil at least partially occludes  
2 the junction.

1 18. A medical stent comprising:

2 a first section defining a lumen and comprising a substantially planar first coil completing  
3 more than one revolution, the first section comprising a first material having a first durometer  
4 value;

5 a second section defining a lumen and comprising a second coil completing at least one  
6 revolution, the second coil being generally perpendicular to the first coil, the second section  
7 comprising a second material having a second durometer value, wherein the second durometer  
8 value is greater than the first durometer value; and

9 a third section defining a lumen and located between the first and second sections, at least  
10 a portion of the third section comprising a co-extrusion of the first and second materials.

1 19. A method for placing a medical stent comprising:

2 inserting a medical stent into a ureter, the medical stent comprising:

3 a first section defining a lumen and comprising a substantially planar first coil completing  
4 more than one revolution, the first section comprising a first material having a first durometer  
5 value;

6 a second section defining a lumen and comprising a second coil completing at least one  
7 revolution, the second coil being generally perpendicular to the first coil, the second section  
8 comprising a second material having a second durometer value, wherein the second durometer  
9 value is greater than the first durometer value; and

10 a third section defining a lumen and located between the first and second sections, at least  
11 a portion of the third section comprising a co-extrusion of the first and second materials.

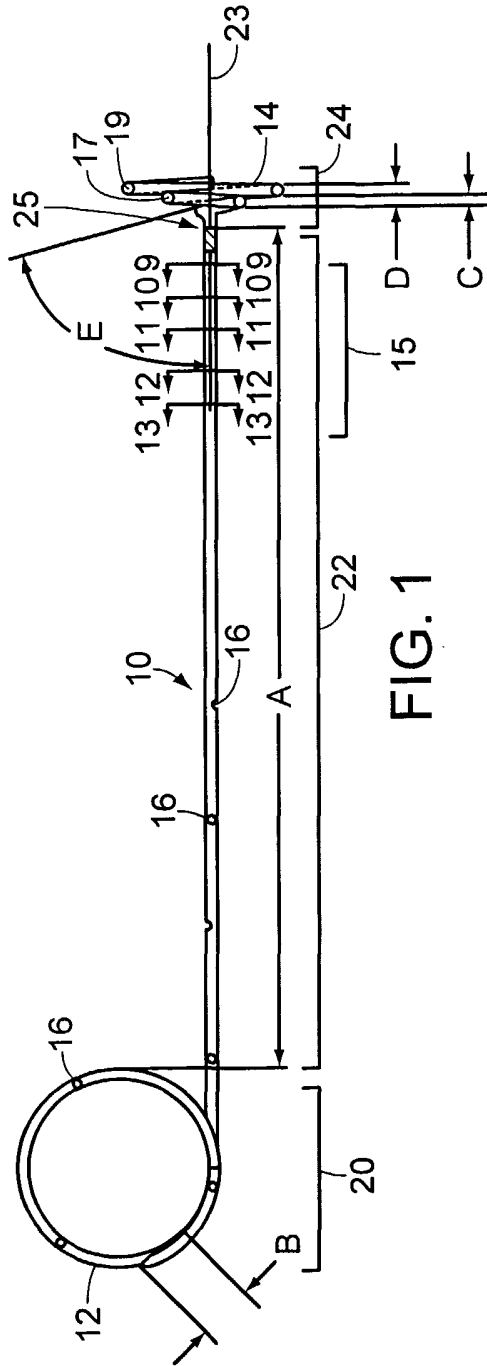

FIG. 1

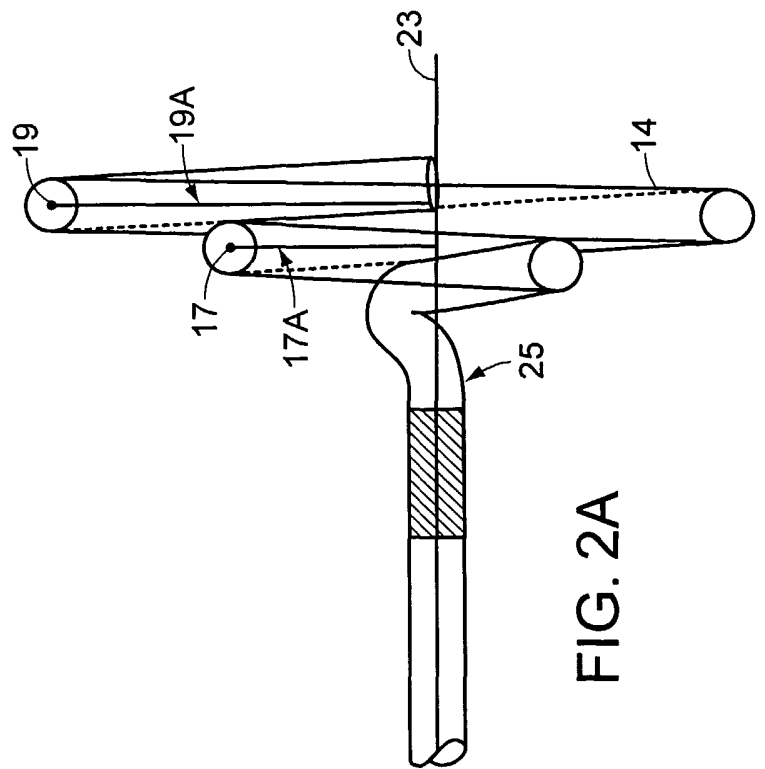

FIG. 2A

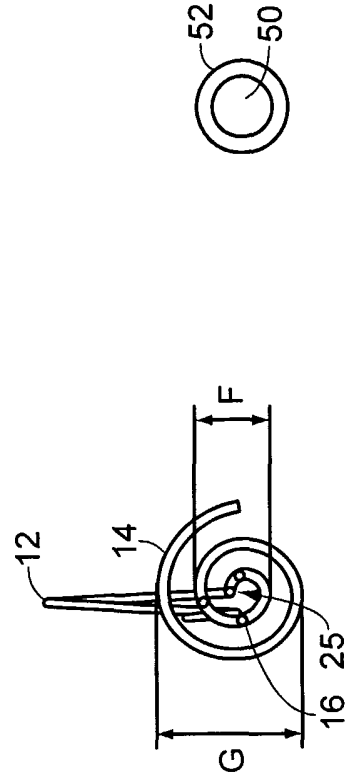

FIG. 2B

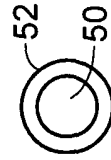

FIG. 3

FRENCH SIZE	"A" DIM +/- 1 cm	"B" DIM +/- 1 mm	DRILLED HOLE SIZE (REF)
4.8	24	4	.026"
4.8	26	4	.026"
4.8	28	4	.026"
6	24	4	.030"
6	26	4	.030"
6	28	4	.030"
7	24	7	.041
7	26	7	.041
7	28	7	.041
8	24	7	.041
8	26	7	.041
8	28	7	.041

FIG. 4



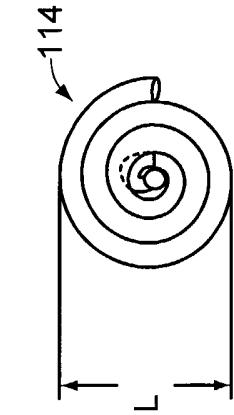

FIG. 6

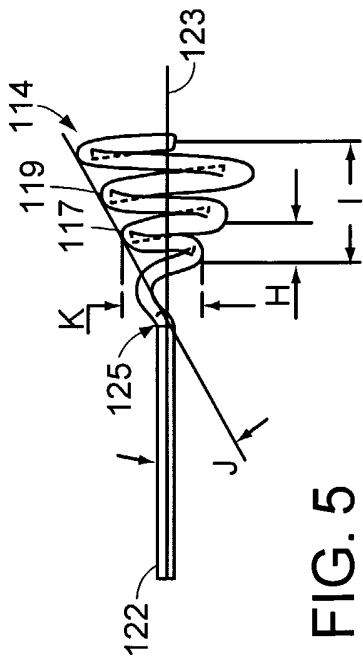

FIG. 5

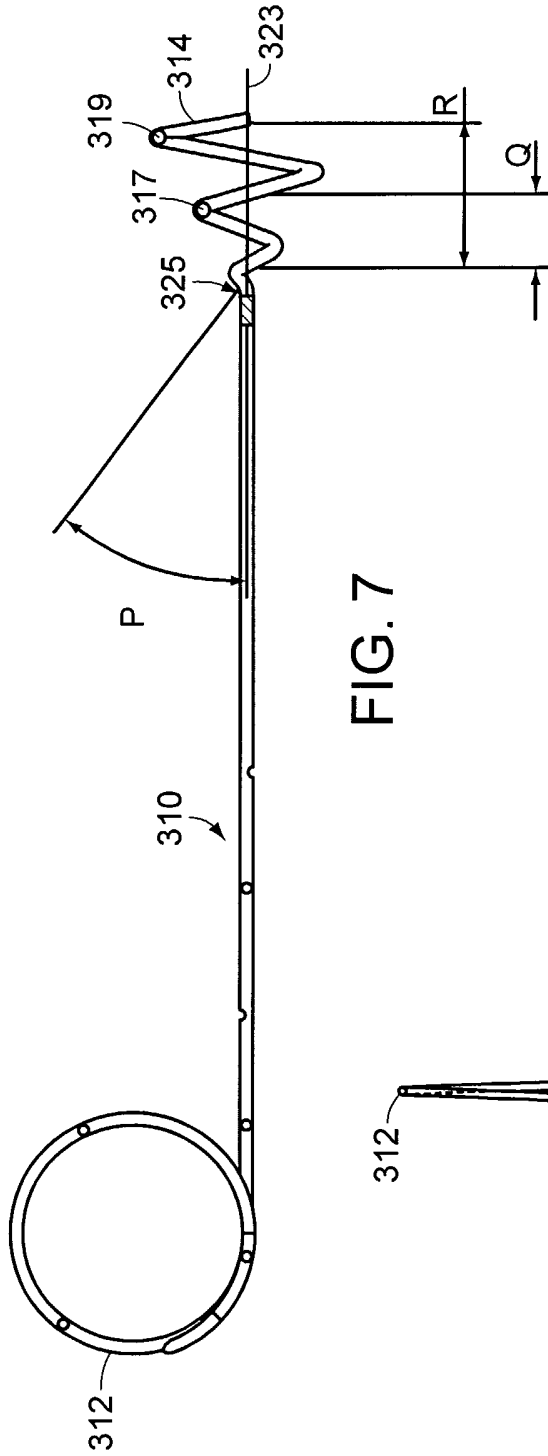

FIG. 7

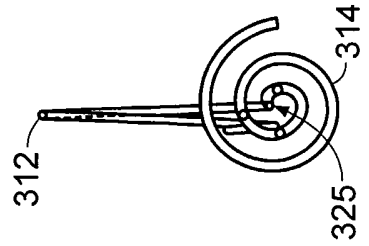

FIG. 8



FIG. 9



FIG. 10

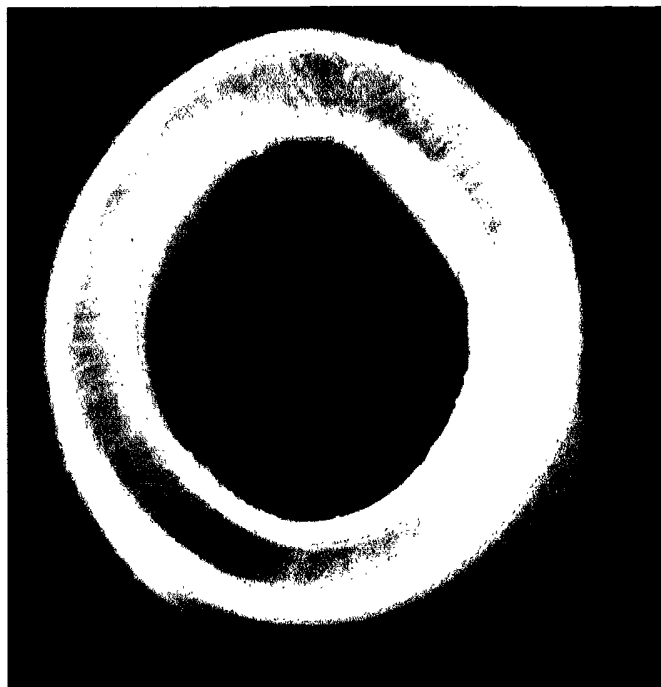

FIG. 11

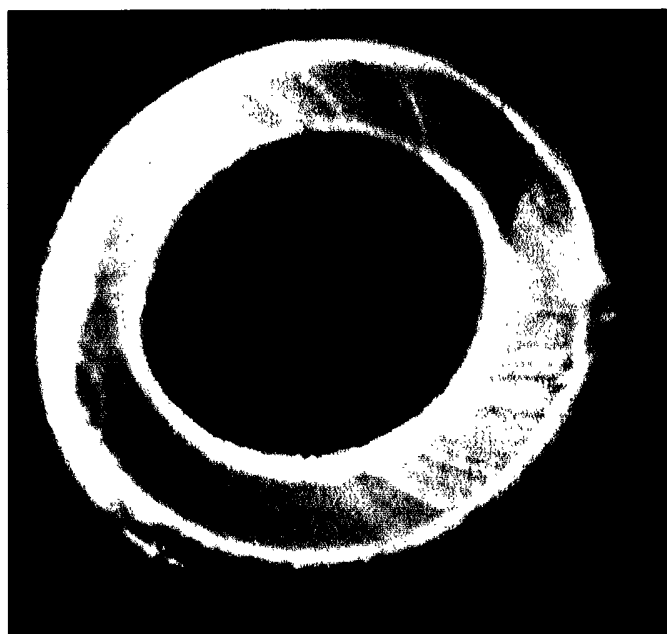

FIG. 12

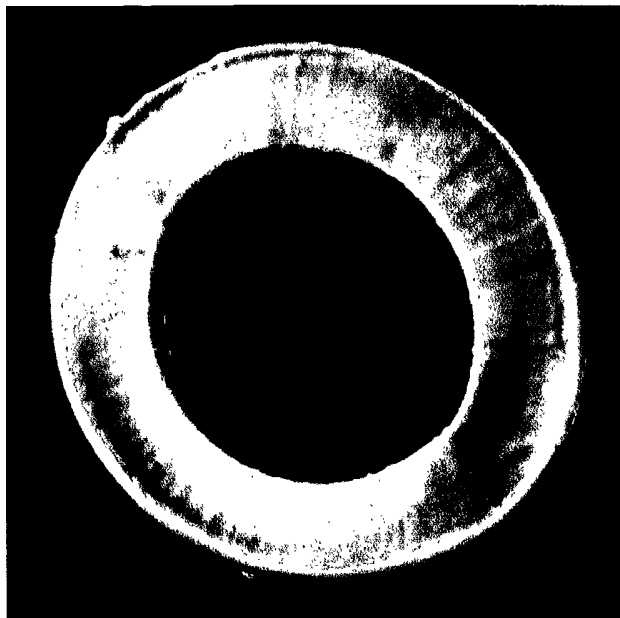

FIG. 13

FRENCH SIZE	AVERAGE O.D.	I.D.
4.3	.057±.001	.039±.001
5.3	.070±.002	.046±.002
6.3	.083±.002	.051±.002
7.3	.095±.002	.059±.002
8.3	.107±.002	.066±.002

FIG. 20

7/9

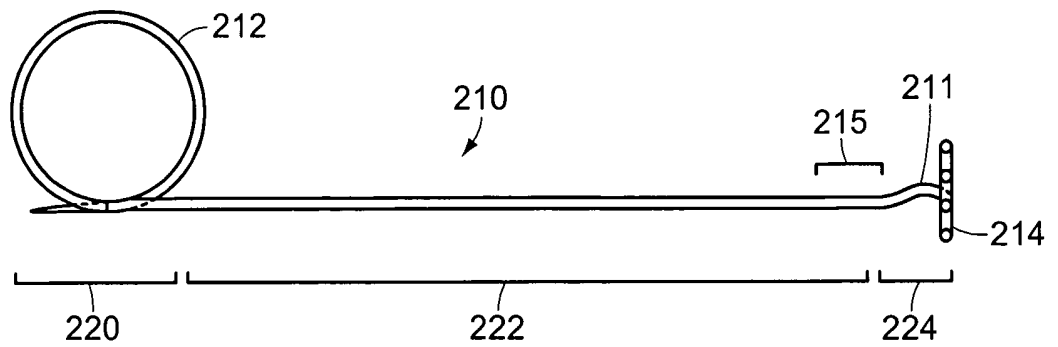

FIG. 14

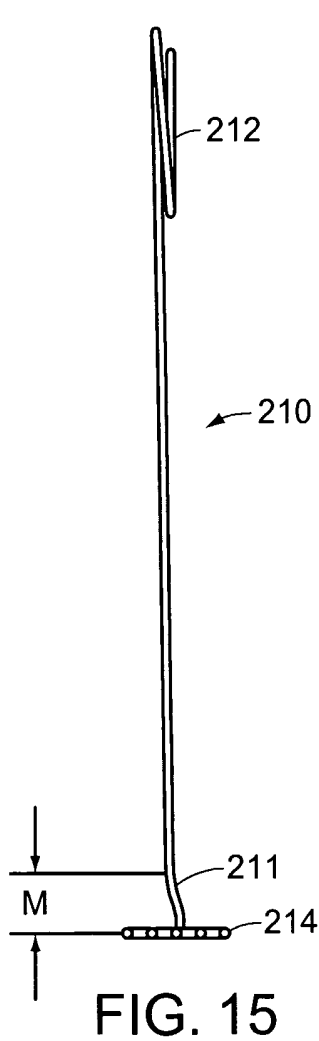

FIG. 15

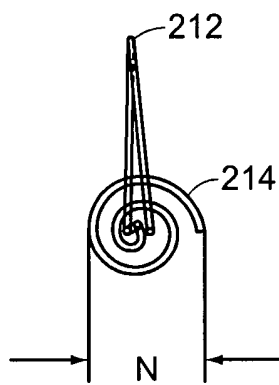

FIG. 16

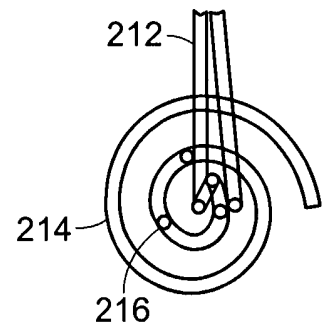

FIG. 17

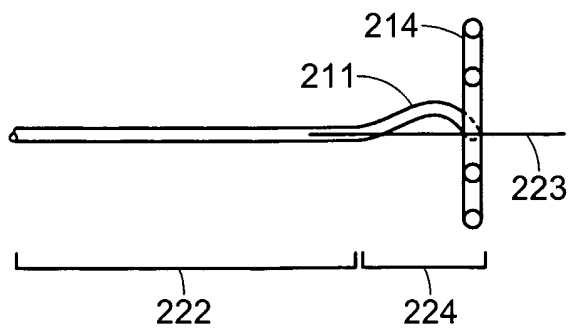

FIG. 18

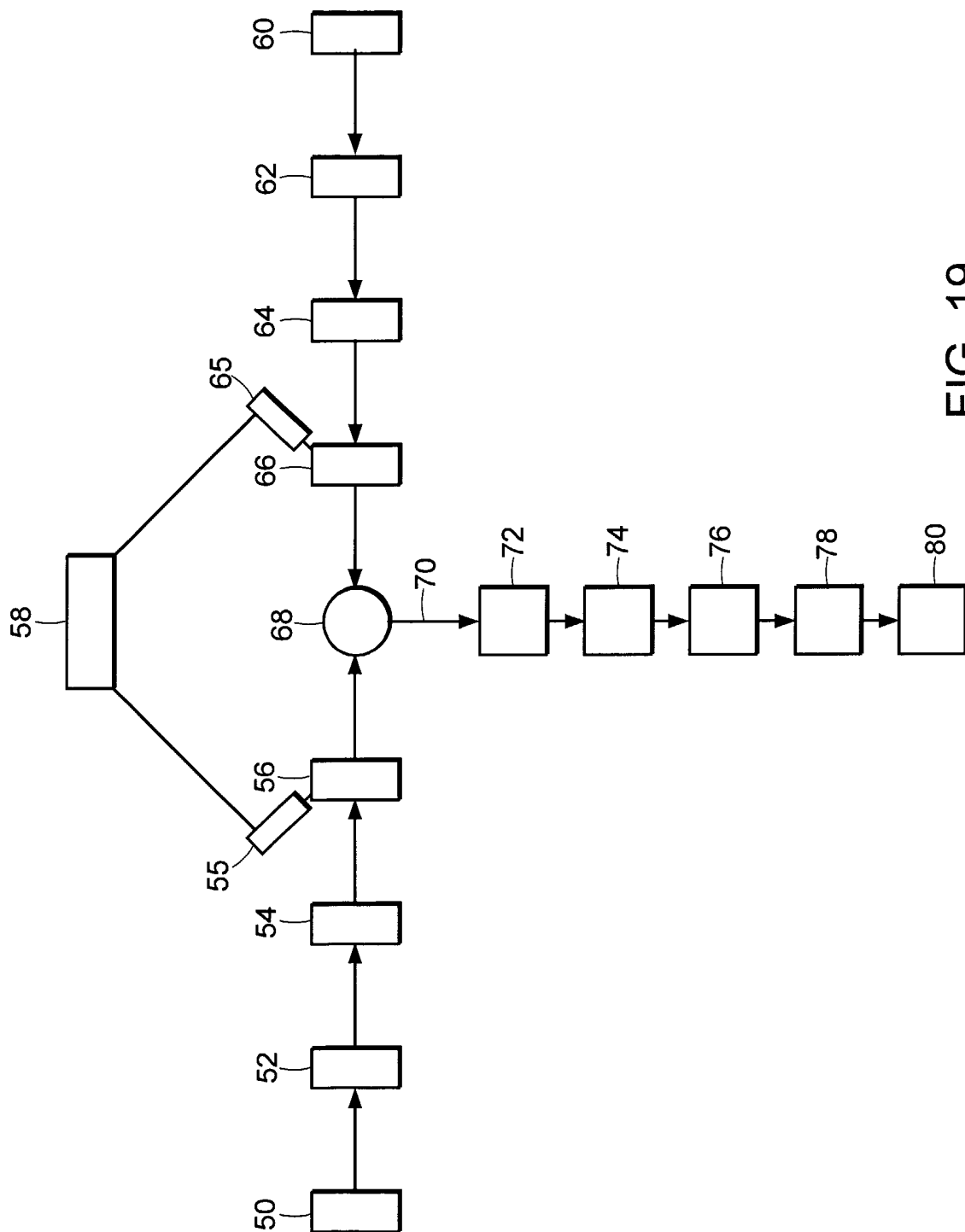

FIG. 19

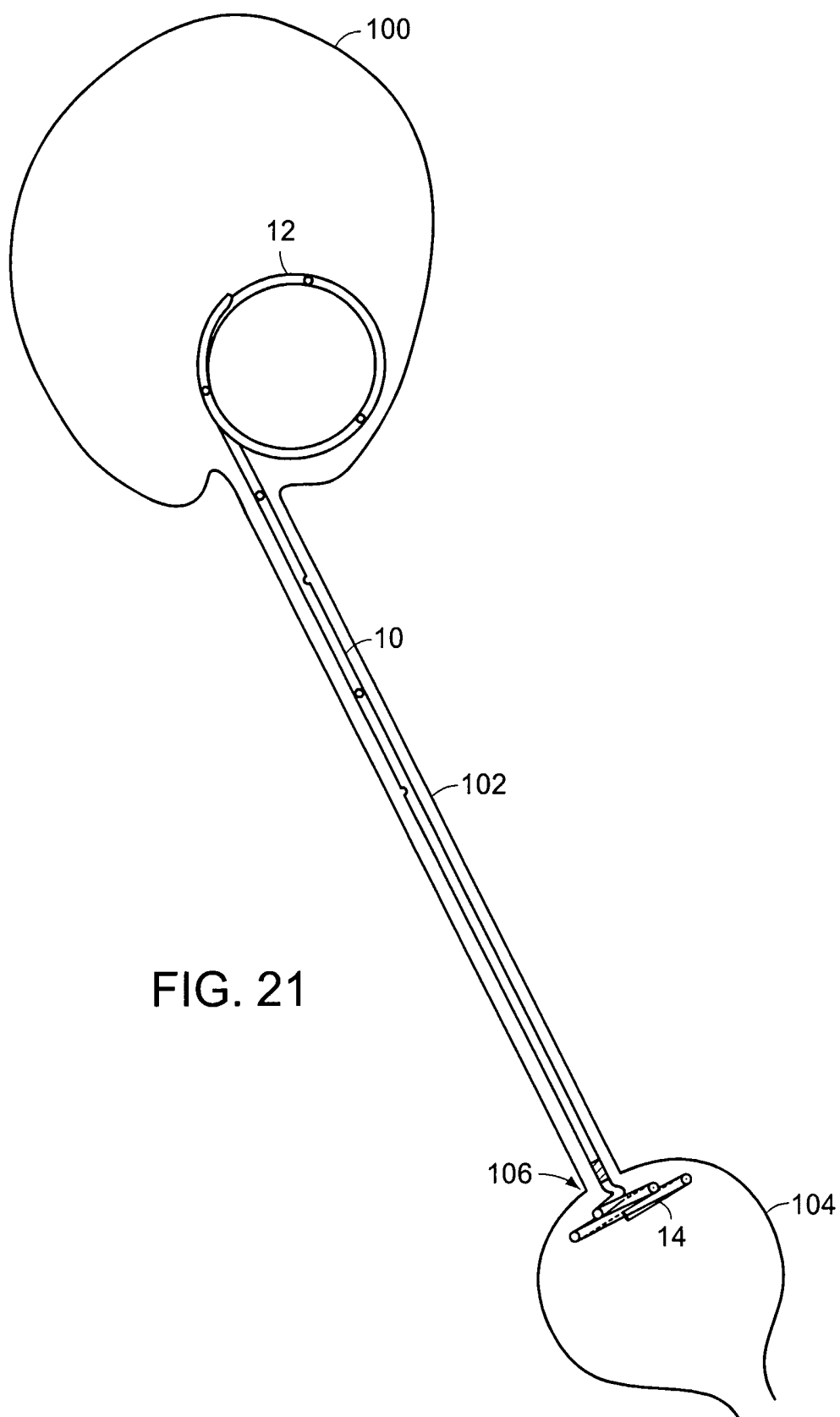

FIG. 21

## INTERNATIONAL SEARCH REPORT

Int onal Application No

PCT/US 02/09355

A. CLASSIFICATION OF SUBJECT MATTER  
IPC 7 A61M25/00 A61F2/04

According to International Patent Classification (IPC) or to both national classification and IPC

## B. FIELDS SEARCHED

Minimum documentation searched (classification system followed by classification symbols)  
IPC 7 A61M A61F

Documentation searched other than minimum documentation to the extent that such documents are included in the fields searched

Electronic data base consulted during the international search (name of data base and, where practical, search terms used)

EPO-Internal, WPI Data, PAJ

## C. DOCUMENTS CONSIDERED TO BE RELEVANT

Category °	Citation of document, with indication, where appropriate, of the relevant passages	Relevant to claim No.
A	US 4 874 360 A (GOLDBERG JAY R ET AL) 17 October 1989 (1989-10-17) column 3, line 26 -column 4, line 16; figures ---	1-4, 7-11,18
A	US 4 931 037 A (WETTERMAN PETER H) 5 June 1990 (1990-06-05) column 3, line 61 -column 4, line 33; figures ---	1-4, 9-11,18
A	US 4 531 933 A (WOLOSKY IRWIN S ET AL) 30 July 1985 (1985-07-30) column 3, line 8 - line 11; figures ---	1-5,9, 10,14,18
A	US 4 643 716 A (DRACH GEORGE W) 17 February 1987 (1987-02-17) the whole document --- -/--	1-4,9, 10,18



Further documents are listed in the continuation of box C.



Patent family members are listed in annex.

° Special categories of cited documents :

- \*A\* document defining the general state of the art which is not considered to be of particular relevance
- \*E\* earlier document but published on or after the international filing date
- \*L\* document which may throw doubts on priority claim(s) or which is cited to establish the publication date of another citation or other special reason (as specified)
- \*O\* document referring to an oral disclosure, use, exhibition or other means
- \*P\* document published prior to the international filing date but later than the priority date claimed

- \*T\* later document published after the international filing date or priority date and not in conflict with the application but cited to understand the principle or theory underlying the invention
- \*X\* document of particular relevance; the claimed invention cannot be considered novel or cannot be considered to involve an inventive step when the document is taken alone
- \*Y\* document of particular relevance; the claimed invention cannot be considered to involve an inventive step when the document is combined with one or more other such documents, such combination being obvious to a person skilled in the art.
- \*Z\* document member of the same patent family

Date of the actual completion of the international search

6 September 2002

Date of mailing of the international search report

12/09/2002

Name and mailing address of the ISA

European Patent Office, P.B. 5818 Patentlaan 2  
NL - 2280 HV Rijswijk  
Tel. (+31-70) 340-2040, Tx. 31 651 epo nl,  
Fax: (+31-70) 340-3016

Authorized officer

Kousouretas, I

1



## INTERNATIONAL SEARCH REPORT

International Application No

PCT/US 02/09355

## C.(Continuation) DOCUMENTS CONSIDERED TO BE RELEVANT

Category °	Citation of document, with indication, where appropriate, of the relevant passages	Relevant to claim No.
A	US 5 647 843 A (MESROBIAN HRAIR-GEORGE O ET AL) 15 July 1997 (1997-07-15) column 4, line 66 -column 5, line 2; figures ---	1-4, 9, 10, 18
A	US 5 141 502 A (MACALUSO JR JOSEPH N) 25 August 1992 (1992-08-25) column 3, line 3 - line 15; figures -----	1-4, 9, 10, 18

# INTERNATIONAL SEARCH REPORT

national application No.  
PCT/US 02/09355

## Box I Observations where certain claims were found unsearchable (Continuation of Item 1 of first sheet)

This International Search Report has not been established in respect of certain claims under Article 17(2)(a) for the following reasons:

1.  Claims Nos.: 15-17, 19  
because they relate to subject matter not required to be searched by this Authority, namely:  
Rule 39.1(iv) PCT - Method for treatment of the human or animal body by surgery
2.  Claims Nos.:  
because they relate to parts of the International Application that do not comply with the prescribed requirements to such an extent that no meaningful International Search can be carried out, specifically:
3.  Claims Nos.:  
because they are dependent claims and are not drafted in accordance with the second and third sentences of Rule 6.4(a).

## Box II Observations where unity of invention is lacking (Continuation of item 2 of first sheet)

This International Searching Authority found multiple inventions in this international application, as follows:

1.  As all required additional search fees were timely paid by the applicant, this International Search Report covers all searchable claims.
2.  As all searchable claims could be searched without effort justifying an additional fee, this Authority did not invite payment of any additional fee.
3.  As only some of the required additional search fees were timely paid by the applicant, this International Search Report covers only those claims for which fees were paid, specifically claims Nos.:
4.  No required additional search fees were timely paid by the applicant. Consequently, this International Search Report is restricted to the invention first mentioned in the claims; it is covered by claims Nos.:

### Remark on Protest

- The additional search fees were accompanied by the applicant's protest.
- No protest accompanied the payment of additional search fees.

INTERNATIONAL SEARCH REPORT  
Information on patent family members

International Application No  
PCT/US 02/09355

Patent document cited in search report		Publication date	Patent family member(s)	Publication date
US 4874360	A	17-10-1989	DE 3921634 A1	04-01-1990
			FR 2633521 A1	05-01-1990
			JP 2052646 A	22-02-1990
			JP 2933948 B2	16-08-1999
-----				
US 4931037	A	05-06-1990	NONE	
-----				
US 4531933	A	30-07-1985	AT 391625 B	12-11-1990
			AT 427783 A	15-05-1990
			AU 563743 B2	23-07-1987
			AU 2118583 A	14-06-1984
			CA 1209754 A1	19-08-1986
			CH 662513 A5	15-10-1987
			DE 3342163 A1	07-06-1984
			DK 559383 A	08-06-1984
			FR 2537001 A1	08-06-1984
			GB 2132091 A , B	04-07-1984
			JP 4054459 B	31-08-1992
			JP 59111748 A	28-06-1984
			NO 834486 A , B,	08-06-1984
			SE 454050 B	28-03-1988
SE 8306148 A	08-06-1984			
-----				
US 4643716	A	17-02-1987	CA 1232705 A1	16-02-1988
-----				
US 5647843	A	15-07-1997	CA 2205473 A1	24-11-1997
			EP 0808611 A2	26-11-1997
			JP 10052500 A	24-02-1998
-----				
US 5141502	A	25-08-1992	NONE	
-----				