

W. E. SCHNEIDER.
Station-Indicator.

No. 196,169.

Patented Oct. 16, 1877.

Fig. 1.

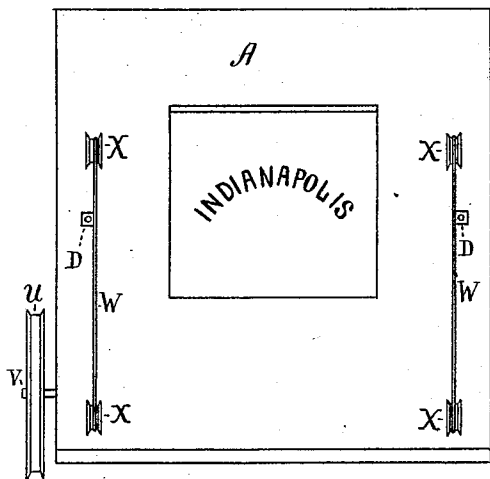

Fig. 2.

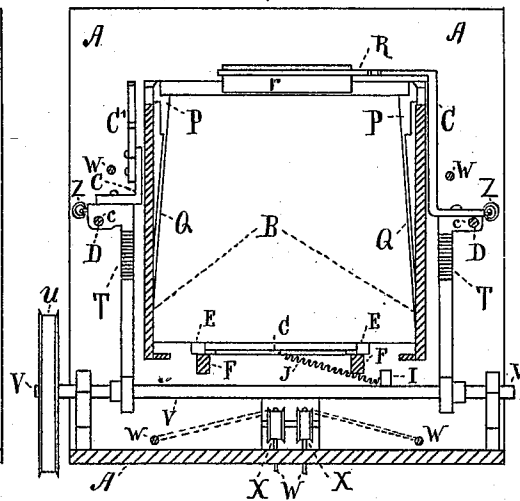
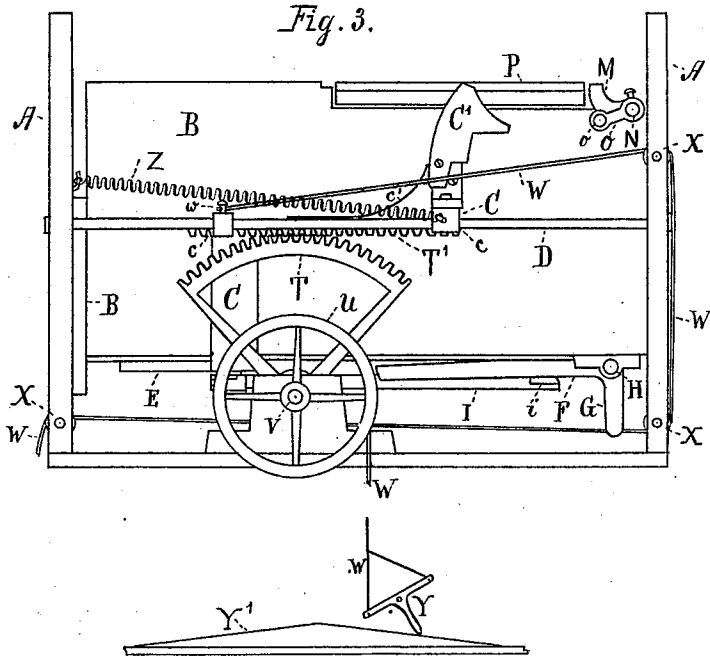

Fig. 3.



WITNESSES
James B. Liggins
R. P. Duggitt

INVENTOR
William E. Schneider,
per *C. Bradford*
Attorney

W. E. SCHNEIDER.
Station-Indicator.

No. 196,169.

Patented Oct. 16, 1877.

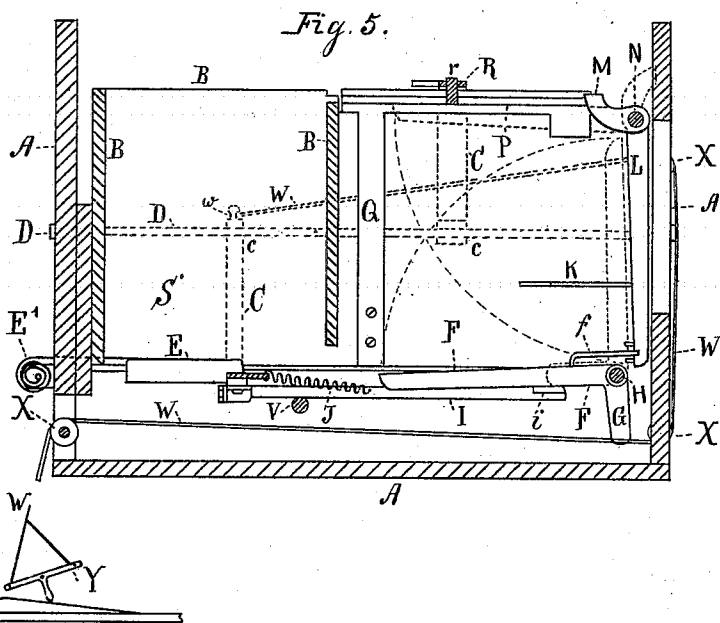
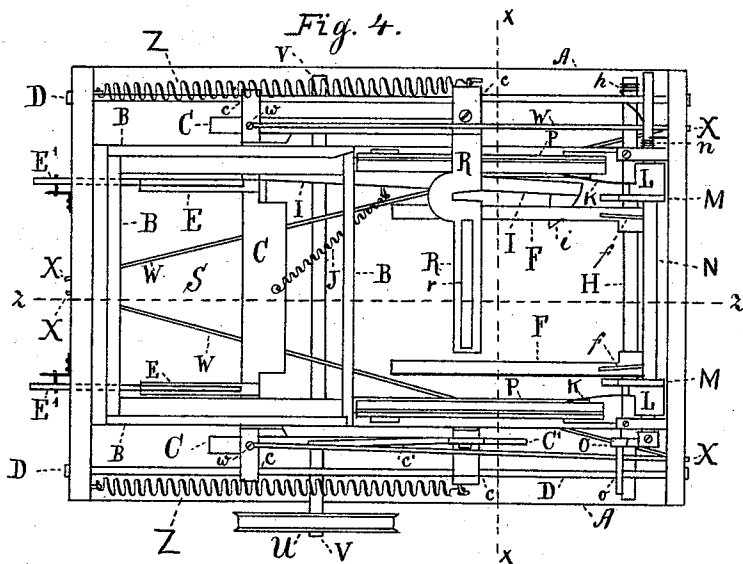

WITNESSES
James B. Liggins
R. P. Daggett

INVENTOR
Wm. E. Schneider,
C. Bradford
Attorney

UNITED STATES PATENT OFFICE.

WILLIAM E. SCHNEIDER, OF UNITED STATES ARMY.

IMPROVEMENT IN STATION-INDICATORS.

Specification forming part of Letters Patent No. **196,169**, dated October 16, 1877; application filed August 29, 1877.

To all whom it may concern:

Be it known that I, WILLIAM E. SCHNEIDER, of the Signal Service, United States Army, and a resident of the city of Washington, District of Columbia, have invented certain new and useful Improvements in Station-Indicators, of which the following is a specification:

Reference is had to the accompanying drawings, which are made a part hereof, and on which similar letters of reference indicate similar parts.

Figure 1 is a front view of my invention, showing one of the indicator-cords in position, with the name "Indianapolis" printed thereon. Fig. 2 is a transverse vertical section looking rearwardly from the dotted line *x x*. Fig. 3 is a side elevation. Fig. 4 is a top or plan view, and Fig. 5 is a longitudinal vertical section, looking to the right from the dotted line *z z*. Figs. 1 and 2 are views, with the forward end to the front. Figs. 3, 4, and 5 have the forward end turned to the right, and the sliding frame C in a position about halfway forward. Fig. 5, by means of dotted lines, shows the arms E E and L L, together with the short arms attached thereto, in the positions they occupy while being operated. The other dotted lines in this figure show portions of the machinery on the opposite side of the machine.

The object of my invention is to provide a convenient and efficient means by which the names of the stations or streets which the cars are approaching can be plainly indicated to the passengers on railway or street cars during the time that elapses while the cars are passing from one station or street to another. This is accomplished by a machine constructed for the purpose, in which—

Referring to the drawings, A is the outer frame or case; B, the inner or supporting frame-work for the machinery; C, a sliding or movable frame, which carries a portion of the working parts and operates the others, by engaging with them or their connections. D D are rods or slides on which the sliding frame C runs, and *c c c c* the bearings of the frame C on the rods D D.

The means of indicating the stations or streets with my invention consists in the use

of a series of rectangular cards (not shown in the drawings except in Fig. 1, where one is shown in position) equal in number to the number of stations or streets on the line to be traveled, and which are placed in the proper order in the card-receptacle S, whence they are drawn as required. E E are upwardly-projecting points on the lower portion of the frame C, which are of a sufficient height to engage and draw forward a single card at each forward motion of said frame. F F are arms which receive the cards as drawn forward by the points E E, and afterward raise them to position as the frame C recedes. *f f* are wires inserted at the proper place in the arms, to keep the cards in the proper position vertically. G G are short downwardly-projecting arms at right angles to the arms F F, and secured to the same shaft therewith; one of which engages with the hooked arm I, and thus operates said arms F F. H is the shaft on which the arms F F and G G are secured. *h* is a coiled spring on the end of the shaft H, which returns it and the arms thereon to their ordinary position after being operated by the arm I. I is an arm provided with a hook, *i*, which is attached to the lower part of the frame C, and which, when said frame is brought forward, engages with the arm G, and as the frame C recedes so operates upon said arm G as to turn the shaft H, and thus force the arms F F upward, throwing the indicator-card thereon into position. *i* is the hook on the arm I, which enables it to engage with the arm G. J is a spring, which keeps the arm I in position, and at the same time enables it to move sufficiently to do its proper work.

K K are small flat springs, between which the cards are forced by the arms F F, and which hold said cards until removed by the arms L L. L L are arms pendent from the shaft N, which receive the cards from the arms F F, and which, at the proper time, raise said cards from their position, and deliver them upon the ledges P P, whence they are withdrawn into the card-receptacle S, by the cross-arm R. M M are short curved arms, which serve as stops, preventing the shaft N from revolving too far, and thus throwing the arms L L and the card which they carry above the tops of the ledges P P. N is a shaft, on which

are situated the arms L L and M M, and also the crank-arm O. O is a crank-arm, having crank-pin *o* on the shaft N, through which said shaft and the arms thereon are operated, by the movable lug C' on the frame C, while said frame is moving forward. This lug C' has a joint of such construction that it is held rigid while moving forward, and forces the crank-pin upward with certainty and precision, but, being easily movable in the other direction, the weight of the shaft N and its attachments is sufficient to overcome it, and they are not, therefore, moved by its rearward motion. P P are ledges, which receive the cards from the arms L L. Q Q are spring standards, which support the ledges P P, and which are sufficiently flexible that they will recede from the pressure of the card as it is raised by the arms L L, and allow it to pass upon the ledges P P. R is a cross-arm, attached to the sliding frame C, by which the card is withdrawn from the ledges P P into the card-receptacle S, whence it is again taken in its turn by the points E E. *r* is a downwardly-projecting piece from the arm R, which engages the card. S is a receptacle of substantially the size and shape of the cards, and into which they are placed, and from which they are taken and replaced, substantially in the manner and by the means hereinbefore described.

I have devised a double means of operating my machine, either of which may be used at pleasure. Both are best shown in Fig. 3, though all the figures illustrate them to some extent.

One means consists in the use of a segment of gear-wheel, T, which engages in a toothed bar or rack, T', on the side of the frame C and the wheel U, over which runs a cord, W. By pulling this cord the wheel and segment, (which are secured to a common shaft, V,) are made to rotate, carrying with them the frame C, and consequently operating the machine.

The other means consists in the use of a long cord, W, which attaches to the frame C at *w*, and passes over the pulleys X X X, and is operated in a similar manner to the cord attached to the wheel U.

Below Figs. 3 and 5 is shown, on a small scale, a section of track with a device, Y', having inclined faces beside it, while directly above it is the T-shaped device Y, to which the cord W is attached.

I design to have this device Y pivoted to the truck-frame of the car, so that when its perpendicular arm strikes the incline one of the horizontal arms must be forced downward, and, as the cord W is intended to be double for some distance on its lower end, and to have one strand attached to each one of the horizontal arms, the tipping of the device in either direction will pull the cord, and thus operate the machine.

In operation this device Y may be constructed in a single piece, as shown, or it may be divided into two pieces and placed on a shaft, the perpendicular arm only being placed

over the incline, with the horizontal ones more or less to one side.

For the purpose of throwing the machinery back in position after being released from the pull on the cords W, I use the coiled springs Z Z. These springs are constructed of considerable strength, and one end of each is attached to the frame-work, and the other to the sliding frame C.

For the purpose of holding the cards up to a level position in the receptacle S, while the points E E are forward, I attach to the top of said points flat coiled springs E' E', which run through to the outside of the frame-work, and are there held by suitable attachments.

I contemplate using an alarm-bell with my invention, which may be of any desired construction, and operated by an attachment to any moving part of the machine that is most convenient.

The operation of my invention is briefly as follows: The cord W being tightly drawn and attached to the horizontal arms of the device Y, the contact of said device with the inclined faced projection Y' will pull said cord and operate the machine. When desirable this device Y may be left off and some other substituted, or the cord may be pulled by hand, and thus dispense with the device altogether.

The machine itself operates by the motion of the sliding frame C, which, in moving forward, accomplishes two objects: the first is to engage and carry with it, by means of the points E E, one of the indicator-cards, and deliver it upon the arms F F; and the second is to raise the card already in position, by means of the arms L L, upon the ledges P P, which it does by striking the lug C' against the crank-pin on the shaft N. In returning to position, which it does by means of the springs Z Z, the sliding frame also accomplishes two objects: the first is to throw the card just brought forward up in front of the orifice, where it can be seen; and the second is to withdraw the card, just thrown on the ledges by the arms L L, back into the receptacle S, to be again used when the occasion returns.

It will be observed that the cards are reversed during the operation of going to and coming from the orifice, and thus by having a number of cards corresponding to the number of stations or streets in any route, and having them properly lettered on both sides, the indicator will automatically register each one, both going and returning, without any care whatever, after being once properly arranged, except to keep the machinery in order.

In places where it is undesirable to place the projections beside the track the device Y can be dispensed with and a hand-pull substituted. This may be either a shorter cord, a crank, or a lever, as is most convenient, and be operated by the person in charge of the car.

Having thus fully described my invention, what I claim as new, and desire to secure by Letters Patent, is—

1. In a station-indicator, the combination of the sliding carriage C having movable lug C' with the shaft N having crank O, for the purpose of operating the arms L L, substantially as herein shown and described.

2. In a station-indicator, the combination of the sliding frame C and the arm I having hook i with the shaft H having short projecting arms G, for the purpose of operating the arms F F, substantially as herein shown and described.

3. In a station-indicator constructed substantially as herein shown and described, the combination of the toothed segment T, rack-bar T', and sliding frame C, for the purpose of operating the indicator in the manner specified.

4. In a station-indicator, the cross-arm R arranged as shown, and operated by the sliding-frame C, for the purpose of withdrawing the indicator-cards into their receptacle, substantially as specified.

5. In a station-indicator, the ledges P P mounted on spring-standards Q Q, for the purpose of receiving the indicator-cards from the arms L L, substantially as herein shown and described.

In witness whereof I have hereunto set my hand and seal, at Indianapolis, Indiana, this 25th day of August, A. D. 1877.

WILLIAM E. SCHNEIDER. [L. S.]

In presence of—

C. BRADFORD,
ANDREW BILLING.