



US00D510721S

(12) **United States Design Patent** (10) **Patent No.:** **US D510,721 S**
Axelrod (45) **Date of Patent:** **** Oct. 18, 2005**

- (54) **BATTERY CARTRIDGE**
- (75) Inventor: **Michael Axelrod**, Roswell, GA (US)
- (73) Assignee: **Arris International, Inc.**, Suwanee, GA (US)
- (**) Term: **14 Years**
- (21) Appl. No.: **29/191,664**
- (22) Filed: **Oct. 10, 2003**

Related U.S. Application Data

- (62) Division of application No. 29/175,893, filed on Feb. 12, 2003, now Pat. No. Des. 489,678.
- (51) **LOC (8) Cl.** **13-02**
- (52) **U.S. Cl.** **D13/103**
- (58) **Field of Search** D13/103, 110;
429/96-100, 159, 163, 176

References Cited

U.S. PATENT DOCUMENTS

D414,159 S *	9/1999	Deslyper et al.	D13/103
D440,201 S *	4/2001	Huynh et al.	D13/103
D449,577 S *	10/2001	Nishio et al.	D13/103
6,380,713 B2 *	4/2002	Namura	320/112
D473,186 S *	4/2003	Grosfeld et al.	D13/103
6,583,600 B2 *	6/2003	Haga et al.	320/110

* cited by examiner

Primary Examiner—Alan P. Douglas
Assistant Examiner—Rosemary Tarcza
(74) *Attorney, Agent, or Firm*—John L. Doughty

CLAIM

The ornamental design for a battery cartridge, as shown and described.

DESCRIPTION

FIG. 1 illustrates a top perspective view of a battery cartridge looking from a connector end;

- FIG. 2 illustrates a perspective view thereof looking from a withdrawal end;
- FIG. 3 illustrates a bottom perspective view thereof;
- FIG. 4 illustrates a side elevation view thereof;
- FIG. 5 illustrates a plan view thereof looking from a top side thereof;
- FIG. 6 illustrates an elevation view of the connector end thereof;
- FIG. 7 illustrates an elevation view of the withdrawal end thereof;
- FIG. 8 illustrates a plan view looking from a bottom side thereof;
- FIG. 9 illustrates a top perspective view of a second embodiment of a battery cartridge without chamfered edges looking from a connector end;
- FIG. 10 illustrates a perspective view thereof without chamfered edges looking from a withdrawal end;
- FIG. 11 illustrates a bottom perspective view thereof without chamfered edges;
- FIG. 12 illustrates a side elevation view thereof without chamfered edges;
- FIG. 13 illustrates a plan view thereof without chamfered edges looking from a top side thereof;
- FIG. 14 illustrates an elevation view of the connector end thereof without chamfered edges;
- FIG. 15 illustrates a plan view looking from a bottom side thereof without chamfered edges; and,
- FIG. 16 illustrates an elevation view of the withdrawal end thereof without chamfered edges.

The broken lines throughout the drawings are included for the purpose of illustrating portions of the battery cartridge that form no part of the claimed design.

1 Claim, 16 Drawing Sheets

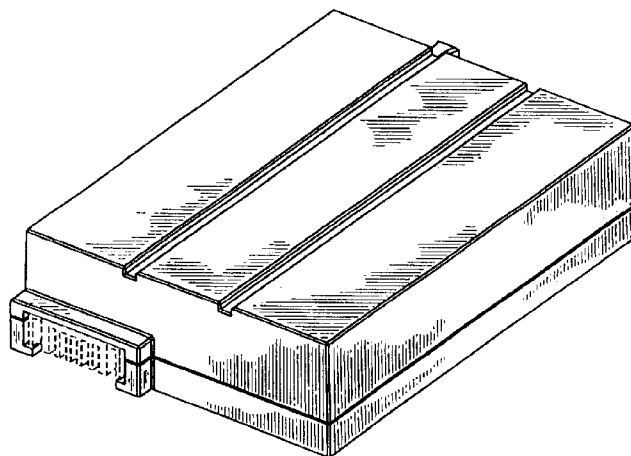

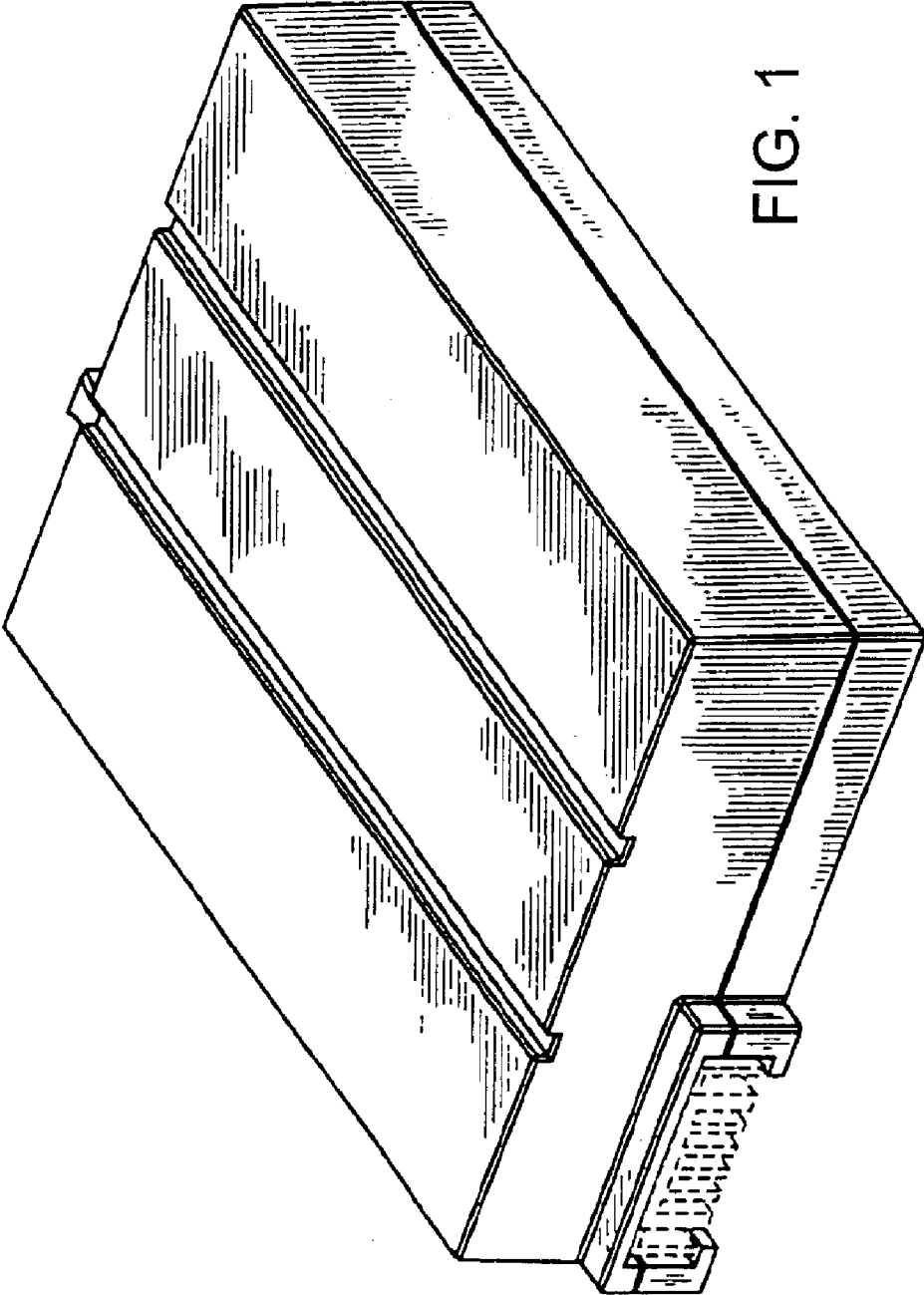

FIG. 1

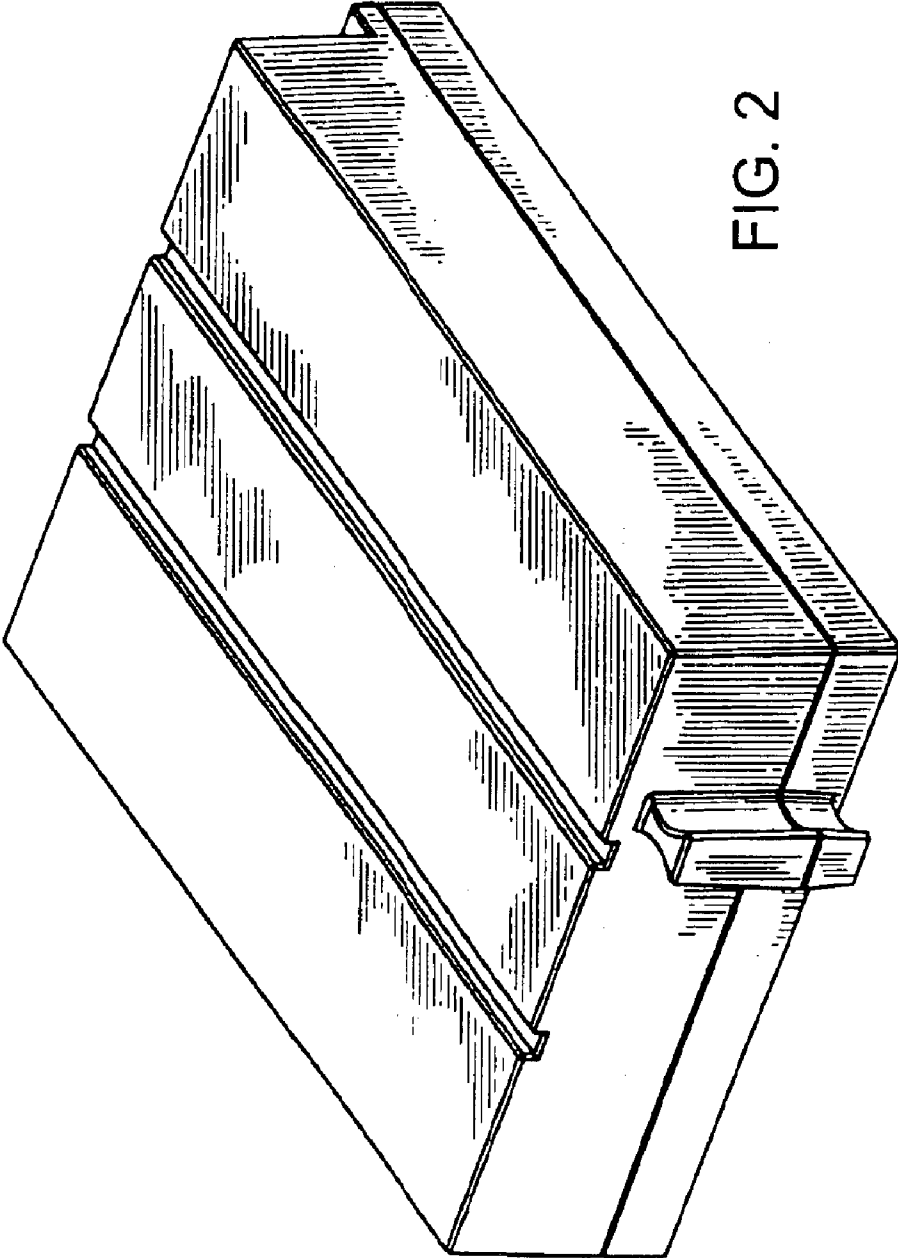

FIG. 2

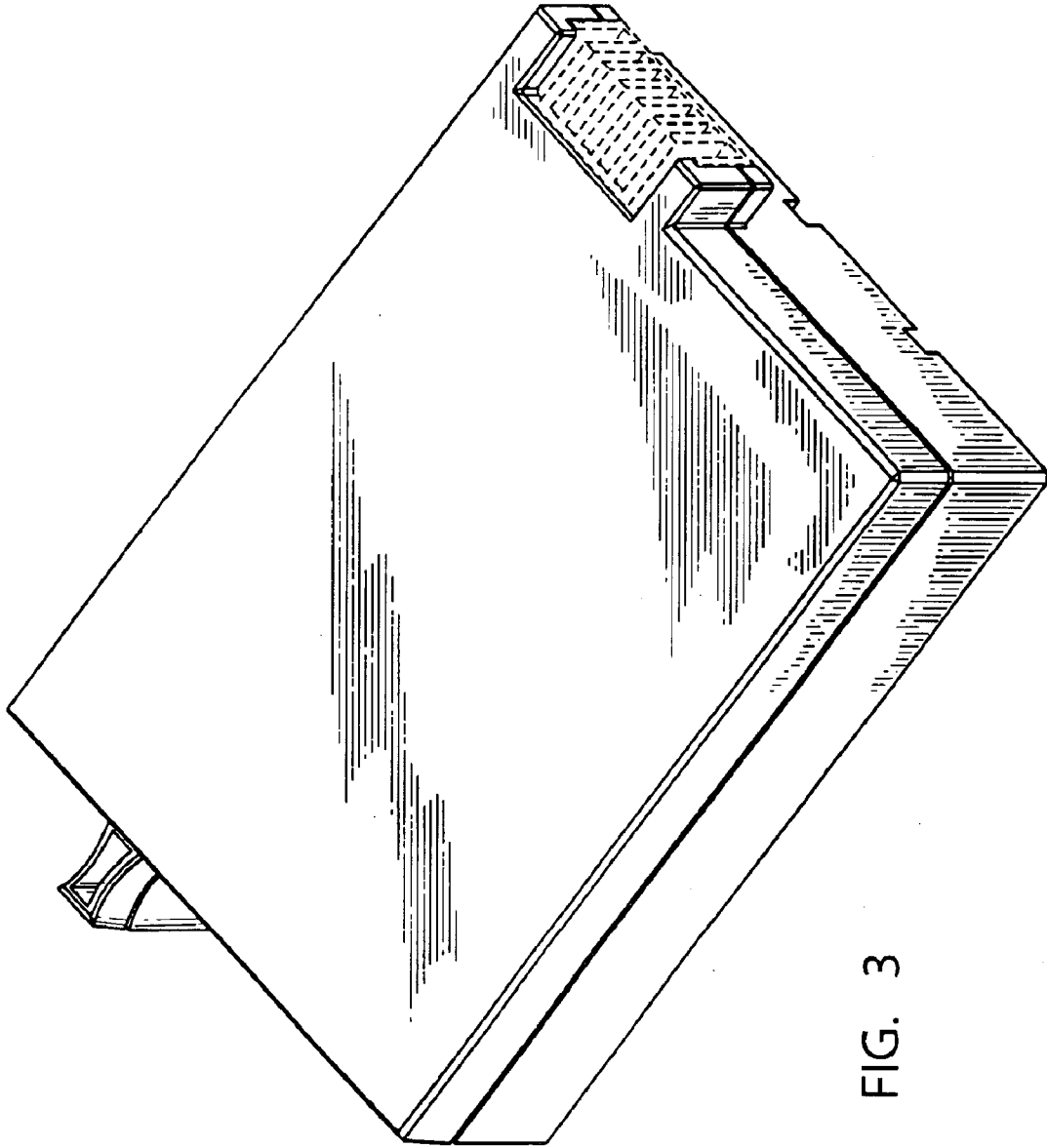

FIG. 3

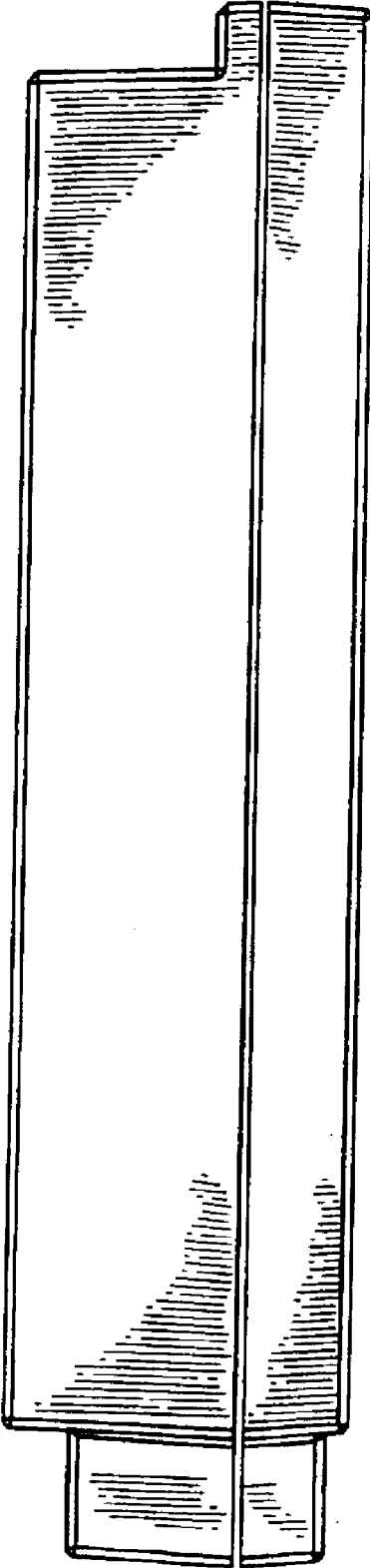

FIG. 4

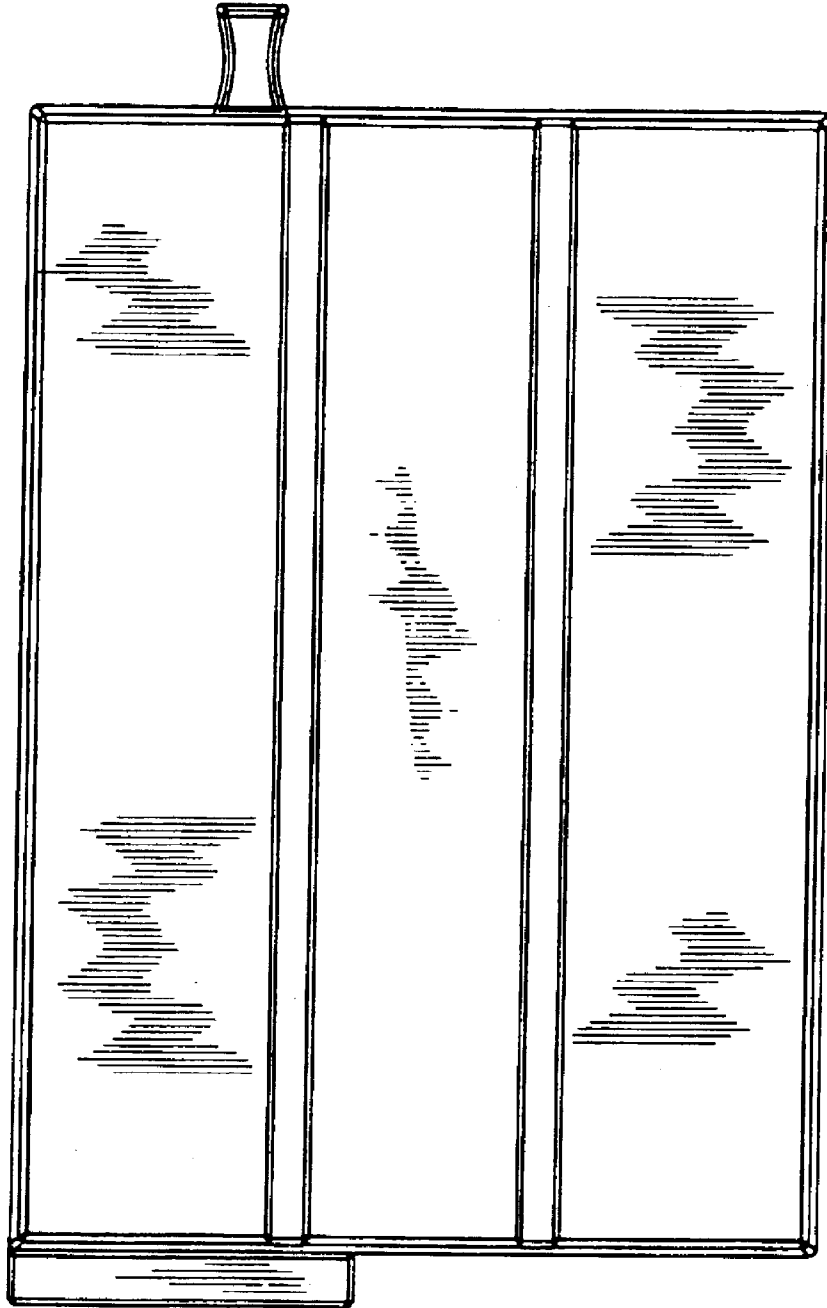

FIG. 5

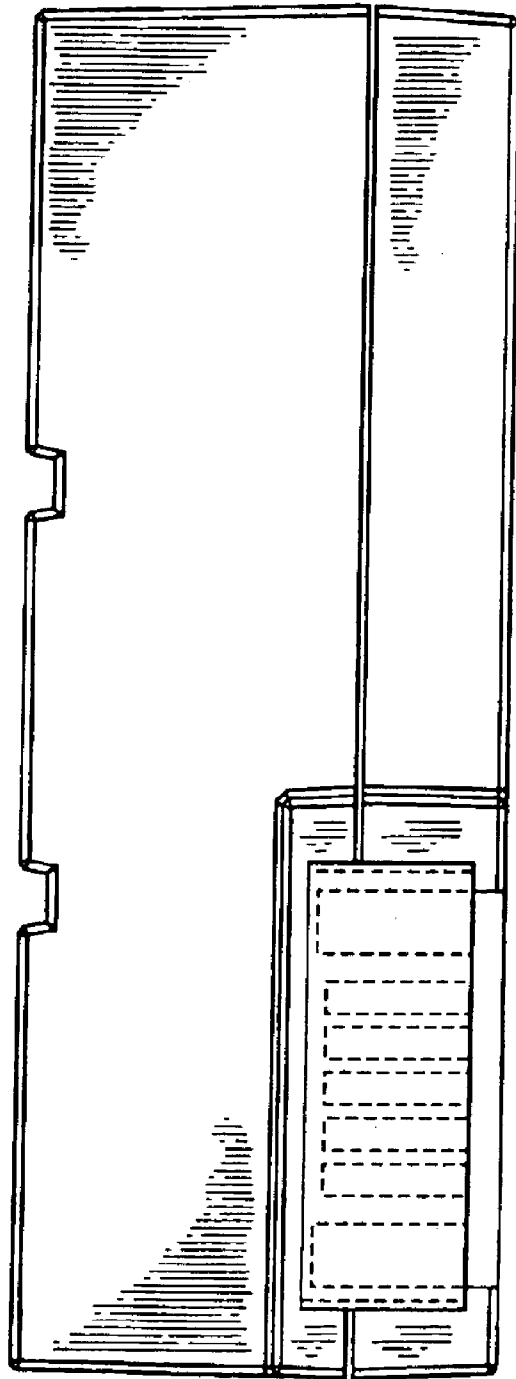

FIG. 6

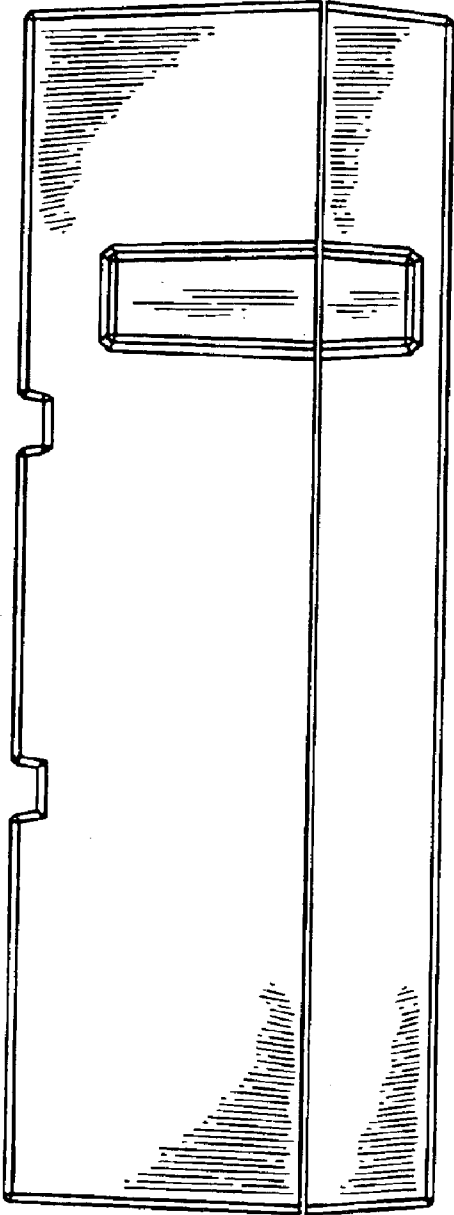

FIG. 7

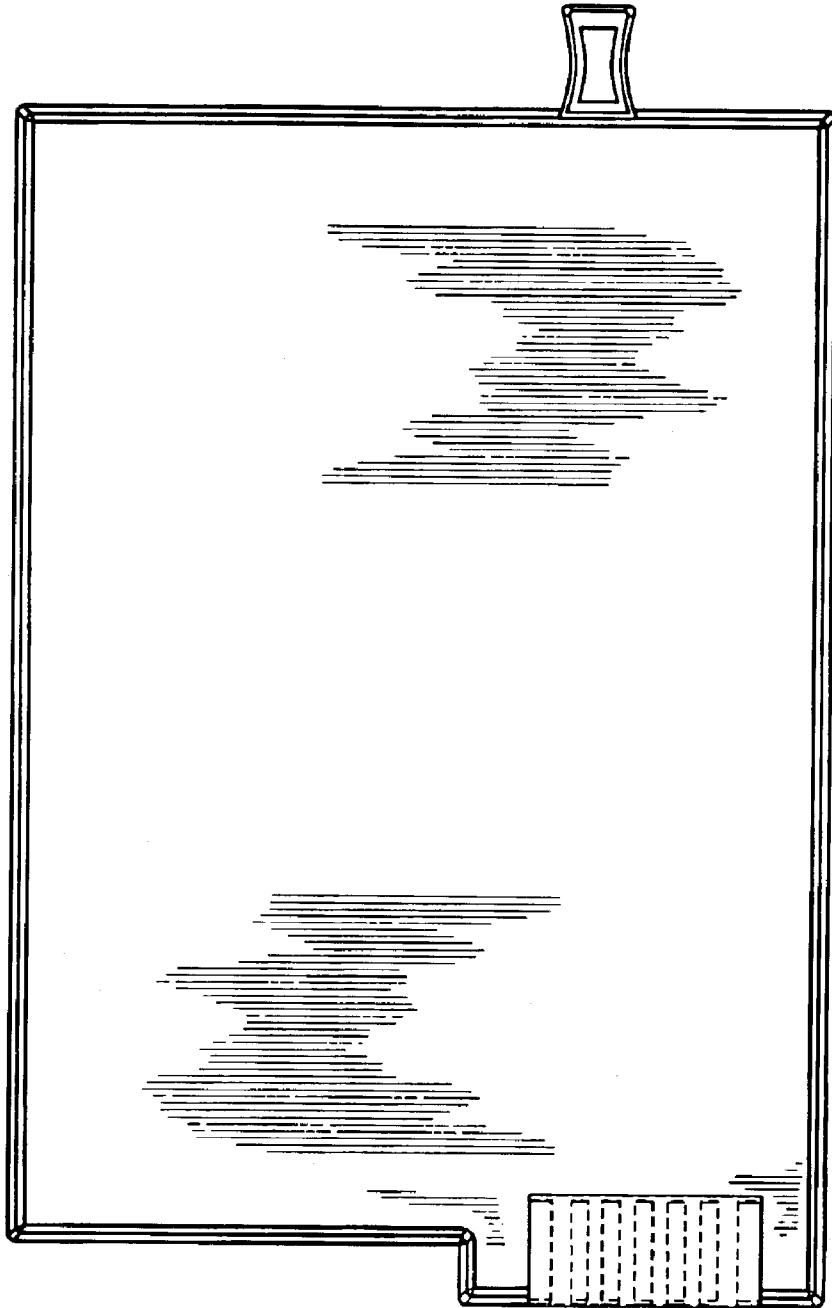

FIG. 8

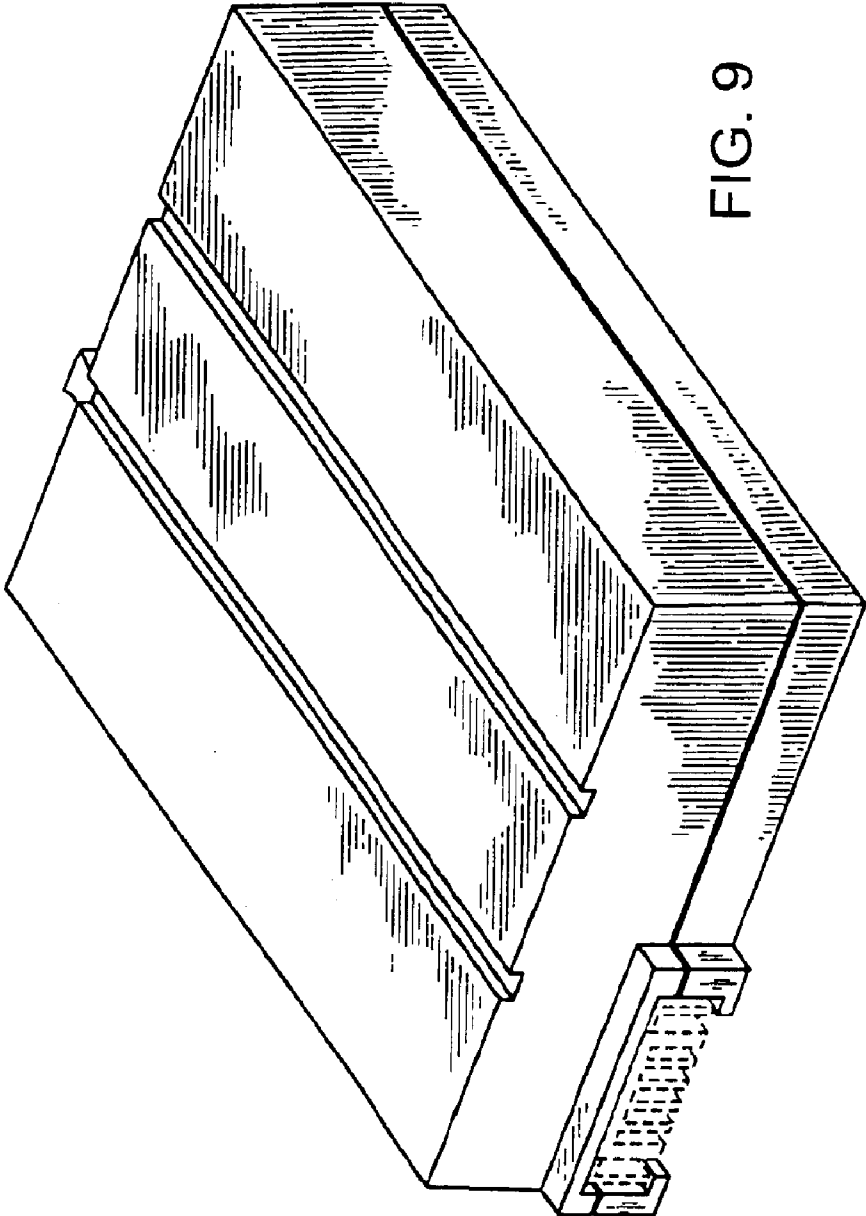

FIG. 9

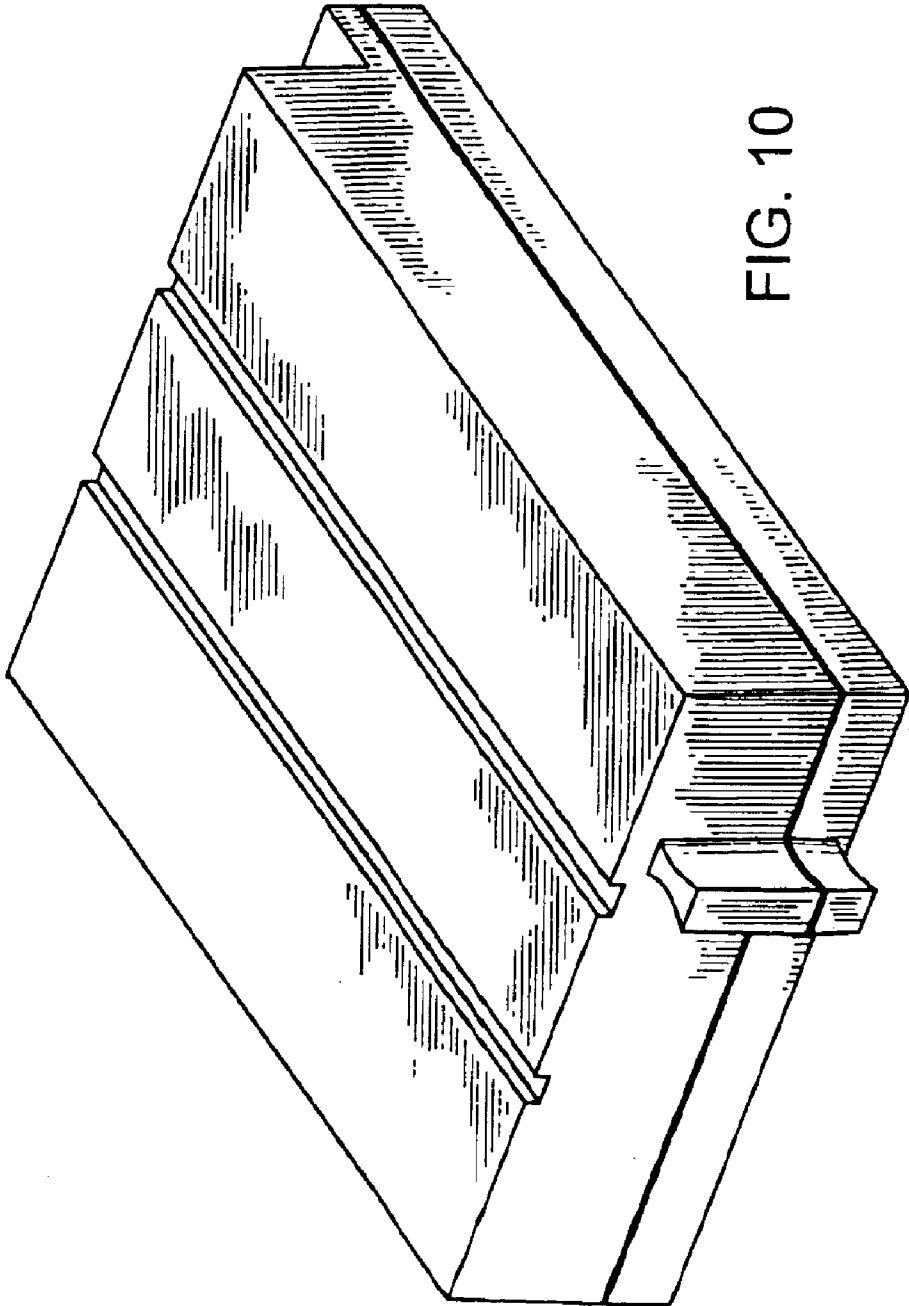

FIG. 10

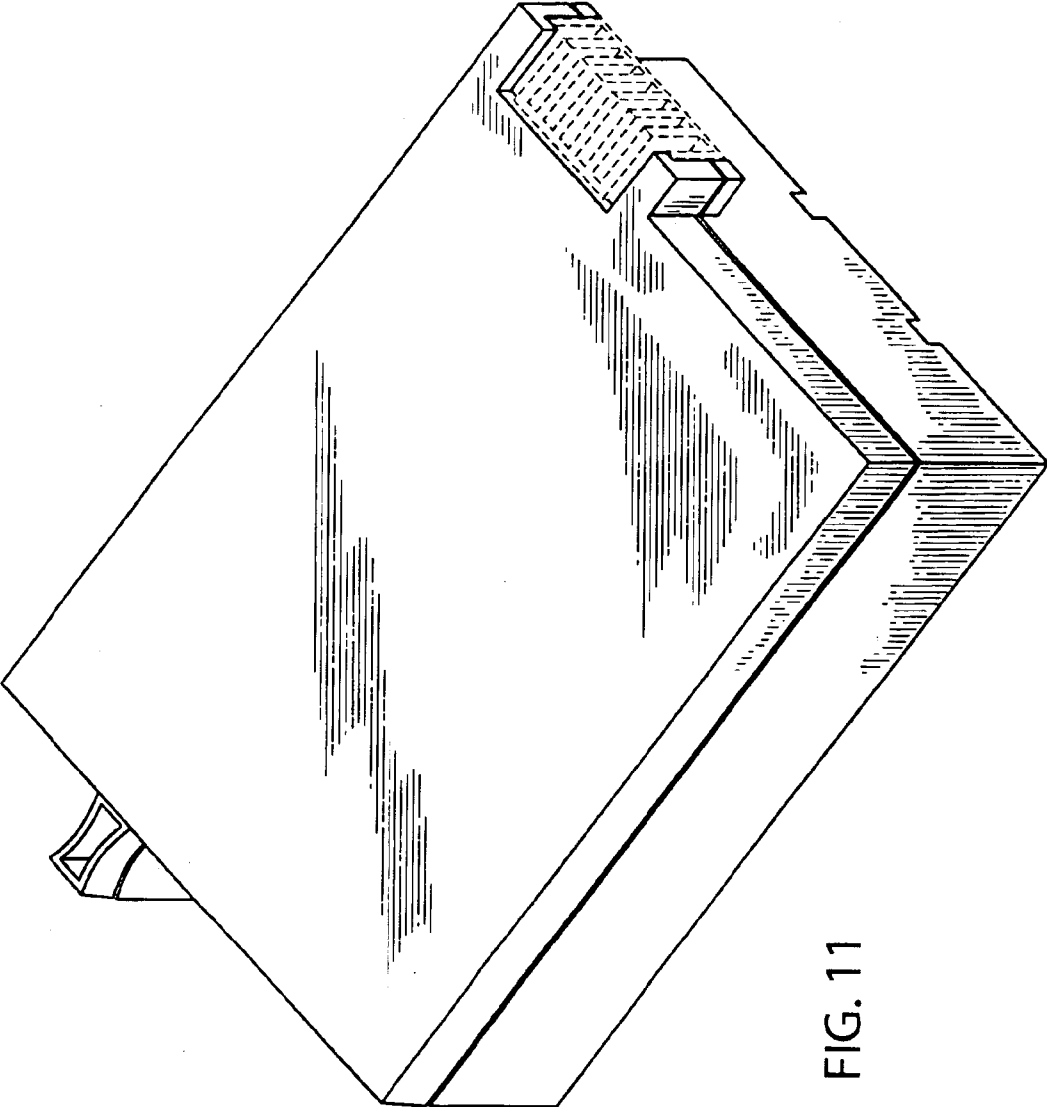

FIG. 11

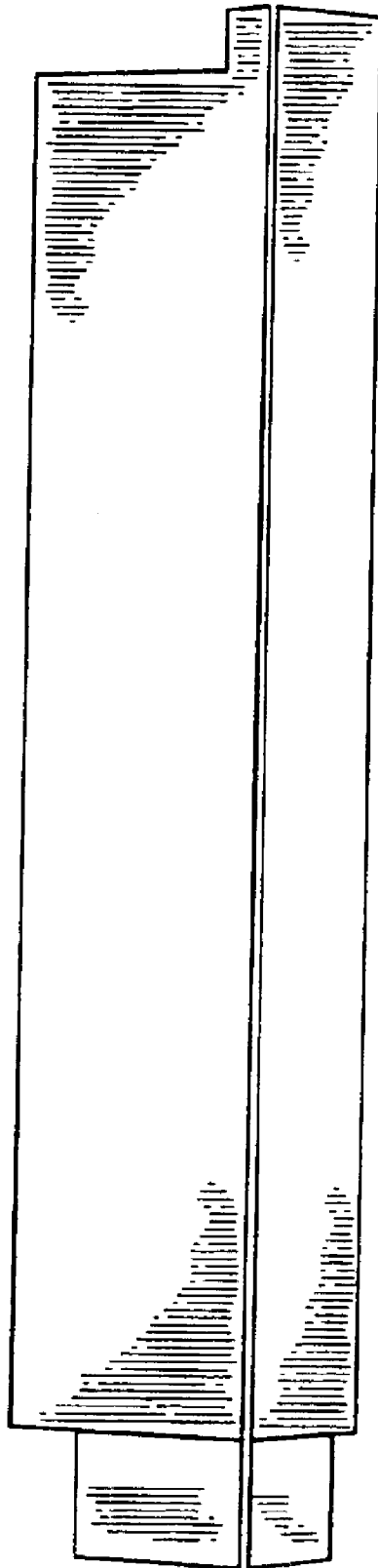

FIG. 12

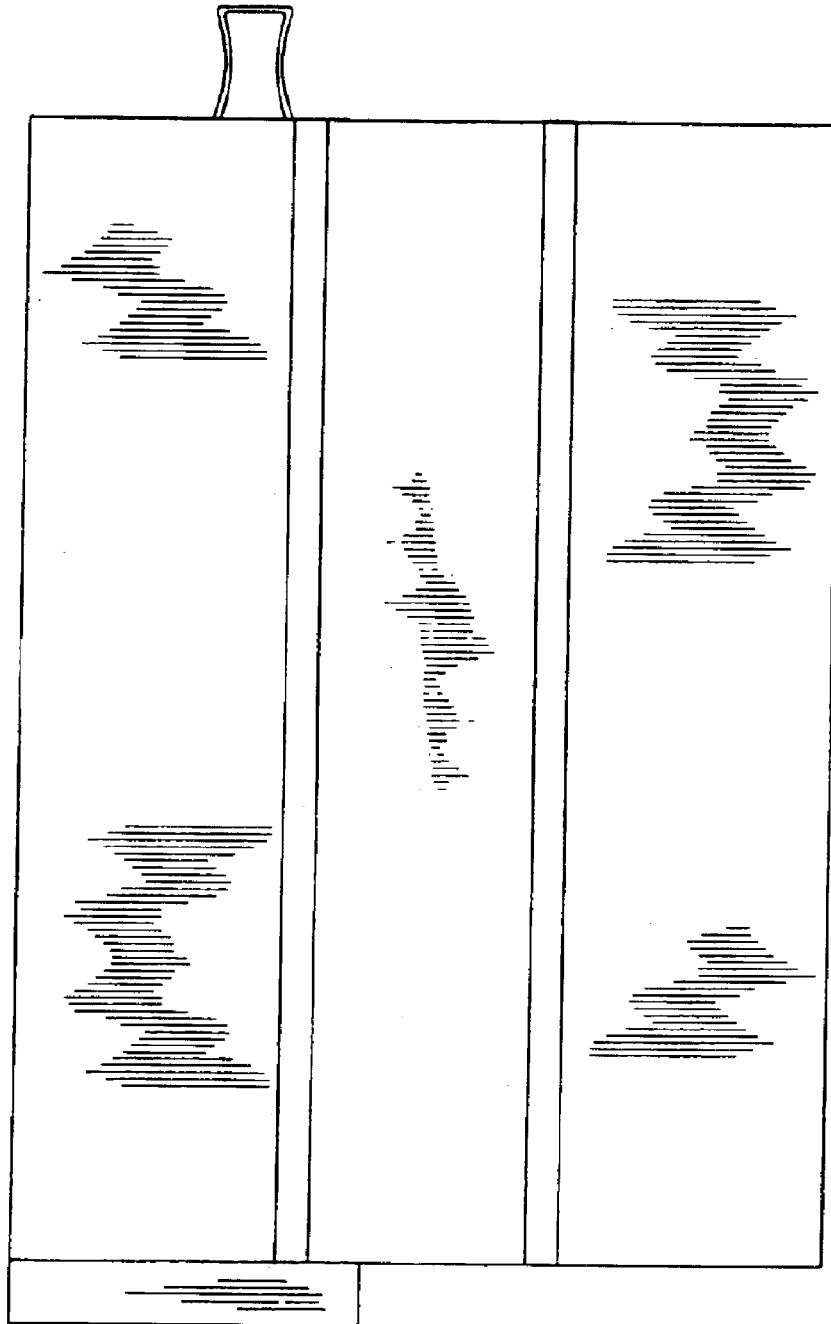

FIG. 13

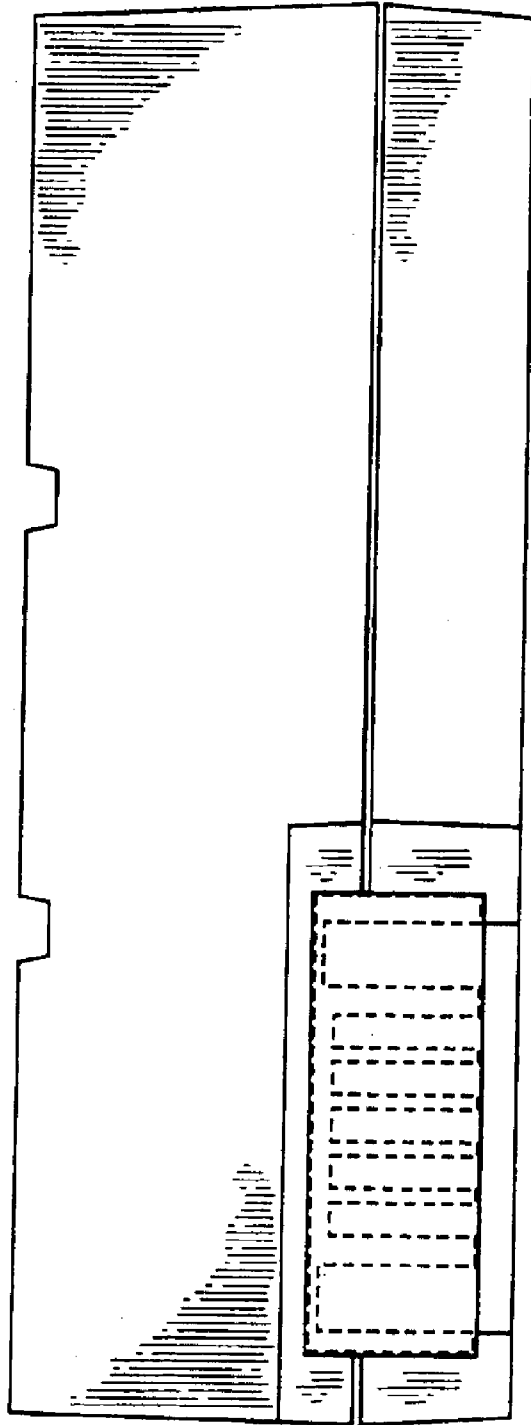

FIG. 14

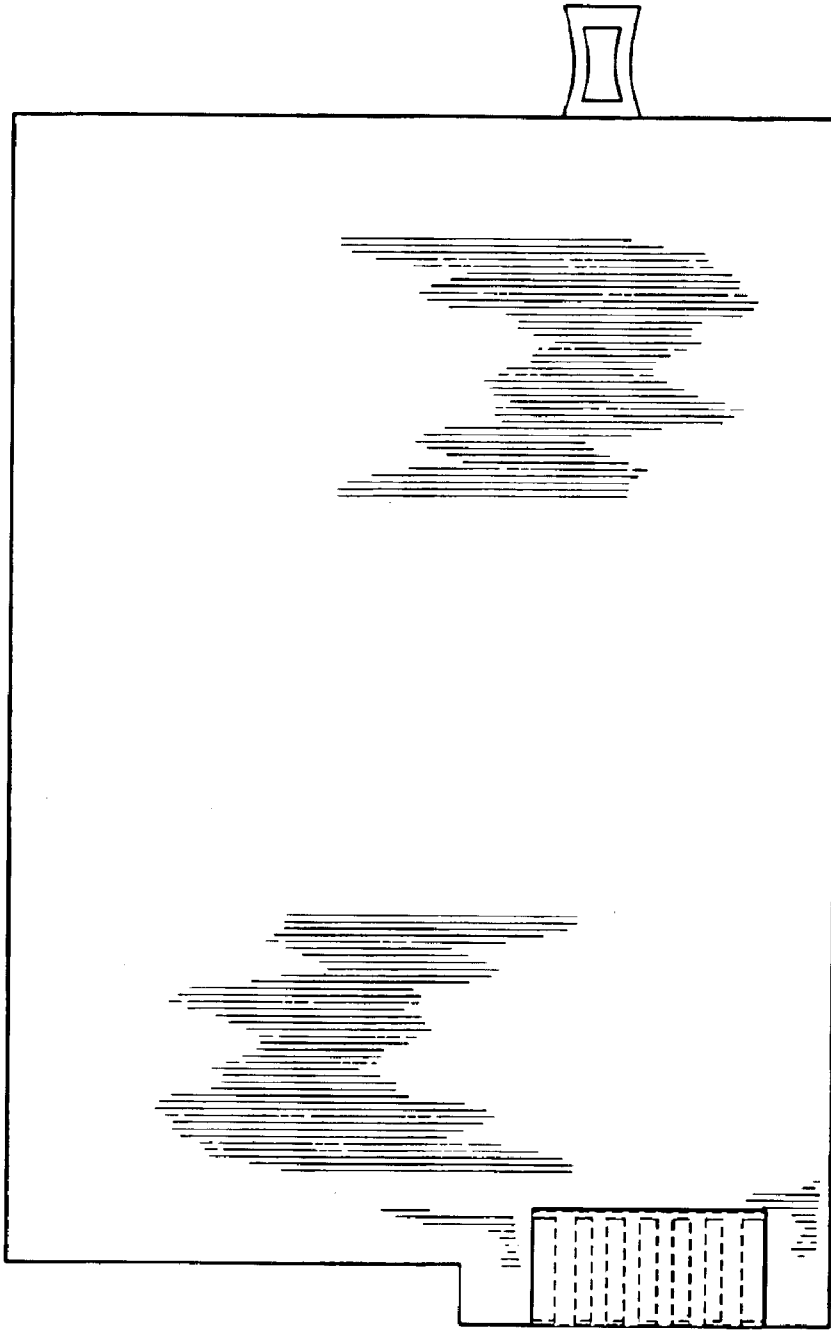

FIG. 15

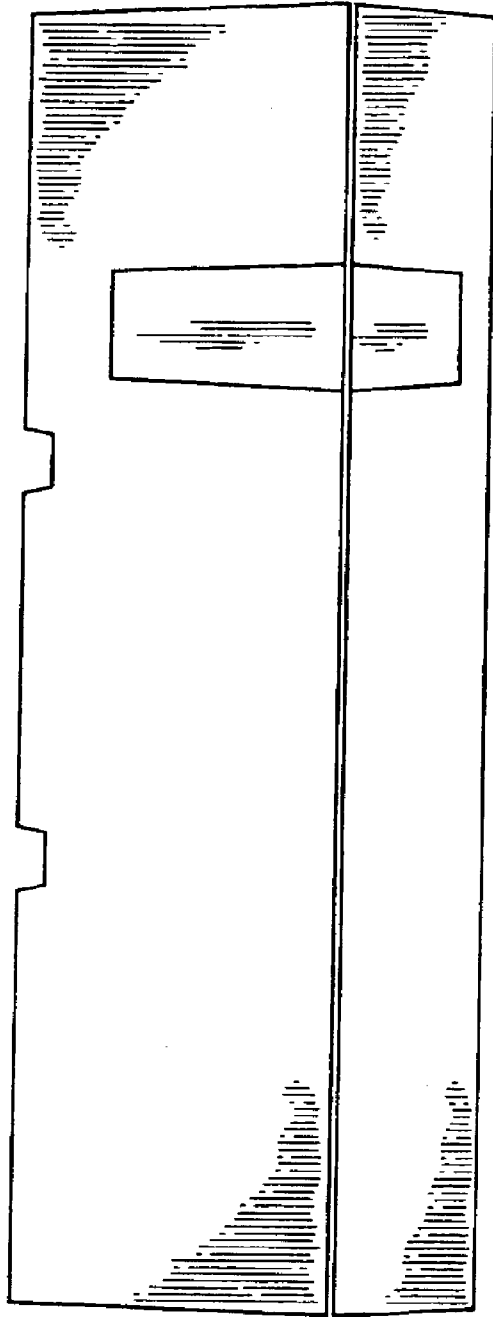

FIG. 16