

(12) PATENT
(19) AUSTRALIAN PATENT OFFICE

(11) Application No. AU 200035775 B2
(10) Patent No. 767652

(54) Title
Apparatus for propulsion in oblong cavities

(51)⁷ International Patent Classification(s)
F16L 055/40

(21) Application No: **200035775**

(22) Application Date: **2000.03.22**

(87) WIPO No: **WO00/57100**

(30) Priority Data

(31) Number	(32) Date	(33) Country
991368	1999.03.22	NO

(43) Publication Date : **2000.10.09**

(43) Publication Journal Date : **2000.12.07**

(44) Accepted Journal Date : **2003.11.20**

(71) Applicant(s)
AATechnology

(72) Inventor(s)
Harald Aadland

(74) Agent/Attorney
Hodgkinson And McInnes, Level 3, 20 Alfred Street, MILSONS POINT NSW 2061

(56) Related Art
WO 98/06927
DE 3206033
SU 481748



INTERNATIONAL APPLICATION PUBLISHED UNDER THE PATENT COOPERATION TREATY (PCT)

<p>(51) International Patent Classification ⁷ : F16L 55/40</p>	<p>A1</p>	<p>(11) International Publication Number: WO 00/57100 (43) International Publication Date: 28 September 2000 (28.09.00)</p>
<p>(21) International Application Number: PCT/NO00/00104 (22) International Filing Date: 22 March 2000 (22.03.00) (30) Priority Data: 19991368 22 March 1999 (22.03.99) NO (71) Applicant (for all designated States except US): AATECHNOLOGY [NO/NO]; Fanaveien 13 B, N-5222 Nesttun (NO). (72) Inventor; and (75) Inventor/Applicant (for US only): AADLAND, Harald [NO/NO]; Lundhaugveien 9, N-5221 Nesttun (NO). (74) Agent: AS BERGEN PATENTKONTOR; C. Sundtsgt. 36, N-5004 Bergen (NO).</p>		<p>(81) Designated States: AE, AG, AL, AM, AT, AU, AZ, BA, BB, BG, BR, BY, CA, CH, CN, CR, CU, CZ, DE, DK, DM, DZ, EE, ES, FI, GB, GD, GE, GH, GM, HR, HU, ID, IL, IN, IS, JP, KE, KG, KP, KR, KZ, LC, LK, LR, LS, LT, LU, LV, MA, MD, MG, MK, MN, MW, MX, NO, NZ, PL, PT, RO, RU, SD, SE, SG, SI, SK, SL, TJ, TM, TR, TT, TZ, UA, UG, US, UZ, VN, YU, ZA, ZW, ARIPO patent (GH, GM, KE, LS, MW, SD, SL, SZ, TZ, UG, ZW), Eurasian patent (AM, AZ, BY, KG, KZ, MD, RU, TJ, TM), European patent (AT, BE, CH, CY, DE, DK, ES, FI, FR, GB, GR, IE, IT, LU, MC, NL, PT, SE), OAPI patent (BF, BJ, CF, CG, CI, CM, GA, GN, GW, ML, MR, NE, SN, TD, TG).</p> <p>Published With international search report. Before the expiration of the time limit for amending the claims and to be republished in the event of the receipt of amendments. In English translation (filed in Norwegian).</p>
<p>(54) Title: APPARATUS FOR PROPULSION IN OBLONG CAVITIES</p>		
<p>(57) Abstract</p> <p>An apparatus for propulsion inside an oblong cavity, such as pipes or the like, is disclosed. The apparatus is characterized by comprising a central rotating part comprising an inclined wheel construction arranged to thrust towards the inner wall of the cavity, in that the central rotating part comprises a plurality of roller elements (1) arranged in a row against each other, and two adjacent roller elements (1) in the row comprise mutually adjacent inclined sliding faces (15), so that each element is arranged to be displaced in radial direction outward from a central shaft (11) due to axial compression of the unit of inclined roller elements, until the corresponding wheel construction abuts the inner wall of the cavity, and that the wheel construction includes that a bearing construction is arranged enclosing around each roller element, and being rotatably independent of its corresponding roller element, and is mounted at an inclined angle defining the climbing angle of the apparatus during propulsion, and further the apparatus comprises drive means for rotation of the rotatable part. It is an essential feature of the apparatus that it comprises internal rotational counter force, and that automatic transmission may be provided.</p>		

APPARATUS FOR PROPULSION IN OBLONG CAVITIES AND PIPES.

The present invention concerns an apparatus for propulsion
in oblong cavities and pipes; as stated in the preamble of
5 the following claim 1

By oblong cavities is meant pipes, ducts, drilled or mined
holes in rock, or wells which are drilled with or without
casing in the ground (oil related holes), in metals or
10 other materials.

According to the invention the apparatus is used when
inspection or different kind of work are performed in such
cavities. According to the invention the apparatus may be
15 used to force forward the equipment for boring the hole,
but can also be used for pulling equipment through the
cavity.

In such cavities, pipes and ducts, where it is not possible
20 to use people there is often need for inspection, service,
maintenance and other work to be done. It might also be
necessary to increase the propelling power on the drilling
equipment which is drilling holes/wells.

25 In vertical holes, for example in oil related wells, it is
normal to pull the necessary equipment down into the well
by means of gravity, if it is not pushed downward by means
of a pipe. In horizontal holes or pipes where it is not
possible to utilize gravity, an apparatus for pulling or

pushing is required for the equipment to be transported. Different hydraulic methods to pump forward equipment have also been tested. The methods which are based on pipes for transporting the equipment, require a lot of space and
5 personnel to run it all day and night, and further the transportation speed is relatively low.

From British patent GB-1.328.886 a vehicle coupled to a coiled tubing is known, thus enabling the vehicle to pull
10 or push the coiled tubing.

From British patent GB-2.196.715 a device which is driven forward by liquid or gas pressure through a pipeline is known.

15

From GB-2.200.970 a vehicle having motor powered wheels is known, but where propulsion may be provided also by means of chain and sprocket wheels.

20 From U.S. patent 4.941.511 a joint separated vehicle is known, where one part includes the energy source and the other part includes a motor connected to the driving wheels. A similar device is known from GB patent specification 2.122.713.

25

From EP patent specification 0.461.964 a vehicle where propulsion is generated by means of motor driven belts or wheels is known.

30 In DE patent specification 3.206.033 there is shown a vehicle where the propulsion is provided by means of an obliqued wheel, the wheel axis of which is mounted eccentric on an shaft which is positioned centric of the vehicle. The wheel is therefore aligned mainly crosswise to
35 the traction direction. Said eccentricity causes the wheel to be in contact with the pipe wall and the contact point moves as the shaft is rotated. The oblique position of the wheel causes that the movement of the contact point also

AMENDED SHEET

AMENDED SHEET

generates propulsion. Further the vehicle is also equipped with radial directed wheels which abut the pipe wall for centring the vehicle inside the pipe line. Further the vehicle is equipped with radial directed wheels which abut
5 the pipe wall for centering the vehicle inside the pipe, and for giving counter-torque to the drive motor.

From SU patent 481 784 a vehicle is known where several crosswise spring loaded wheels are mounted adjacent the
10 surface of the vehicle so that the wheels abut the pipe wall and centers the vehicle within the pipe line. When the vehicle rotates around it's own axis, the wheels cause a propulsion corresponding to the wheel angle. This apparatus need counter force torque.

15

From Norwegian Patent No. 178.276 a pipe tractor arranged to move within canals and pipes is known, in that the end portions of the tractor is mounted and equipped with spring loaded arms to which crosswise wheels are mounted, and the
20 wheels abut the inner surface of the pipe, so that side force affecting the wheels provides for propulsion of the vehicle when the end portions are rotating. The end portions rotate in opposite directions related to each other, and one of the ends acts as counter torque for the
25 other end, and visa versa.

From International patent PCT/GB93/0111 a down hole tool is known, for providing rotary support of a downhole assembly in which the tool is incorporated. The tool also converts
30 rotary contact with the wellbore into a longitudinal force which turns the assembly along the wellbore. The tool comprises a stabiliser including rollers, wherein the roller axis are skewed to be tangential to a notional helix, such that the natural path of roller contact with
35 the wellbore has a longitudinal component in addition to the usual circumferential path. The tool can be used on drill strings and in downhole assemblies with motor. The

AMENDED SHEET

AMENDED SHEET

tool may also pull a cable supplying the tool with electricity/hydraulic power for the propulsion machinery.

5 The pulling-/pushing apparatus of today are encumbered with a lot of disadvantages. Firstly they are very complex, they have a limited operation range and they are produced for dedicated actions/tasks which they are intended to execute. There are also strict requirements regarding the surroundings in which they are used.

10

It is an object of the invention to prepare a new and improved propulsion apparatus for transporting (pushing/pulling) through pipes/cavities.

15 Further it is an object to produce an apparatus which may effect an increased pulling power, independent of the design of the cavity, and reduced demands to the strength/toughness of the inside wall of the pipe/cavity.

20 A further object is to produce an apparatus that can work without any counter torque. Finally it is an object to produce a shorter propulsion apparatus with lower weight, therefore being easier to handle, and may carry more equipment for each trip.

25

The apparatus of the present invention is characterized by the features which are defined in the characterizing clause of the following claim 1.

30 The preferred embodiments of the apparatus in accordance to the invention are stated in dependent patent claims.

35 With this invention an apparatus with a simple construction is designed, and which is easy to run and covers a large working area, and more specific the apparatus may operate in ducts having very variable cross section and variable diameter, that is to say within the working range of the apparatus within the maximum and minimum diameters for its

AMENDED SHEET

AMENDED SHEET

operation. The apparatus involves a simple design so that different sizes of it may pull/push i holes having diameter ranges of millimetre to several meters.

5 The apparatus is further designed for automatic adjustment of the pulling force, independent of the design of the cavity. This occur when the traction roller (the sliding element), against the action of spring force, changes its orientation from its maximum angle position relative to the
10 longitudinal axis of the apparatus, and to the position where it is perpendicular to the longitudinal axis. Then the apparatus rotates with the wheels running so the propulsion of the apparatus becomes zero. Thus if the mass of the tool to be pulled and/or be pushed becomes too
15 large, one avoids the apparatus being exposed to overload. The contact point of the traction roller towards the pipe wall moves in a non-slipping revolving movement around the pipe wall.

20 It has no consequences either the cavity is angular or round, and the diameter may be changed continuously as long as it stays within the maximum/minimum operation diameter of the apparatus. In contrary to the previously known traction mechanisms, which require uniform holes, this
25 apparatus can go into any kind of holes.

The device according to the invention, does no need any counter torque, due to the fact that its motor rotational torque has internally counter force within the device.

30 The apparatus may generate high push-/pull forces, it can operate in varying diameters, cope with varying hole geometries, it can automatically vary speed and pull-/push force with regard to the load, and is gentle to the inside
35 wall of the cavity.

The apparatus has a simple construction since it consists of a number roller elements each having similar design,

AMENDED SHEET

AMENDED SHEET

they may be single standing or involve several mounted one after another.

The individual elements may be mutually displaced relative to each other, and perpendicular to the travel direction/longitudinal axis of the apparatus. The roller elements mounted in one assembly will rotate at the same speed.

10 The apparatus according to the present invention will now be described more detailed in the following, with reference to the accompanying schematic drawing, and wherein:-

Figure 1 shows a complete propulsion apparatus able to move inside a cavity/pipe. The rotational direction of the roller elements is also shown.

Figure 2 shows in three different sections an example of the construction of a roller element, and where the inclined surfaces of roller element is shown, and a sliding element (a bearing, such as a ball bearing) where the outer part may rotate around the peripheral surface of the roller element.

25 A plurality of roller elements mounted one after another is shown on Figure 3. The roller elements are drawn in section inside a pipe shaped cavity. The arrows show the compression of the roller elements which makes them forced outwardly towards the inner wall of the cavity.

30 Figure 4 shows the same as figure 3, but includes in addition the central shaft extending through the assembly. The figure also shows the internal oblong radial extending slot, the extension of which defines defines how far a rolling element can be radially displaced with respect to the shaft.

AMENDED SHEET

AMENDED SHEET

On figure 5 is the roller elements seen from i front when the apparatus includes five or more roller elements mounted one after another. The roller elements are mounted have a mutually displacement of 72° (degrees).

5

The movement of the apparatus as seen from the side on moving forward is shown on Figure 6.

Figure 7 shows the anchoring of the roller element including a spring construction.

10

Figure 8 shows an example in practical use for the apparatus of the invention

Introductory the reference is to the figures 1-2. Figure 1 shows a complete apparatus for propulsion in a cavity 13, for instance inside a formation of rock ground.

15

The apparatus includes a plurality of roller elements 1 which are arranged on line against each other. Each roller element 1 has initially a cylindrical shape where each plane end surface are cut off to establish inclined sliding surfaces 15 with respect to the plane radial surface, as clearly shown on figure 2. In the sliding direction the surfaces of two adjacent surfaces comprises mutually corresponding tongue and groove like guiding means for defining the sliding direction of the roller elements as they are compressed axially and thus slide radial away from each other, defined by the angle between the surfaces (see below).

20

25

30

The two facing inclined plane surfaces of two adjacent roller elements, which are positioned against each other, must have the same angle to the longitudinal axis X through the element. This angle is in the range of $0-90^\circ$.

35

When the elements 1 are arranged against each other and having the inclined surfaces mutually towards each other in

AMENDED SHEET

AMENDED SHEET

axial direction, and when this assembly is exposed to axial compression the elements 1 will slide in radial direction. The mutually inclined surfaces 15 on two neighbouring elements 1 then will slide along each other in a way so
5 that they slide in radial outward direction.

In accordance to a preferred embodiment, the sliding surfaces of two adjacent roller elements may have a shape so that the elements mutually displaces 180° in opposite
10 directions. Then the central shaft will not be exposed to strain. But however, any internal angle may be chosen.

As shown in figure 2, each roller element includes a slot 30 extending through the whole element in axial direction. The slot extends in radial direction from the central shaft
15 32 and a distance towards the outer wall 33 of the element. Alternatively the slot may be completely open and penetrate the wall 33. The slot 32 is of such dimension that the element may be treaded onto the central through extending
20 shaft 11, and it can be displaced in radial direction outwards and inwards on the shaft limited of the outer extensions of the slot. The central shaft 11 extends through all elements 1.

25 When the roller elements are axially compressed, the inclined cut sliding surfaces 15 cause the roller elements to press towards the wall of the cavity in which they are operating. When the apparatus «drives» forward in a cavity, the roller elements 1 at the back will push on the roller
30 elements further forward in the assembly, thus causing also they being pressed outwardly towards the inner wall 13 of the cavity. This pressing force increases with the power of which the propulsion apparatus must add to the equipment it moves/transfers. As indicated in figure 1 the set of
35 propulsion segments mounted between the motor section 6 and an equipment section 5 (including an equipment section 10) on the other end of the shaft. These sections 6 and 5/10

AMENDED SHEET

AMENDED SHEET

15-05-2001

9

are used for generating the necessary axial compression of the roller elements so they are pressed radial outward.

With reference to figure 2, each roller elements 1 is surrounded by a ring shaped circular sliding element 4 which slides relative to the roller element 1. A ball bearing 2 comprises a stator part 40 which is mounted recessed in a seat in the circular outer surface of the roller element. Thus the sliding element 4 represents a circular shaped rotor part rotating on the outside of the stator 40 via said ball bearing 2.

The sliding element 4 is mounted in such way that it forms an angle to the longitudinal axis X through the roller element. This angle defines the climbing angle (the pitch) of the apparatus during the propulsion, i.e. it decide how fast the apparatus screw itself through the cavity.

All roller elements are produced in a manner so that the stator- and rotor part of the sliding element defines the same (not perpendicular) angle with respect to said central axis X.

In the preferred embodiment where two produced roller elements are mounted facing each other having their slots extending respective 180° in opposite direction, the two sliding elements, viewing the apparatus from one side, face mutually in opposite direction. Since the elements are displaced radially 180° in opposite direction, the diametrical opposite points of the respective rotor parts 4 will establish abutment against the inner wall of the cavity.

When the apparatus, consisting of a number of identical roller elements, are forced together in axial direction, the roller elements will be forced radial outwards in given directions until an point on the bearing-rotor parts form contact towards the cavity inner wall.

AMENDED SHEET

AMENDED SHEET

Empf.zeit:15/05/2001 16:08

Empf. nr.: 051 D 010

An assembly of roller elements including a given angle between the sliding surfaces is shown on figure 1. The sliding surfaces are designed in such a way that the two first roller elements, seen from the left, are pushed substantially one way (upwards on the figure), while the two next roller elements move in the opposite direction (downwards the figure). Thus the apparatus is centred, that is to say it covers the complete circumference, $72^\circ \times 5 = 360^\circ$. To gain such a balance the sum of the mutual displacements between the elements must be 360° . Thus a roller element is turned/displaced a given number of degrees around the shaft 11 with respect to its facing neighbouring roller element, so that the sum of the angle offsets for all elements in the row is said 360° .

When five roller elements are mounted in the row, there is an offset angle of 72° between each roller elements so that the sum of the angle offsets is 360° .

Figure 1 also shows a motor 6 which by means of a transmission 7 transfers rotational force to the roller elements 1 and rotational counter torque to the outer part of the sliding element 4. The rotational force acts between stator 40 and rotor part of the sliding element 4. The fact that the rotational force operates between the inner and outer part of the sliding element, effects that the rotational torque between the stator and rotor of the motor equalises in the sliding element, and thus the motor has counter torque. If the motor is reversed, the apparatus will move in the opposite direction. The roller elements will normally be rotational fixed to each other simultaneously as they have a degree of freedom from the centre of assembly and outwards to periphery, thus it is sufficient, for effecting the complete assembly of roller elements to rotate, to supply motor force to the roller element being closest to the motor 6 and transmission 7. When the motor is running the apparatus shown in figure 1,

AMENDED SHEET

AMENDED SHEET

15-05-2001

11

exhibits a buckling forward movement, and it buckles in all sections simultaneously. The outer part of the sliding segment establishes point by point contact with the inner wall of the cavity and effects an axial directed force so that the apparatus moves forward in desired direction.

When propulsing in a cavity 13 where the diameters are within the minimum and maximum diameters of the propulsion apparatus, all propulsion segments 1 with wear shoes 4a on the outer part of the circular sliding elements or the like, are always contacting the cavity wall. If the assembly includes a separate motor 6 and transmission 7 as shown on the figure, it will it move forward without being rotationally coupled to the central shaft 11. It will then have pulling force at the rear end 8 and pushing force in the front end 10 at the same time as the roller elements 1 are forced outwards. The design of the propulsion apparatus establish an outside helical shaped channel on the outside of the apparatus, wherein fluid such as liquid can flow through. Fluid can also flow through the central shaft.

As noted it is the mounting of sliding elements on the roller elements that makes the propulsion apparatus move forward when the roller elements rotate about their own axis. The sliding segments are mounted in such way that they it have an inclined angle on that side of the roller element which is forced towards the wall of the cavity 13. The inclined angle of the sliding element 4 represents the angle by which the rotor part (with external wear shoe) of the sliding element is rolling against the inner wall of the cavity.

According to a preferred embodiment the design of the sliding element may comprise a spring mechanism which is able to displace the sliding element so that the elements angle changes from a maximum angle to a position being perpendicular to the axis. This mechanism is shown in the figures 7A-C.

AMENDED SHEET

AMENDED SHEET

Empf.zeit:15/05/2001 16:08

Empf. nr. 0051 D 015

Figure 7 shows the rotor element 4 mounted in its seat surrounding the the roller element 1. In its inclined position the rotor element 4 is clamped by means of a
5 spring construction 50 made of a number of circular and/or wave shaped leaf springs (or for example a coil spring) which is also surrounding the roller element. When the load to be pulled/pushed by the apparatus gradually increases, as indicated with arrows F on the figures 7, also the
10 «pull» of the attaching point or surface of rotor part towards the inner wall of the cavity increase. The rotor part will then pivot towards its zero position, where the apparatus rotates only without any propulsion. Just before the apparatus comes to a stand-still the apparatus effects
15 its greatest pulling capability but exhibits its smallest climbing angle/velocity. It can be said that the apparatus continuously changes transmission downward from its maximum climbing angle to its minimum (zero) climbing angle.

20 Thus the tractive power increases when the spring is compressed so that the previous mentioned climbing angle reduces, the propulsion apparatus will slow down speed and the tractive power increases. If the tractive power is large enough the mentioned angle will be reduced towards
25 zero degrees climbing angle (i.e. perpendicular to the axis), and the propulsion apparatus will be at stand still and push with a constant power. A climbing angle of zero degrees for the rotor part of the sliding element occurs
30 when it is perpendicular to the central shaft 11, and it will look like the rotor part 4 of the sliding element rotates (non slipping) around a shaft without any climbing angle. A possible outer skin or membrane (figure 1) can preferably be fixed i.e. in a slot between the inner and
35 outer part (wear shoe 4a) of the sliding elements. Then only the outer wear part will be visible from outside.

Figure 3 shows a plurality of roller elements 1 mounted one after another in an oblong cavity 13. The figure shows how

AMENDED SHEET

AMENDED SHEET

the roller elements 1 presses each other axially and how this pushes all the roller elements 1 outward towards the inner wall of the cavity 13.

5 Fig.4 shows mainly the same as fig.3, but this figure shows the central shaft 11. The figure shows that the central shaft is rotationally dis-coupled from the roller elements 1. The figure also shows the restrictions with regards to the maximum and minimum diameter when a straight shaft is
10 conducted through the propulsion apparatus. The roller element 1 can move as far from the centre position around the central shaft 11 as the oblong hole in the roller element 1 permits.

15 The propulsion apparatus can also be produced without any straight central shaft 11, and then the maximum/minimum diameter of propulsion apparatus may have another ratio.

Figure 5 shows a front view of the propulsion apparatus
20 (section A-A on figure 1).

The figure shows that all the roller elements 1 are in contact simultaneously and that a helical shaped channel establishes on the outside of the propulsion apparatus in
25 such way that fluid may pass by outside of the propulsion apparatus.

Figure 6 shows the movement of the propulsion apparatus as seen from the side when moving/winding forward.
30

The figure shows a solution where roller elements are mutually connected with a membrane 3, such as rubber, or a metal membrane having a so-called accordion shape. The membrane may be threaded over the complete construction and
35 is attached to the rotor element at each of the roller elements and to the outer shield of the motor. Then the motor will rotate the roller elements and said outer parts will move in the mentioned winding forward movement.

AMENDED SHEET

AMENDED SHEET

If roller elements of the apparatus is not engaged towards the inner wall of a cavity, then without said membrane the apparatus will lie still. But with a membrane, as
5 mentioned, the apparatus will wind in a forward direction, even if it is lying on a plane surface, because the roller elements are rotationally mutually connected.

The uppermost figure shows a cut through section without
10 roller elements. The arrows show the direction of movement of the different elements in the assembly. The big arrow shows the forward travelling direction to the apparatus.

The figure at the bottom shows the same as the uppermost
15 figure, but here the propulsion apparatus is seen from the outside. The wear shoe 4a of the sliding elements 4 and the membrane 3 is shown. When the membrane 3 is used in this assembly the outer parts of the sliding elements 4 are mutually rotatably connected.

20 By the way, if the sliding element has its own motor drive, the inner driving unit will rotate and push the conical parts so that point of contact of the outer ring against the wall of the cavity moves forward in a helical shape.

25 The membrane will also protect the sliding elements 4 from influence of dirt and particles as well as the sliding elements can be surrounded by oil for lubrication and for cooling.

30 Figure 8 shows a possible way of using this propulsion apparatus when drilling holes in rock formations to for instance a water reservoir. This propulsion apparatus can be produced in all sizes, and used for operation in all
35 oblong cavities where tasks that require propulsion are to be effected.

AMENDED SHEET

AMENDED SHEET

The invention shall not be restricted by the examples of its embodiment specified above, in that many variations are possible within the range of the idea of the invention as defined in the claims.

AMENDED SHEET

AMENDED SHEET

Empf.zeit: 15/05/2001 16:10

Empf nr : 051 P 019

P A T E N T C L A I M S

1. An apparatus for propulsion inside a cavity, such as
5 pipes or the like, comprising a central inclined rotatable
wheel construction arranged to thrust towards the inner
wall of the cavity, characterized in that

the central rotatable wheel construction comprises a
plurality of roller elements (1) arranged in a row, one
10 against another, and each roller element (1) includes a
sliding element (4) arranged enclosing around each roller
element (1), and being able to rotate independent of its
corresponding roller element (1), and is mounted at an
inclined angle defining the climbing angle of the apparatus
15 during its propulsion,

two adjacent roller elements (1) in the row comprise
mutually adjacent inclined sliding faces (15), so that
each element on axial compression of the unit of inclined
roller elements (1), is arranged to be displaced in radial
20 direction outwardly from a central shaft (11), until the
the sliding element (4) abuts the inner wall of the cavity,
and

the apparatus comprising a drive means for rotation of
the rotatable part.

25

2. Apparatus in accordance to claim 1,
characterized in that the inclined surfaces (15) of two
adjacent roller elements (1), which are positioned against
each other, mutually have the same angle to the
30 longitudinal axis X through the element, in that the angle
is in the range of 0-90°.

3. Apparatus in accordance to claim 1,
characterized in that the surfaces of two adjacent surfaces
35 (15) in the sliding direction, comprise mutually tongue and
groove like guiding means for defining the sliding
direction of the roller elements (1) as they are compressed
axially and thus slide radial away from each other.

AMENDED SHEET

AMENDED SHEET

4. Apparatus in accordance to claim 1,
characterized in that each roller element (1) includes a
slot (30) extending in axial direction through the element
5 (1), and extending in radial direction from a central axis
(32) and a distance outward towards the outer wall (33) of
the element, and preferably, the slot (30) penetrates the
wall (33), in that the slot (30) is of such dimension that
the element may be treaded onto the central shaft (11)
10 extending through the sliding element (1), and it may be
displaced in radial direction outwards and inwards on the
shaft (11) limited of the outer extensions of the slot
(30), and the shaft (11) extends through all elements (1).
- 15 5. Apparatus according to any of the preceding claims,
characterized in that a roller element (1) is mounted
pivoted-displaced a given number of degrees around the
shaft (11) relative to its adjacent element, so that all
the elements (1) in the row centre the apparatus.
- 20 6. Apparatus according to any of the preceding claims,
characterized in that five roller elements (1) are mounted
in the row, there is an offset angle of 72° between each
roller element, so that the sum of the angle offsets is
25 360° for all elements (1) in the row.
7. Apparatus according to any of the preceding claims,
characterized in that the bearing is mounted in a seat
designed in the surface of the roller element (1).
- 30 8. Apparatus according to any of the preceding claims,
characterized in that the sliding element (4) in its
inclined position is clamped by means of a spring
construction (50) prepared of a number of circular and/or
35 wave shaped leaf springs, or a coil spring, also
surrounding the roller element.

AMENDED SHEET

AMENDED SHEET

9. Apparatus according to any of the preceding claims, characterized in that the sliding element (4) is arranged to, against the action of spring force (50), to be displaced from its inclined position (Fig. 7A) at to the
5 position where the roller element is perpendicular to the shaft (11) (Fig. 7C).

10. Apparatus according to claim 9, characterized in that the apparatus is arranged to continuously change its
10 transmission downward from its maximum climbing angle to its minimum (zero) climbing angle, due to the course stated in claim 9, that is to say there is provided increased power and lower propulsion speed, gradually changing from reduced power and higher propulsion speed.

15

11. Apparatus according to any of the preceding claims, characterized in that the sliding elements (4) are mutually joined by a connecting element (figure 6), such as an elastic membrane (3), such as rubber, or a metal membrane
20 with the shape of a so-called accordion.

12. Apparatus according to any of the preceding claims, characterized in that the connecting element (3) is connected to the sliding element of each roller element,
25 and with the outer cover of the motor part, simultaneously as the drive means rotates the row of roller elements.

13. Apparatus according to any of the preceding claims, characterized in that roller elements (1) are designed so
30 that the elements mutually displaces mainly ca 180° in opposite directions.

14. Apparatus according to any of the preceding claims, characterized in that the drive means (6) is arranged to
35 rotate the roller element assembly and/or the outer part of the bearing construction (40).

AMENDED SHEET

AMENDED SHEET

15. Apparatus according to any of the preceding claims, characterized in that the propulsion apparatus is independent of rotation counter torque.

16. Apparatus according to any of the preceding claims, characterized in that the propulsion apparatus reverses when the direction of rotation reverses.

17. An apparatus for propulsion inside a cavity, such as pipes or the like, said apparatus being substantially as herein described with reference to the drawings.

18. A method of propelling an apparatus through a substantially tubular cavity, said method being substantially as herein described with reference to the drawings.

Dated this 24th day of September 2003.

AATECHNOLOGY AS

BY:

HODGKINSON AND McINNES

Patent Attorneys for the Applicant

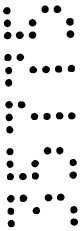

FIGURE 1

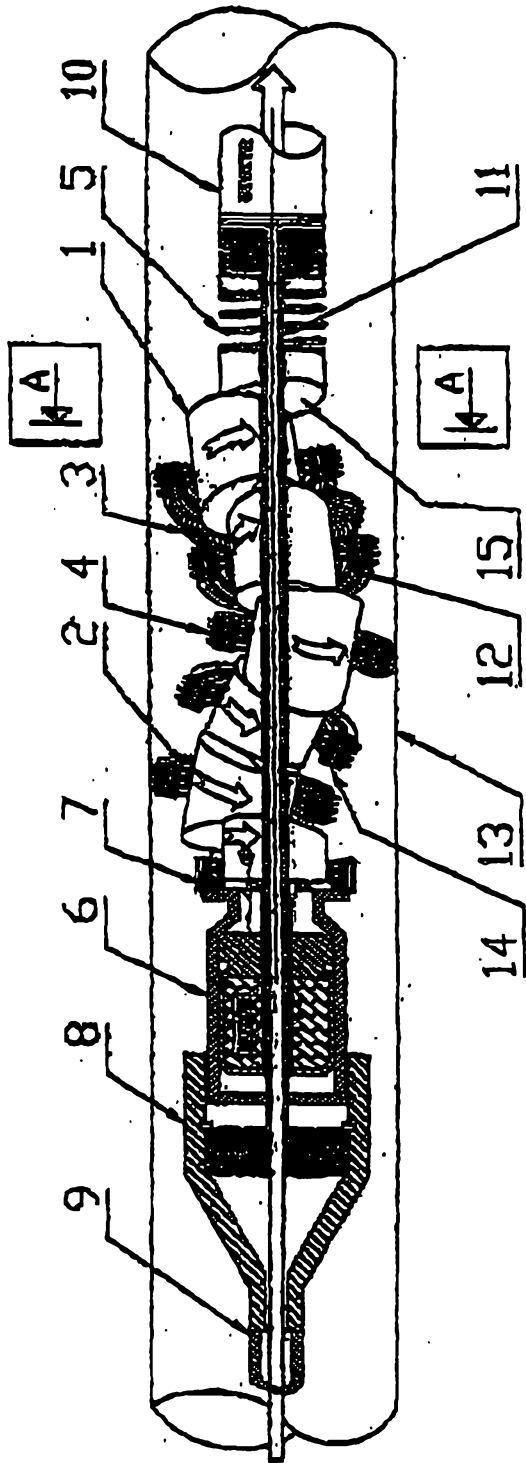
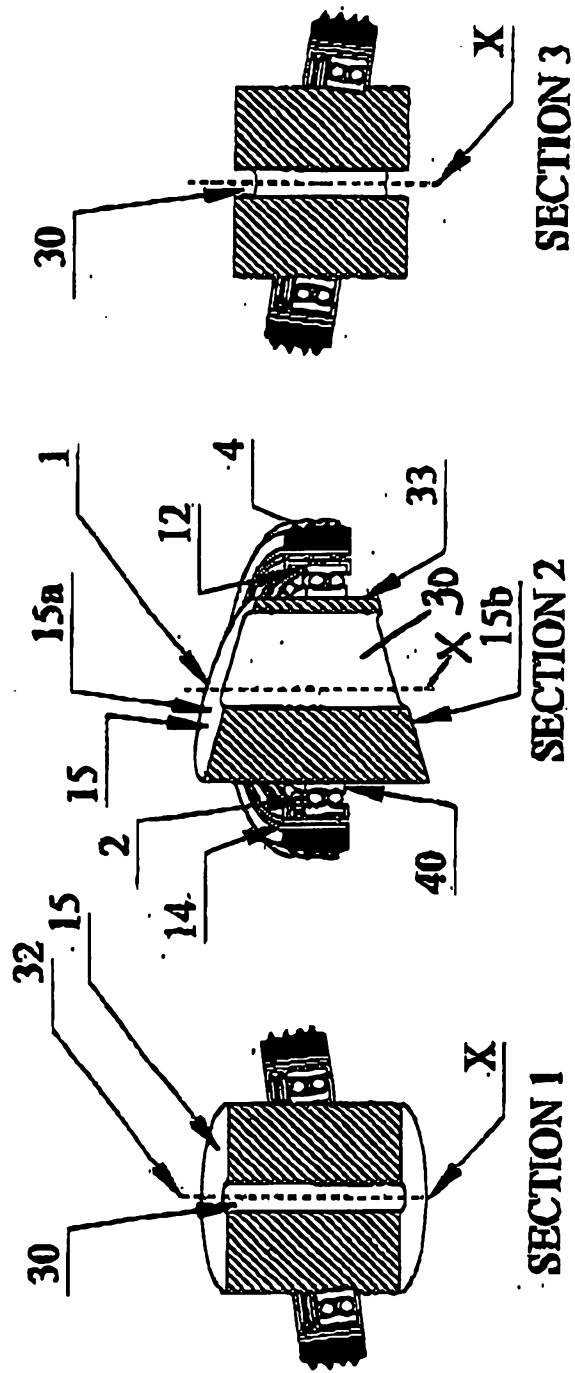

FIGURE 2



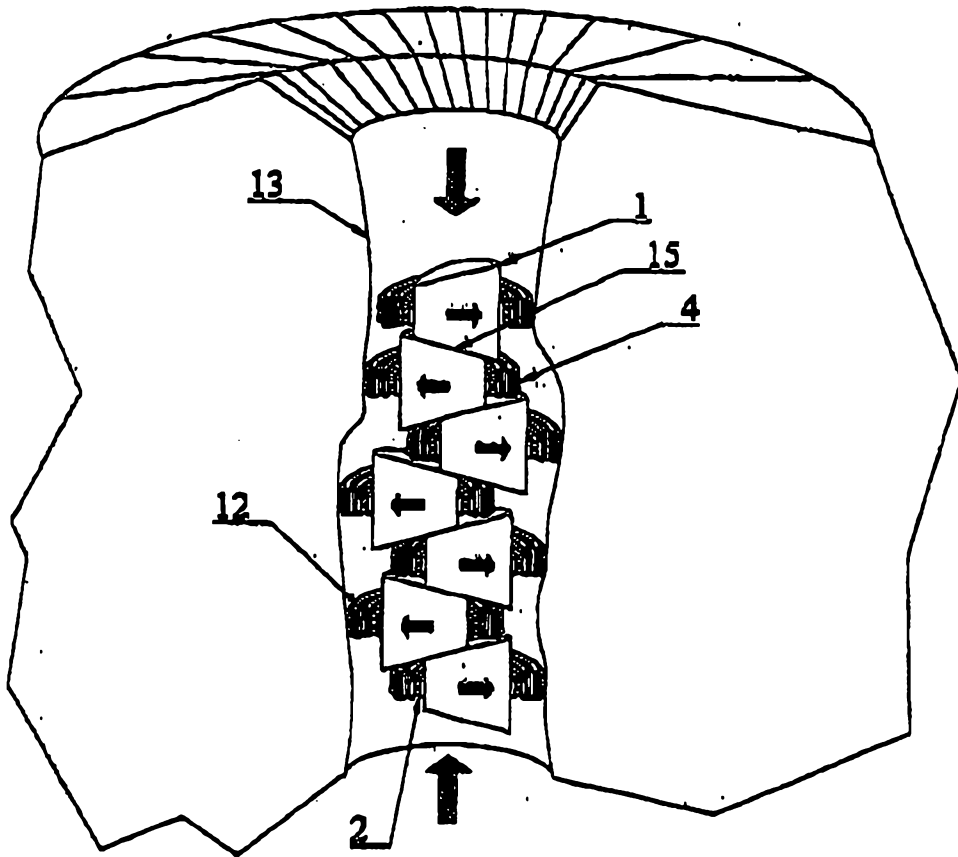

FIGURE 3

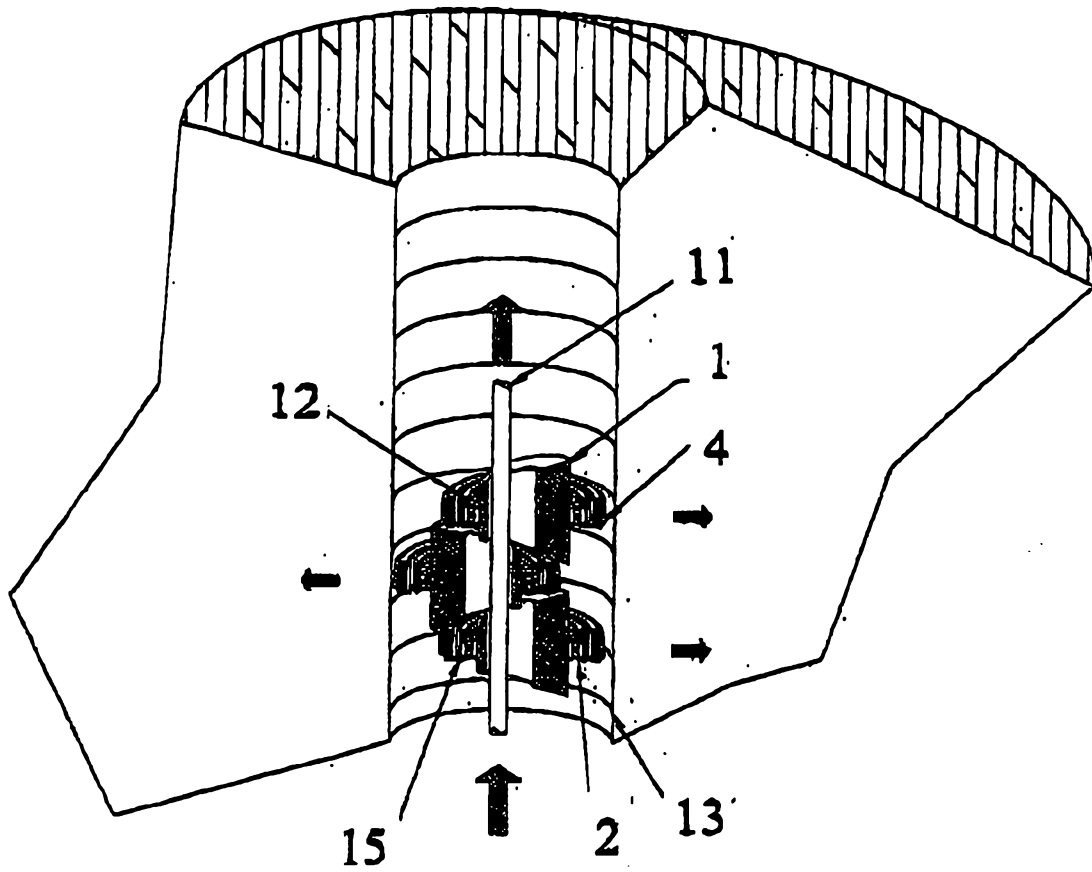

FIGURE 4

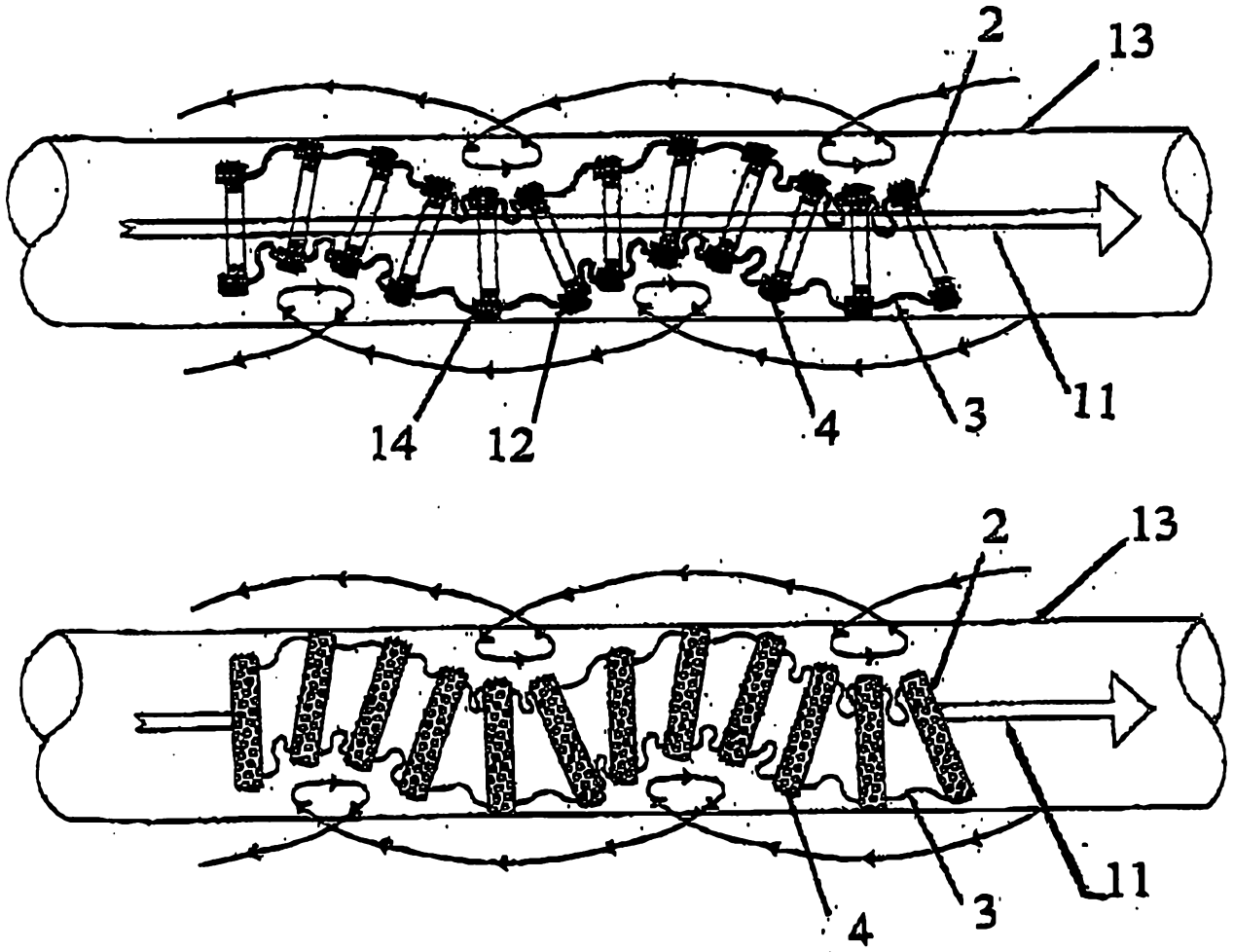

FIGURE 6

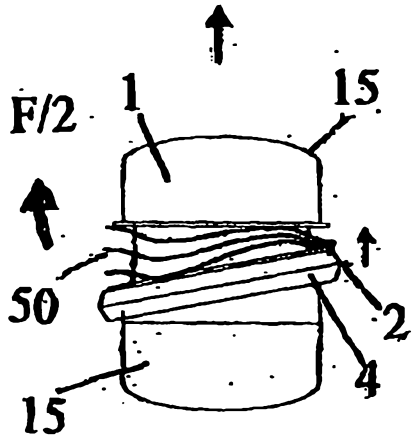

FIGURE 7A

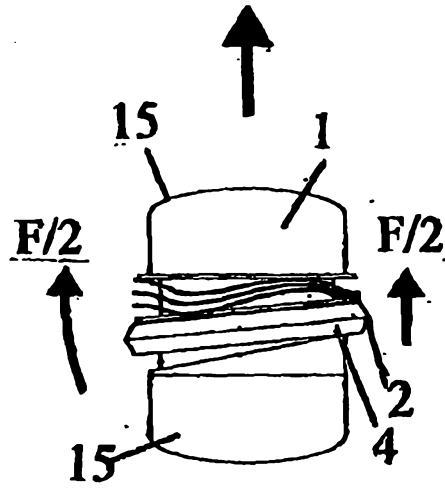

FIGURE 7B

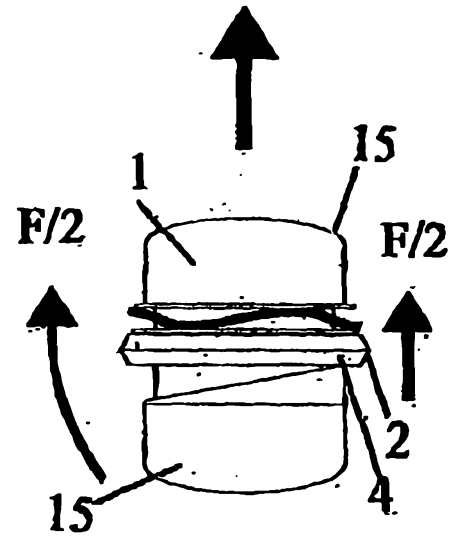

FIGURE 7C

**DRILLING OF HOLES IN ROCK FOR
HYDRO ELECTRIC POWER STATION**

- 1. DRILL BIT.
- 2. HYDRAULIC MOTOR.
- 3. PROPULSION APPARATUS.
- 4. DIRECTIONAL TOOL.
- 5. PIPE OR HOSE.
- 6. HYDRAULIC GENERATOR
- 7. WATER RESERVOAR.
- 8. HOSE/PIPE FOR SUPPLY OF WATER.
- 9. DRUM WITH HOSE OR PIPE.
- 10. ROCK.

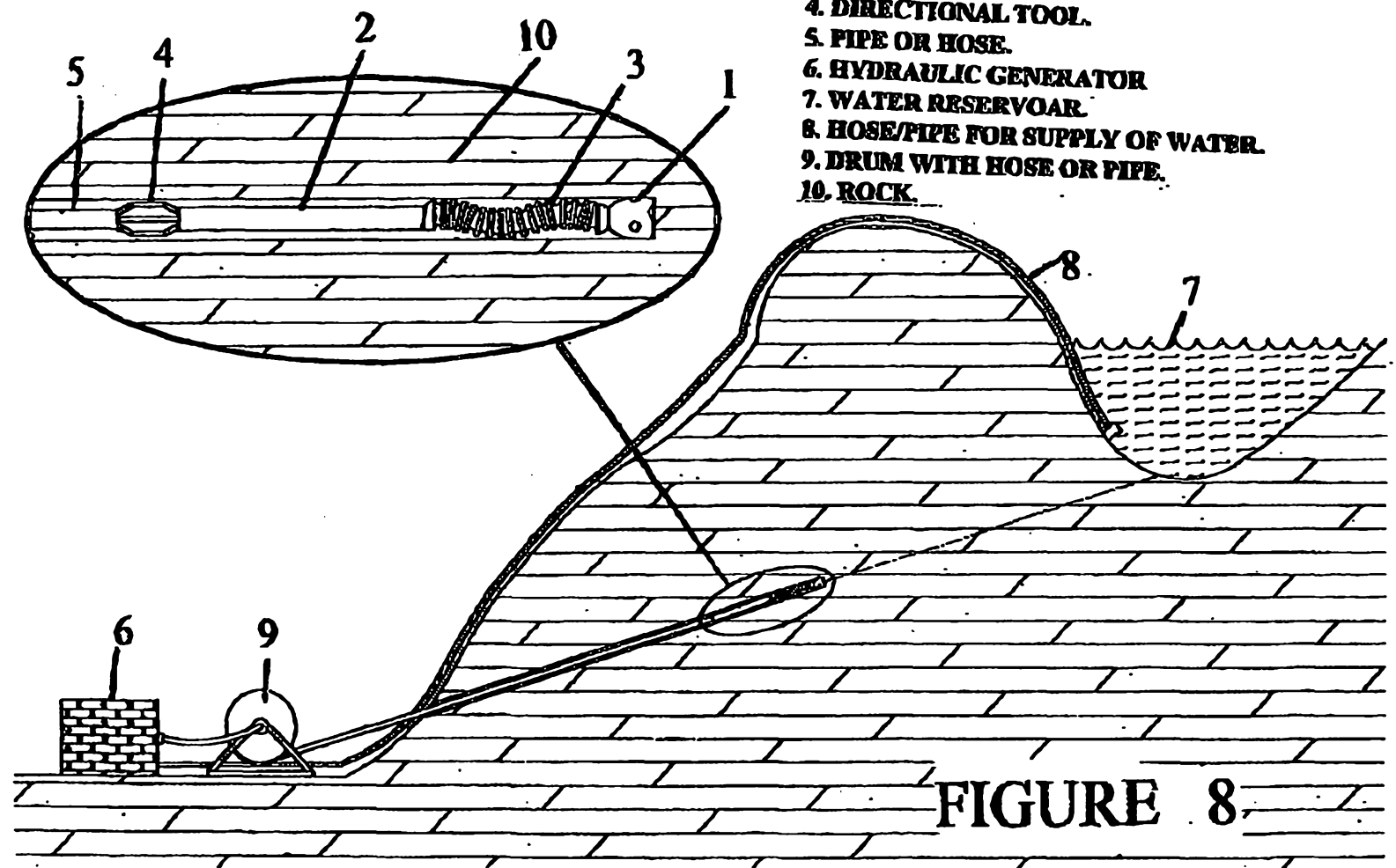

FIGURE 8.