

(19) **DANMARK**

(10) **DK/EP 2933542 T3**



Patent- og
Varemærkestyrelsen

(12) **Oversættelse af
europæisk patentskrift**

-
- (51) Int.Cl.: **F 16 L 25/00 (2006.01)** **F 16 L 33/26 (2006.01)**
- (45) Oversættelsen bekendtgjort den: **2018-08-27**
- (80) Dato for Den Europæiske Patentmyndigheds bekendtgørelse om meddelelse af patentet: **2018-05-16**
- (86) Europæisk ansøgning nr.: **15401015.1**
- (86) Europæisk indleveringsdag: **2015-03-04**
- (87) Den europæiske ansøgnings publiceringsdag: **2015-10-21**
- (30) Prioritet: **2014-04-17 DE 102014105555**
- (84) Designerede stater: **AL AT BE BG CH CY CZ DE DK EE ES FI FR GB GR HR HU IE IS IT LI LT LU LV MC MK MT NL NO PL PT RO RS SE SI SK SM TR**
- (73) Patenthaver: **Brugg Rohr AG Holding, Industriestrasse 21, 5200 Brugg, Schweiz**
- (72) Opfinder: **Homann, Jörn, Groß-Buchholzer Straße 12, 30655 Hannover, Tyskland**
Nielinger, Helga, Max-Planck-Straße 106, 31535 Neustadt, Tyskland
Post, Marc, Über der Beeke 1, 31867 Hülsede, Tyskland
- (74) Fuldmægtig i Danmark: **RWS Group, Europa House, Chiltern Park, Chiltern Hill, Chalfont St Peter, Bucks SL9 9FG, Storbritannien**
- (54) Benævnelse: **TILSLUTNINGSFORBINDELSE FOR BØLGERØR**
- (56) Fremdragne publikationer:
EP-A1- 0 775 865
DE-A1- 10 245 979
DE-A1- 10 300 417
DE-U1-202005 001 018
SU-A1- 896 309

DESCRIPTION

The invention relates to a coupling connection for corrugated pipes as a fluid line having a coupling element, a supporting ring which can be applied in a form-fitting manner against an inner wall surface of the corrugated pipe, a first ring element which can be axially immovably secured to a circumferential surface of the corrugated pipe, wherein a portion of the corrugated pipe is enclosed between the supporting ring and the first ring element and can be secured in an axially immovable manner, and wherein an annular sealing chamber, which is circumferentially enclosed in a transition region between the supporting ring and the corrugated pipe, receives a sealing element which is loaded by a deformation force in a functional position which can be fixed by a fixing element, wherein a second ring element, which circumferentially encloses the coupling element and can be applied circumferentially with respect thereto and is translationally movable, wherein the first ring element and the second ring element are arranged coaxially to one another, with the result that an outer circumferential surface of the one ring element bears in a contact region against an inner circumferential surface of the other ring element, and the ring elements are movable translationally relative to one another along a sliding guide formed by the contact region, wherein the sealing element can be compressed in the sealing chamber by the relative translational movement of the ring elements, and the relative position of the ring elements that corresponds to this functional position can be fixed by the fixing element, and wherein the supporting ring is connected in one piece to the coupling element.

A coupling connection of the generic kind is known for example from EP 0 775 865 B1, which relates to an arrangement for connecting a corrugated pipe to a coupling element. The coupling connection has a supporting ring which can be screwed into the corrugated pipe, whose end protrudes from the corrugated pipe. A ring element designed as a pressing ring is

screwed onto the corrugated pipe far enough so that the end of the corrugated pipe protrudes. The coupling element forms with the pressing ring a sealing chamber, in which a graphite sealing ring is arranged. The sealing ring is deformed and compressed by axial tightening of pressure ring and coupling element against each other. Screw bolts are used for this, or a separate tool if no screw bolts are used. In this variant, the fixation of the compressed state is achieved in that the coupling element extends beyond the pressure ring and the protruding end is deformed. Alternatively, one or more pins as fixing elements can fix the pressure ring relative to the coupling element.

EP 1 457 726 B1 likewise relates to the fitting of such a coupling connection to a corrugated metal pipe, wherein a supporting ring is screwed spirally into the end of the metal pipe far enough so that a smooth-walled region with a smaller outer diameter than the clear width of the metal pipe both remains inside the metal pipe and extends beyond the end of the metal pipe, so that a coupling piece can be inserted between the metal pipe and the supporting ring. In this way, a sealing ring made of graphite and arranged on the circumference of the smooth-walled region of the supporting ring is deformed and pressed axially and radially between the coupling piece and the pressure ring. For this purpose, boreholes in the flange of the pressure ring of the coupling piece make it possible to bring the flanges closer to one another by means of screw bolts.

The drawback in the above-described coupling connections is primarily the high fabrication expense associated with the necessary small tolerance in the connecting region of the supporting ring with respect to the coupling piece. In particular, on the one hand the relative mobility must be ensured in order to be able to press the sealing ring into the sealing chamber, and on the other hand the fluid supplied by the corrugated pipe must be prevented from getting into the interior space of the sealing chamber in a reliable manner.

Of course, it has already been considered to make the supporting ring and the coupling piece as a single part, but in the case of the coupling connections this means abandoning the supporting ring, which in turn is required for the pressure ring and the reliable transmission of the forces occurring in operation.

Another kind of connection for corrugated metal pipes is described in DE 33 02 450 C2. A support bushing is screwed onto the end of a corrugated pipe and a pipe socket is screwed into the end of the corrugated pipe. The sealing occurs in that the clear width of the support bushing increases toward the end or the outer diameter of the pipe socket decreases toward the end. When the pipe socket is screwed into the corrugated pipe end, adapted by a shaping tool to the inner contour of the outer bushing, the corrugated pipe is sealed between the pipe socket and the support bushing.

A coupling fitting for corrugated pipes is known from DE 40 27 818 A1, having an outer bushing screwed onto the corrugated pipe end with a smooth pipe extension extending beyond the corrugated pipe end. The smooth pipe extension has an internal thread, into which a coupling pipe piece is screwed. The coupling pipe piece penetrates by a stepped end into the corrugated pipe. When screwing in the coupling pipe piece, the corrugation of the corrugated pipe is compressed at the end. The sealing occurs by a graphite sealing strip inserted into the last corrugation turns, which becomes deformed upon compressing the corrugation and is pressed against the inner wall of the outer bushing and the stepped end of the pipe socket that has penetrated into the corrugated pipe end.

From DE 33 41 297 C2 there is known a seal packing for the sealing of corrugated pipes, consisting of two bushings arranged on the corrugated pipe, which are able to move in relation to each other and engage into each other, between which an annular space encircling the corrugated pipe is

formed, said annular space being designed to hold a graphite sealing compound. There is provided a corrugated pipe sleeve, resting against the sealing region from the inside.

- 5 DE 20 2005 001 018 U1 relates to a connection between the end of a spirally corrugated metal pipe and a coupling piece. As alternative fixing means for the ring elements used, split rings are mentioned.
- 10 DE 103 00 417 A1 relates to a connection of conduit pipes consisting of two coaxial spirally corrugated metal pipes, wherein a conical ring is used as the second ring element.

Moreover, CH 589 249 A5 discloses rolling the end of a
15 corrugated metal pipe against the inner surface of a flange, wherein the corrugation is levelled out. The large pressure force occurring during the rolling produces between the formerly corrugated metal pipe and the metal flange a tight press fit. This kind of connection requires high equipment
20 expense at the installation site and requires thick-walled shaped pieces.

Starting from this prior art, the problem which the invention proposes to solve is to create a coupling connection which is
25 both easy to produce and reliable in operation, which can be installed without difficulty, and which reliably prevents the supplied fluid from getting into the sealing space and the flow of fluid inside the corrugated pipe from being impaired.

30 This problem is solved according to the invention by a coupling connection according to the features of Claim 1. The further embodiment of the invention can be found in the dependent claims.

35 According to the invention, in the coupling connection, in the functional position of the ring elements, a fixing element configured as a securing ring simultaneously engages in a form-fitting manner in a groove in the outer circumferential

surface of the first ring element and in a further groove in the inner circumferential surface of the second ring element, wherein the ring elements in the functional position are non-releasably connected by the fixing element, and in that the inner circumferential surface and/or the outer circumferential surface have/has a conical or dome-shaped portion by means of which the fixing element, as a result of the translational relative movement of the ring elements, is pressed into the groove of the first ring element counter to its elastic restoring force of the fixing element and projects automatically upon reaching the aligned position of the two grooves. Thus, with this configuration, by virtue of the displacement of the ring elements in relation to each other, there occurs either a compression or a widening of the fixing element, which upon reaching of the target position in the functional position produces an automatic form-fitting connection by undercutting in an annular groove. Neither an extra tool for the deforming of the fixing element nor an extra work step is required in this case. In this way, the ring elements are permanently connected in the functional position by the fixing element, in order to prevent their separation without damage. This configuration proves to be especially expedient particularly in the case of safety-relevant pipeline connections.

25

The supporting ring is connected to the coupling element as a single piece and the fixation of the corrugated pipe to the coupling connection and the seal is realized by the two ring elements. First of all, this eliminates a parting plane in the interior of the coupling element, which parting plane in the prior art on the one hand requires costly measures for sealing and on the other hand often involves a discontinuity relative to the conduit cross section, especially an abrupt change in the cross section, which results in flow and pressure losses. At the same time, according to the invention, neither is there a separate sealing off of the sealing chamber from the fluid flowing through the corrugated pipe, because the sealing is confined to the circumferential transition region of the

30
35

corrugated pipe at the supporting ring, which is especially easy to seal off. Yet the especially advantageous technical use of the coupling connection is explained not simply by the parting plane that is missing at the invention as compared to the prior art and the associated elimination of a sealing off. Rather, further particular benefits result from this. Namely, according to the invention, during the fixation of the coupling connection and the press fitting of the sealing element, the coupling element is not moved relative to the corrugated pipe, i.e., displaced axially. This eliminates the problem, occurring in the prior art, of the coupling piece being shortened after the press fitting of the seal. This shortening may lead to problems in the prior art primarily because the connection is not releasable, i.e., it can no longer be varied or adapted in its length. Instead, according to the invention, the sealing can also be performed in a reliable manner by the press fitting of the sealing element when the coupling element is poorly, or not at all, accessible, since according to the invention for this purpose the two ring elements are simply displaced in relation to each other. Thus, neither is any force transmitted in the longitudinal direction onto the corrugated pipe or the coupling piece during the press fitting, which corrugated pipe and coupling piece thereby remain free of stress. The adapting and maintaining of predetermined target lengths of the coupling connection joined to the corrugated pipe is significantly facilitated according to the invention, wherein furthermore the reaching of the functional position can be visually checked in a simple manner. Furthermore, an especially compact and easy to produce connection, especially a permanent one, is achieved, in which the sealing element is arranged in the force shunt, so that the seal and thus the sealing effect is not affected by an external or a thermal loading of the preferably helically corrugated pipe.

35

Preferably, the sealing chamber is formed in a transition region, in a manner bridging said transition region, between the corrugated pipe and a circumferential region of the

coupling element, so that the sealing element lies at the same time against the corrugated pipe and the coupling element, sealing these off against each other.

5 Since the ring elements can be permanently fixed in a predetermined relative position by the fixing element, said fixing element having a securing ring and being situated in the contact region between the outer circumferential surface of the one ring element and the inner circumferential surface
10 of the other ring element, a quick and reliable fixation of the two ring elements is achieved, wherein furthermore the fixing element is optimally protected against environmental factors, as well as tampering attempts. Furthermore, this realizes a slender and circumferentially smooth, preferably
15 cylindrical design, which makes the laying of the corrugated pipe coupled in this way appreciably easier.

According to the invention, the ring element secured on the corrugated pipe may alternatively enclose the other ring
20 element on the outside or, conversely, is encircled by it on the outside. It is especially advantageous, however, if the first ring element can be fixed to the corrugated pipe, because in this way two sleevelike ring elements of approximately equal material thickness can be realized, which
25 in particular are subject to a similar corresponding thermal expansion and furthermore can be economically fabricated.

The sealing chamber is delimited by one of the ring elements radially at the circumference and by a respective end face of
30 the two ring elements in a respective axial direction. Especially preferably, the sealing chamber is delimited in the axial direction by a respective surface of the two ring elements that is inclined with respect to the cross-sectional plane, which surface thus results in a directional
35 displacement and compression in a radially inward pointing direction. The sealing element is thus pressed deliberately against the transition region between the corrugated pipe and the supporting ring, which further improves the sealing

effect.

The coupling connection is not confined to a single coupling element. Instead, the coupling connection may also be designed
5 for the connecting of a plurality of corrugated pipes or as a branching element, in that the coupling connection for connecting at least two corrugated pipes is equipped with a plurality of supporting rings and a plurality of pairs of first and second ring elements. Of course, this does not rule
10 out a variant in which the coupling element is designed as a simple pipe socket, for example for coupling by means of a welded connection.

The ring elements may have different dimensions in regard to
15 their axial length. However, it is especially practical for the ring elements in the functional position to each have an end face arranged in a common cross-sectional plane of the coupling connection, so that when assembling the coupling connection it is possible by checking the two end faces to
20 ensure the desired target position corresponding to a common closure plane in a simple manner by means of a visual check.

The sealing effect can be limited to the region of the portion of the coupling element forming the supporting ring, in order
25 to ensure the desired functionality of the coupling connection. Furthermore, a variant is especially expedient in which the second ring element can be applied in particular sealingly with respect to the coupling element at the circumference, so as to achieve a further improved sealing.

30 Furthermore, it is advantageous for the second ring element to be connected to the coupling element and/or the first ring element in a rotationally fixed manner. This prevents the coupling element with the supporting ring from twisting
35 relative to the ring elements and thus being able to be unscrewed from the corrugated pipe. For example, a formation running parallel to the longitudinal axis in the manner of a feather key or a spline is suitable for a rotationally fixed

connection of this kind.

The seal can be adapted without difficulty to the respective purposes of use, without having to alter the design configuration for this purpose. However, it is especially
5 advisable for the sealing element to be a sealing ring having a substantial material fraction composed of graphite.

The invention allows for various embodiments. For further
10 illustration of its basic principle, one of these is represented in the drawing and described in the following. In said drawing, each time in a sectional side view,

Fig. 1 Shows a coupling connection, in which an inner ring
15 element is secured to a corrugated pipe;

Fig. 2 shows a modified coupling connection as per Figure 1 for the connecting of two corrugated pipes;

20 Fig. 3 shows a variant of a coupling connection, in which an outer ring element is secured to the corrugated pipe.

Figure 1 shows in a sectional side view a coupling connection 1 for corrugated pipes 2, which is fitted with a coupling
25 element 3 for a coupling (not shown), for example to stationary elements. The coupling element 3 is joined as a single part to a supporting ring 4, which is formed by a portion of the coupling element 3 provided with an external thread 5. This portion, forming the supporting ring 4, lies in
30 form fit against an inner wall surface 6 of the corrugated pipe 2 by being screwed into the corrugated pipe 2. On a circumferential surface 7 of the corrugated pipe 2 there is secured a first ring element 9 provided with a corresponding internal thread 8, wherein one end portion of the corrugated
35 pipe 2 is enclosed between the supporting ring 4 and the first ring element 9 and thereby fixed. In this way, the force occurring during operation is transmitted from the corrugated pipe 2 by means of the first ring element 9 onto the

supporting ring 4 and thus onto the coupling element 3. In addition, an annular sealing chamber 10 is provided on the coupling connection 1 in a transition region between the supporting ring 4 and the corrugated pipe 2 at the circumference, said sealing chamber holding a sealing element 11. The sealing element 11 is designed as a graphite ring and is compressed by a second ring element 12 in the sealing chamber by around 20% to 40%. For this purpose, the second ring element 12 encloses both the coupling element 3 and the first ring element 9 circumferentially and is movable in translation relative to them. Thus, by virtue of an outer circumferential surface 13 of the first ring element 9 lying in a contact region against an inner circumferential surface 14 of the second ring element 12 and the ring elements 9, 12 being moved in translation relative to each other along a sliding guide formed by the contact region, the sealing element 11 is compressed in the sealing chamber 10 by means of opposite inclined surfaces 15, 16 of the two ring elements 9, 12 and the desired sealing is achieved. In this functional position of the ring elements 9, 12, a fixing element 17 designed as a securing ring engages at the same time in a groove 18 in the outer circumferential surface 13 of the first ring element 9 and in a further groove 19 in the inner circumferential surface 14 of the second ring element 12 and thus forms a permanent form-fitting connection. For this purpose, the inner circumferential surface 14 of the second ring element 12 has a conical portion 20, by which the fixing element 17 is pressed into the groove 18 of the first ring element 9 against an elastic restoring force of the fixing element 17 by virtue of the relative translatory movement of the ring elements 9, 12 and automatically protrudes upon reaching the aligned position of the two grooves 18, 19.

Figure 2 shows a variant of a coupling connection 24 designed as a pipe coupling in a sectional view, by which coupling connection two structurally identical corrugated pipes 2 are joined together. The coupling element 3 is joined at both end portions as a single piece to a supporting ring 4 formed by a

respective end portion. This portion forming the supporting ring 4 lies against an inner wall surface 6 of the corrugated pipe 2 in form fit, being screwed into the corrugated pipe 2. On a circumferential surface 7 of the two corrugated pipes 2 there is secured respectively a first ring element 9 provided with a corresponding internal thread 8, wherein an end portion of the corrugated pipe 2 is enclosed between the supporting ring 4 and the first ring element 9 and is thereby secured. A second ring element 12 enclosing the two first ring elements 9 as well as the coupling element 3 circumferentially is movable in translation relative to them. For the installing, the two corrugated pipes 2 with the respective supporting ring 4 and the first ring element 9 are introduced in to the second ring element 12 from opposite sides after inserting the sealing element 11. In this functional position of the ring elements 9, 12, a fixing element 17 designed as a securing ring engages respectively in the grooves, lying opposite one another in this case, of the ring elements 9, 12 with form fit and thus forms a reliable and mechanically highly sturdy connection.

20

In the variant of a coupling connection 21 shown in Figure 3, on the other hand, a first ring element 22 secured to the corrugated pipe 2 is larger than a second ring element 23.

25 In this way, the second ring element 23 is inserted between the first ring element 22 and the coupling element 3 into the annular groove delimited by them. The sealing chamber 10 is thus reduced by the pushing of the second ring element 23 into the first ring element 22 and the sealing element 11 is
30 compressed as a result.

Patentkrav

1. Tilslutningsforbindelse (1, 21, 24) for bølgerør (2) med et tilslutningselement (3), en støttering (4), der kan lægges
5 formsluttende an mod en indre vægflade (6) af bølgerøret (2), et første ringelement (9, 22), der kan fastlægges aksialt på en omkredsflade (7) af bølgerøret (2), hvor et afsnit af bølgerøret (2) er indesluttet mellem støttingen (4) og det første ringelement (9, 22) og kan fastlægges aksialt
10 ubevægeligt, og hvor et ringformet tætningskammer (10), som er indesluttet i et overgangsområde mellem støttingen (4) og bølgerøret (2) på omkredssiden, optager et tætningselement (11), som i en funktionsstilling, der kan fastlægges ved hjælp af et fikseringselement (17) i tilslutningsforbindelsen (1,
15 21, 24), er belastet med en deformationskraft, hvor et andet ringelement (12, 23) omslutter tilslutningselementet (3) på omkredssiden og kan lægges an mod dette tilslutningselement på omkredssiden og er translatorisk bevægeligt, hvor det første ringelement (9, 22) og det andet ringelement (12, 23) er
20 anbragt koaksialt i forhold til hinanden, således at en ydre omkredsflade (13) af det ene ringelement (9, 23) i et kontaktområde ligger an mod en indre omkredsflade (14) af det andet ringelement (12, 22), og ringelementerne (9, 12, 22, 23) langs en ved hjælp af kontaktområdet dannet skydeføring er
25 translatorisk bevægelige relativt i forhold til hinanden, hvor tætningselementet (11) kan komprimeres i tætningskammeret (10) på grund af den relative translatoriske bevægelse af ringelementerne (9, 12, 22, 23), og den relative position af ringelementerne (9, 12, 22, 23), der svarer til denne
30 funktionsstilling, kan fastlægges af fikseringselementet (17), og hvor støttingen (4) er forbundet i et stykke med tilslutningselementet (3), kendetegnet ved, at i ringelementernes (9, 12) funktionsstilling griber et som sikringsring udført fikseringselement (17) samtidig
35 formsluttende ind i en not (18) i det første ringelements (9) ydre omkredsflade (13) og ind i en yderligere not (19) i det andet ringelements (12) indre omkredsflade (14), og ringelementerne (9, 12, 22, 23) i funktionsstillingen på grund

af fikseringselementet (17) er uløseligt forbundet, og at den indre omkredsflade og/eller den ydre omkredsflade (13) har et konisk eller kalotformet afsnit (20), ved hjælp af hvilket fikseringselementet (17) på grund af ringelementernes (9, 12, 22, 23) translatoriske relative bevægelse imod en elastisk tilbagestillingskraft i fikseringselementet (17) presses ind i det første ringelements (9) not (18) og ved opnåelse af de to noters (18, 19) flugtende position automatisk springer frem.

10 2. Tilslutningsforbindelse (1, 21, 24) ifølge krav 1, kendetegnet ved, at det første ringelement (9, 22) kan fikseres på bølgerøret (2).

15 3. Tilslutningsforbindelse (1, 21, 24) ifølge i det mindste et af de foregående krav, kendetegnet ved, at tætningskammeret (10) i aksial retning er begrænset af hver gang en i forhold til tværsnitsplanet skrånende flade (15, 16) på de to ringelementer (9, 12, 22, 23).

20 4. Tilslutningsforbindelse (24) ifølge i det mindste et af de foregående krav, kendetegnet ved, at tilslutningsforbindelsen (24) med henblik på forbindelsen af i det mindste to bølgerør (2) er udstyret med flere støtteringe (4) og flere par af første og anden ringelementer (9, 12).

25 5. Tilslutningsforbindelse (1, 21, 24) ifølge i det mindste et af de foregående krav, kendetegnet ved, at ringelementerne (9, 12, 22, 23) i funktionsstillingen hver især har en frontflade, der er anbragt i et fælles tværsnitsplan for 30 tilslutningsforbindelsen (1, 21, 24).

35 6. Tilslutningsforbindelse (1) ifølge i det mindste et af de foregående krav, kendetegnet ved, at det andet ringelement (12) kan lægges tætnende an i forhold til tilslutningselementet (3).

7. Tilslutningsforbindelse (1, 21, 24) ifølge i det mindste et af de foregående krav, kendetegnet ved, at det andet

ringelement (12, 23) er forbundet ikke-drejeligt med tilslutningselementet (3) og/eller det første ringelement (9, 22).

- 5 8. Tilslutningsforbindelse (1, 21, 24) ifølge i det mindste et af de foregående krav, kendetegnet ved, at tætningsselementet (11) er en tætningsring med en væsentlig materialeandel af grafit.

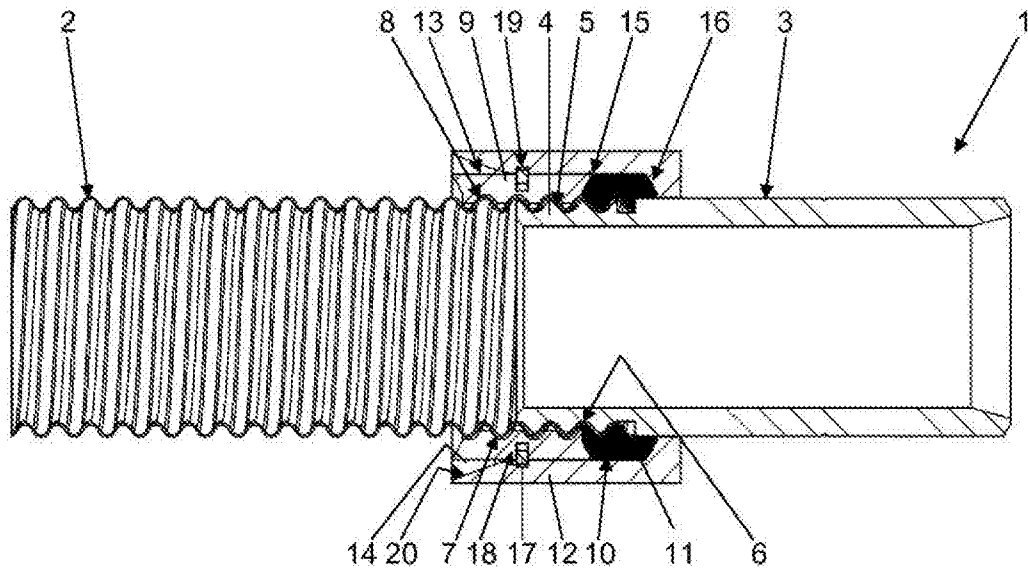

Fig. 1

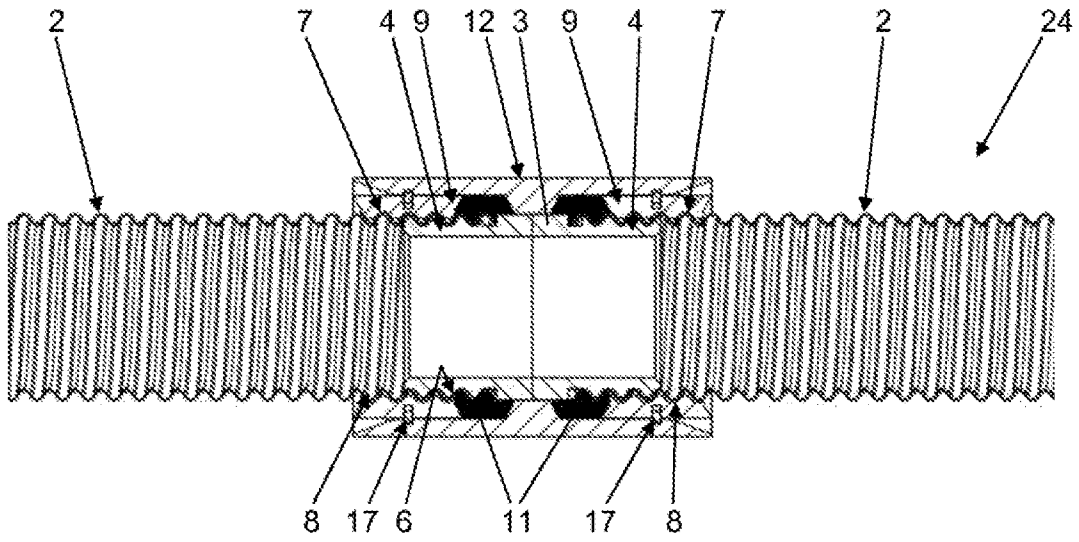

Fig. 2

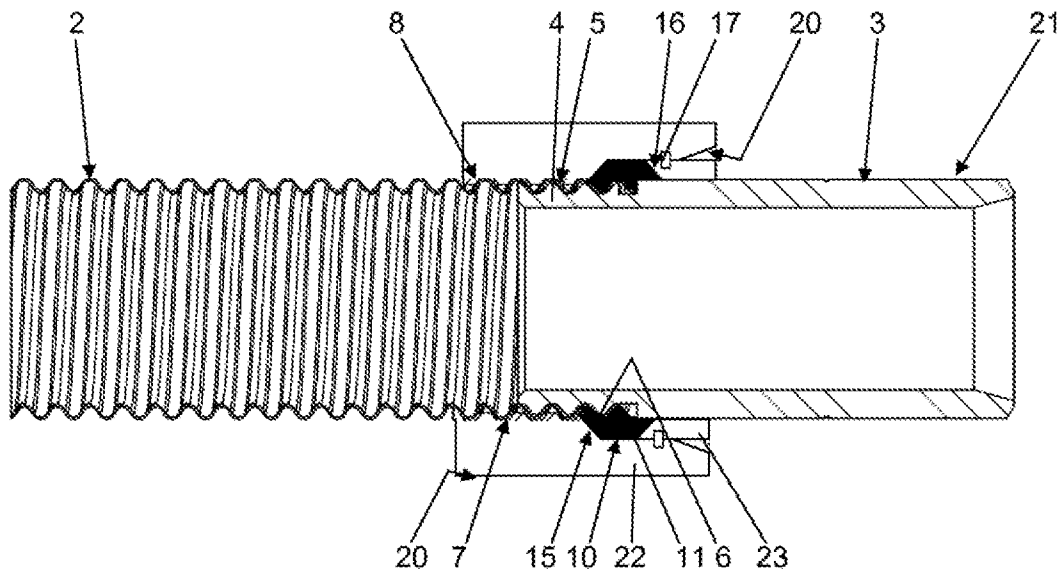

Fig. 3