



US00D910382S

(12) **United States Design Patent** (10) **Patent No.:** **US D910,382 S**
Rane et al. (45) **Date of Patent:** **** Feb. 16, 2021**

(54) **INSULATING DEVICE**

FOREIGN PATENT DOCUMENTS

(71) Applicant: **YETI Coolers, LLC**, Austin, TX (US)

AU 2015203857 A1 7/2015
CA 2512003 A1 1/2007

(72) Inventors: **Mark Rane**, Austin, TX (US); **Dustin Bullock**, Austin, TX (US)

(Continued)

(73) Assignee: **YETI Coolers, LLC**, Austin, TX (US)

OTHER PUBLICATIONS

(**) Term: **15 Years**

Dec. 11, 2019—(CN) Second Office Action—App. 201680079515.2.

(Continued)

(21) Appl. No.: **29/655,306**

Primary Examiner — Terry A Wallace

(22) Filed: **Jul. 2, 2018**

(74) *Attorney, Agent, or Firm* — Banner & Witcoff, Ltd.

(57) **CLAIM**

The ornamental design for an insulating device, as shown and described.

Related U.S. Application Data

(63) Continuation of application No. 29/604,256, filed on May 16, 2017, now Pat. No. Des. 821,824.

DESCRIPTION

(51) **LOC (13) Cl.** **07-01**

FIG. 1 is a top, front, left perspective view of an insulating device showing our new design in an open configuration; FIG. 2 is a front view thereof;

(52) **U.S. Cl.**

FIG. 3 is a rear view thereof; FIG. 4 is a right side view thereof;

USPC **D7/605**

FIG. 5 is a left side view thereof; FIG. 6 is a top view thereof;

(58) **Field of Classification Search**

USPC D7/605–607, 629, 630; D3/272–274, D3/201–206, 203.1–203.8

FIG. 7 is a bottom view thereof; FIG. 8 is a top, front, right perspective view of an insulating device showing our new design in a closed configuration;

CPC .. A45C 11/20; A45C 5/14; A45C 5/03; A45C 9/00; A47B 77/08; A47J 41/022; A47G

FIG. 9 is a front view thereof; FIG. 10 is a rear view thereof;

19/2288; F25B 19/00; B62B 3/003; B65D 81/3823; B65D 81/3858; B65D 81/3813;

FIG. 11 is a right side view thereof; FIG. 12 is a left side view thereof;

B65D 81/3888; B65D 81/3816; F25D 3/08; F25D 3/12; F25D 3/14; F25D

FIG. 13 is a top view thereof; and, FIG. 14 is a bottom view thereof.

(Continued)

The broken lines immediately adjacent to the shaded area represent unclaimed boundaries of the design. The broken lines showing the remainder of the insulating device represent unclaimed subject matter and form no part of the claimed design.

(56) **References Cited**

U.S. PATENT DOCUMENTS

1,000,103 A 8/1911 Mills
1,001,141 A 8/1911 Grosskopf
1,002,984 A 9/1911 Gilmore

(Continued)

1 Claim, 14 Drawing Sheets

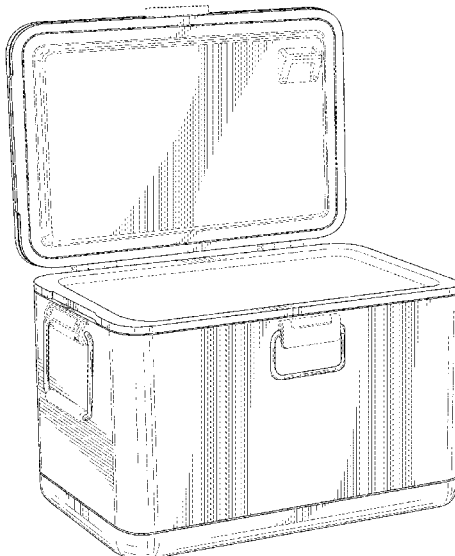

(58) **Field of Classification Search**
 CPC 27/00; F25D 2331/804; F25D 2400/08;
 F25D 31/005
 See application file for complete search history.

(56) **References Cited**

U.S. PATENT DOCUMENTS

2,184,336 A 12/1939 Devine
 2,239,128 A 4/1941 Sykes
 2,301,657 A 11/1942 Hlavaty
 2,555,126 A 5/1951 Greve
 2,570,300 A 10/1951 Acton
 2,892,564 A 6/1959 Morrison
 2,927,712 A 3/1960 Armato, Sr.
 2,980,285 A 4/1961 Parsons
 3,025,995 A 3/1962 Koelsch et al.
 3,035,733 A 5/1962 Knapp
 3,168,362 A 2/1965 Perkins
 3,302,358 A 2/1967 Jackson
 3,384,264 A 5/1968 Wallace et al.
 3,389,824 A 6/1968 Berchtold
 3,406,532 A 10/1968 Rownd
 3,420,363 A 1/1969 Blickensderfer
 3,915,304 A 10/1975 Pasco et al.
 3,979,007 A 9/1976 Thornbloom, Jr.
 4,024,731 A * 5/1977 Branscum B65D 81/3823
 215/385
 4,047,633 A 9/1977 Trombly
 4,143,695 A 3/1979 Hoehn
 4,249,392 A 2/1981 Hotta
 4,537,044 A 8/1985 Putnam
 4,573,581 A 3/1986 Galloway et al.
 4,577,475 A 3/1986 Herrera
 4,873,841 A 10/1989 Bradshaw et al.
 5,024,471 A 6/1991 Kahl et al.
 5,040,834 A 8/1991 Kahl et al.
 5,082,335 A 1/1992 Cur et al.
 5,123,681 A 6/1992 Kos et al.
 5,153,561 A 10/1992 Johnson
 D331,064 S 11/1992 Wilson et al.
 5,175,975 A 1/1993 Benson et al.
 5,176,215 A 1/1993 Ackerman
 5,329,787 A 7/1994 Friday
 5,392,960 A 2/1995 Kendt et al.
 5,408,832 A 4/1995 Boffito et al.
 5,433,085 A 7/1995 Rogers
 D362,900 S 10/1995 Miska
 D363,767 S 10/1995 Swaim
 5,465,078 A 11/1995 Jones, Jr.
 5,570,588 A 11/1996 Lowe
 5,605,056 A 2/1997 Brown et al.
 5,638,896 A 6/1997 Nishino et al.
 5,655,570 A 8/1997 Page
 5,671,611 A 9/1997 Quigley
 5,780,521 A 7/1998 Shmidt et al.
 5,827,385 A 10/1998 Meyer et al.
 5,843,353 A 12/1998 De Vos et al.
 5,845,515 A 12/1998 Nelson
 5,865,037 A 2/1999 Bostic
 5,875,916 A 3/1999 Crockett, Sr. et al.
 5,896,641 A 4/1999 Yamada et al.
 5,904,264 A 5/1999 Yamada et al.
 5,918,478 A 7/1999 Bostic et al.
 5,943,876 A 8/1999 Meyer et al.
 6,003,719 A 12/1999 Stewart, III
 D418,397 S 1/2000 Sasa
 6,026,978 A 2/2000 Clegg et al.
 6,027,249 A 2/2000 Bielinski
 6,067,813 A 5/2000 Smith
 D429,966 S 8/2000 Israel et al.
 6,116,285 A 9/2000 Wilson
 6,128,914 A 10/2000 Tamaoki et al.
 6,131,404 A 10/2000 Hase et al.
 6,179,155 B1 1/2001 Komiya et al.
 6,192,703 B1 2/2001 Salyer et al.
 6,193,097 B1 2/2001 Martin Perianes et al.

6,220,473 B1 4/2001 Lehman et al.
 6,234,341 B1 5/2001 Tattam
 6,244,066 B1 6/2001 LaRose
 6,244,458 B1 6/2001 Frysinger et al.
 6,253,942 B1 7/2001 Elias
 6,305,185 B1 10/2001 Sloan
 6,308,518 B1 10/2001 Hunter
 6,325,281 B1 12/2001 Grogan
 6,349,559 B1 2/2002 Hasanovic
 6,381,981 B1 5/2002 Yaddgo et al.
 6,397,620 B1 6/2002 Kelly et al.
 6,415,623 B1 7/2002 Jennings et al.
 6,446,382 B1 9/2002 Cloutier et al.
 6,457,323 B1 10/2002 Marotta
 6,488,172 B1 12/2002 Wenning et al.
 6,497,438 B1 12/2002 Holub et al.
 6,536,089 B1 3/2003 Komiya et al.
 6,536,228 B1 3/2003 Hall
 6,651,444 B2 11/2003 Morimoto et al.
 6,698,230 B1 3/2004 Brusky
 6,763,678 B2 7/2004 Harper
 6,782,711 B2 8/2004 Abfalter
 6,863,949 B2 3/2005 Ehrmantraut
 6,913,160 B2 7/2005 Bourreau et al.
 6,929,137 B1 8/2005 Granger et al.
 6,938,968 B2 9/2005 Tanimoto et al.
 D510,370 S 10/2005 Bertani
 7,057,527 B2 6/2006 Hunter
 7,100,393 B2 9/2006 D'Angelo
 7,140,508 B2 11/2006 Kuhn et al.
 7,147,125 B1 12/2006 Slovak et al.
 D544,756 S 6/2007 Jones et al.
 D544,757 S 6/2007 Jones et al.
 D544,758 S 6/2007 Jones et al.
 D544,759 S 6/2007 Jones et al.
 D545,404 S 6/2007 Nightlinger et al.
 D545,405 S 6/2007 Nightlinger et al.
 D547,129 S 7/2007 Jones et al.
 D547,617 S 7/2007 Jones et al.
 7,263,855 B2 9/2007 Meyer et al.
 7,269,969 B2 9/2007 Strickland et al.
 D552,426 S 10/2007 Jones et al.
 7,313,928 B2 1/2008 Girard
 D566,479 S 4/2008 Kabalin
 D569,955 S 5/2008 Chen
 7,389,608 B1 6/2008 MacKay
 7,500,593 B2 3/2009 Mayer
 7,604,290 B1 10/2009 Giordano
 7,669,436 B2 3/2010 Mogil et al.
 7,681,405 B2 3/2010 Williams
 7,722,204 B1 * 5/2010 Sandberg F25D 27/005
 362/155
 7,784,301 B2 8/2010 Sasaki et al.
 7,815,269 B2 10/2010 Wenning et al.
 7,833,605 B2 11/2010 Tenra et al.
 D634,982 S 3/2011 Melchert et al.
 7,937,958 B2 5/2011 Shinya et al.
 7,950,246 B1 5/2011 Mayer et al.
 D646,362 S 10/2011 Olateru et al.
 8,065,889 B1 11/2011 Silberman
 8,066,139 B2 11/2011 Baughman
 D652,262 S 1/2012 Yang et al.
 8,176,749 B2 5/2012 LaMere et al.
 8,215,518 B2 7/2012 Hyde et al.
 8,230,697 B2 7/2012 Lavallee
 8,256,242 B1 9/2012 Evans
 8,381,939 B2 2/2013 Schultz et al.
 8,418,812 B1 4/2013 Rosen et al.
 8,443,623 B2 5/2013 Matta et al.
 8,573,002 B2 11/2013 Ledoux et al.
 8,622,235 B2 1/2014 Suchecki
 8,627,968 B2 1/2014 Baban
 8,701,916 B2 4/2014 Cook et al.
 8,763,423 B2 7/2014 Tattam
 8,763,847 B2 7/2014 Mortarotti
 8,800,795 B2 8/2014 Hwang
 D716,916 S 11/2014 Snow
 8,875,934 B2 11/2014 Dekka
 8,881,398 B2 11/2014 Hanley et al.

(56)

References Cited

U.S. PATENT DOCUMENTS

8,887,515	B2	11/2014	Patstone	2008/0127668	A1	6/2008	DeVito et al.
8,960,370	B2	2/2015	Langwald et al.	2008/0178629	A1	7/2008	Meether
8,986,805	B2	3/2015	Yoon et al.	2008/0245793	A1	10/2008	Hanson et al.
9,022,249	B2	5/2015	Ranade	2009/0001086	A1	1/2009	Roderick et al.
9,074,716	B2	7/2015	Nomura et al.	2009/0032541	A1	2/2009	Rogala et al.
9,074,717	B2	7/2015	Nomura et al.	2009/0071088	A1	3/2009	Viegas et al.
9,091,449	B2	7/2015	Donaldson et al.	2009/0078699	A1	3/2009	Mustafa et al.
9,139,352	B2	9/2015	Seiders et al.	2009/0078708	A1	3/2009	Williams
9,140,481	B2	9/2015	Cur et al.	2009/0126600	A1	5/2009	Zupancich et al.
9,163,871	B1	10/2015	Costello	2009/0193765	A1	8/2009	Lantz
D744,786	S *	12/2015	Bagwell D7/605	2009/0241584	A1	10/2009	Hayes et al.
D745,809	S *	12/2015	Rowley D7/605	2009/0283525	A1	11/2009	Martinez et al.
9,199,657	B2	12/2015	Martin	2010/0200599	A1	8/2010	Molthen et al.
D748,227	S	1/2016	von Lepel et al.	2010/0212351	A1	8/2010	Chapin et al.
D749,197	S	2/2016	von Lepel et al.	2010/0326993	A1	12/2010	Mayer et al.
9,259,090	B1	2/2016	Cronin	2011/0100868	A1	5/2011	Lantz
9,272,475	B2	3/2016	Ranade et al.	2011/0147391	A1	6/2011	Corder et al.
9,389,013	B2	7/2016	Rolek et al.	2011/0226003	A1	9/2011	Chaney et al.
9,464,751	B2	10/2016	Toshimitsu et al.	2011/0226785	A1	9/2011	Sakell
9,476,633	B2	10/2016	Allard et al.	2011/0248038	A1	10/2011	Mayer
9,527,652	B2	12/2016	Furneauux et al.	2011/0260351	A1	10/2011	Corradi et al.
9,550,618	B1	1/2017	Jobe	2011/0284556	A1	11/2011	Palmer et al.
9,555,946	B1	1/2017	Warman	2012/0132657	A1	5/2012	Seiders
D781,400	S	3/2017	Montoya et al.	2012/0225236	A1	9/2012	Cox
D784,089	S	4/2017	Furneauux et al.	2012/0237715	A1	9/2012	McCracken
9,688,048	B2	6/2017	Caps	2012/0297813	A1	11/2012	Hanley et al.
9,718,608	B2	8/2017	Tattam et al.	2012/0318808	A1	12/2012	McCormick
9,751,682	B2	9/2017	Mayer et al.	2013/0033854	A1 *	2/2013	Statham F25D 27/00 362/154
9,751,683	B1	9/2017	Jobe	2013/0140317	A1	6/2013	Roskoss
9,796,517	B2	10/2017	Seiders et al.	2013/0213978	A1	8/2013	Libourel et al.
9,821,945	B2	11/2017	Kuhn et al.	2013/0248649	A1	9/2013	Burd
9,828,165	B2	11/2017	Ranade et al.	2014/0008374	A1	1/2014	Lubart et al.
9,834,365	B2	12/2017	Pointer et al.	2014/0151382	A1	6/2014	White et al.
9,868,530	B2	1/2018	Burd	2014/0252010	A1	9/2014	Miller
9,878,841	B2	1/2018	Holderness et al.	2014/0352350	A1	12/2014	Wickline
9,890,990	B2	2/2018	Allard et al.	2014/0353317	A1	12/2014	Ranade et al.
9,901,153	B2	2/2018	Nash	2015/0090728	A1	4/2015	Lubart et al.
9,902,548	B2	2/2018	Seiders et al.	2015/0129597	A1	5/2015	McBroom et al.
D812,716	S	3/2018	Ebertowski et al.	2015/0166244	A1	6/2015	Wood et al.
9,944,449	B2	4/2018	Wood et al.	2015/0259126	A1	9/2015	McGoff et al.
9,950,851	B2	4/2018	Ranade	2015/0284169	A1	10/2015	Nehring
9,957,098	B2	5/2018	Jobe	2015/0369529	A1	12/2015	Monroe
9,957,099	B2	5/2018	White et al.	2016/0025399	A1	1/2016	Miller et al.
9,957,859	B2	5/2018	Cohen	2016/0039594	A1	2/2016	Ranade
9,975,686	B2	5/2018	Caps	2016/0090227	A1	3/2016	Miller
10,022,856	B2	7/2018	Bensman et al.	2016/0187045	A1	6/2016	McGarry
10,047,998	B2	8/2018	McGarry	2016/0230918	A1	8/2016	Kim et al.
10,065,786	B2	9/2018	Kuhn	2016/0244239	A1	8/2016	Nash
10,119,741	B2	11/2018	Jackson et al.	2016/0376082	A1	12/2016	Gammons et al.
10,247,468	B2	4/2019	Niemeyer et al.	2017/0045286	A1	2/2017	Ungor et al.
10,253,918	B2	4/2019	McCormick	2017/0121097	A1	5/2017	Pranadi et al.
10,272,934	B2	4/2019	DeFrancia	2017/0210542	A1	7/2017	Seiders et al.
10,279,979	B2	5/2019	Ranade	2017/0225869	A1	8/2017	Ranade
10,281,188	B2	5/2019	Shew	2017/0267438	A1	9/2017	Welch et al.
10,287,085	B2	5/2019	Kuhn	2017/0283157	A1	10/2017	Jobe
10,322,867	B2	6/2019	Furneauux et al.	2017/0305639	A1	10/2017	Kuhn et al.
10,329,074	B2	6/2019	Ranade et al.	2017/0313492	A1	11/2017	Seiders et al.
2001/0048985	A1	12/2001	Legare	2017/0321955	A1	11/2017	Hiemeyer et al.
2002/0130121	A1	9/2002	Taniguchi et al.	2018/0015938	A1	1/2018	DeFrancia
2002/0130131	A1	9/2002	Zucker et al.	2018/0016083	A1	1/2018	Knight et al.
2002/0144482	A1	10/2002	Henson et al.	2018/0044094	A1	2/2018	Seiders et al.
2003/0082357	A1	5/2003	Gokay et al.	2018/0073625	A1	3/2018	Miyazono et al.
2003/0102317	A1	6/2003	Gordon	2018/0080700	A1	3/2018	Cooper
2003/0124300	A1	7/2003	Gregorio et al.	2018/0086538	A1	3/2018	Jobe
2004/0045314	A1	3/2004	Roth et al.	2018/0100684	A1	4/2018	Allard et al.
2004/0185203	A1	9/2004	Gregorio et al.	2018/0110312	A1	4/2018	Nash
2004/0200232	A1	10/2004	Gano et al.	2018/0120021	A1	5/2018	Pompen et al.
2004/0231355	A1	11/2004	Mayer	2018/0141718	A1	5/2018	Ahlstrom et al.
2005/0189404	A1	9/2005	Kiaohai et al.	2018/0149400	A1	5/2018	Valencia
2005/0205584	A1	9/2005	Degermann	2018/0162626	A1	6/2018	Munie et al.
2006/0279947	A1 *	12/2006	Henley, Jr. F25D 27/00 362/154	2018/0194534	A1	7/2018	Jobe
2007/0125118	A1	6/2007	Hooper	2018/0320947	A1	11/2018	Jain et al.
2007/0217187	A1	9/2007	Blakely et al.	2018/0328644	A1	11/2018	Rizzo et al.
2008/0006628	A1	1/2008	Goncharko et al.	2019/0039811	A1	2/2019	Kuhn et al.
				2019/0071238	A1	3/2019	Seiders et al.
				2019/0152677	A1	5/2019	Hoyt

(56)

References Cited

U.S. PATENT DOCUMENTS

2019/0161240 A1 5/2019 Ahlstrom et al.
 2019/0210789 A1 7/2019 Ranade
 2019/0210790 A1 7/2019 Rizzo et al.

FOREIGN PATENT DOCUMENTS

CA 2981246 A1 11/2016
 CA 3001052 A1 4/2017
 CA 2968503 A1 11/2017
 CN 201128555 Y 10/2008
 CN 102305335 A 1/2012
 CN 102748558 A 10/2012
 CN 202463019 U 10/2012
 CN 202594113 U 12/2012
 CN 202644758 U 1/2013
 CN 103723379 A 4/2014
 CN 103968196 A 8/2014
 CN 104964124 A 10/2015
 CN 303435939 S 11/2015
 CN 205686756 U 11/2016
 CN 107434096 A 12/2017
 DE 10301318 A1 8/2004
 DE 202004016939 U1 3/2005
 DE 102004050549 A1 3/2006
 DE 102014003413 A1 9/2015
 DE 102014006579 A1 9/2015
 DE 102014007987 A1 12/2015
 DE 202015004047 U1 9/2016
 DE 202018102967 U1 6/2018
 DE 202018105918 U1 11/2018
 DE 102017007365 A1 2/2019
 EP 1177879 A2 2/2002
 EP 1177984 A2 2/2002
 EP 1428643 A2 6/2004
 EP 1505359 A1 2/2005
 EP 1896786 A2 3/2008
 EP 2022728 A1 2/2009
 EP 2372218 A1 10/2011
 EP 2765375 A2 8/2014
 EP 2883812 A1 6/2015
 EP 2943414 A1 11/2015
 EP 2985551 A1 2/2016
 EP 2989025 A1 3/2016
 EP 3004479 A1 4/2016
 EP 3018398 A1 5/2016
 EP 3114046 A1 1/2017
 EP 3117135 A1 1/2017
 EP 3148901 A1 4/2017
 EP 3212525 A2 9/2017
 EP 3215441 A1 9/2017
 EP 3224557 A1 10/2017
 EP 3224558 A1 10/2017
 EP 3249324 A1 11/2017
 EP 3253683 A1 12/2017
 EP 3265731 A1 1/2018
 EP 3359889 A1 8/2018
 EP 3368442 A1 9/2018
 EP 3408599 A1 12/2018
 EP 3436368 A1 2/2019

FR 2447174 A1 8/1980
 GB 2222791 A 3/1990
 GB 2538105 A 11/2016
 GB 2558682 A 7/2018
 JP 10654767 A 3/1994
 JP 2005035632 A 2/2005
 JP 2007246097 A 9/2007
 JP 2012062076 A 3/2012
 KR 20000010993 A 2/2000
 KR 20020021938 A 3/2002
 WO 9711842 A1 4/1997
 WO 05036076 A1 4/2005
 WO 12017903 A1 2/2012
 WO 2016070956 A1 5/2016
 WO 2016181111 A1 11/2016
 WO 17129377 A1 8/2017
 WO 17136754 A1 8/2017
 WO 17172029 A1 10/2017
 WO 17197230 A1 11/2017
 WO 18005859 A2 1/2018
 WO 18086752 A1 5/2018
 WO 18227047 A1 12/2018
 WO 19011478 A1 1/2019
 WO 19030225 A1 2/2019
 WO 19125527 A1 6/2019

OTHER PUBLICATIONS

Jul. 6, 2020—(CN) Office Action—App. No. 201680079515.2.
 Apr. 3, 2017—(WO) International Search Report and Written Opinion.
 60 Qt. Stainless Steel Party Cooler by Oakland Living, retrieved from Internet Jul. 6, 2017, URL: <https://www.wayfair.com/Oakland-Living-60-Qt.-Stainless-Steel-Party-Cooler-OAA2986.html>, 5 pp.
 80 Qt. Stainless Steel Rolling Cooler with Cover by Trinity, retrieved from Internet Jul. 6, 2017, URL: <https://www.mayfair.com/Trinity-80-Qt.-Stainless-Steel-Rolling-Cooler-with-Cover-TTY1173.html>, 5 pages.
 Coleman Steel Belted Review, retrieved from Internet Jul. 6, 2017, URL: <http://www.coolersonsale.com/coleman-steel-belted>, 10 pages.
 Igloo Stainless Steel 54-Quart Cooler, retrieved from Internet Feb. 5, 2018, URL: <https://www.igloocoolers.com/products/44669-legacy-stainless-steel-54-qt-cooler-stainless>, 4 pages.
 Kitchenall Beverage Air DW64-S Deep Well Beer Cooler, Stainless Steel, retrieved from Internet Jul. 6, 2017, URL: <https://www.kitchenall.com/beverage-air-dw64-s.html>, 3 pages.
 Koolatron 54-Qt Corona Stainless Steel Ice Chest Cooler, retrieved from Internet Jul. 6, 2017, URL: https://www.wayfair.com/Koolatron-54-Qt.-Corona-Stainless-Steel-Ice-Chest_Cooler-K001576.html, 4 pages.
 Portable Plastic Inner Ice Box Refrigerated Cooler box by Shengshi, retrieved from Internet Jul. 7, 2017, URL: https://www.alibaba.com/product-detail/Portable-Plastic-Inner-Ice-Box-Refrigerated_1073478882.html?s=p, 7 pages.
 Vintage Beer Cooler, retrieved from Internet Jul. 6, 2017, URL: <http://www.ebay.com/bhp/vintage-beer-cooler>, 8 pages.
 Aug. 13, 2018—(WO) International Search Report and Written Opinion—App. PCT/US2018/032972.
 Feb. 26, 2019—(CN) Office Action—App. 201680079515.2.

* cited by examiner

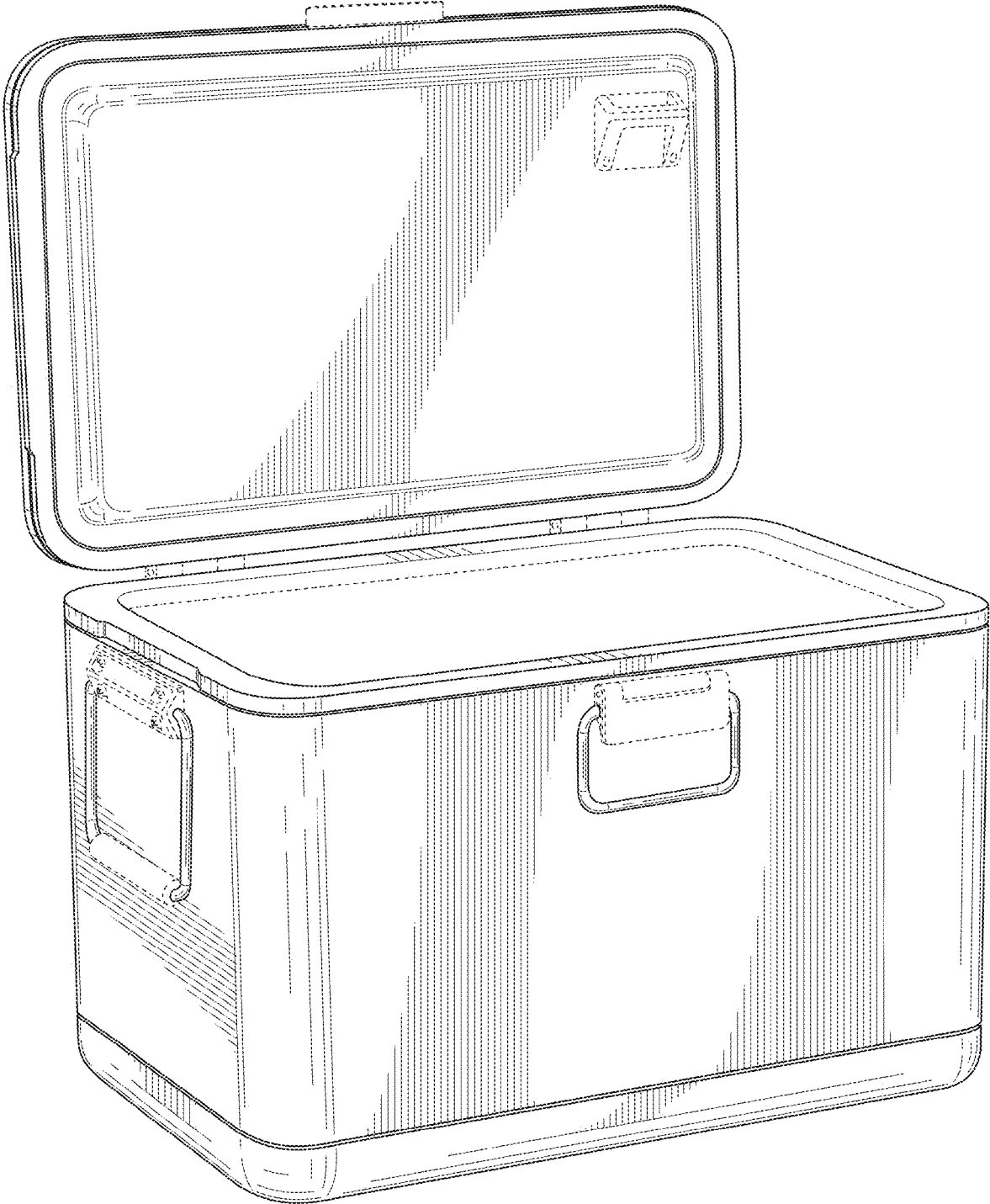

FIG. 1

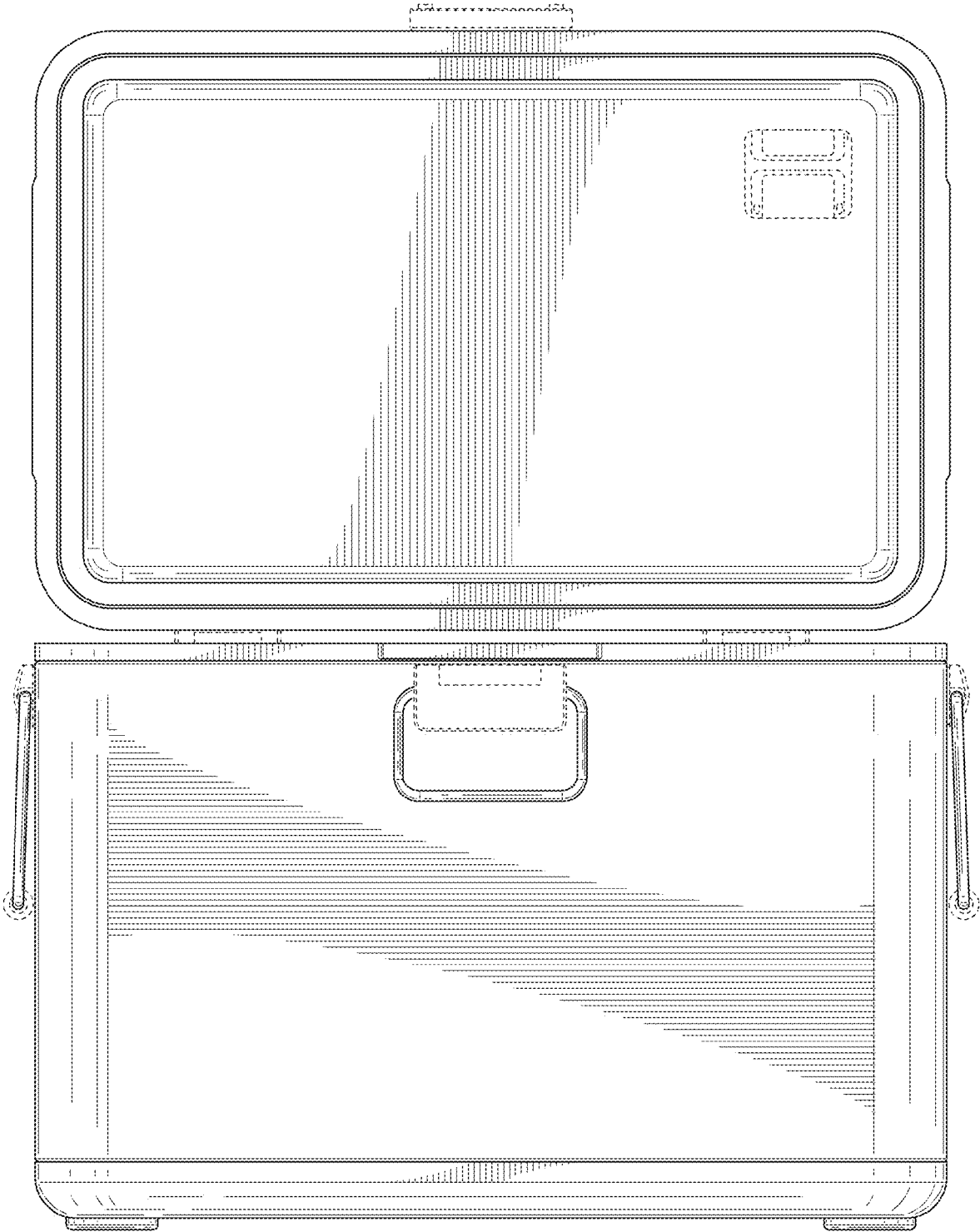

FIG. 2

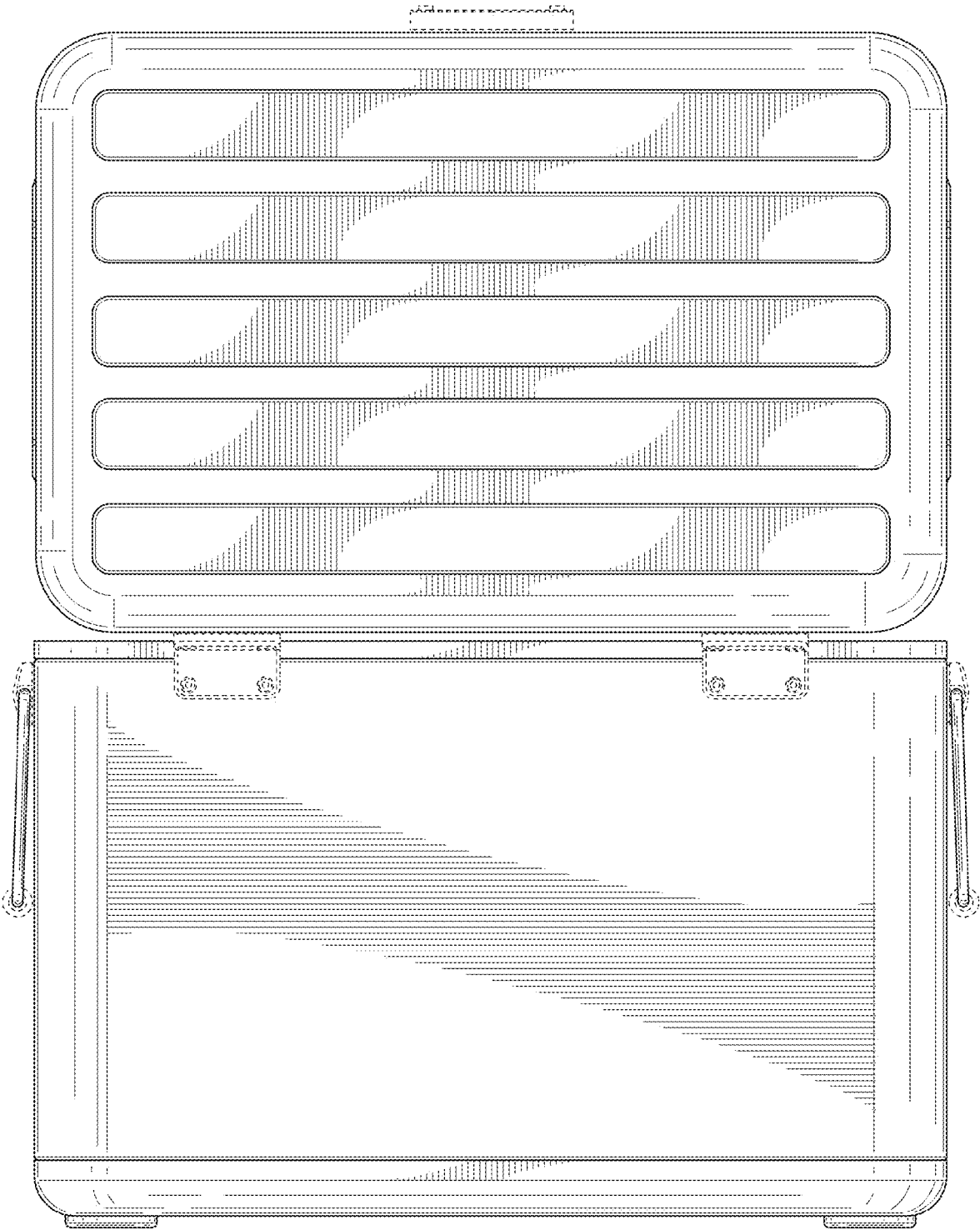

FIG. 3

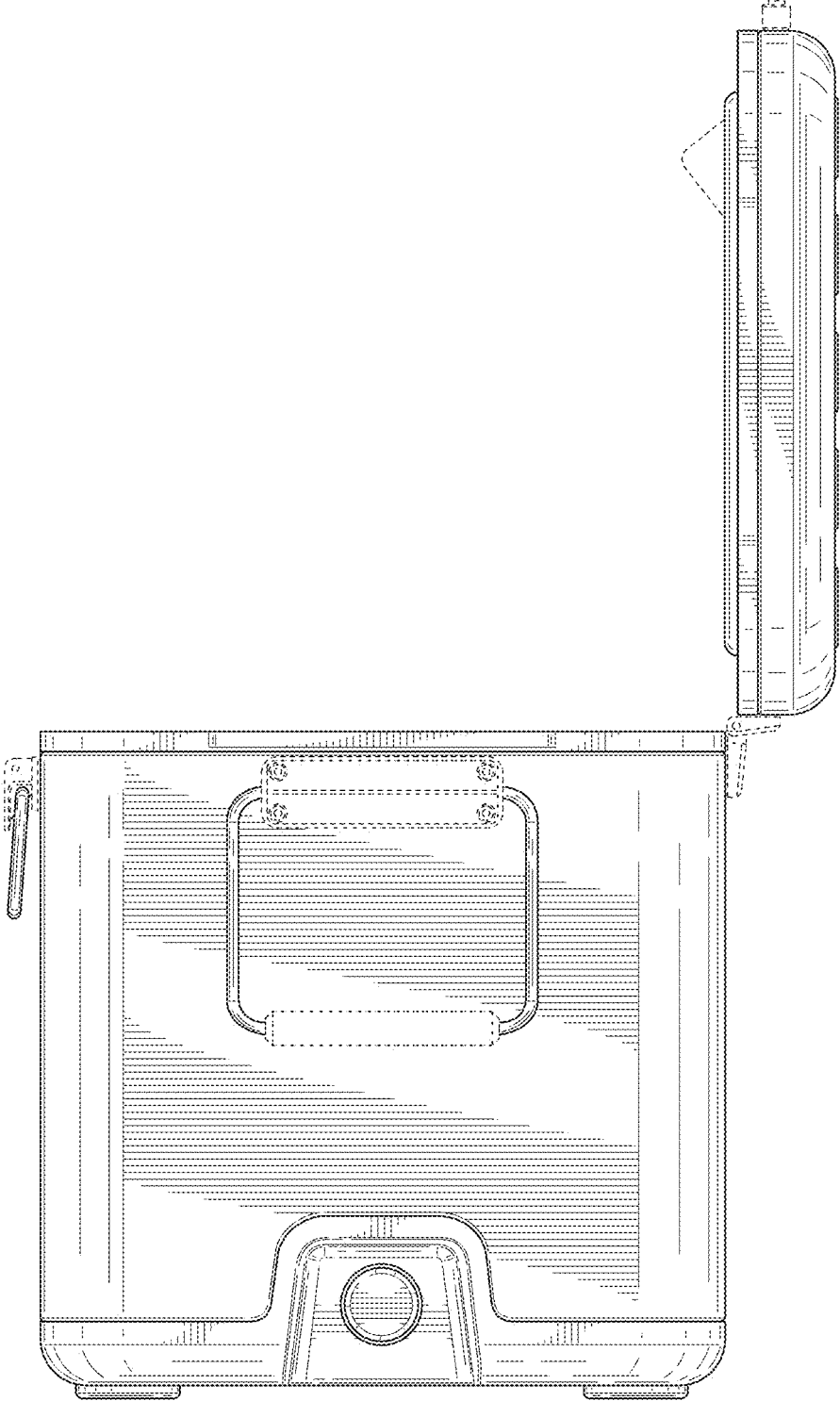

FIG. 4

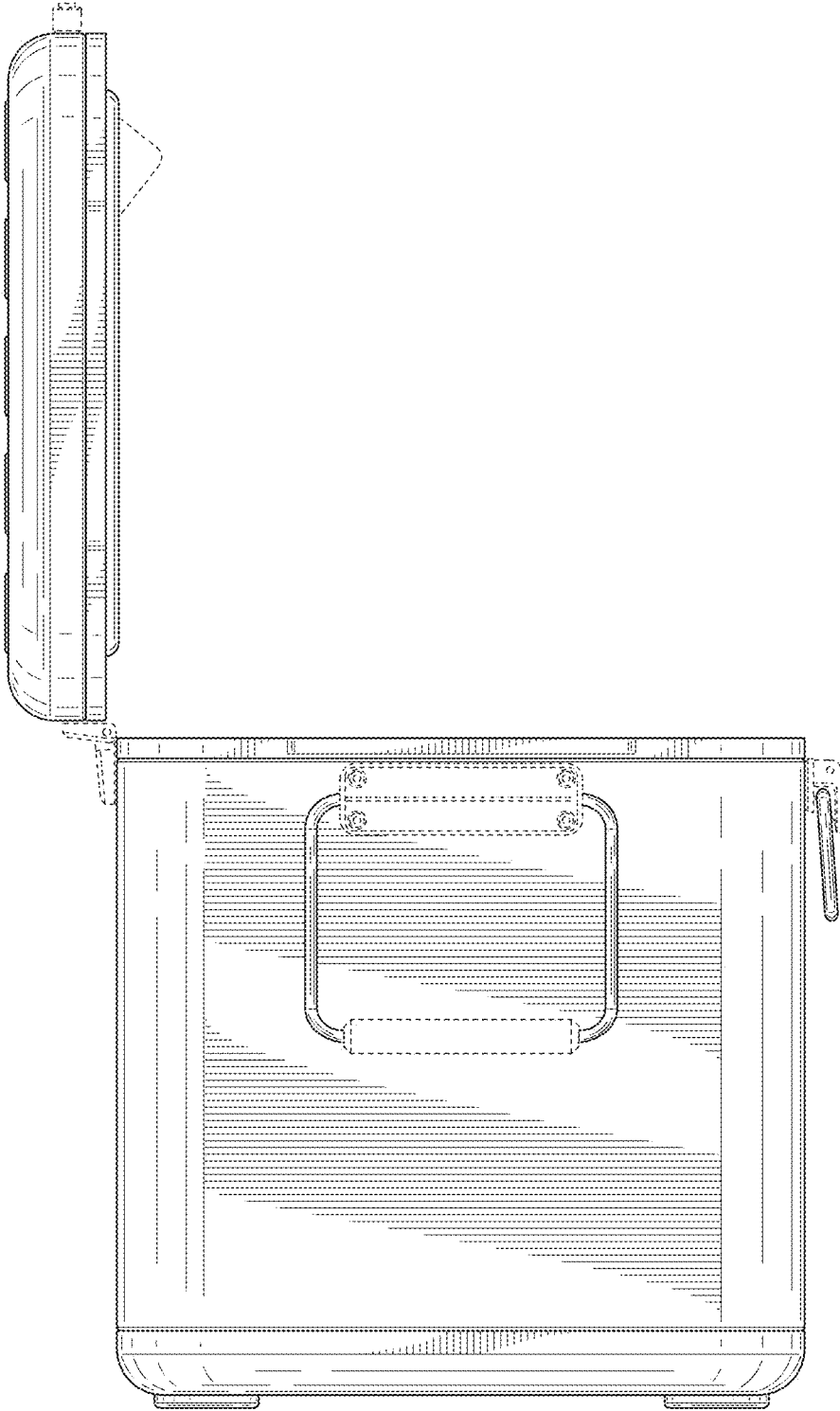

FIG. 5

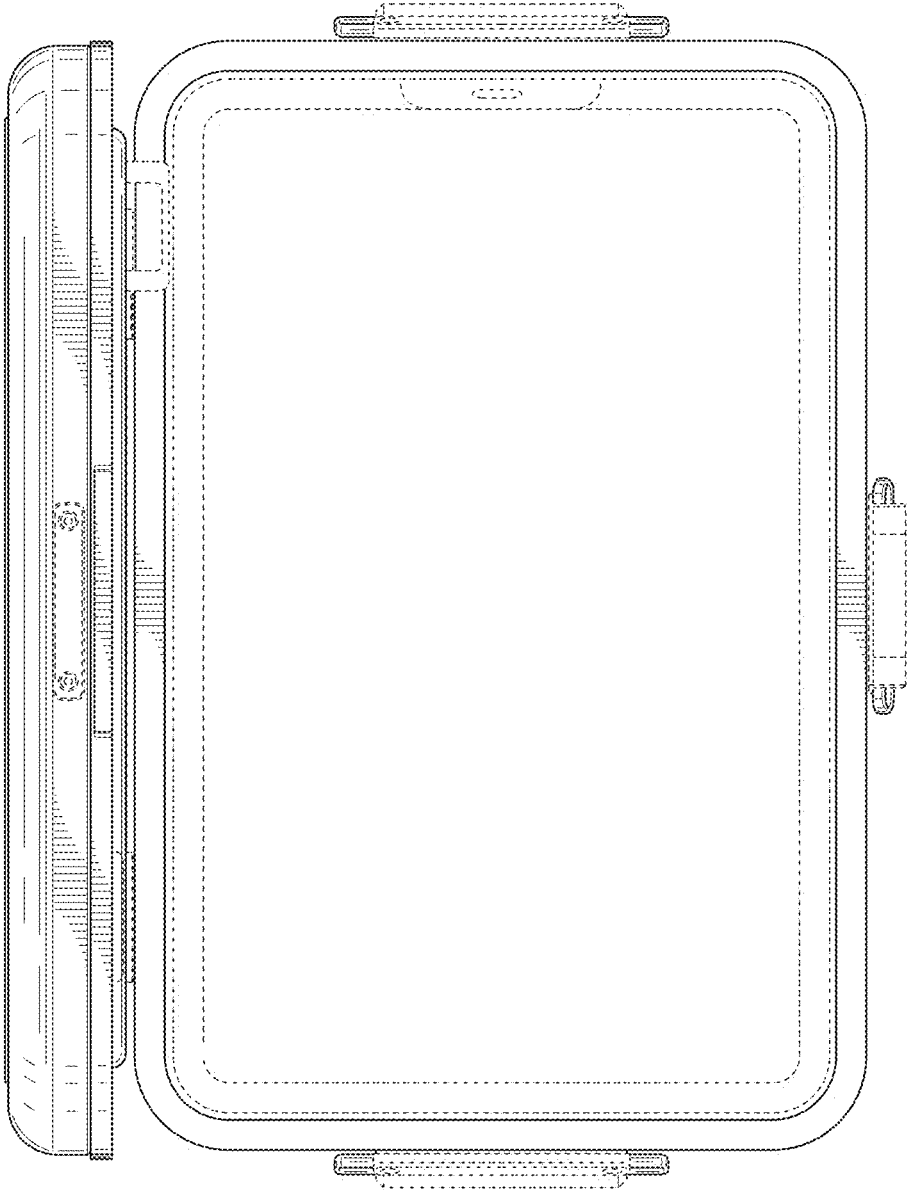

FIG. 6

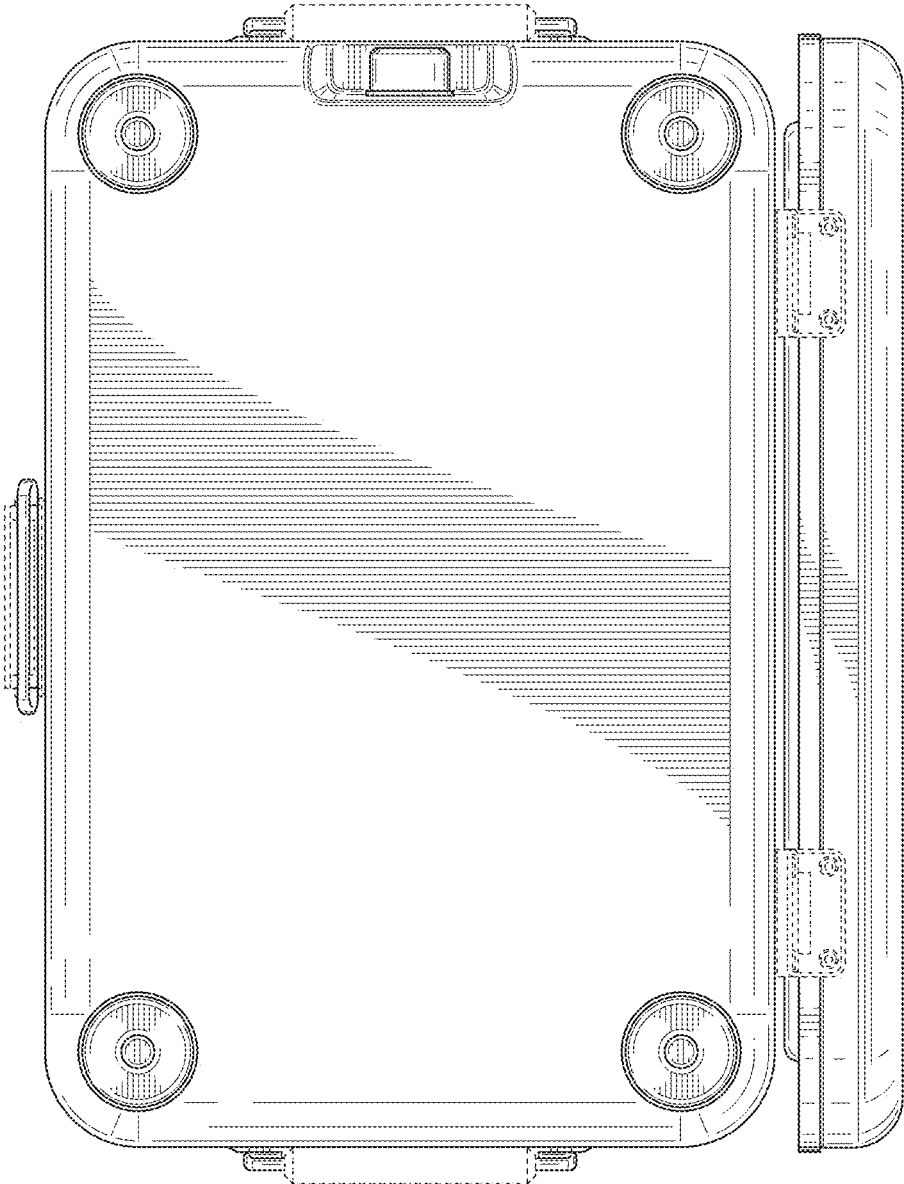

FIG. 7

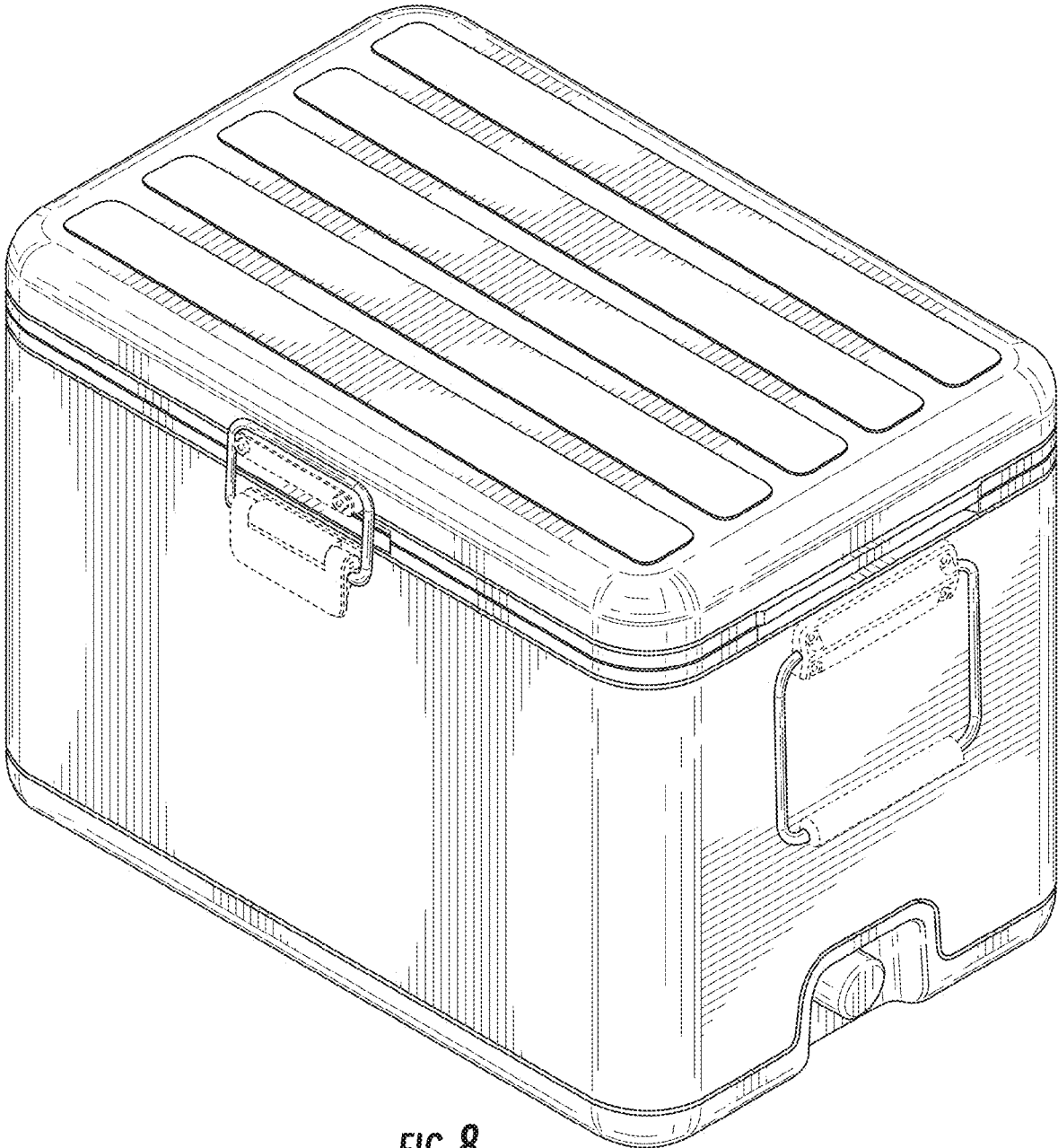

FIG. 8

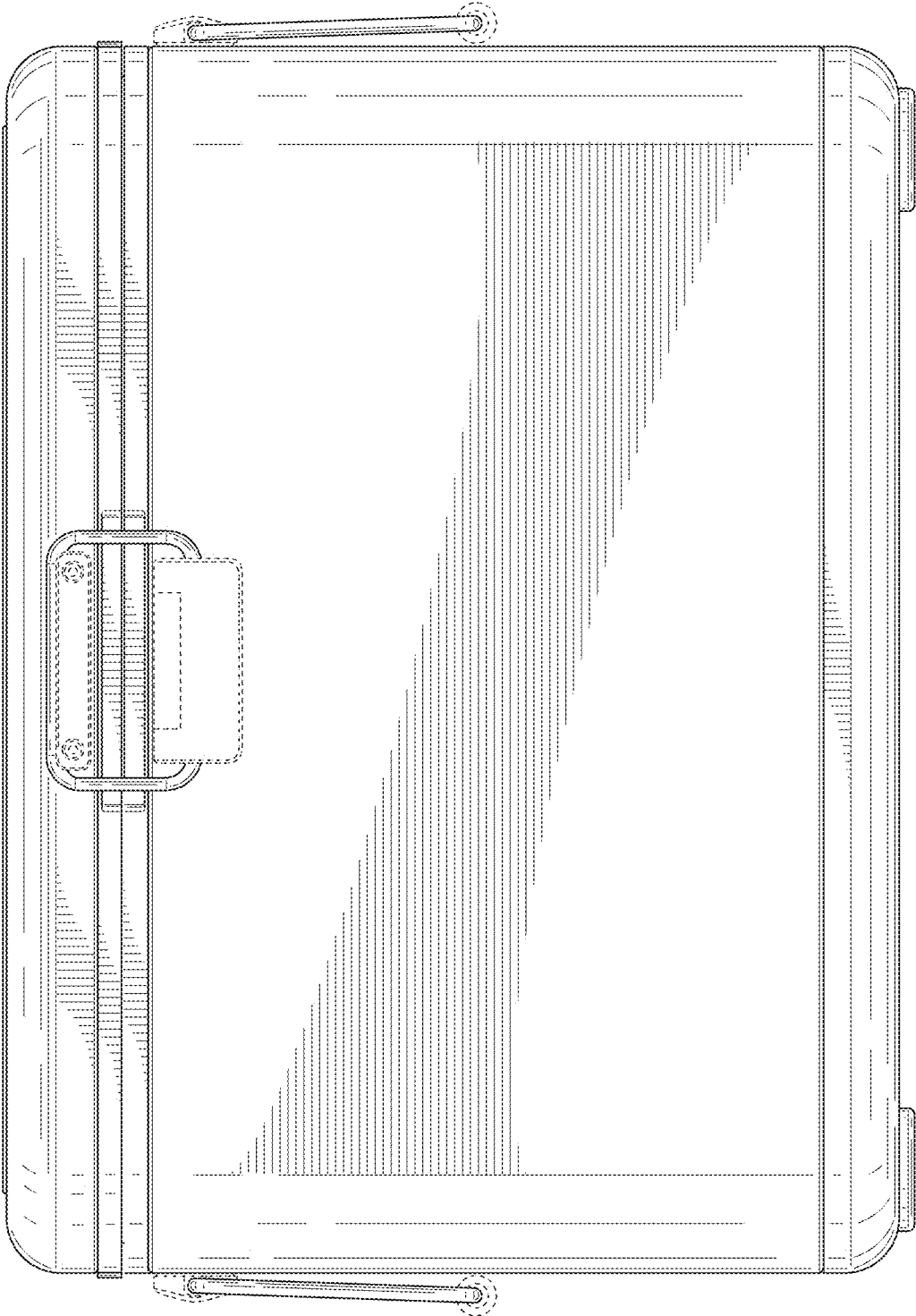

FIG. 9

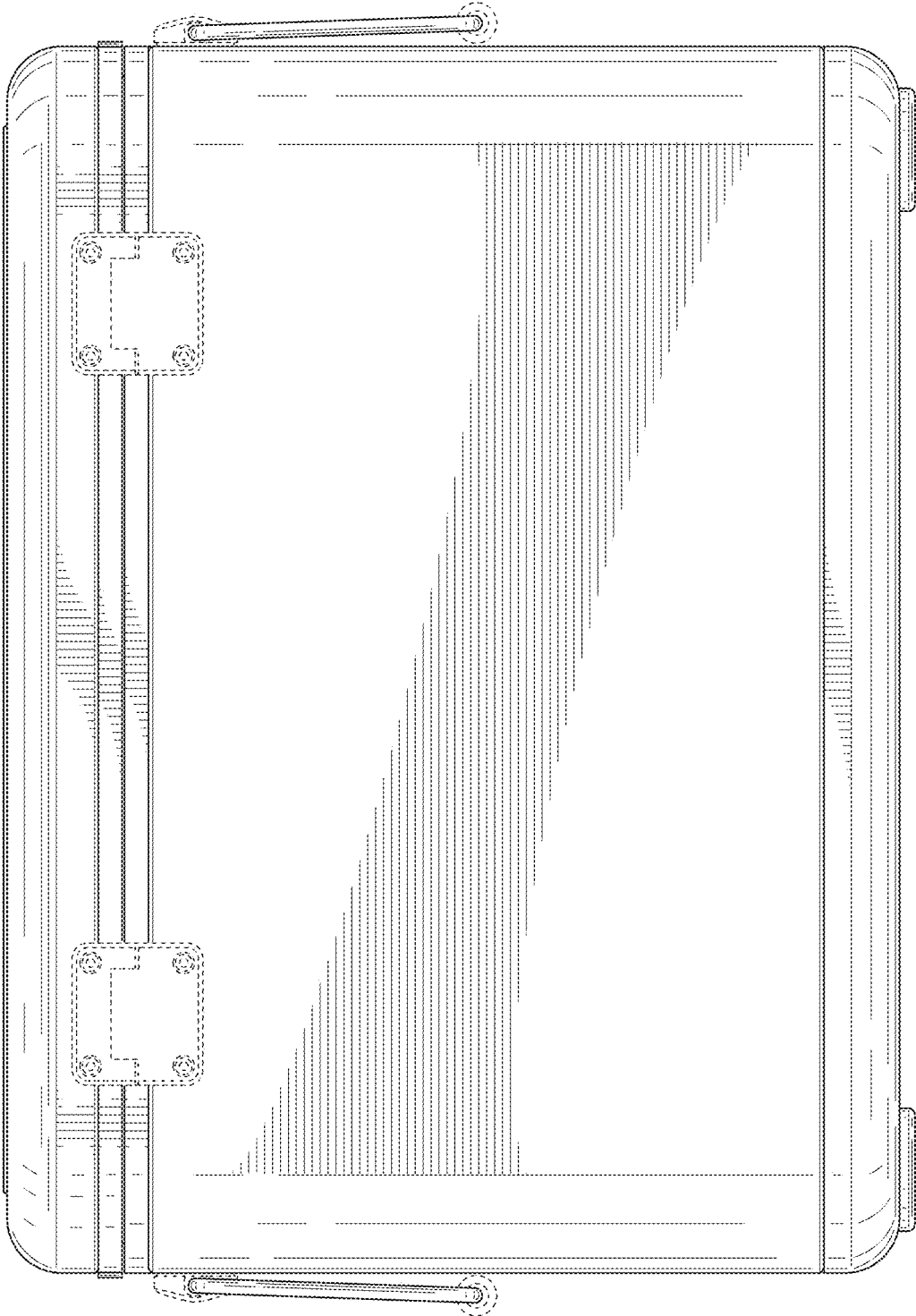

FIG. 10

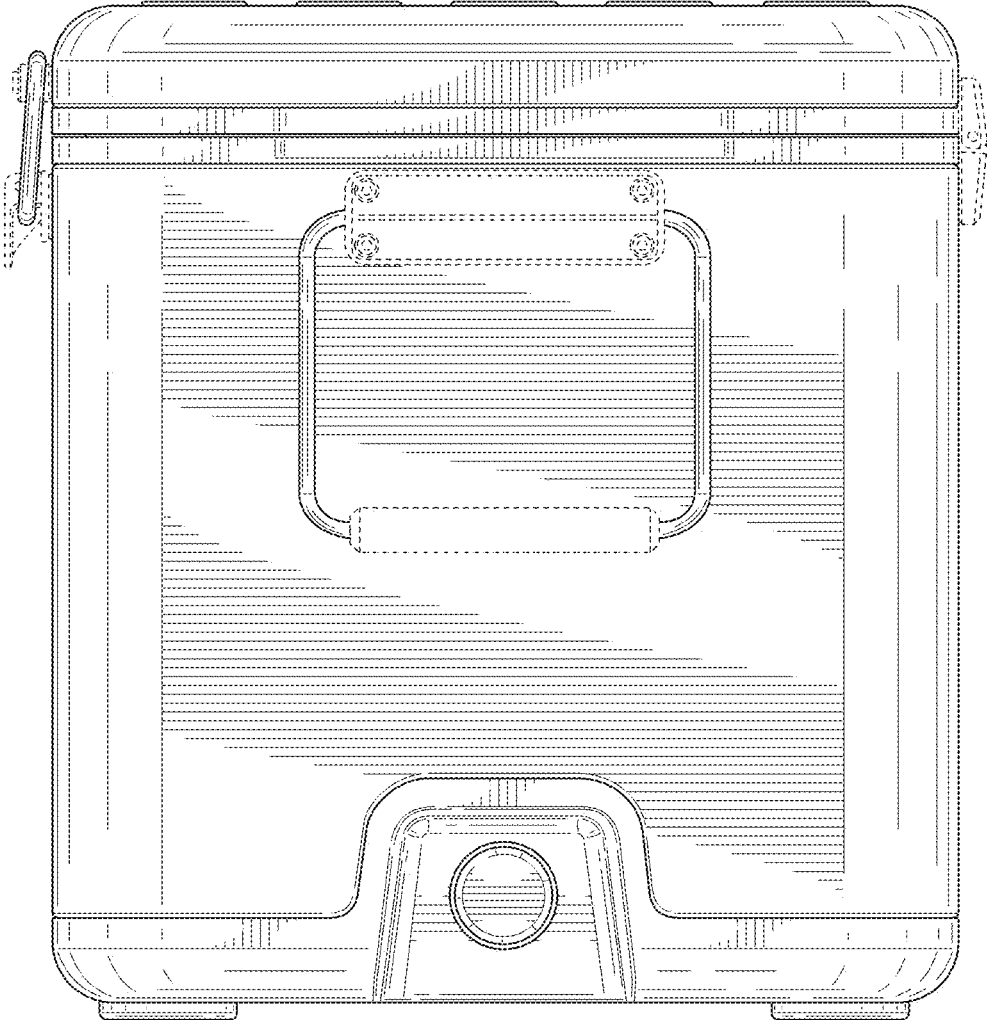

FIG. 11

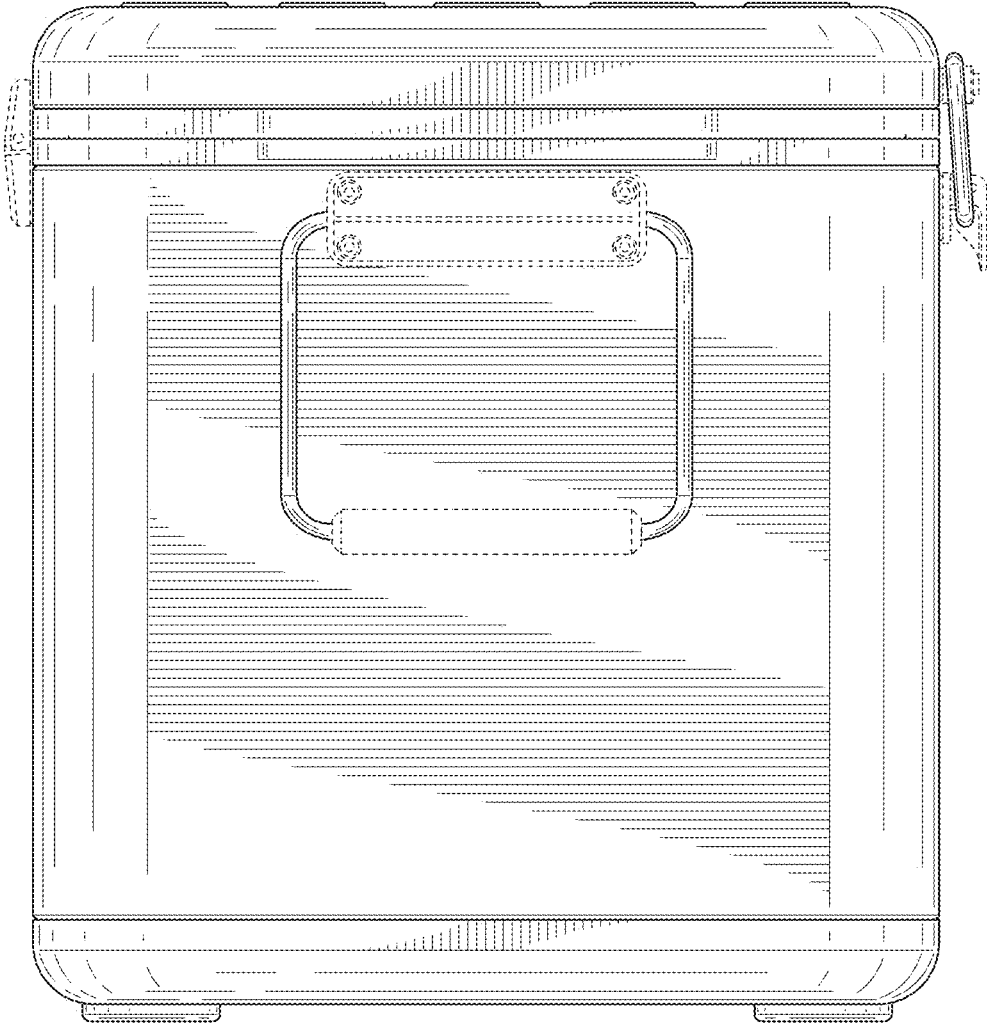

FIG. 12

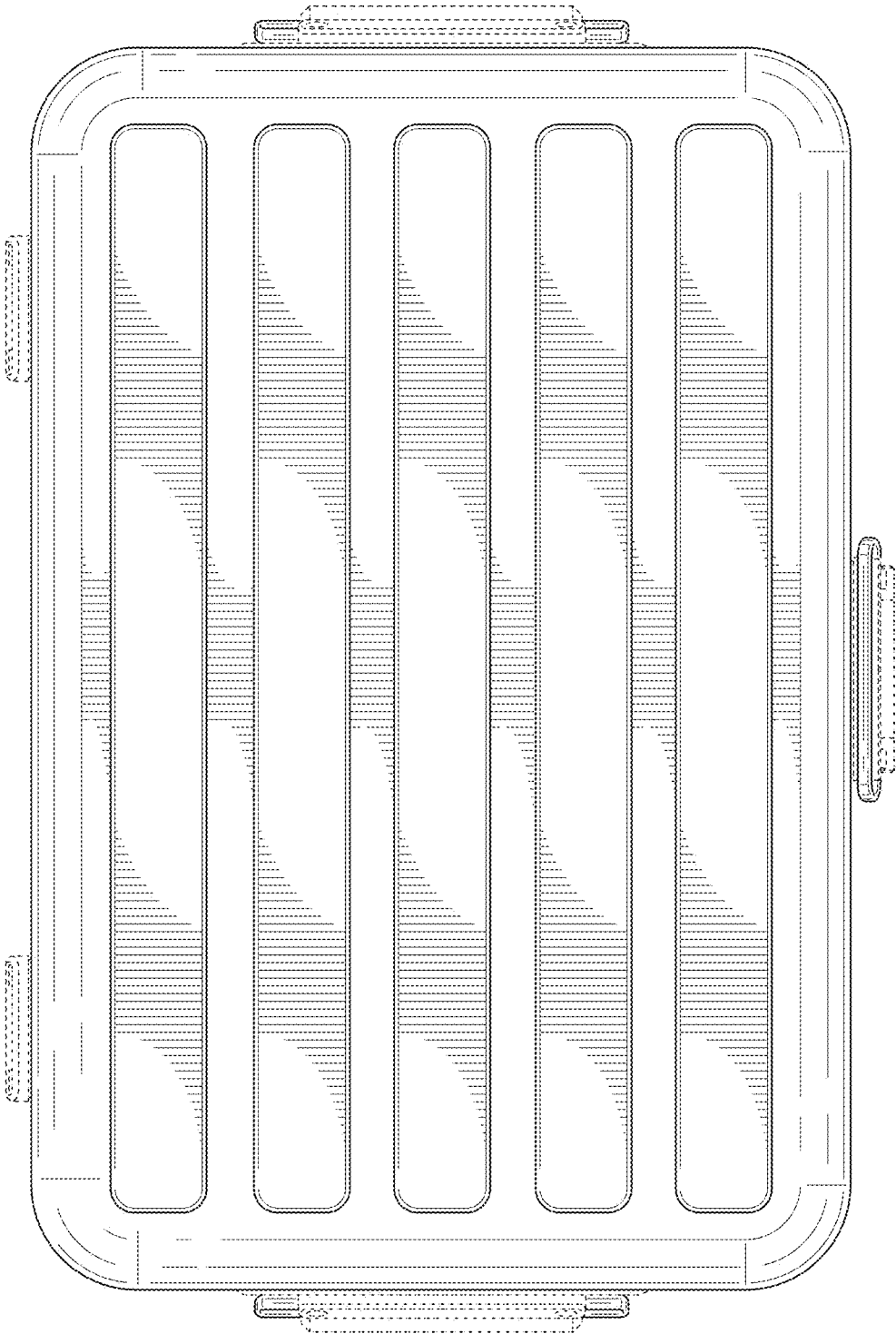

FIG. 13

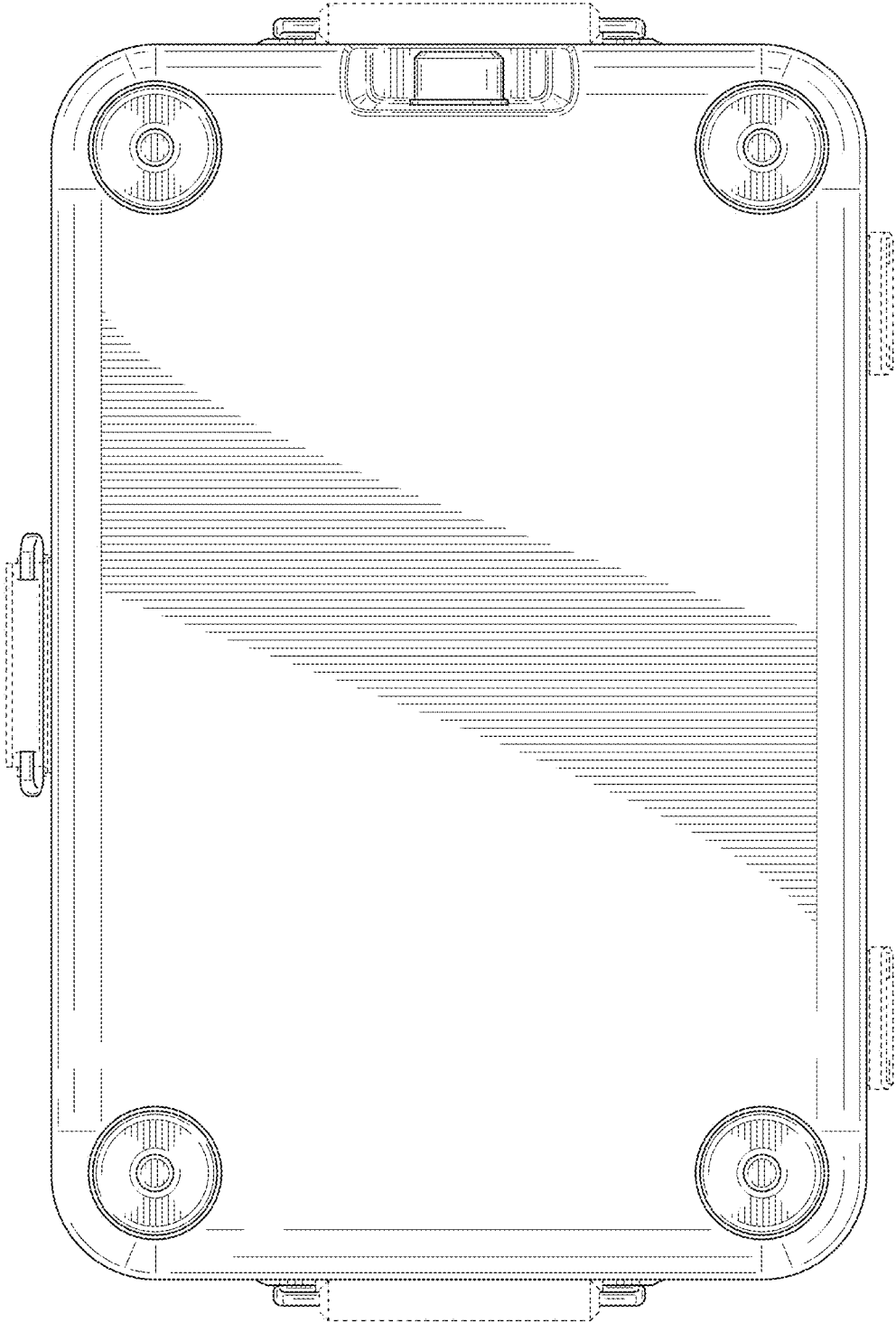

FIG. 14