

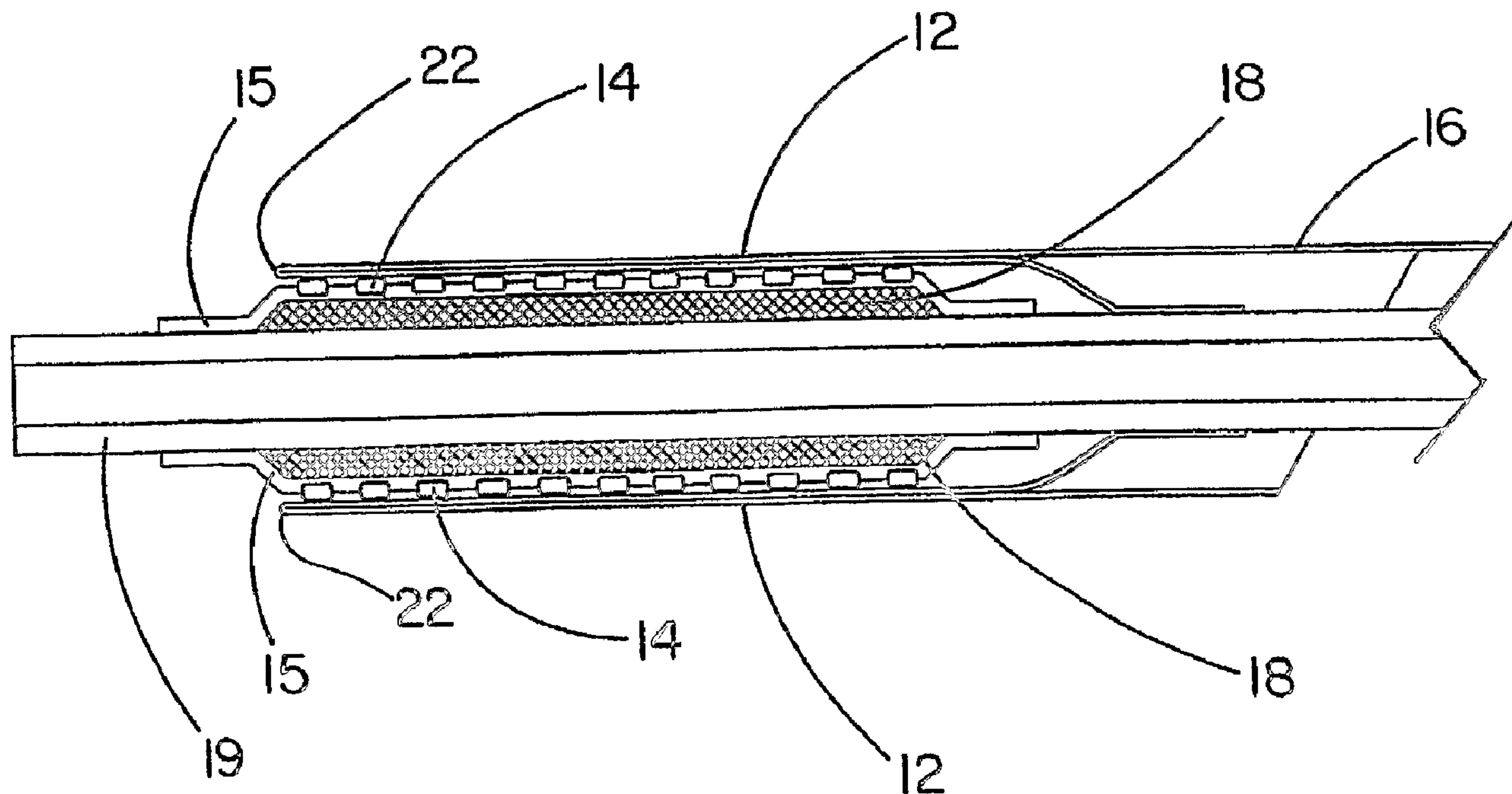

(86) Date de dépôt PCT/PCT Filing Date: 2004/01/14
 (87) Date publication PCT/PCT Publication Date: 2004/08/12
 (45) Date de délivrance/Issue Date: 2009/08/25
 (85) Entrée phase nationale/National Entry: 2005/07/14
 (86) N° demande PCT/PCT Application No.: US 2004/001046
 (87) N° publication PCT/PCT Publication No.: 2004/066809
 (30) Priorités/Priorities: 2003/01/17 (US10/346,598);
 2003/08/08 (US10/637,986)

(51) Cl.Int./Int.Cl. *A61F 2/06* (2006.01)
 (72) Inventeurs/Inventors:
 BRUUN, STEVEN R., US;
 CULLY, EDWARD H., US;
 MANN, JAMES W., US;
 ULM, MARK J., US;
 VONESH, MICHAEL J., US
 (73) Propriétaire/Owner:
 GORE ENTERPRISE HOLDINGS, INC., US
 (74) Agent: GOWLING LAFLEUR HENDERSON LLP

(54) Titre : SYSTEME DE DEPLOIEMENT D'UN DISPOSITIF ENDOLUMINAL
 (54) Title: DEPLOYMENT SYSTEM FOR AN ENDOLUMINAL DEVICE



(57) Abrégé/Abstract:

A deployment system (10) for an endoluminal device. The deployment system (10) includes a confining sheath (12) placed around a compacted endoluminal device (14, 15). A deployment line (16) is provided in the system that is an integral extension of the sheath (12). As the deployment line (16) is actuated, the sheath (12) retracts from around the compacted endoluminal device (14, 15). As the sheath (12) retracts from around the endoluminal device (14, 15), material from the sheath may be converted into deployment line (16). Once the sheath (12) is retracted from around the compacted endoluminal device (14, 15), the endoluminal device (14, 15) expands in configuration and repairs vascular or cardiac structures of an implant recipient. Any remaining sheath material (12) is removed from the implantation site along with the deployment line (16). The deployment system (10) also includes an endo-prosthesis mounting member (18) placed between the endoluminal device and an underlying catheter (19). The endo-

(57) **Abrégé(suite)/Abstract(continued):**

prosthesis mounting member (18) serves to cushion and retain the endoluminal device (14, 15) when constrained by the sheath (12) and may assist in expansion of the endoluminal device (14, 15) when unconstrained by the sheath (12).

(12) INTERNATIONAL APPLICATION PUBLISHED UNDER THE PATENT COOPERATION TREATY (PCT)

(19) World Intellectual Property
Organization
International Bureau



(43) International Publication Date
12 August 2004 (12.08.2004)

PCT

(10) International Publication Number
WO 2004/066809 A3

(51) International Patent Classification⁷: **A61F 2/06**

(21) International Application Number:
PCT/US2004/001046

(22) International Filing Date: 14 January 2004 (14.01.2004)

(25) Filing Language: English

(26) Publication Language: English

(30) Priority Data:
10/346,598 17 January 2003 (17.01.2003) US
10/637,986 8 August 2003 (08.08.2003) US

(71) Applicant (for all designated States except US): **GORE ENTERPRISE HOLDINGS, INC.** [US/US]; 555 Paper Mill Road, P.O. Box 9206, Newark, DE 19714-9206 (US).

(72) Inventors; and

(75) Inventors/Applicants (for US only): **BRUUN, Steven, R.** [US/US]; 2066 S. Tombaugh Way, Flagstaff, AZ 86001 (US). **CULLY, Edward, H.** [US/US]; 940 Sinagua Heights Drive, Flagstaff, AZ 86004 (US). **MANN, James, W.** [US/US]; 204 Wedgemont Drive, Elkton, MD 21921465 (US). **ULM, Mark, J.** [US/US]; 610 N. Apollo

Way, Flagstaff, AZ 86001 (US). **VONESH, Michael, J.** [US/US]; 3885 E. Kokopalli Lane, Flagstaff, AZ 86004 (US).

(74) Agents: **BOLAND, Kevin, J.** et al.; W.L. Gore & Associates, Inc., 551 Paper Mill Road, P.O. Box 9206, Newark, DE 19714-9206 (US).

(81) Designated States (unless otherwise indicated, for every kind of national protection available): AE, AG, AL, AM, AT, AU, AZ, BA, BB, BG, BR, BW, BY, BZ, CA, CH, CN, CO, CR, CU, CZ, DE, DK, DM, DZ, EC, EE, EG, ES, FI, GB, GD, GE, GH, GM, HR, HU, ID, IL, IN, IS, JP, KE, KG, KP, KR, KZ, LC, LK, LR, LS, LT, LU, LV, MA, MD, MG, MK, MN, MW, MX, MZ, NA, NI, NO, NZ, OM, PG, PH, PL, PT, RO, RU, SC, SD, SE, SG, SK, SL, SY, TJ, TM, TN, TR, TT, TZ, UA, UG, US, UZ, VC, VN, YU, ZA, ZM, ZW.

(84) Designated States (unless otherwise indicated, for every kind of regional protection available): ARIPO (BW, GH, GM, KE, LS, MW, MZ, SD, SL, SZ, TZ, UG, ZM, ZW), Eurasian (AM, AZ, BY, KG, KZ, MD, RU, TJ, TM), European (AT, BE, BG, CH, CY, CZ, DE, DK, EE, ES, FI, FR,

[Continued on next page]

(54) Title: DEPLOYMENT SYSTEM FOR AN ENDOLUMINAL DEVICE

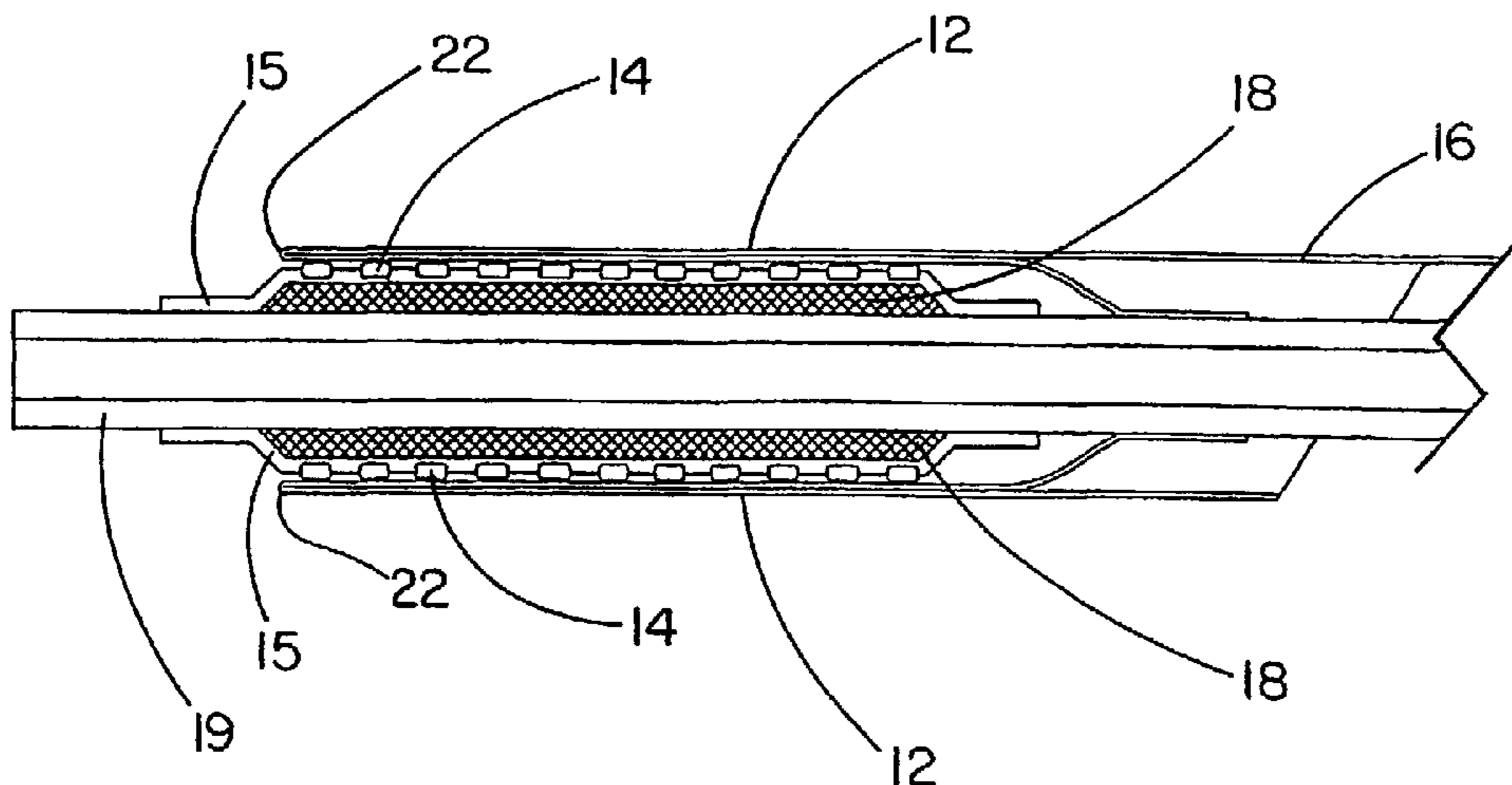

(57) Abstract: A deployment system (10) for an endoluminal device. The deployment system (10) includes a confining sheath (12) placed around a compacted endoluminal device (14, 15). A deployment line (16) is provided in the system that is an integral extension of the sheath (12). As the deployment line (16) is actuated, the sheath (12) retracts from around the compacted endoluminal device (14, 15). As the sheath (12) retracts from around the endoluminal device (14, 15), material from the sheath may be converted into deployment line (16). Once the sheath (12) is retracted from around the compacted endoluminal device (14, 15), the endoluminal device (14, 15) expands in configuration and repairs vascular or cardiac structures of an implant recipient. Any remaining sheath material (12) is removed from the implantation site along with the deployment line (16). The deployment system (10) also includes an endo-prosthesis mounting member (18) placed between the endoluminal device and an underlying catheter (19). The endo-prosthesis mounting member (18) serves to cushion and retain the endoluminal device (14, 15) when constrained by the sheath (12) and may assist in expansion of the endoluminal device (14, 15) when unconstrained by the sheath (12).

WO 2004/066809 A3

WO 2004/066809 A3



GB, GR, HU, IE, IT, LU, MC, NL, PT, RO, SE, SI, SK, TR), OAPI (BF, BJ, CF, CG, CI, CM, GA, GN, GQ, GW, ML, MR, NE, SN, TD, TG).

(88) Date of publication of the international search report:
23 December 2004

Published:

- *with international search report*
- *before the expiration of the time limit for amending the claims and to be republished in the event of receipt of amendments*

For two-letter codes and other abbreviations, refer to the "Guidance Notes on Codes and Abbreviations" appearing at the beginning of each regular issue of the PCT Gazette.

TITLE OF THE INVENTION**DEPLOYMENT SYSTEM FOR AN ENDOLUMINAL DEVICE**

5

10

FIELD OF THE INVENTION

The present invention relates generally to implantable medical device assemblies. In particular, the invention relates to means for deploying an endoluminal device within vascular or cardiac structures of an implant recipient.

15

BACKGROUND OF THE INVENTION

Various implantable medical devices for repairing or reinforcing cardiac and vascular structures have been developed in recent years. Some of these devices can be implanted inside a particular vascular or cardiac structure through so-called interventional, or endovascular, techniques. Interventional techniques involve surgically accessing the vascular system through a conveniently located artery or vein and introducing distal portions of a medical device assembly into the vascular system through the arterial or venous access point. Once the medical device assembly is introduced into the vascular system, it is threaded through the vasculature to an implantation site while proximal portions of the assembly having manually operated control means remain outside the body of the implant recipient. The medical device component of the assembly is then deposited at the implantation site and the remainder of the distal portion of the medical device assembly removed from the vascular system through the access point.

30

35

Exemplary interventional medical device assemblies include a catheter. The catheter can be used to precisely position the medical device at an implantation site as well as participate in deployment of the medical device at the implantation site. Some catheters have guidewires running their length to aid in positioning and deployment of the medical device. As an alternative to the guidewire, a catheter may be coaxial with an inner sleeve running inside the length of the catheter. The inner sleeve is used to hold an implantable medical device in position while the outer catheter is pulled, causing deployment of the

device. Handles, knobs, or other manually operated control means are attached to the opposite end of the catheter in this assembly.

Some implantable medical devices, such as stents, stent-grafts, or other endoluminal devices often require reconfiguration from an initial compacted form to an expanded
5 cylindrical configuration as the device is deployed at an implantation site. These devices can expand on their own by virtue of the design and composition of their structural elements or through the use of an inflatable balloon placed inside the devices.

Self-expanding endoluminal medical devices are maintained in a compacted configuration in a variety of ways. Some devices are maintained in a compacted
10 configuration by simply confining the compacted devices inside a catheter, or similar tool. Other devices are placed inside a sheath following compaction. In these assemblies, a control line is often used to assist in releasing the endoluminal device from the sheath.

In U.S. Patent No. 6,352,561, issued to Leopold et al., a sheath is formed around an expandable endoluminal device and a control line used to maintain the sheath around the
15 endoluminal device. The sheath is formed by folding a length of polymeric material in half and stitching the opposing edges together with the control line. The stitching pattern permits the control line to be removed from the sheath by pulling on a proximal end of the control line. As the control line becomes unstitched from the sheath, the endoluminal device is progressively released from confinement within the sheath. The control line is removed from
20 the assembly as a distinct entity while the sheath remains at the implantation site.

In U.S. Patent No. 5,647,857, issued to Anderson et al., an endoluminal device is held in a collapsed configuration over a catheter by a sheath. The assembly is provided with a control line having a free end and an end attached to a collar component of the catheter. The sheath is removed from the endoluminal device by pulling on the control line. As the
25 control line is pulled, it cuts through and splits the sheath material from distal end to proximal end. As the sheath splits open, the endoluminal device is freed to expand. Unlike Leopold et al., the control line remains mechanically attached to the sheath and catheter assembly following deployment of the endoluminal device.

In U.S. Patent No. 6,447,540, issued to Fontaine et al., a confining sheath is
30 removed from around an endoluminal device with a control line that cuts through and splits the sheath material when pulled by a practitioner, much like Anderson et al. As with Leopold et al, the control line can be completely removed from the assembly as a distinct entity.

In U.S. Patent No. 5,534,007, issued to St. Germain et al., a single-walled sheath that can collapse and shorten along its length is placed around a stent. As the distal portion
35 of the sheath is retracted, it uncovers the stent. The uncovered stent is free to expand. A

control line can be used to exert a pulling force on the collapsible sheath as a means of removing the sheath from the stent. The control line remains attached to the sheath during and subsequent to deployment of the stent.

5 In U.S. Patent No. 6,059,813, issued to Vrba et al, a double-walled confinement sheath for an endoluminal device is described. In an assembly made of these components, the endoluminal device is placed over a catheter shaft in a collapsed configuration. An outer tube is placed in slidable relationship over the catheter. The distal end of the outer tube does not extend to cover the endoluminal device. Rather, the double walled sheath is placed over the collapsed endoluminal device. The inner wall of the sheath is attached to
10 the catheter shaft near the proximal end of the endoluminal device. The outer wall of the double-walled sheath is mechanically attached to the outer tube. Movement of the outer tube relative to the catheter causes the outer wall of the sheath to move past the inner wall of the sheath. Movement of the outer tube in the proximal direction causes the sheath to retract and uncover the underlying endoluminal device. As the sheath retracts, the
15 endoluminal device becomes free to expand. A control line is mechanically attached to the outer tube and serves to move the outer tube and retract the sheath.

None of these medical device assemblies utilize a control line that is integral with a confining sheath. Nor do these assemblies feature a sheath that is convertible to a control line as the sheath is removed from around the endoluminal device. Such an integral control
20 line and confining sheath would preferably be made of a continuous thin-walled material or composite thereof. The thin-walled material would be flexible and exert minimal restrictions on the flexibility of an underlying endoluminal device. Thin-walled materials would also reduce the profile of the sheath and endoluminal device combination. An integral control line and confining sheath would simplify manufacture of control line - sheath constructs by
25 eliminating the need to mechanically attach the control line to the sheath. An integral control line and confining sheath would also eliminate concerns regarding the reliability of the mechanical attachment of the control line to the sheath. Additionally, inclusion of materials, composites, constructions, and/or assemblies exhibiting compliance, compressibility, resilience, and/or expandability when positioned between the sheath-constrained
30 endoluminal device and the delivery catheter would serve to cushion and retain the endoluminal device beneath the confining sheath on a delivery catheter, as well as assist in expansion of the endoluminal device in some embodiments.

SUMMARY OF THE INVENTION

The present invention is directed to a deployment system for an endoluminal or endo-prosthetic device. In preferred embodiments, the endoluminal device is self-expanding as a consequence of the device design and the materials used to construct the device. In other embodiments, the endoluminal device is expandable with an inflatable balloon or other dilation means placed within the device. In yet other embodiments, the endoluminal device is an inflatable balloon. The endoluminal device is maintained in a compacted, or collapsed, configuration by a removable sheath. In preferred embodiments, the removable sheath is removed from around the endoluminal device by applying tension to a deployment line. The deployment line is an integral, continuous, extension of the sheath and is made of the same material as the sheath. As the deployment line is pulled, the sheath is progressively removed from around the endoluminal device and also functions as an extension of the deployment line. When the sheath has been substantially removed from around a portion of the endoluminal device, that portion of the endoluminal device is free to expand. Removal of the sheath may be continued until the entire endoluminal device is freed from radial constraint. The deployment line, along with any remaining sheath material, may be removed from the implantation site through a catheter used to deliver the sheathed endoluminal device to the site.

In embodiments employing an endoluminal device in the form of a stent, the sheath may be removed from around the stent by inflating a balloon or other dilation means located within the collapsed lumen of the stent and expanding the stent against the sheath until the sheath is removed through the action of an indwelling balloon or other dilation means. The sheath is removed with the aid of the deployment line portion of the present invention and/or a mechanism capable of storing and releasing kinetic energy. As seen in Figure 13, the mechanism is referred to herein as an "active elastic element (25)" and is preferably in the form of spring elements incorporated into the deployment line portion and/or the sheath portion of the present invention. Alternatively, active elastic elements can be in the form of rubber bands and elastomeric polymers, including fluoroelastomers.

The removable sheath is made of one or more thin, flexible polymeric materials including composites thereof. The sheath ordinarily assumes the form of a continuous thin-walled tube when constraining an endoluminal device. Such a thin-walled sheath exerts minimal resistance to longitudinal flexing of the underlying endoluminal device. The thin-walled sheath also reduces the profile of the sheath – endoluminal device combination, when compared to conventional constraints. In preferred embodiments, a double-walled tubular sheath is used. Double walls enable the sheath to be retracted from around an endoluminal device by sliding one wall past the other wall. As the sheath is retracted, or

unrolled, in this manner, the sheath portion does not rub or scrape against the underlying endoluminal device. This is particularly advantageous when coatings containing medications, and/or pharmaceuticals are placed on surfaces of the endoluminal device that could be disrupted by a sheath that rubs or scrapes against the endoluminal device as the sheath is removed from the device.

The deployment line is formed from the same material as the removable sheath and is an integral extension of the sheath material. In some embodiments, the deployment line portion (16) extends from the sheath portion (12, 12a) through a delivery catheter to a control knob (not shown) located at the proximal end of the catheter (Figs. 3-7). Among these embodiments, the sheath portion extends proximally beyond the endoluminal device toward the distal end of the deployment system (Fig. 5). In preferred embodiments, the sheath extends over the underlying delivery catheter a desired length to a point at which the sheath portion transforms to the deployment line portion (Fig. 7). In more preferred embodiments, the sheath portion extends substantially the entire length of the delivery catheter before transforming into deployment line. In the most preferred embodiment (Fig. 11), at least a portion of the sheath – deployment line construction (12) is enclosed within a secondary catheter (19a), catheter lumen, or other containment device such as an expanded porous polytetrafluoroethylene tube. Pulling on the control knob actuates the deployment line. Once the deployment line is actuated, the removable sheath begins to move, or retract, from around the endoluminal device.

In one embodiment, as removed sheath material travels beyond the receding end of the sheath, the sheath begins to become converted to deployment line. Conversion of the sheath into the deployment line usually begins at a point where the tubular sheath breaks apart, separates, and converges into deployment line material. In preferred embodiments, means are provided for initiating or sustaining the conversion of the sheath to deployment line. These means may take the form of perforations, stress risers, or other mechanical weaknesses introduced into the sheath material. The means can also be cutting edges or sharp surfaces on the delivery catheter.

In preferred embodiments, materials, composites, constructions, and/or assemblies exhibiting compliance, compressibility, resilience, and/or expandability are placed between the endo-prosthesis, or endoluminal device, and the delivery catheter to provide an “endo-prosthesis mounting member.” An endo-prosthesis mounting member serves to cushion the endoluminal device when constrained by the sheath and may assist in expansion of the device when unconstrained. An endo-prosthesis mounting member also serves to anchor and retain the endoluminal device in place around an underlying catheter shaft, while minimizing the profile of the deployment system. Anchoring the endoluminal device with an

endo-prosthesis mounting member eliminates the need for barrier, or retention, means at either end of the endoluminal device. The absence of barrier means contributes to a reduction in the profile of the deployment system as well as increasing the flexibility of the distal portion of the system. The present invention can also be provided with an additional
5 catheter or catheter lumen for the sheath – deployment line in order to prevent the deployment line portion from leaving the general path established by the delivery catheter. In one embodiment, the endo-prosthesis mounting member is in the form of an inflatable, or otherwise expandable, balloon. The present invention can be used alone or in combination with other endo-prosthesis delivery means. Multiple endo-prosthetic devices can also be
10 delivered with the present invention.

Accordingly, one embodiment of the present invention is a deployment system for an endoluminal device comprising an expandable endoluminal device mounted on a delivery catheter provided with an endo-prosthesis mounting member, a removable sheath adapted to cover the endoluminal device, the sheath comprising a fluoropolymer material adapted to surround at least a portion of the endoluminal device and constrain the device in an introductory profile, wherein the deployment system includes a deployment line integral with the sheath to effectuate device deployment, and wherein upon deployment, the sheath separates from the endoluminal device through actuation of the deployment line, the sheath becoming removed from the device along with the deployment line.

In another embodiment, the present invention is a deployment system for an endoluminal device comprising an expandable endoluminal device placed over an endo-prosthesis mounting member and at least partially enclosed by a removable sheath, and a deployment line integral with the removable sheath, wherein the removable sheath is convertible to the deployment line as the sheath is removed from the endoluminal device.

These enhanced features and other attributes of the deployment system of the present invention are better understood through review of the following specification.

BRIEF DESCRIPTION OF THE DRAWINGS

Figure 1 illustrates a longitudinal cross-section of the present invention.

15 Figure 1A is an enlarged view of Figure 1.

Figure 2 illustrates a perspective view of the present invention.

Figure 3 illustrates a longitudinal cross-section of the present invention.

Figure 3A is an enlarged view of Figure 3.

Figure 4 illustrates a longitudinal cross-section of the present invention.

20 Figure 4A is an enlarged view of Figure 4.

Figure 5 illustrates a longitudinal cross-section of the present invention.

Figure 5A is an enlarged view of Figure 5.

Figure 6 illustrates a longitudinal cross-section of the present invention.

Figure 6A is an enlarged view of Figure 6.

5 Figure 7 illustrates a longitudinal cross-section of the present invention.

Figure 7A is an enlarged view of Figure 7.

Figure 7B illustrates the embodiment of Figure 7A as viewed from the direction indicated by the arrow.

10 Figure 7C illustrates the embodiment of Figure 7A as viewed from the direction indicated by the arrow.

Figures 8 and 8A illustrate longitudinal cross-sections views of the present invention placed inside a vascular or cardiac structure.

Figure 9 illustrates a longitudinal cross-section of the present invention with a covering placed over an endo-prosthesis mounting member.

15 Figure 9A illustrates a longitudinal cross-section of the present invention without a covering placed over an endo-prosthesis mounting member.

Figure 10 illustrates a longitudinal cross-section of the present invention with an endo-prosthesis mounting member placed between an underlying delivery catheter and an endoluminal device.

20 Figure 11 illustrates a longitudinal cross-section of the present invention having an outer catheter, or tube, placed over substantially the entire length of a sheath – deployment line construction.

25 Figure 12 illustrates a longitudinal cross-section of the present invention showing an endoluminal device in the form of a collapsed inflatable balloon having a first dimension confined to a second dimension with a sheath – deployment line of the invention.

Figure 13 illustrates a cross-section of the present invention showing an active elastic element attached to the sheath portion of the present invention as a means to remove the sheath from around an endoluminal device.

30

DETAILED DESCRIPTION OF THE INVENTION

The present invention is directed to a deployment system for an endoluminal device having a removable sheath with a deployment line or filament that is an integral part of the sheath. As indicated by the relative difference in the space between the “x” arrows and the “y” arrows in Figure 12, the sheath portion (12) confines the endoluminal device (18a) to a smaller profile than is possible without the sheath. The sheath radially confines the endoluminal device in a compacted or collapsed configuration during storage and

introduction into a patient's vascular system. The confining sheath maintains the endoluminal device in a compacted configuration until the device is delivered with a catheter to an implantation site in a vascular or cardiac structure. At the time of deployment, the sheath is retracted from the endoluminal device. In some embodiments, sheath material
5 may be converted into deployment line material as the sheath is removed from the endoluminal device. As the sheath is removed from the endoluminal device, the endoluminal device is free to expand. Once free from the confining sheath, the endoluminal device may expand spontaneously or with the assistance of an inflatable balloon. Any remaining sheath material may be removed from the implantation site along with the
10 deployment line.

The integral sheath – deployment line is preferably a flexible polymeric material that is continuous along the length of the construct. Preferably, the physical and mechanical properties of the sheath portion are such that they are uniform and homogeneous throughout the length of the sheath portion used to constrain the endoluminal device. Since most
15 endoluminal devices are generally circularly cylindrical in form, the sheath is preferably tubular in shape in order to enclose most or all of the endoluminal device. Conical, tapered, or other suitable shapes for the sheath are also contemplated in the present invention. Flexibility of the sheath is enhanced by making the walls of the sheath as thin as practicable. In one embodiment of the present invention (20), the tubular sheath portion (12a) of the
20 sheath – deployment line has a single wall (Fig. 3). The deployment line portion can extend from either end of the single-walled sheath (12a). When the sheath portion is retracted from around an endoluminal device, the length of retracted sheath is substantially equal to the length of deployment line displaced during deployment of the endoluminal device.

In another embodiment of the present invention (10), the sheath portion (12) of the
25 sheath – deployment line has a double wall (Figs. 1, 2, and 4 - 11). In a preferred embodiment, the double walled-sheath portion (12) is made of a polymeric material that is folded on itself. The double-walled sheath portion is placed over the endoluminal device (14) so that the fold (22) is positioned at the distal end (*i.e.*, farthest from the control knob) of the sheath portion (12). The inner wall of the sheath portion may be anchored to part of an
30 underlying delivery catheter (19) proximal to the endoluminal device (14). In preferred embodiments, the sheath portion (12) is not attached to the delivery catheter (19). The proximal end of the outer wall of the sheath has at least one portion, or integral extension, that is convertible to deployment line (16). Space between the walls of the double-walled sheath portion can be filled with fluids, lubricants, pharmaceutical compositions, and/or
35 combinations thereof. The deployment line (16) is routed through the delivery catheter (19) to a control knob (not shown) located at the proximal end of the deployment system (10). Alternatively, a separate catheter (13) or catheter lumen (11) is provided for the deployment

line (Figs 4 and 1, respectively). These embodiments provide additional containment of the deployment line portion, particularly when bends or curves in a patient's vasculature having small radii are anticipated. In the most preferred embodiment (Fig. 11), the sheath portion of the sheath – deployment line construction extends substantially the entire length of the delivery catheter (19) and is confined within a separate catheter (19a) or catheter lumen. The deployment line portion is formed near the proximal end of the deployment system and is attached to a control knob (not shown).

Preferably, the physical and mechanical properties of the sheath portion are such that they are uniform and homogeneous throughout the length of the sheath portion used to constrain the endoluminal device. When the sheath portion is retracted from around an endoluminal device, the length of retracted sheath is essentially half the length of deployment line displaced during deployment of the endoluminal device. This two to one ratio of length of deployment line removed to length of sheath material removed reduces the effect of too rapid or strong a pull on the deployment line on release of the endoluminal device from the sheath.

Fluoropolymer materials are preferred for making the retractable tubular constraining sheath – deployment line constructs of the present invention. Fluoropolymer materials used in the present invention are strong, thin, and lubricious. The lubriciousness of the fluoropolymer materials is especially advantageous in embodiments utilizing a sheath – deployment line having walls that slide past one another or over an endoluminal device. Particularly preferred fluoropolymer materials are porous expanded polytetrafluoroethylene materials alone or in combination with fluorinated ethylene propylene materials. Most preferred fluoropolymer materials are strong and thin, such as those described in Example 2, *infra*. The sheath – deployment line is made by constructing an appropriate tube from layers of film and/or membrane. The sheath-deployment line may also be constructed from extrusions of polymeric materials. The extrusions can be used alone or in combination with film/membrane materials. Once constructed, a significant portion of the tube is rendered filamentous by rolling and heating.

The sheath may be converted to deployment line by pulling on the deployment line and causing the sheath material to separate and converge into a single filament. As sheath material is converted to deployment line by this process, the edge of the sheath supplying material to the deployment line recedes causing the sheath to retract from around the endoluminal device. As a portion of the sheath retracts, the portion of the endoluminal device confined by the sheath is freed to expand (Figs 8 – 8A). Means are optionally provided to the deployment system that initiate or sustain the conversion of sheath to deployment line. As shown in Figure 7, the means include perforations (71), cutouts (72), or other engineered defect introduced into the sheath material. As shown in Figure 5, the

means also include cutters (21) or other sharp edges on the delivery catheter. Such cutting means may be formed on the delivery catheter by exposing a strand of reinforcing stainless steel from within the catheter and adapting the strand to cut into the sheath portion.

In the preferred embodiment of the present invention, materials, composites, constructions, and/or assemblies exhibiting compliance, compressibility, resilience, and/or expandability are placed between the endoluminal device and the delivery catheter to form an "endo-prosthesis mounting member (18)." The endo-prosthesis mounting member can be covered (15) or uncovered (Fig. 9). At least a portion of the endoluminal device is pressed into a covered or uncovered endo-prosthesis mounting member to anchor the endoluminal device on the delivery catheter and prevent the endoluminal device from moving along the length of the catheter. Materials with a tacky surface are useful with the endo-prosthesis mounting member, particularly in combination with a lubricious sheath material. The endo-prosthesis mounting member eliminates the need for barrier, or retention, means placed at the proximal and distal end of the endoluminal device. In addition to added flexibility imparted to the deployment system without the barrier means, the profile of the sheath and endoluminal device combination is reduced without the barrier means. In yet another embodiment, the endo-prosthesis mounting member is in the form of an inflatable balloon (Fig 10, part 18a). Suitable materials for the endo-prosthesis mounting member include, but are not limited to, silicones, silicone foams, polyurethane, polyurethane foams, and polytetrafluoroethylene foams or combinations thereof. The endo-prosthesis mounting member is attached to the outer wall of the delivery catheter with adhesives, heat, or other suitable means.

A non-inflatable endo-prosthesis mounting member is preferably enclosed with a covering (15) in the form of a polymeric material. The polymeric material is preferably a fluoropolymer-based material. Porous expanded polytetrafluoroethylene is the preferred fluoropolymer for enclosing the compressible material. Other suitable polymeric materials include, but are not limited to, silicone, polyurethane, polyester, and the like.

Examples

30

Example 1

This example describes the construction of a deployment system of the present invention. Construction of the system began with the preparation of a distal catheter shaft for receiving an expandable stent. Once the distal catheter was prepared, the expandable stent was placed within a sheath – deployment line. The distal catheter portion of this combination was attached to a primary catheter shaft. The deployment line portion was then

routed through the primary catheter to a control knob. The control knob was part of a hub located proximally on the primary catheter. The sheath portion of the sheath – deployment line was in the form of a single-walled tube.

5 A tubular material three inches long was obtained from Burnham Polymeric, Inc., Glens Falls, NY for use as the distal catheter shaft. The tube was made of a polyether block amide material, commonly known as PEBAX® resin and reinforced with a stainless steel braid. The outer diameter (OD) was 1.01mm and the inner diameter (ID) was 0.76mm. An endo-prosthesis mounting member in the form of a compressible material was then placed on the catheter.

10 To place the endo-prosthesis mounting member on the catheter, the catheter was mounted on a mandrel having an outer diameter of 0.74mm. A film of porous expanded polytetrafluoroethylene (ePTFE) was obtained according to the teachings in U.S. Patent No. 5,814,405, issued to Branca. A discontinuous coating of fluorinated ethylene propylene (FEP) was applied to one side of the ePTFE material in accordance with U.S. Patent No. 15 6,159,565, issued to Campbell et al. An edge of the ePTFE – FEP composite film two inches wide was attached with heat to the catheter shaft. After initial attachment, the film was wrapped around the catheter shaft forty-five (45) times under light tension. With every fifth wrap of the film, and on the final layer, the film is further attached to itself with heat supplied by a soldering iron.

20

This procedure provided a endo-prosthesis mounting member in the form of a compressible material, or compliant “pillow,” on the distal catheter shaft. The expandable stent was mounted over the endo-prosthesis mounting member. The endo-prosthesis mounting member provides a means of retaining an expandable stent on the catheter shaft 25 during storage, delivery to an implantation site, and deployment of the expandable stent at the implantation site. Optionally, the endo-prosthesis mounting member may be reinforced with a thin coating of an elastomeric material such as silicone, urethane, and/or a fluoroelastomer.

30 An eight (8) cell, 6mm diameter, nitinol stent was obtained from Medinol Ltd., Tel-Aviv, Israel. The stent was placed over the endo-prosthesis mounting member of the catheter in an expanded state. The combination was placed within a machine having a mechanical iris that compacts or compresses the stent portion of the assembly onto the endo-prosthesis mounting member. While retained in the mechanical iris machine, the stent was reduced in temperature from room temperature (c. 22°C) to approximately five degrees 35 centigrade (5°C). At the reduced temperature, the iris machine was actuated to compact, or collapse, the stent onto the endo-prosthesis mounting member. While in the refrigerated

and compressed configuration, the catheter, endo-prosthesis mounting member, and stent were placed within a sheath – deployment line of the present invention.

The sheath – deployment line having a length equal to, or greater than, the length of the final deployment system was made as follows. A length of stainless steel mandrel (c. 5 1m) measuring 1.89mm in diameter was covered with a tubular extruded ePTFE material having an overall length of about 200cm. The tubular ePTFE material had an outer diameter of 1.41mm, a wall thickness of 0.05mm, and an average longitudinal tensile strength of 3.52kgf with an average circumferential strength of 0.169kgf. The tubular ePTFE material also had an average mass/length of 0.0473g/ft with an average Matrix Tensile Strength of 10 69,125 PSI. At one end (proximal end), the tubular ePTFE material was bunched together on the mandrel, while the opposite end (distal end) of the ePTFE material remained smooth on the mandrel.

The first few centimeters of the tubular ePTFE material was sacrificed and the next 5cm of the distal end (smoothed end) of the extruded ePTFE material was then reinforced 15 with a composite fluoropolymer material as follows. The ePTFE-covered mandrel was attached to retaining chucks on a film-wrapping machine. A first reference line located approximately 5cm from the end of the smooth portion of the extruded ePTFE material was circumferentially drawn around the material with a permanent marker (SHARPIE®). A 5cm wide composite membrane made of expanded polytetrafluoroethylene (ePTFE) and 20 fluorinated ethylene propylene (FEP) was applied proximal from the first reference line on the extruded ePTFE material so the FEP portion of the composite membrane was against the extruded ePTFE material. The composite membrane was wrapped around the ePTFE covered mandrel two times so that the primary strength of the extruded ePTFE material was oriented perpendicular to the longitudinal axis of the mandrel. The composite membrane 25 was initially tacked in place on the extruded ePTFE material with heat applied from a soldering iron. The composite ePTFE/FEP material had a density of about 2.14g/cm³, a thickness of 0.005mm, and tensile strengths of about 340 KPa (about 49,000 psi) in a first direction and of about 120 KPa (about 17,000 psi) in a second direction (perpendicular to the first direction). The tensile measurements were performed on an Instron® Tensile Machine 30 (Instron® Corporation, Canton, MA) at 200mm/min. load rate with 2.5cm (one inch) jaw spacing.

Material of the sheath – deployment line construction adjacent to the reinforced portion was smoothed out along the mandrel and a second reference line was drawn around the material 5cm from the first reference line.

35 A second portion of the sheath – deployment line construction was reinforced as follows. A second reference line was drawn around the extruded ePTFE material 5cm from the proximal end of the first reinforced portion. Using the second reference line to align a

2cm wide strip of the above-mentioned ePTFE/FEP composite membrane, the composite membrane was wrapped once around the remaining portion of the extruded ePTFE material to form a second reinforced portion of the sheath – deployment line of the present invention. The second reinforced portion was about 2cm in length. The composite reinforcing
5 membrane material was attached to the extruded ePTFE material as described above, with the exception that the major strength component of the material was parallel to the axis of the mandrel.

Any air trapped in the construction was removed by applying a sacrificial layer of ePTFE tightly around the construction. A one inch (2.54cm) wide film of ePTFE was
10 helically overwrapped around the reinforced portion of the construction. Two layers of the ePTFE film were applied in one direction and two layers were applied in the opposite direction. The construction with sacrificial layers were then placed in an oven heated to 320°C for eight minutes. Upon removal from the heated oven, the combination was allowed to cool to room temperature. The sacrificial ePTFE material was then removed.

The construction was then removed from the mandrel and another mandrel (1.83mm
15 diameter X 30.5cm long) inserted into the reinforced end of the construction. With the mandrel supporting the reinforced end, a 5mm long slit was made proximal to the reinforced portion of the sheath – deployment line construction. A second mandrel was placed inside the construction up to the 5mm slit where it exited the construction. The proximal portion of
20 the sheath – deployment line construction was converted into a filament by placing the proximal end into the chucks of the film wrapper chucks and rotating the film wrapper approximately 2,800 times while the mandrel with the reinforced construction was immobilized. After the construction was spun into a filament, the filament was strengthened by briefly applying heat to the filament with a soldering iron set at 450°C. The strengthened
25 filament was smoothed and rendered more uniform in diameter by passing the filament over a 1.8cm diameter X 3.8cm long dowel heated to approximately 320°C. The filament was passed over the heated dowel at a 45° angle under slight tension. This process was repeated two more times over the entire length of the filament.

The filament portion of the sheath – deployment line of the present invention was
30 routed through a lumen of a primary catheter and connected to a control knob. The control knob was part of a hub located at the proximal end of the primary catheter. When the deployment line portion of the sheath – deployment line was pulled, the sheath portion was retracted from around the stent.

35 Example 2

This example describes the construction of a deployment system of the present invention. Construction of the system begins with the preparation of a distal catheter shaft for receiving an expandable stent. Once the distal catheter was prepared, the expandable stent was placed within a sheath – deployment line. The distal catheter portion of this combination was attached to a primary catheter shaft. The deployment line portion was then routed through the primary catheter to a control knob. The control knob was part of a hub located proximally on the primary catheter. The sheath portion of the sheath – deployment line was in the form of a double-walled tube.

A tubular material three inches long was obtained from Burnham Polymeric, Inc., Glens Falls, NY for use as the distal catheter shaft. The tube was made of a polyether block amide material, commonly known as PEBAX® resin and reinforced with a stainless steel braid. The outer diameter (OD) was 1.01 mm and the inner diameter (ID) was 0.76 mm. An endo-prosthesis mounting member in the form of a compressible material was then placed on the catheter. To place the endo-prosthesis mounting member on the catheter, the catheter was mounted on a mandrel having an outer diameter of 0.74 mm. A film of porous expanded polytetrafluoroethylene (ePTFE) was obtained according to the teachings in U.S. Patent No. 5,814,405, issued to Branca, which is incorporated herein by reference. A discontinuous coating of fluorinated ethylene propylene (FEP) was applied to one side of the ePTFE material in accordance with U.S. Patent No. 6,159,565, issued to Campbell et al., which is incorporated herein by reference. An edge of the ePTFE – FEP composite film two inches wide was attached with heat to the catheter shaft. After initial attachment, the film was wrapped around the catheter shaft forty-five (45) times under light tension. With every fifth wrap of the film, and on the final layer, the film is further attached to itself with heat. This procedure provides an endo-prosthesis mounting member on the distal catheter shaft. The expandable stent is mounted over the endo-prosthesis mounting member. The endo-prosthesis mounting member provides a means of retaining an expandable stent on the catheter shaft during storage, delivery to an implantation site, and deployment of the expandable stent at the implantation site. Optionally, the endo-prosthesis mounting member may be reinforced with a thin coating of an elastomeric material such as silicone, urethane, and/or a fluoroelastomer.

An eight (8) cell, 6mm diameter, nitinol stent was obtained from Medinol Ltd., Tel-Aviv, Israel. The stent was placed over the endo-prosthesis mounting member of the catheter in an expanded state. The combination was placed within a machine having a mechanical iris that compacts or compresses the stent portion of the assembly onto the endo-prosthesis mounting member. While retained in the mechanical iris machine, the stent was reduced in temperature from room temperature to approximately five degrees centigrade (5°C). At the reduced temperature, the iris machine was actuated to compact, or

collapse, the stent onto the endo-prosthesis mounting member. While in the refrigerated, compressed configuration, the catheter, endo-prosthesis mounting member, and stent were placed within a sheath – deployment line of the present invention.

The sheath – deployment line having a length equal to, or greater than, the length of
5 the final deployment system was made as follows. A stainless steel mandrel measuring 1.73 mm in diameter was covered with a sacrificial layer of ePTFE. The sacrificial ePTFE material aids in removal of the sheath – deployment line from the mandrel. Two wraps of a thin, polytetrafluoroethylene (PTFE) membrane were applied to the mandrel. The ePTFE membrane was applied so the primary strength of the film was oriented parallel with the
10 longitudinal axis of the mandrel. The film was initially tacked in place with heat applied with a soldering iron. The membrane thickness measured about 0.0002" (0.005 mm) and had tensile strengths of about 49,000 psi (about 340 KPa) in a first direction and of about 17,000 psi (about 120 KPa) in a second direction (perpendicular to the first direction). The tensile measurements were performed at 200mm/min. load rate with a 1" (2.5 cm) jaw spacing. The
15 membrane had a density of about 2.14g/cm³. The membrane was further modified by the application of an FEP coating on one side in accordance with U.S. Patent No. 6,159,565, issued to Campbell et al., which is incorporated herein by reference. Next, two wraps of another ePTFE film made according to the teachings of Bacino in U.S. Patent No. 5,476,589 and further modified with a discontinuous layer of an FEP material applied to one side of the
20 ePTFE film were applied to one end of the construction (approx. 1" wide). U.S. Patent No. 5,476,589. These two wraps had the primary strength direction of the film oriented perpendicular to the mandrel's longitudinal axis. These layers of film provide additional "hoop" or "radial" strength to the sheath – deployment line construct. The mandrel and sheath – deployment line construct were placed in an air
25 convection oven obtained from The Grieve Corporation, Round Lake, IL, and subjected to a thermal treatment of 320°C for 12 minutes. After air cooling, the ePTFE/FEP tube construct was removed from the mandrel and the sacrificial ePTFE layer removed. In this example, a length of sheath – deployment line extending beyond the end of the stent was provided. The additional length of sheath – deployment line was folded back over sheath portion enclosing
30 the stent to form a double-walled construct. The double-walled sheath – deployment line had an inner wall and an outer wall. The inner wall was against the stent and the outer wall included the integral deployment line portion of the construct. The construct was then attached to a primary catheter shaft using heat and standard materials.

The deployment line portion of the sheath – deployment line was made by splitting
35 the sheath – deployment line along its length from a proximal end up to, but not including, the sheath portion enclosing the stent. The material thus obtained was gathered into a filament by rolling the material. Heat was applied to the material to set the material in the

filamentous form. The deployment line filament was routed through a lumen in the primary catheter and connected to a control knob. The control knob was part of a hub located at the proximal end of the primary catheter. When the deployment line portion of the sheath – deployment line was pulled, the sheath portion was retracted from around the stent.

5

Example 3

This example describes the incorporation of a means for initiating or maintaining conversion of the sheath portion of the sheath – deployment line to deployment line by
10 introducing perforations and intentional stress risers into the sheath.

The sheath – deployment line from Example 2 is modified as follows. Prior to rolling the sheath portion into a double-walled construct and loading the stent therein, the sheath is perforated and/or supplied with “stress risers” that facilitate in separation of the tubular sheath upon retraction of the deployment line portion. An appropriate laser for making the
15 perforations or stress risers is a 20 watt CO₂ laser obtained from Universal Laser Systems, Scottsdale, AZ. To form the perforations in the sheath portion, the sheath is placed on a sandblasted stainless steel mandrel and exposed to the laser to cut a series of holes in a part of the tube that will subsequently serve as the outer wall of the double-walled construct. The geometry of the holes can be varied depending on the application. The perforated
20 sheath portion is used on a deployment line system of the present invention as described in Example 2. In this example, tension applied to the deployment line portion at the hub end of the catheter results in retraction of the sheath from around the stent and also results in parting the sheath at the perforations. As the sheath portion is separated, the sheath material becomes convertible to deployment line.

25

Example 4

This example describes the incorporation of a means for initiating or maintaining conversion of the sheath portion of the sheath – deployment line to deployment line by the
30 use of an appropriate splitting means.

The primary catheter from Example 2 is modified as follows. The primary portion of the catheter is provided with a notch in the wall in 180 degrees opposition and slightly distal to the entry point of the deployment line portion into the catheter lumen. The notch is further modified to provide a small cutting edge in the notch. In one embodiment, the cutting edge
35 is simply attached to the notch with heat, adhesives, and the like. In another embodiment, the cutting edge is formed by exposing a portion of a metallic braid used to reinforce the catheter shaft and forming the braid into a cutting edge. In this example, tension applied to

the deployment line portion at the hub end of the catheter results in retraction of the sheath from around the stent and also results in parting the sheath at the perforations. As the sheath portion is separated, the sheath material becomes convertible to deployment line.

5 Example 5

This example describes the construction of a deployment system of the present invention for use in the delivery and deployment of both self-expanding as well as balloon expandable devices. The deployment system of this example utilizes an endo-prosthesis
10 mounting member in the form of an inflatable balloon.

A sheath – deployment line having a length equal to, or greater than, the length of the final deployment system is made as follows. A stainless steel mandrel measuring 1.73 mm in diameter is covered with a sacrificial tube of ePTFE. The sacrificial ePTFE material aids in removal of the sheath – deployment line from the mandrel. Two wraps of a thin,
15 polytetrafluoroethylene (PTFE) membrane is applied to the mandrel. The ePTFE membrane is applied so the primary strength of the film is oriented parallel with the longitudinal axis of the mandrel. The film is initially tacked in place with heat applied with a soldering iron. The membrane thickness measured about 0.0002" (0.005 mm) and had tensile strengths of about 49,000 psi (about 340 KPa) in a first direction and about 17,000 psi (about 120 KPa) in
20 a second direction (perpendicular to the first direction). The tensile measurements are performed at 200mm/min. load rate with a 1 inch (2.5 cm) jaw spacing. The membrane has a density of about 2.14g/cm³. The membrane is further modified by the application of a fluorinated ethylene propylene (FEP) coating on one side in accordance with U.S. Patent No. 6,159,565, issued to Campbell et al. and incorporated herein by reference. Next, two wraps
25 of another ePTFE film made according to the teachings of Bacino in U.S. Patent No. 5,476,589, which is incorporated herein by reference, and further modified with a discontinuous layer of an FEP material applied to one side of the ePTFE film are applied to one end of the construction (approx. 1" wide). These two wraps have the primary strength direction of the film oriented perpendicular to the mandrel's longitudinal axis. These layers
30 of film provide additional "hoop" or "radial" strength to the sheath – deployment line construct. The mandrel and sheath – deployment line construct are placed in an air convection oven obtained from The Grieve Corporation, Round Lake, IL, and subjected to a thermal treatment of 320°C for 12 minutes. After air cooling, the ePTFE/FEP tube construct is removed from the mandrel and the sacrificial ePTFE layer removed. Placement of this
35 construct over an expandable stent and formation of a deployment line portion therefrom is described below.

As seen in Figure 10, a balloon expandable NIRflex™ stent (14), available from Medinol Ltd, Tel-Aviv, Israel, is placed over and compacted around a deflated and collapsed angioplasty balloon mounted on a delivery catheter shaft (19). The angioplasty balloon is made in accordance with U.S. 5,752,934 to Campbell et al. available
5 from W. L. Gore & Associates, Inc., Flagstaff, AZ under the tradename APTERA® angioplasty balloon. The APTERA® angioplasty balloon serves as an endo-prosthesis mounting member (18a) for receiving and retaining the compacted stent (14).

10 While the stent is confined in a compacted configuration, a length of sheath – deployment line (12) is placed over the compacted stent and extended beyond the end of the stent. The additional length of sheath – deployment line is folded back over sheath portion enclosing the stent to form a double-walled construction. The double-walled sheath – deployment line has an inner wall and an outer wall. The inner wall is against the stent and the outer wall includes the integral deployment line portion of the construct.

15 The deployment line portion of the sheath – deployment line is made by splitting the sheath – deployment line along its length from the proximal end toward the distal end for a distance. The slit can range in length from about one centimeter to substantially the entire length of the sheath – deployment line construction up to, but not including, the sheath portion enclosing the stent. It is preferred to form the deployment line portion near the
20 proximal end of the delivery catheter. The material thus obtained is gathered into a filament by rolling the material. Heat is applied to the material to set the material in the filamentous form. The sheath – deployment line is routed through a dedicated lumen in the delivery catheter and exits at a hub where the deployment line portion is attached to a control knob. The control knob is part of a hub located at the proximal end of the primary catheter. When
25 tension is applied to the deployment line portion of the sheath – deployment line, the sheath portion retracts from around the stent. Removal of the sheath portion from the underlying stent frees the stent to expand. The NIRflex™ stent of this example is expanded by inflating the APTERA® angioplasty balloon. Once the stent is expanded, the balloon is deflated and the delivery catheter along with the sheath – deployment line construction removed from the
30 implant recipient. When self-expanding stents are used in the present invention, the balloon is useful as an endo-prosthesis mounting member.

CLAIMS

1. A deployment system for an endoluminal device comprising:
 - an expandable endoluminal device mounted on a delivery catheter provided with an endo-prosthesis mounting member;
 - a retractable sheath in the form of a continuous thin-walled tube adapted to cover and constrain at least a portion of the endoluminal device in an introductory profile;
 - wherein the deployment system includes a deployment line integral with the retractable sheath to effectuate endoluminal device deployment;
 - wherein upon endoluminal device deployment, the sheath retracts from the endoluminal device through actuation of the deployment line and splits to transform from the sheath to an elongated filament; and
 - wherein the elongated filament is removed from the deployment system along with the deployment line.
2. The deployment system of claim 1 wherein the sheath comprises an extruded thin walled tube.
3. The deployment system of claim 1 wherein the sheath comprises a thin continuous film.
4. The deployment system of claim 1 wherein the sheath is in the form of an extruded thin-walled tube reinforced with a thin continuous film tube.
5. The deployment system of claim 1 wherein the sheath confines an endoprosthesis mounting member to a smaller profile on the delivery catheter than an endoprosthesis mounting member without the sheath.
6. The deployment system of claim 1 wherein means are provided to aid in splitting from a sheath to the filament.
7. The deployment system of claim 6 wherein the means to aid in splitting comprises a splitter.

8. The deployment system of claim 6 wherein the means to aid in splitting comprises an engineered defect incorporated into the sheath - deployment line.
9. The deployment system of claim 1 wherein the sheath comprises a wall with a thickness of less than 0.05 mm.
10. The deployment system of claim 1 wherein the sheath comprises a fluoropolymer that surrounds the endoluminal device in a double layer.
11. The deployment system of claim 10 wherein one layer of the double layer is placed over the other layer and one layer moves past the other layer upon deployment.
12. The deployment system of claim 1 wherein the system includes a single catheter shaft.
13. The deployment system of claim 1 wherein actuation of the deployment line is achieved at least in part with an active elastic element incorporated therein.
14. The deployment system of claim 12 wherein the catheter shaft extends distally beyond the endoluminal device in its introductory profile.
15. The deployment system of claim 1 further comprising at least a portion of a second catheter co-axially placed over at least a portion of said delivery catheter.
16. The deployment system of claim 14 wherein said at least a portion of a second catheter substantially confines said sheath - deployment line.
17. The deployment system of claim 1 wherein the endo-prosthesis mounting member is in the form of an inflatable balloon.
18. The deployment system of claim 1 wherein the endoprosthesis mounting member is non-inflatable.

19. The deployment system of claim 17 wherein the inflatable balloon includes polytetrafluoroethylene.

20. The deployment system of claim 1 wherein the length of sheath retracted from the self-expanding endoluminal device is substantially equal to the length of deployment line displaced during deployment of the self-expanding endoluminal device.

21. The deployment system of claim 1 wherein the length of sheath retracted from the self-expanding endoluminal device is essentially half the length of deployment line displaced during deployment of the self-expanding endoluminal device.

22. The deployment system of claim 1 wherein the sheath is not attached to a catheter shaft.

23. A deployment system for an endoluminal device comprising:
an expandable endoluminal device placed over an endo-prosthesis mounting member and at least partially enclosed by a retractable sheath;
wherein said retractable sheath comprises a polymeric material in the form of a continuous thin-walled tube having at least one thin wall adapted to surround at least a portion of the expandable endoluminal device and constrain the expandable endoluminal device in an introductory profile on the endo-prosthesis mounting member;
an extension of the retractable sheath in the form of a filamentous deployment line, wherein the deployment line extension is integral and continuous with the retractable sheath; and
wherein upon actuation of the deployment line, the retractable sheath separates from the endoluminal device and converts from the retractable sheath to form a single elongated deployment line filament.

24. The deployment system of claim 23 wherein the sheath is in the form of an extruded thin-walled tube.

25. The deployment system of claim 23 wherein the sheath is in the form of a thin continuous film.
26. The deployment system of claim 23 wherein the sheath is in the form of an extruded thin-walled tube reinforced with a thin continuous film tube.
27. The deployment system of claim 23 wherein the sheath confines an endoprosthesis mounting member to a smaller profile on the delivery catheter than an endoprosthesis mounting member without the sheath.
28. The deployment system of claim 23 wherein the removable sheath is split to convert the sheath to the deployment line.
29. The deployment system of claim 23 wherein the sheath comprises a continuous film that surrounds the endoluminal device in a double layer.
30. The deployment system of claim 23 wherein the sheath comprises an extruded fluoropolymer tube that surrounds the endoluminal device in a double layer.
31. The deployment system of claim 29 wherein the sheath is convertible to deployment line over at least a portion of the sheath length.
32. The deployment system of claim 23 further comprising a catheter placed within the endo-prosthesis mounting member.
33. The deployment system of claim 23 wherein the endo-prosthesis mounting member is in the form of an inflatable balloon.
34. The deployment system of claim 33 wherein the inflatable balloon includes polytetrafluoroethylene.
35. The deployment system of claim 23 wherein the endo-prosthesis mounting member is non-inflatable.
36. The deployment system of claim 32 wherein the catheter has a single lumen.

37. The deployment system of claim 23 further comprising at least a portion of a second catheter co-axially placed over at least a portion of said delivery catheter.
38. The deployment system of claim 37 wherein said at least a portion of a second catheter substantially confines said sheath - deployment line.
39. The deployment system of claim 32 further comprising means on the catheter for initiating conversion of the removable sheath to the deployment line.
40. The deployment system of claim 23 wherein the removable sheath is split by the means to initiate conversion of the removable sheath to the deployment line.
41. The deployment system of claim 23 wherein the polymeric material includes a fluoropolymer.
42. The deployment system of claim 41 wherein the fluoropolymer is polytetrafluoroethylene.
43. The deployment system of claim 42 wherein the polytetrafluoroethylene is porous expanded polytetrafluoroethylene.
44. The deployment system of claim 43 wherein the porous expanded polytetrafluoroethylene is in the form of a tube.
45. The deployment system of claim 44 wherein the tube has a wall with a thickness of less than 0.05 mm.
46. The deployment system of claim 23 wherein a first portion of the removable sheath substantially surrounds at least a portion of the self-expanding endoluminal device and a second portion of the removable sheath substantially covers the first portion.
47. The deployment system of claim 46 wherein the deployment line is integral with the second portion of the removable sheath.

48. The deployment system of claim 23 wherein the sheath is not attached to a catheter shaft.

1/13

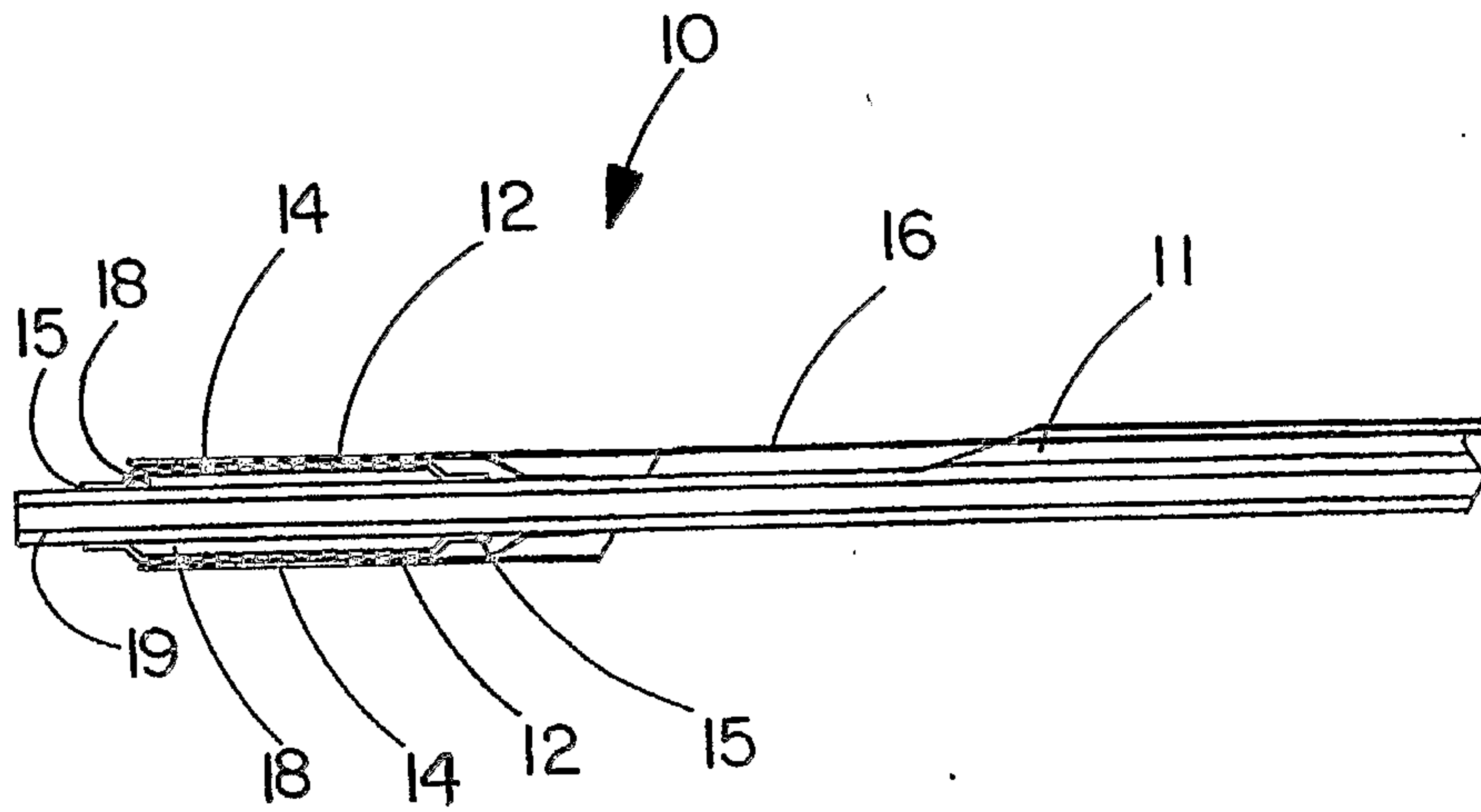

FIG. 1

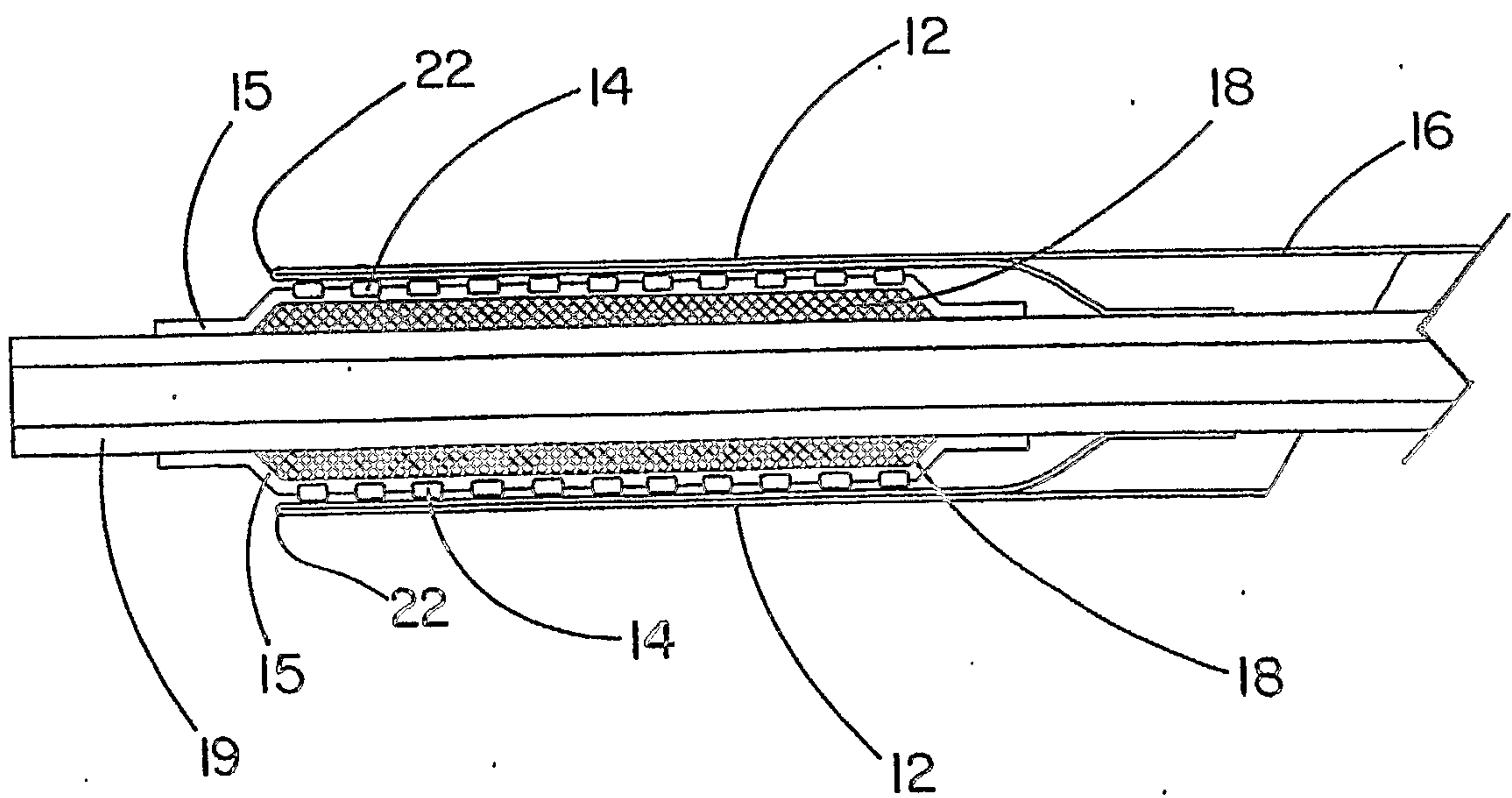

FIG. 1A

2/13

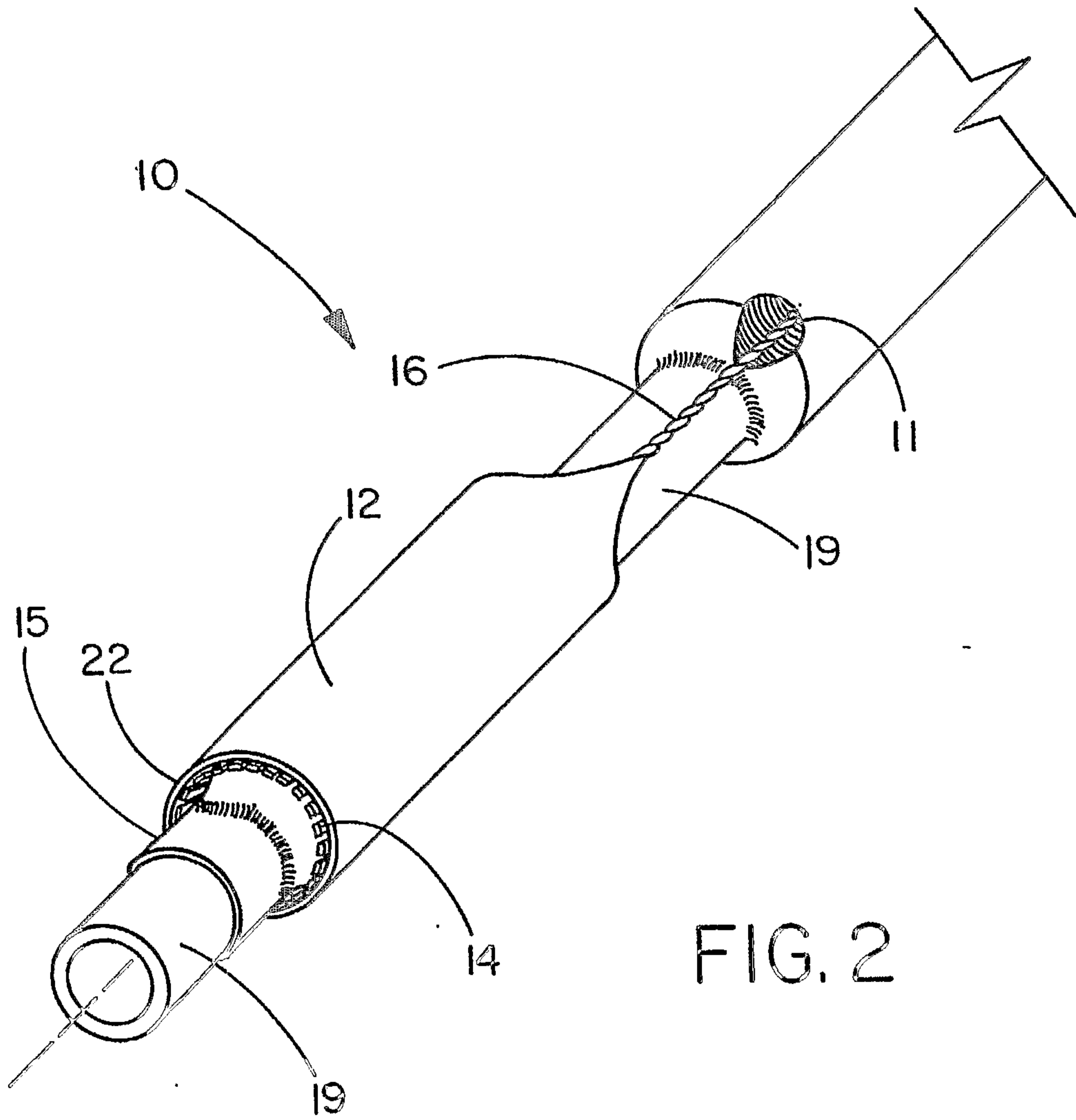

FIG. 2

3/13

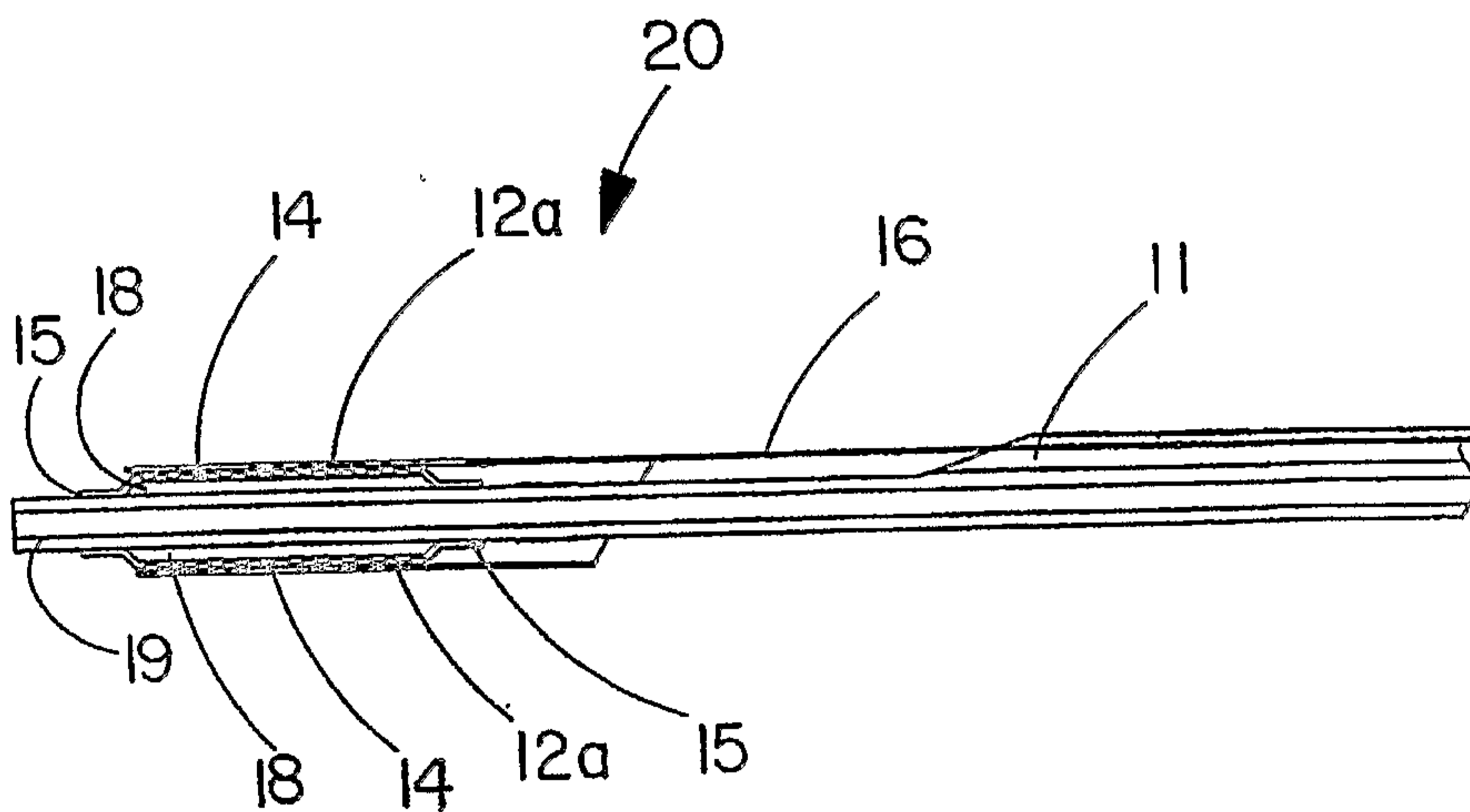

FIG. 3

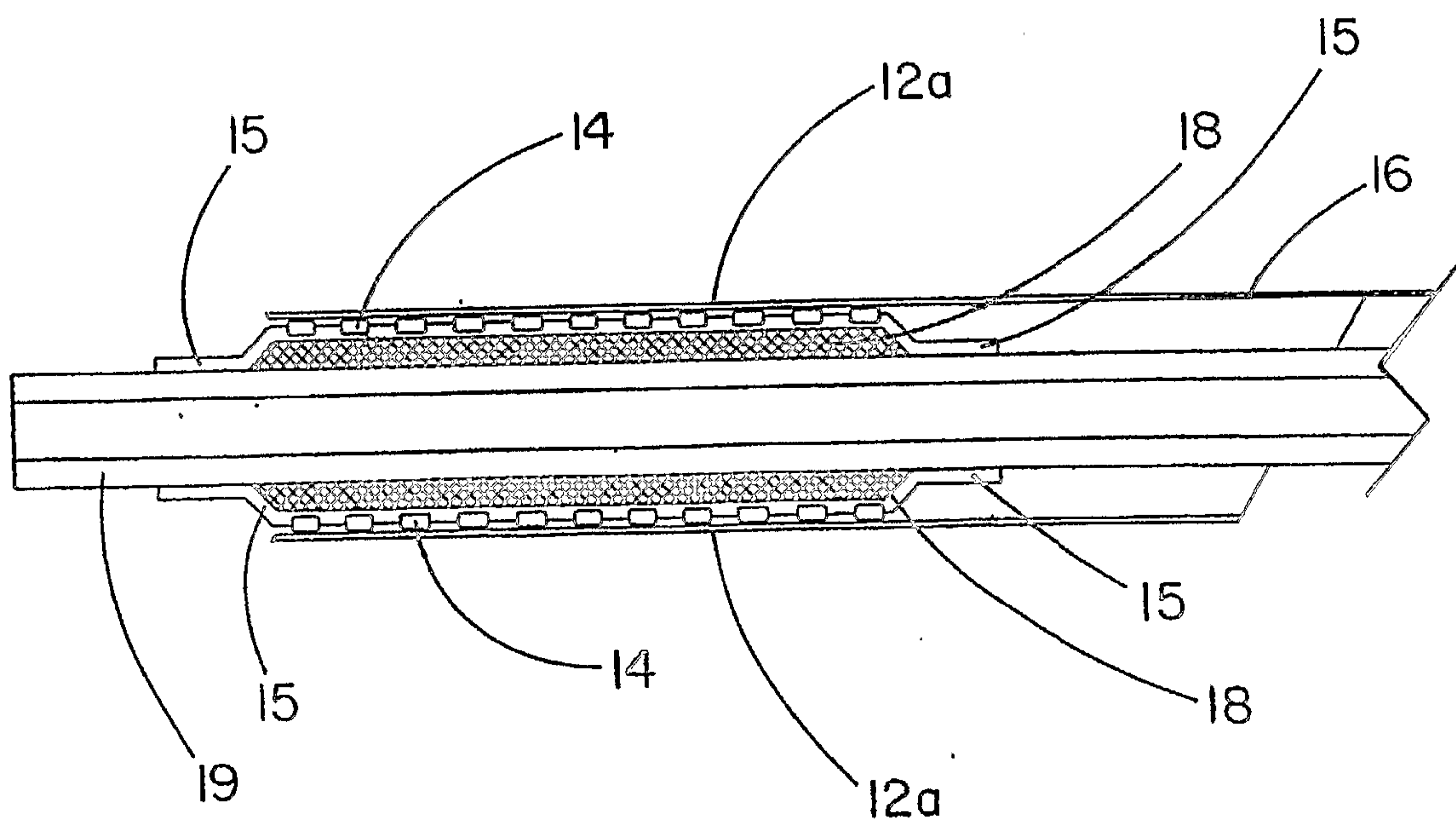

FIG. 3A

4/13

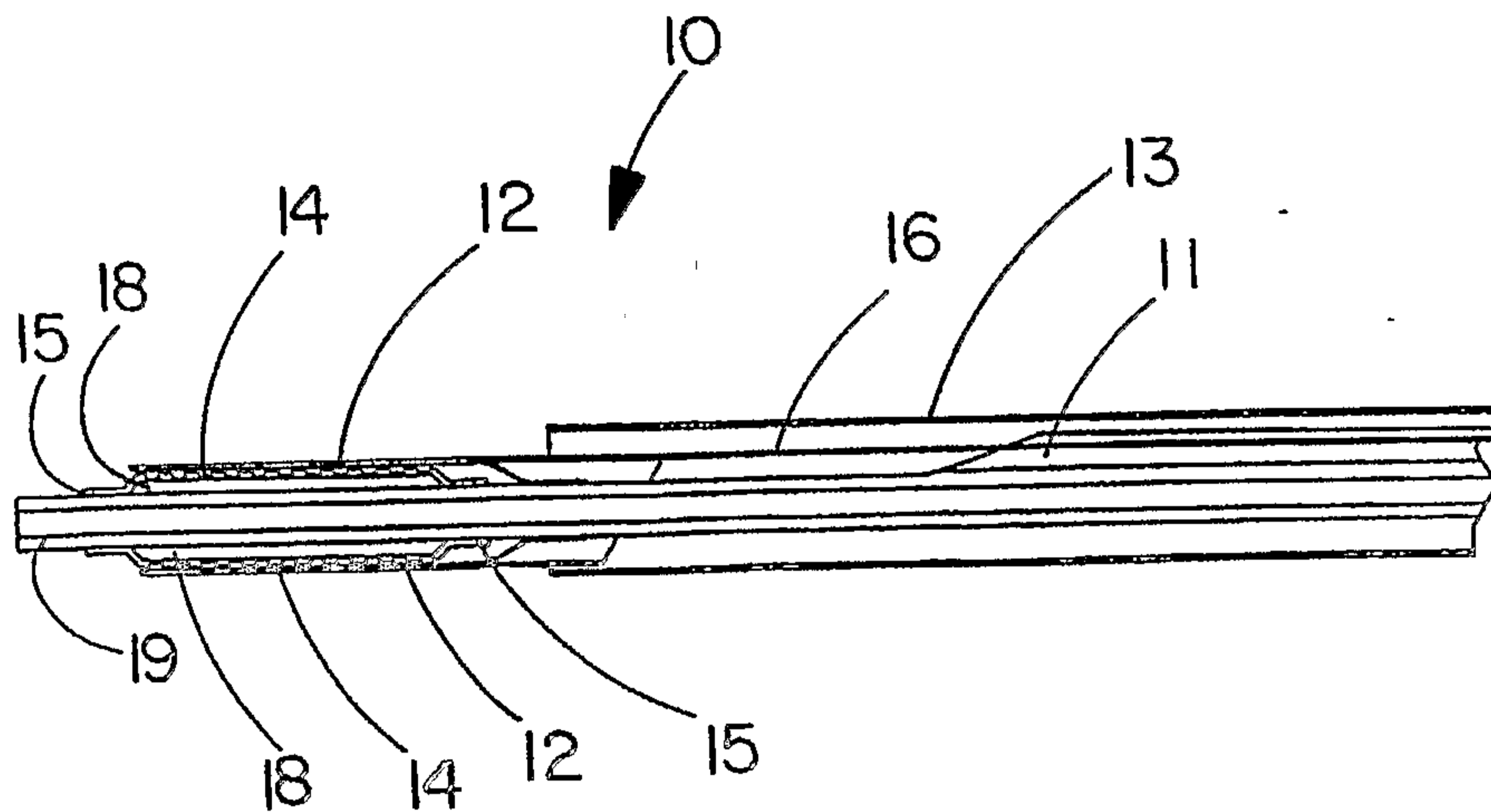

FIG. 4

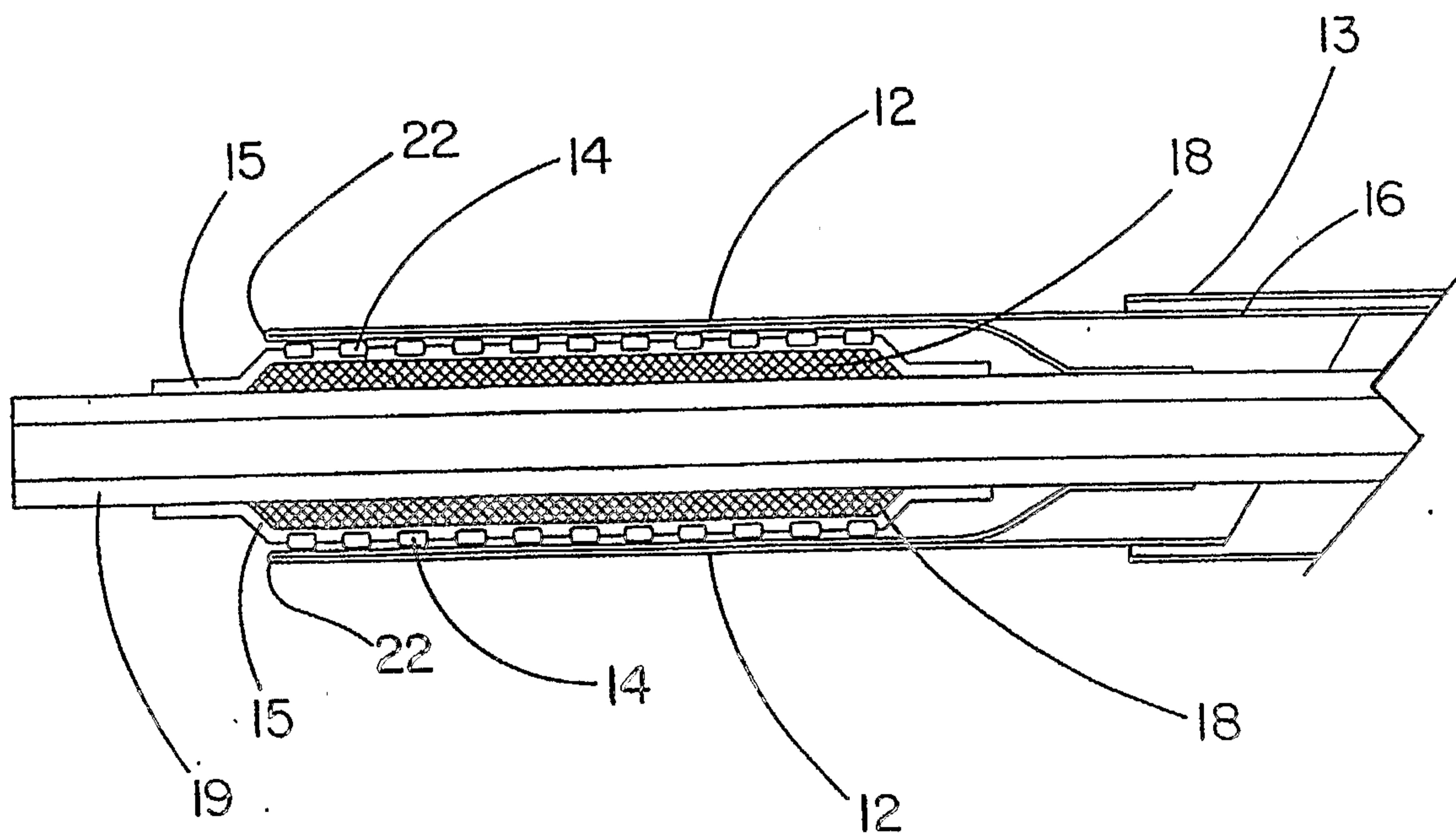

FIG. 4A

5/13

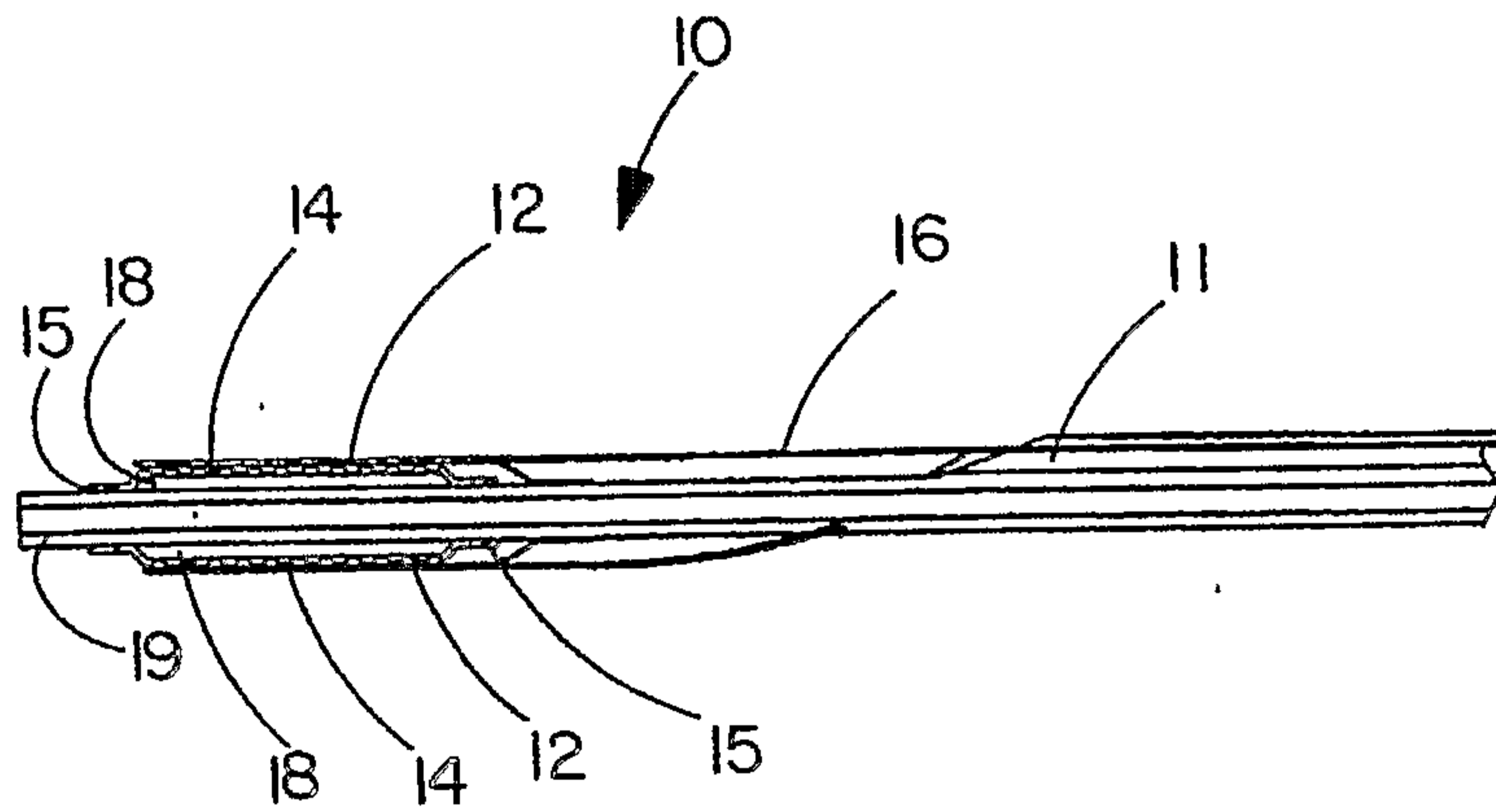

FIG. 5

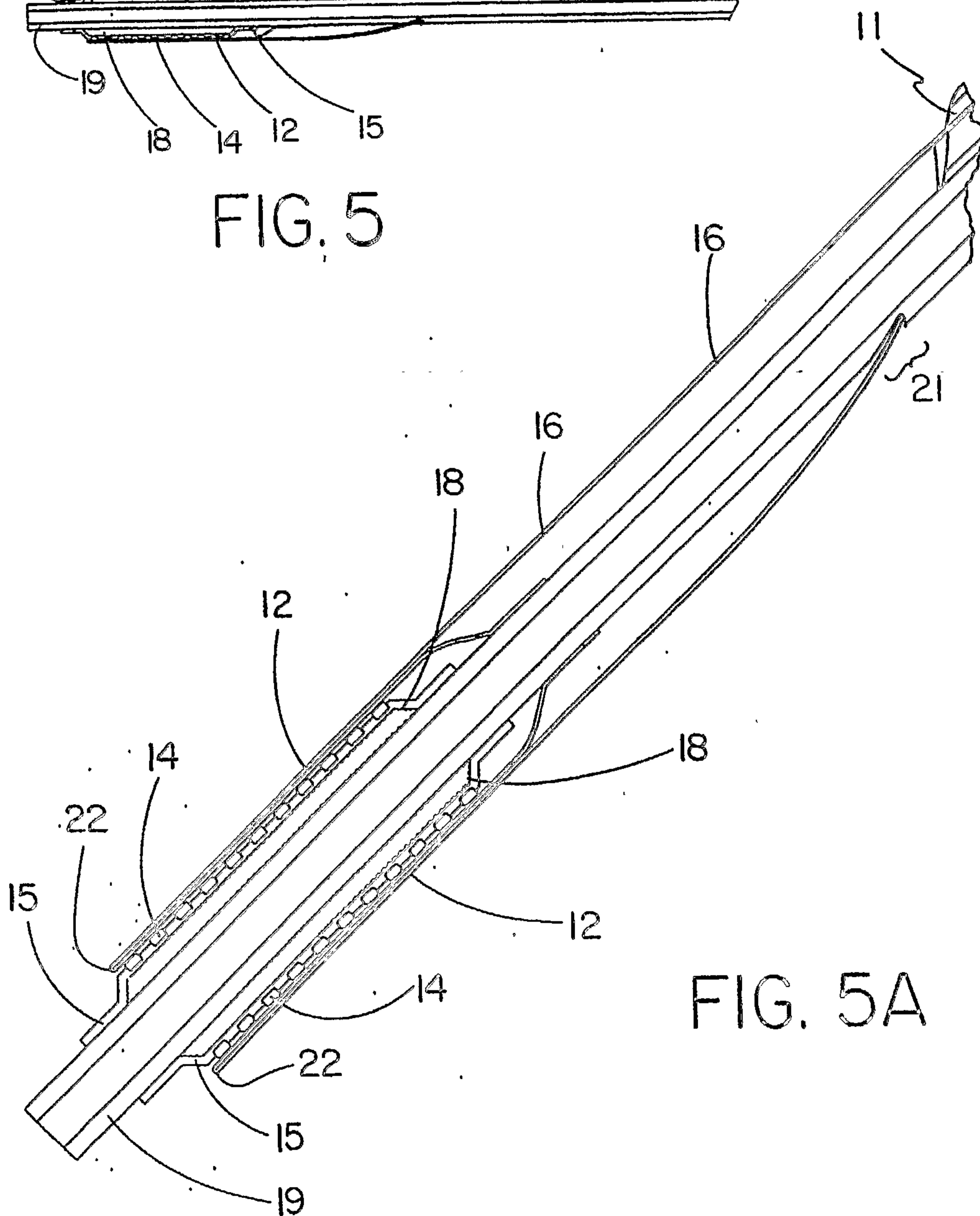

FIG. 5A

6/13

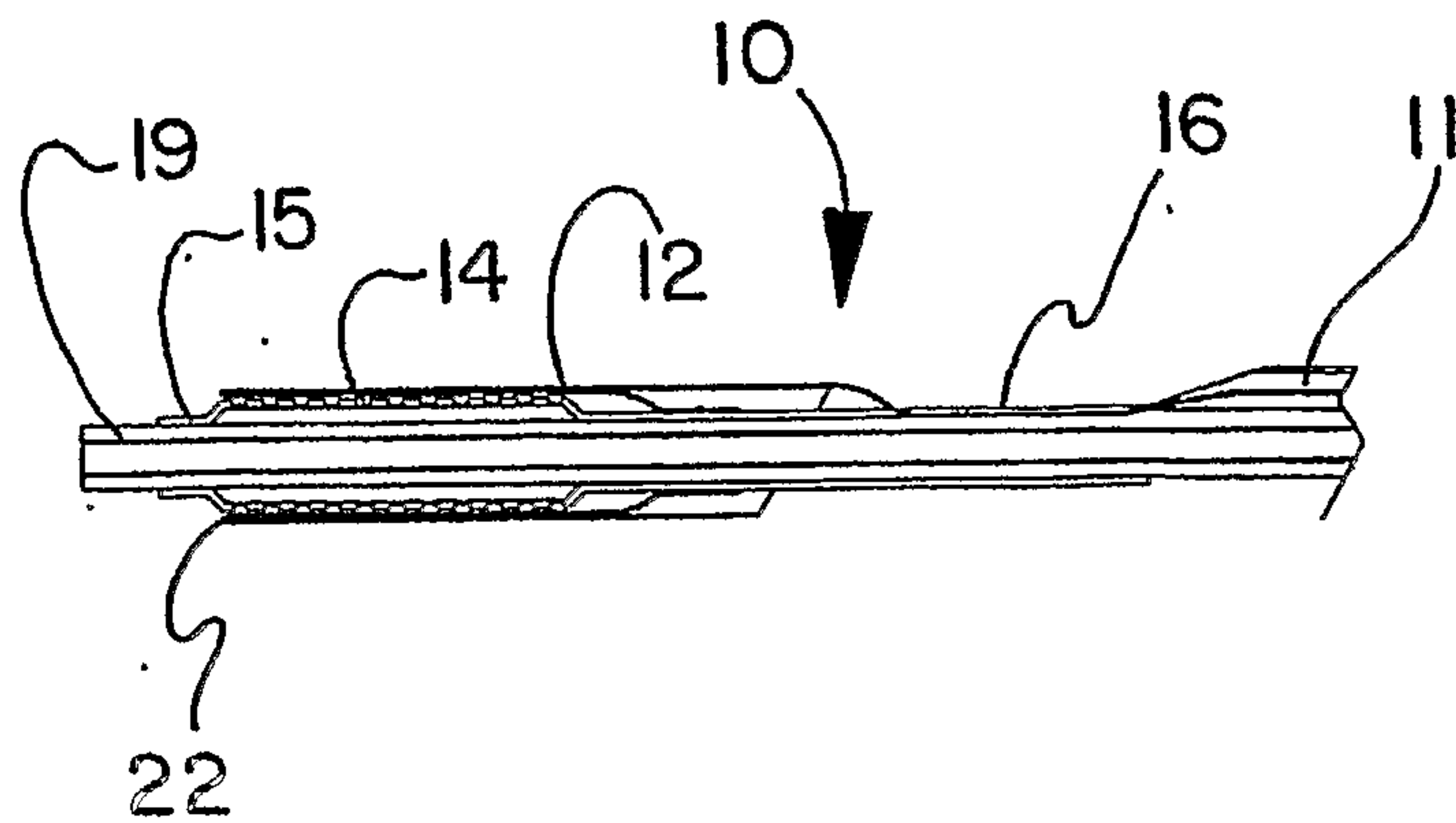

FIG. 6

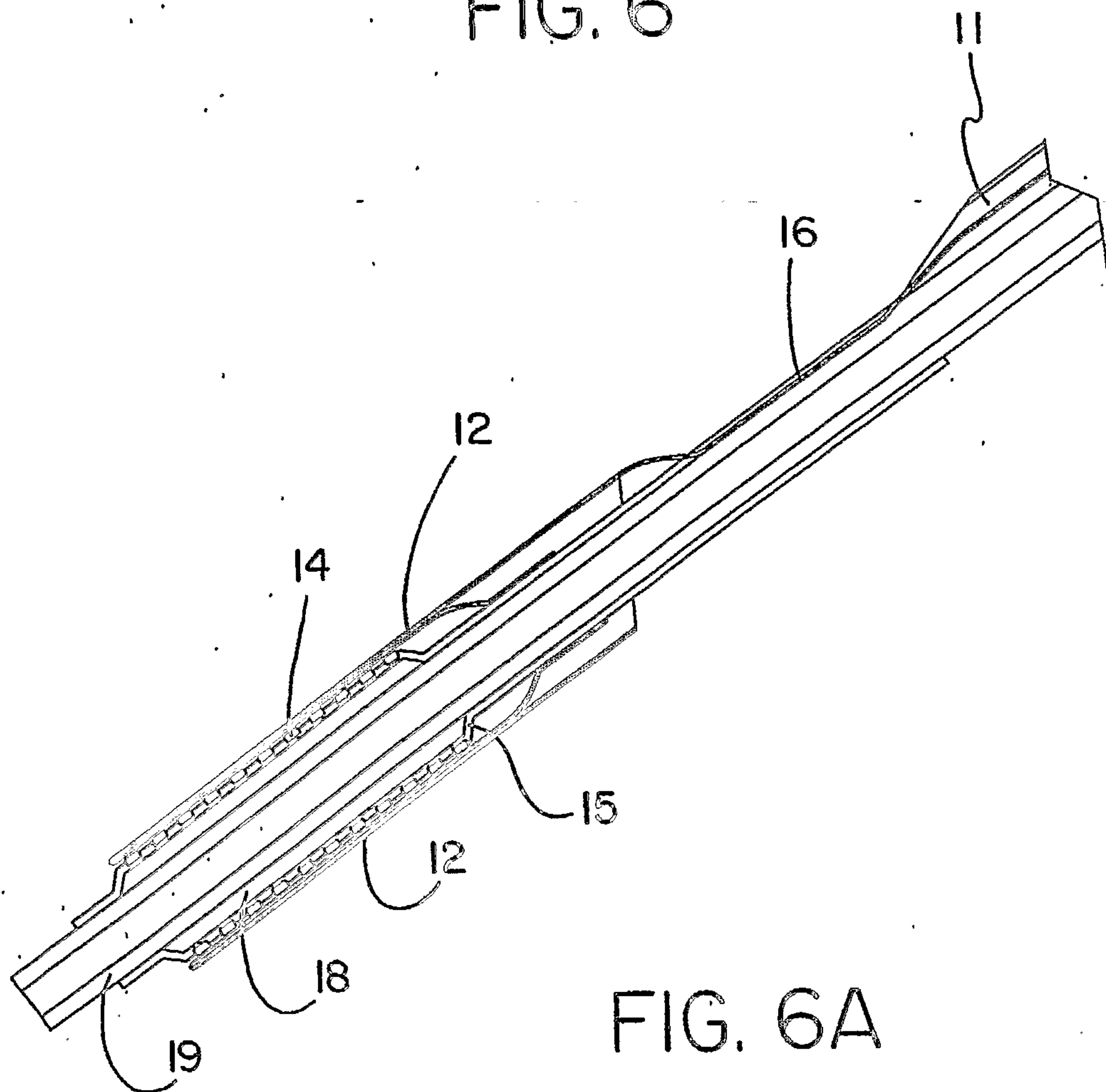

FIG. 6A

7/13

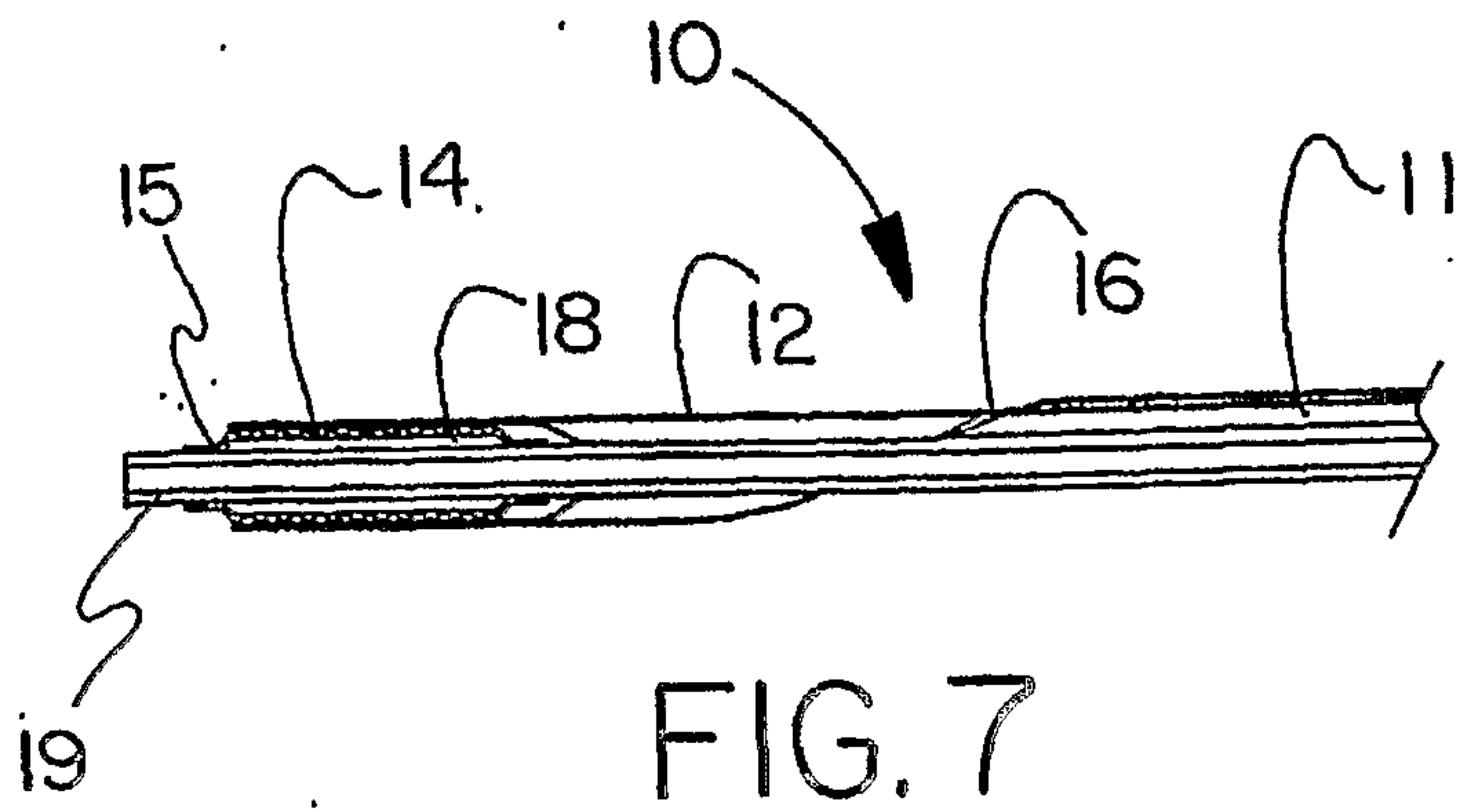

FIG. 7

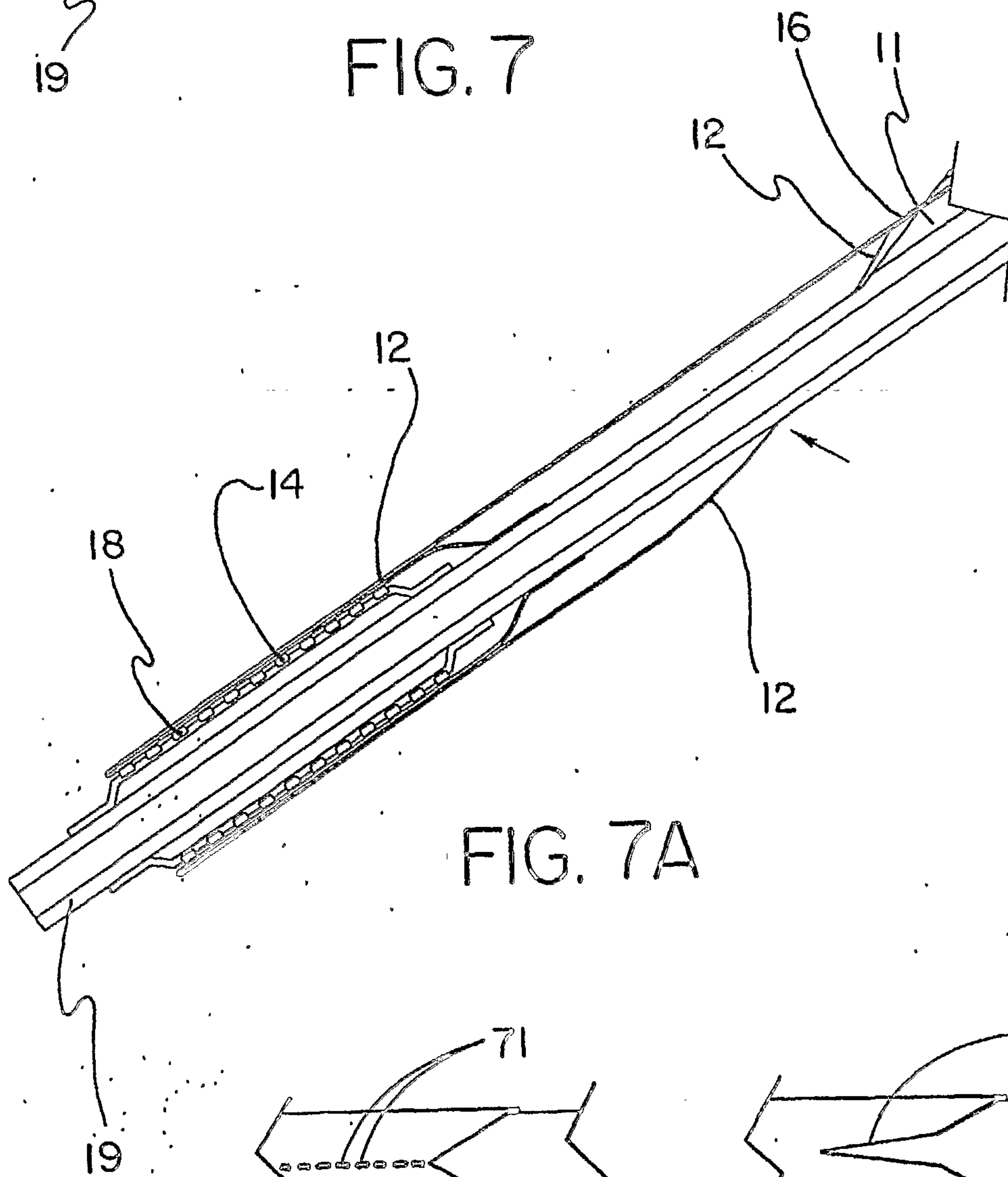

FIG. 7A

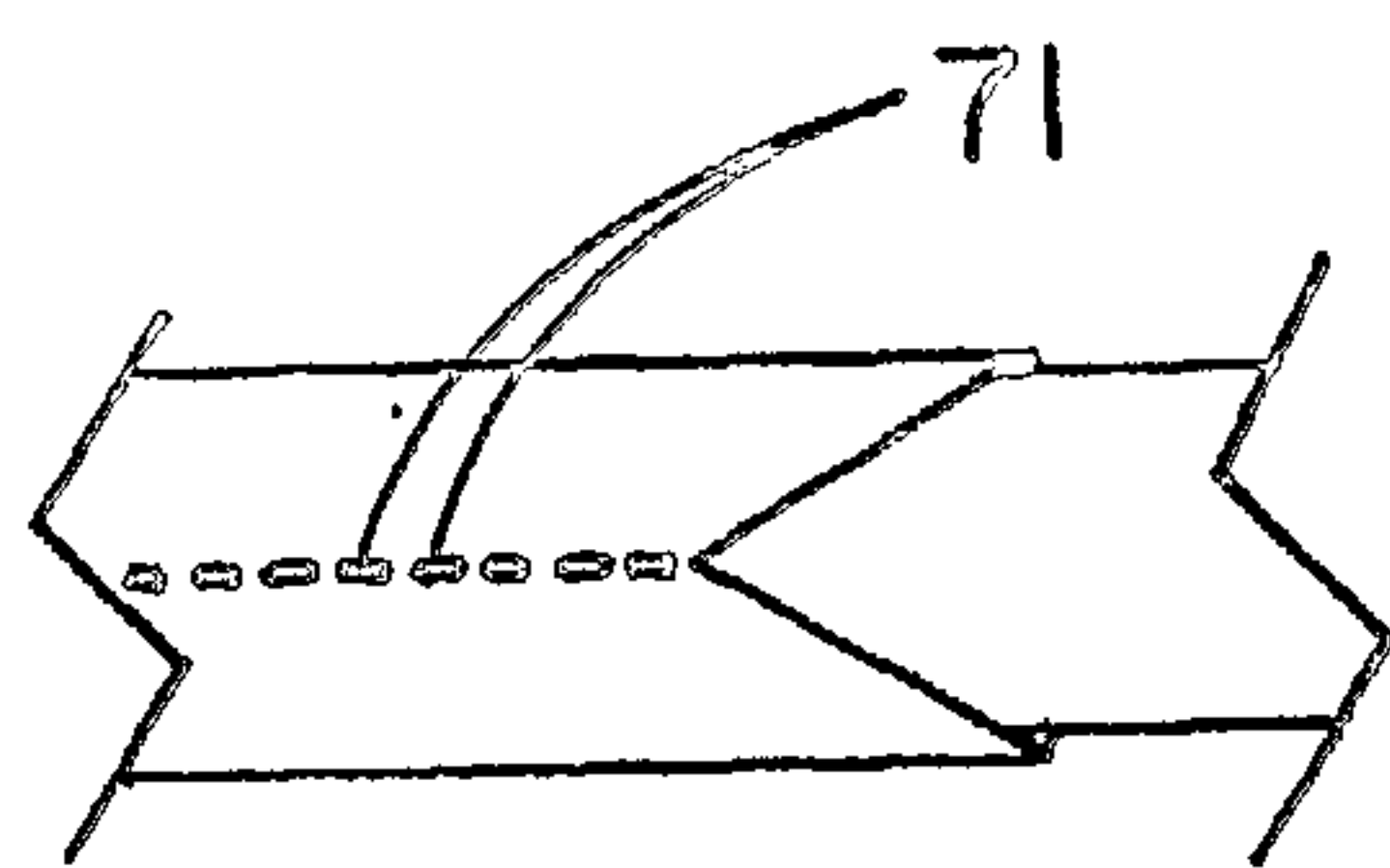

FIG. 7B

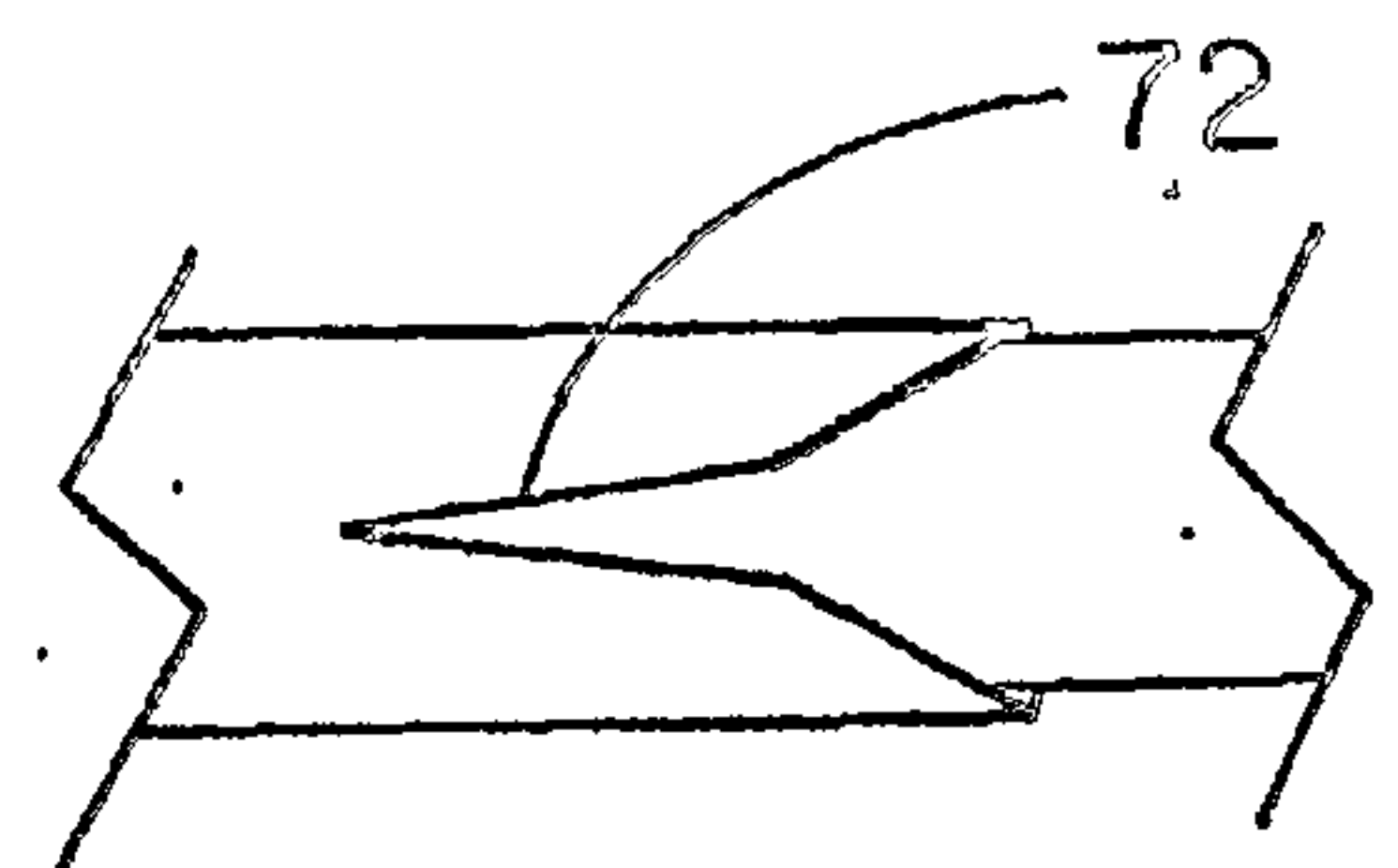

FIG. 7C

8/13

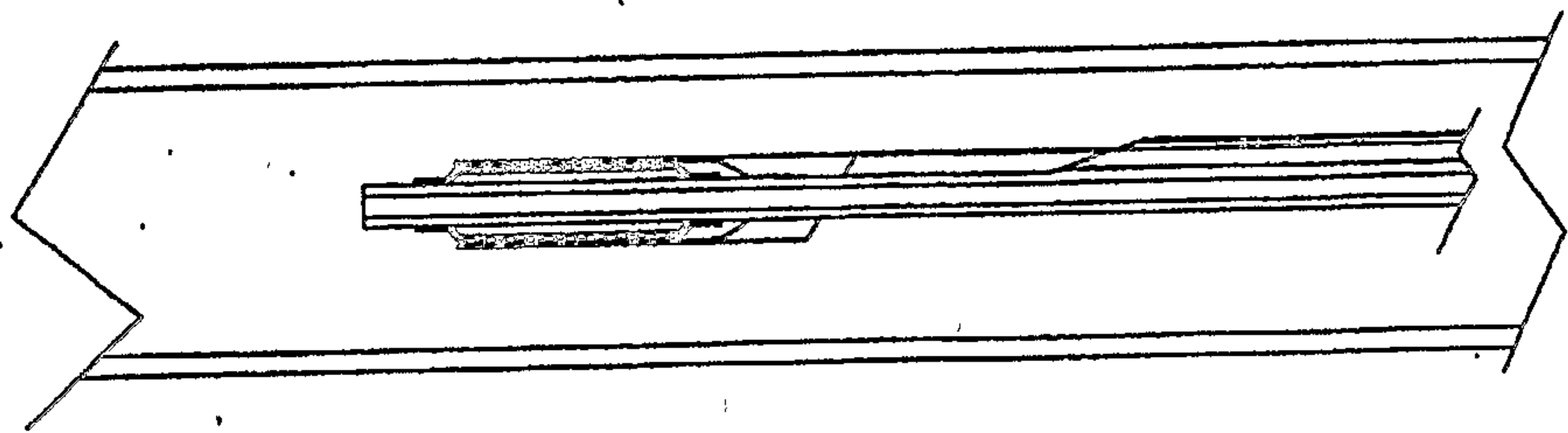

FIG. 8

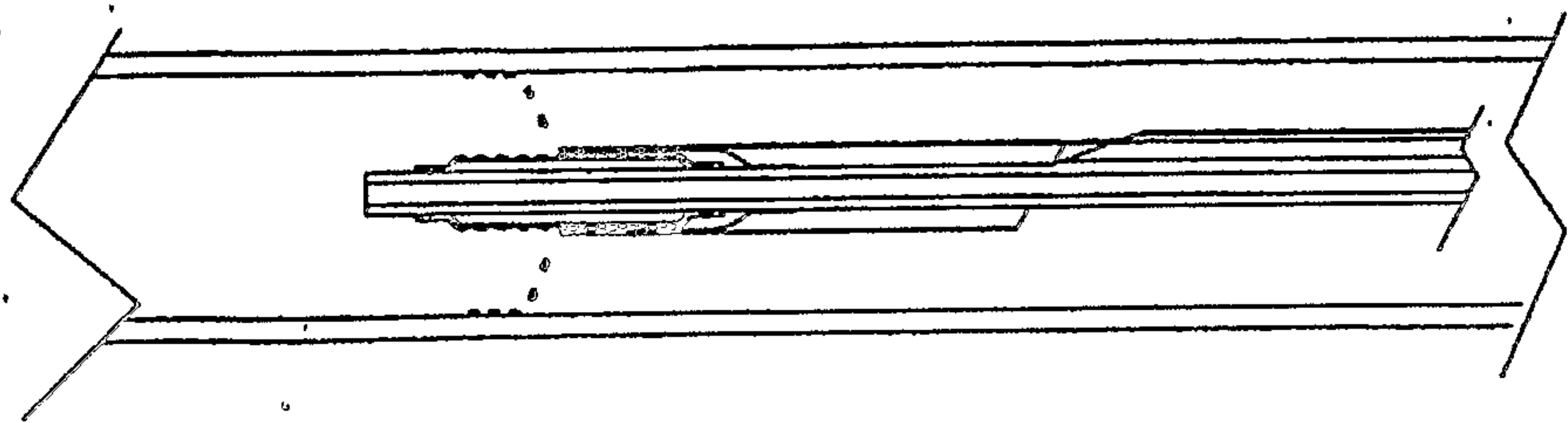

FIG. 8A

9/13

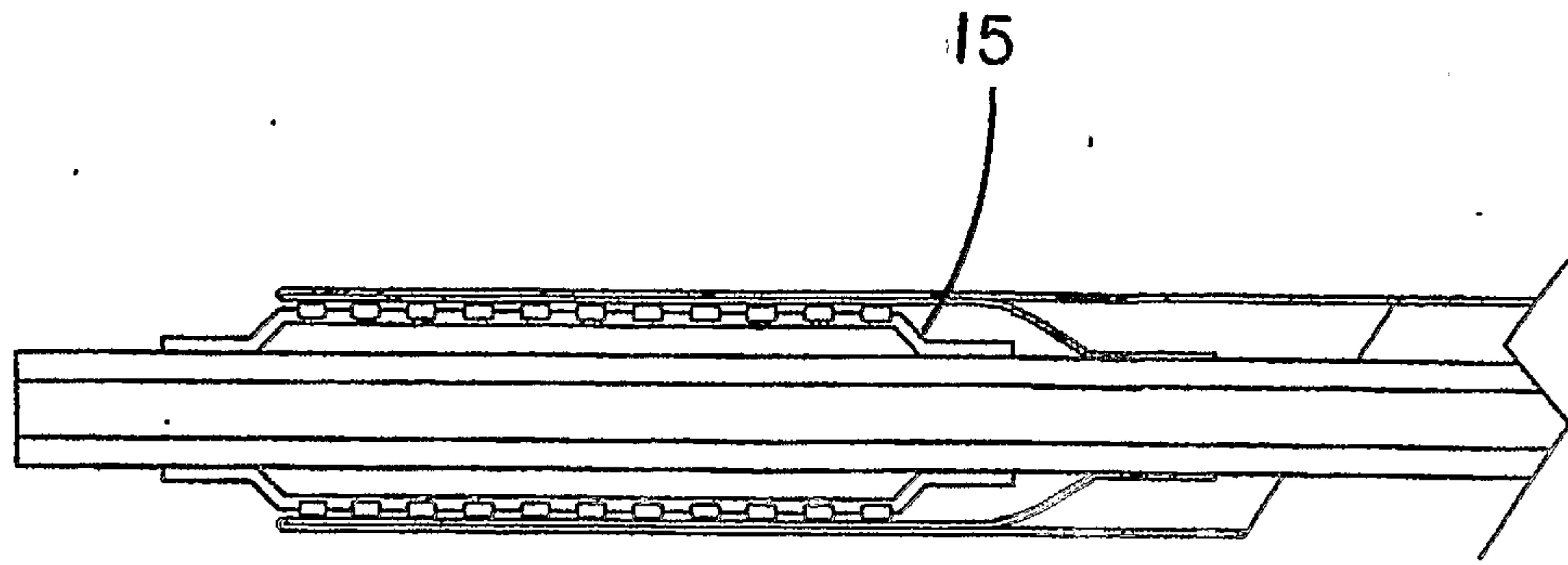

FIG. 9

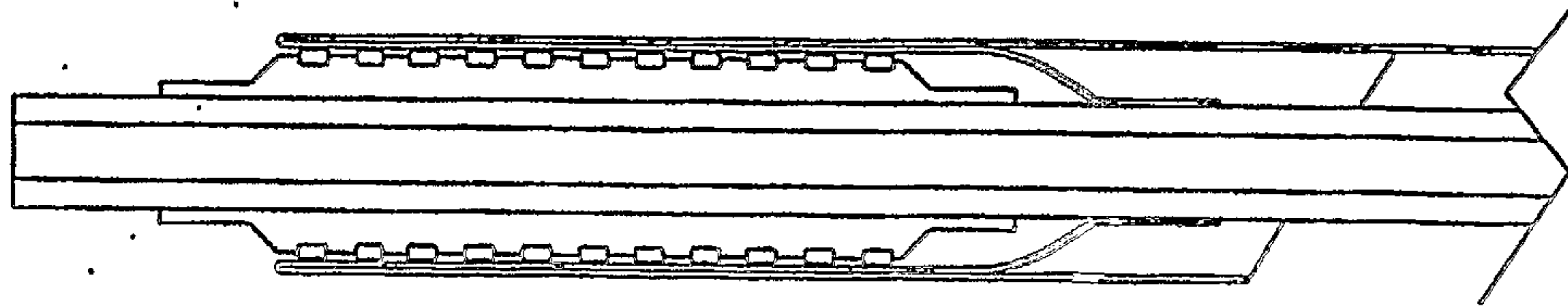

FIG. 9A

10/13

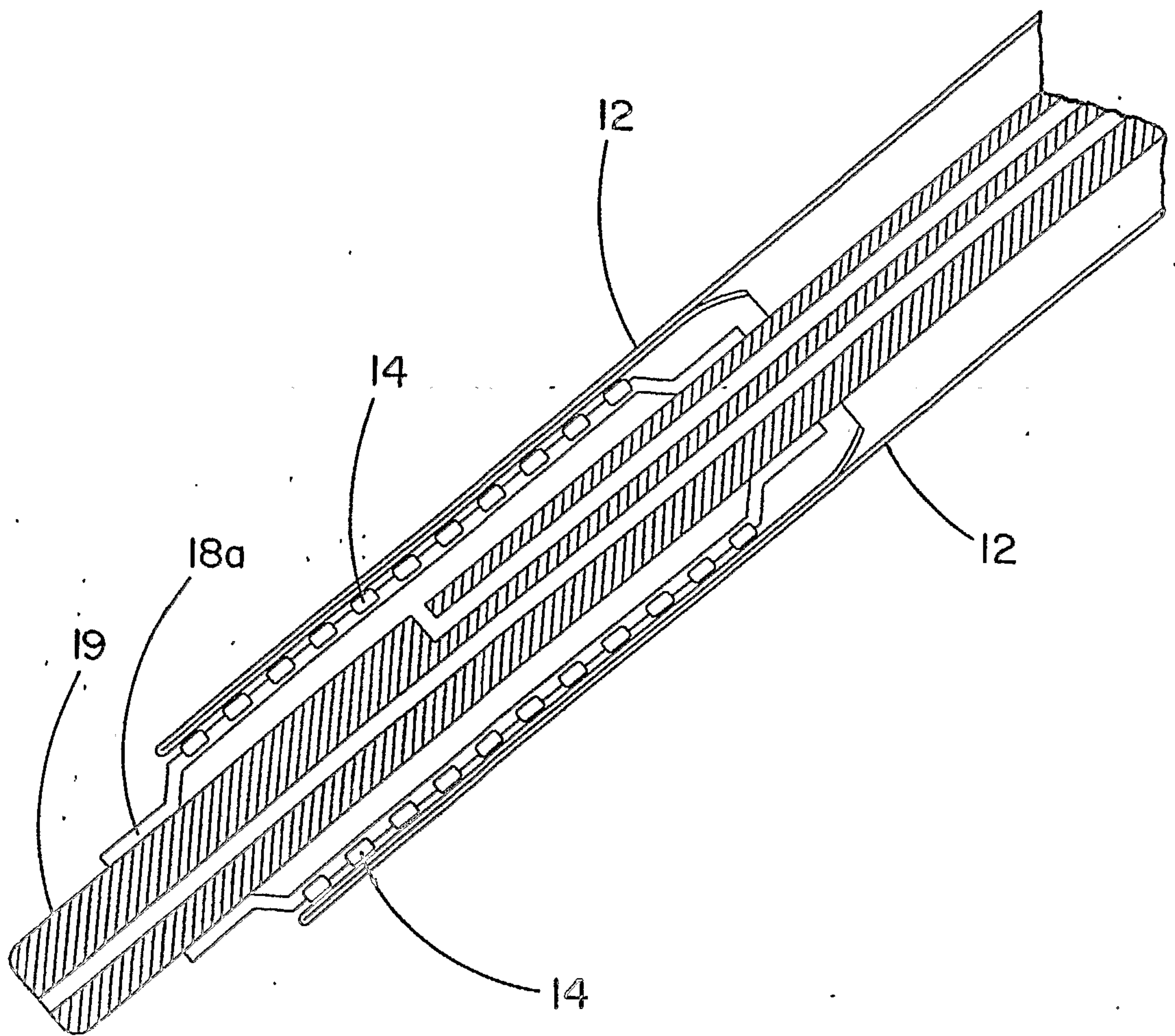

FIG. 10

11/13

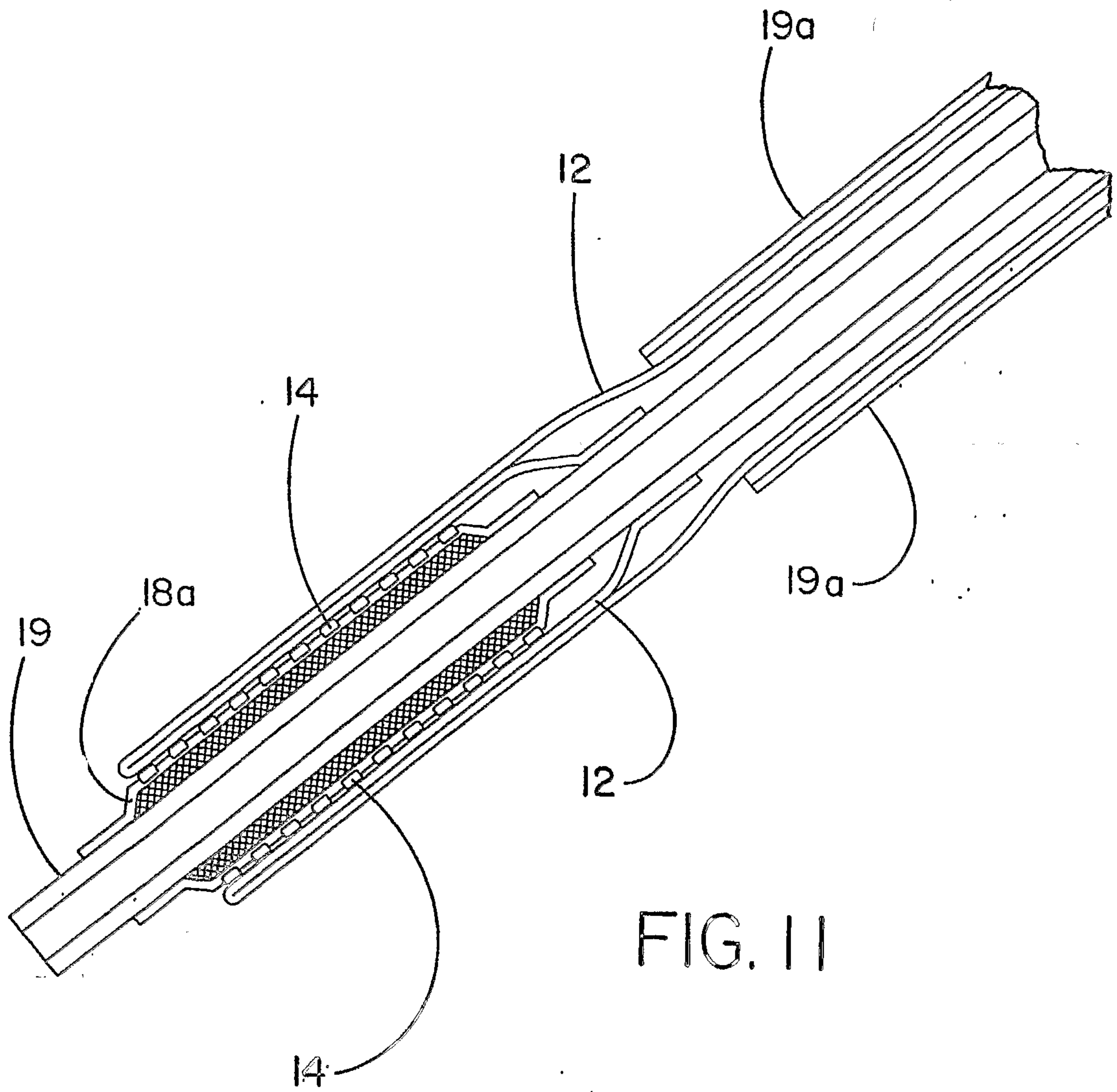

FIG. 11

12/13

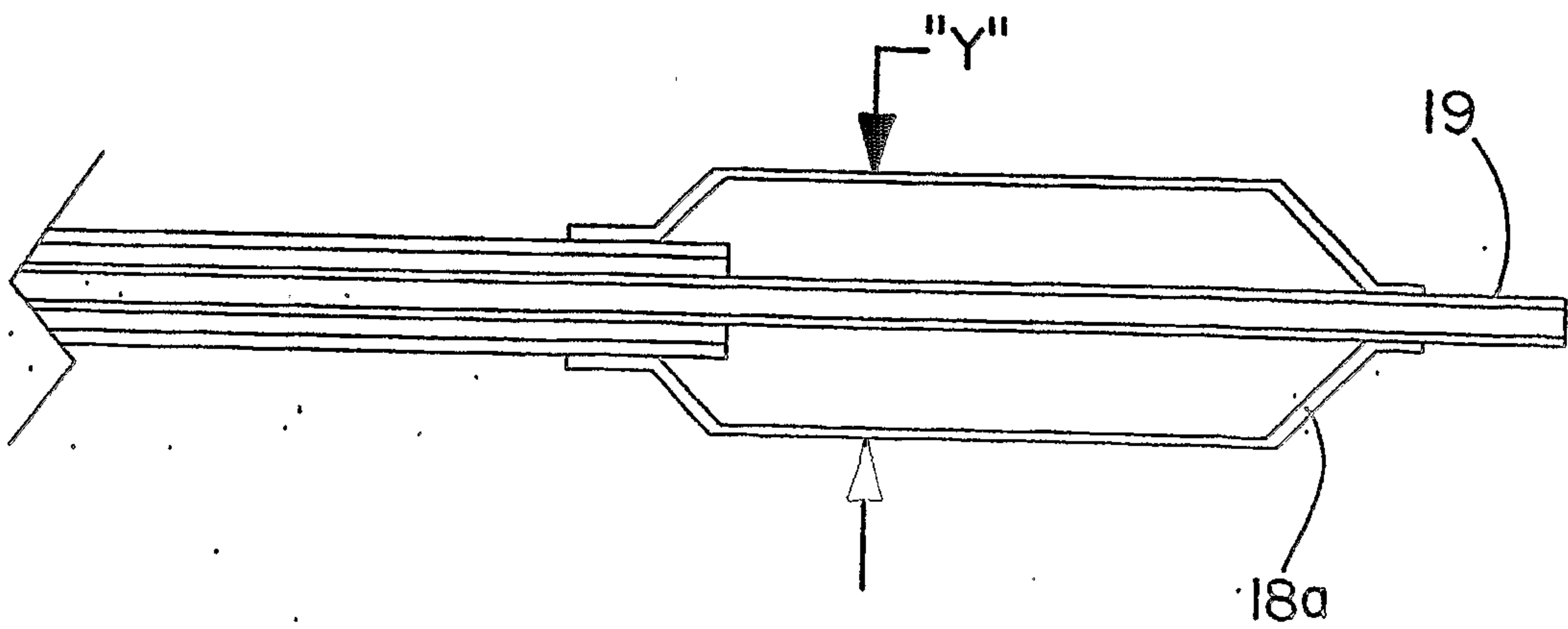
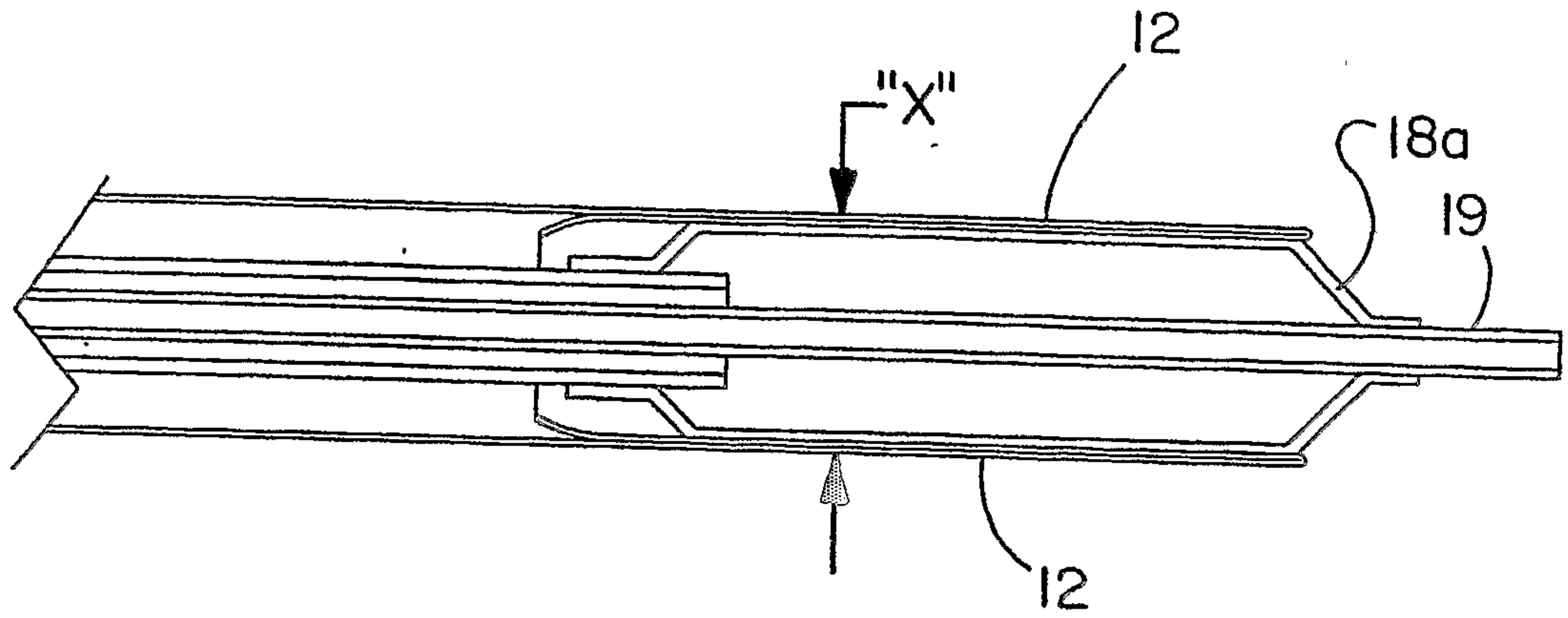

FIG. 12

13/13

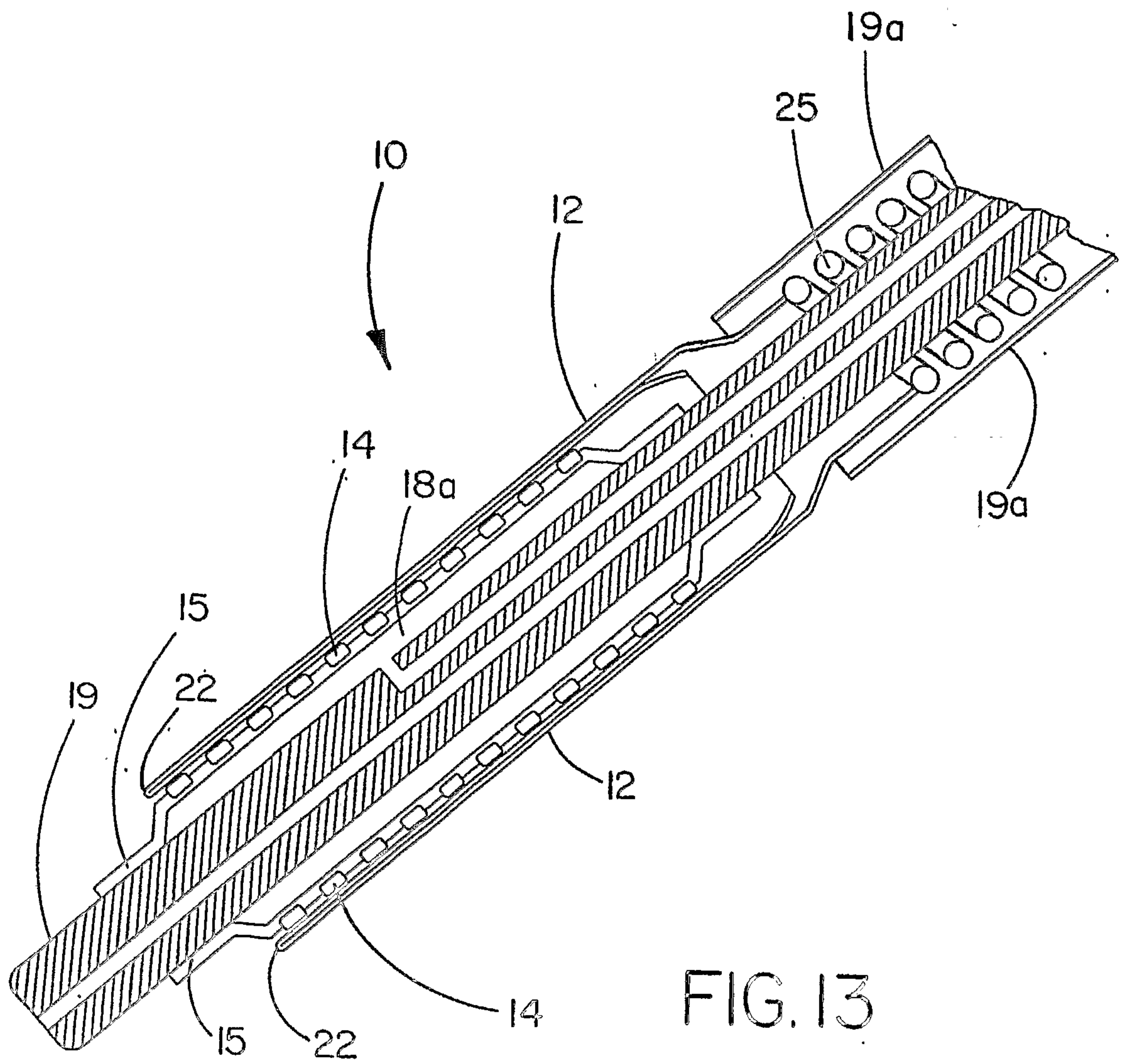

FIG. 13

