

H. H. GIBSON.

Improvement in Cultivators.

No. 132,277.

Patented Oct. 15, 1872.

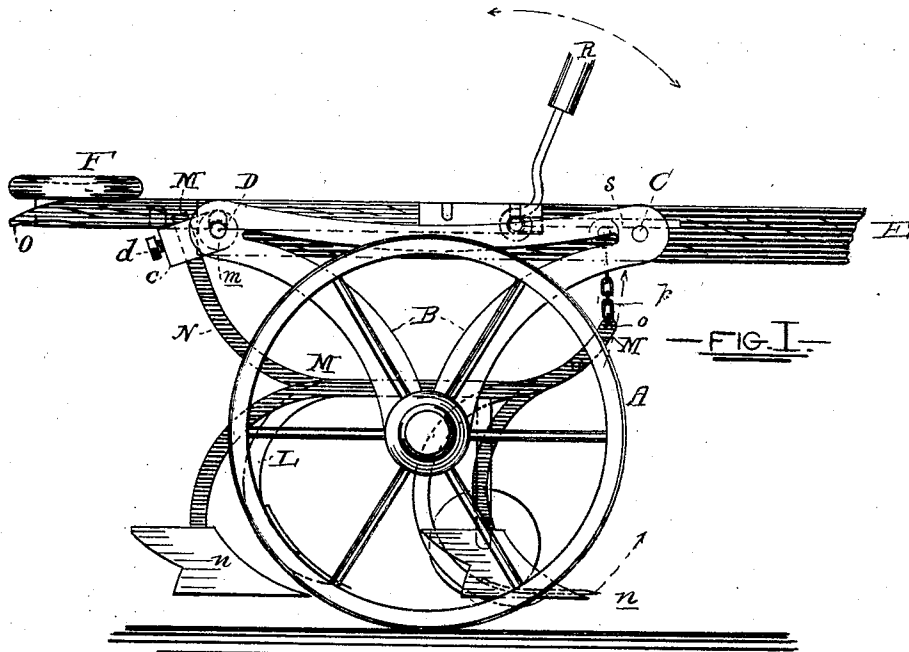

FIG. I.

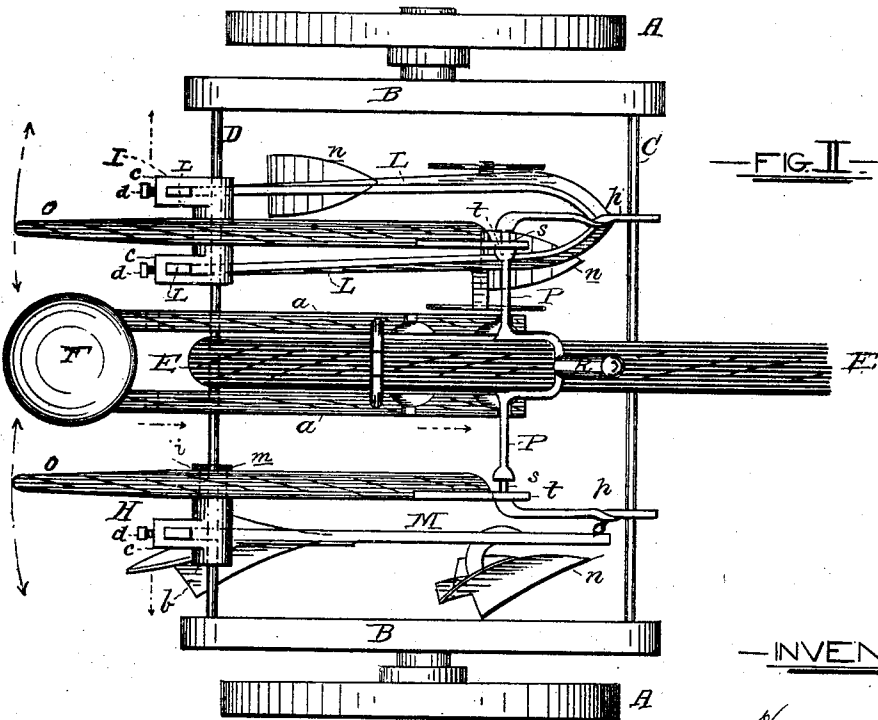

FIG. II.

INVENTOR.

Henry H. Gibson  
by his attys.  
Cox and Cox

WITNESSES:

Geo. H. Howard.  
E. A. Newman

# UNITED STATES PATENT OFFICE.

HENRY H. GIBSON, OF QUINCY, ILLINOIS.

## IMPROVEMENT IN CULTIVATORS.

Specification forming part of Letters Patent No. 132,277, dated October 15, 1872.

*To all whom it may concern:*

Be it known that I, HENRY H. GIBSON, of Quincy, Illinois, have invented a new and useful Improvement in Cultivators, of which the following is a specification:

### *Nature and Objects of the Invention.*

The invention relates to that class of plows termed cultivators, and is provided with plow-shares, which are capable of both perpendicular and lateral movement, the vertical movement being effected by means of a lever projecting above the upper part of the device and operating a double crank, the ends of which are connected by chains with the front extremities of the plow-beams, whereby the beams and shares may be elevated. The lateral movement is effected by means of levers, the handles of which project to the rear of the device and operate slides to which the rear of the plow-beams are attached, the slides moving upon a rod common to both sides of the device. The object of the invention is to furnish a cultivator or plow the depth of and distance between whose furrows, as well as the direction of the plow-shares, may be regulated by the means hereinafter specified. The device may also be employed as a breaking or common plow.

### *Description of the Accompanying Drawing.*

Figure I is a side elevation, and Fig. II is a plan view.

### *General Description.*

A in the accompanying drawing represents the wheels which revolve on short axles projecting outward from the lower angle of the triangular frames B, which are connected with each other by two rods, C and D. The rod C connects the upper front angles of the frames B, and serves to furnish a rest for the front extremities of the double crank P, and also affords a means of attaching a tongue, as in the present instance, or thills to the device. The rod D connects the upper rear angles of the frames B, and affords a rear attachment for the tongue E or thills, also as a rear support for the movable seat F, which is provided on each side with parallel arms *a*, having suitable recesses above and below to receive the rod D and crank. This seat is placed directly in rear

of the tongue E, the distance between its arms being slightly greater than the width of the tongue, that portion of which in the rear of the rod C is inclosed on two sides by the arms *a*. On the rod D are placed the sliding blocks H and I, one on each side of the seat F. These blocks are constructed as follows: If intended to receive the extremity of but one plow-beam they may be made of the shape of the block H—that is, having a circular aperture, *b*, running through its entire length through which the rod D passes, and by means of which the block H moves upon the rod D. The block H is provided with a shoulder, *c*, which, when the block is in position, projects to the rear, and is provided with a rectangular vertical slot, through which passes the upper rear extremity of the plow-beam N, where it is held in the desired position by means of the set-screw *d*. That part of the block H nearest the seat F is provided with a circular groove, *i*, to receive the staple *m*, which connects it with the lever O. The block I is used when there are two plow-beams or a plow-beam having two upper rear extremities, and is substantially the same as block H, except that it has the shoulder *c* on each side and a circular groove at its center. The plow-beams L M may be made single or double and provided with any kind of plow-shares, *n*, in L and M; also, with rotating sod-cutters, as shown in M. The beams have a rear upward and downward curve. The extremity of the former part passes through the mortise in the shoulder *c* of the block H or I. The extremity of the latter curve is provided with a share placed so that its foot is a proper distance above the plane of the lower surface of the wheels A. The plow-beam N has an upward curve in front, that extremity having an aperture and link, *o*, through which passes one end of a chain, *p*, the other end of the chain being secured to the front extremity of the double crank P. The lever O is connected by means of the staple *m* with the block H or I, and projects forward in about the same horizontal plane as the tongue E, its front extremity having a metal plate with a horizontal slot, *s*, which passes over the neck *t* in the double crank P. The front extremities of the double crank P rest upon the upper surface of the rod C at points about equidistant from the tongue E.

A short distance in rear of the bar C the crank P is provided with a loop to receive the upper end of the chain *p*. The center of the crank passes through the tongue E, on each side of which is placed the neck *t*, and is provided with a vertical lever, R, the lower part of which is open and secured on each side of the tongue E to the crank P in such position that when the lever R is forced backward and downward the front extremities of the double crank P are elevated.

*Operation.*

The propelling power being attached and the machine in motion, when it is desired to widen the distance between the furrows the handle of the lever O is moved respectively toward the nearest frame B. A contrary movement serves to widen the distance between the furrows, as in either case the levers O swinging laterally upon the double crank P, when operated, move the block H or I, to which the plow-beam is attached, thus causing the shares on the lower end of the plow-beam to move in a different line. When it is desired to lessen the depth of the furrow or furrows the lever

R is drawn back, thus turning the crank P in a similar direction and elevating its front extremities, to which are attached the chains *p*, having their lower ends secured to the front part of the plow-beams. Thus, by elevating the front parts of the cranks, the chains are drawn taut and the beams and shares elevated.

What I claim as my invention, and desire to secure by Letters Patent, is—

1. The blocks H and I provided with the shoulders *c* and set-screw *d*, for the uses and purposes shown and specified.

2. The combination of the levers O, blocks H and I, rods D and C, plow-beams N, chains *p*, crank P, lever R, and frames B, for the uses and purposes substantially as shown and described.

In testimony that I claim the foregoing improvement in cultivators, as above described, I have hereunto set my hand and seal this 13th day of March, 1872.

HENRY H. GIBSON. [L. s.]

Witnesses:

E. A. ROGERS,  
W. D. TAPPE.