

*J. West,  
 Valve.*

*No. 109476.*

*Patented Nov. 22. 1870.*

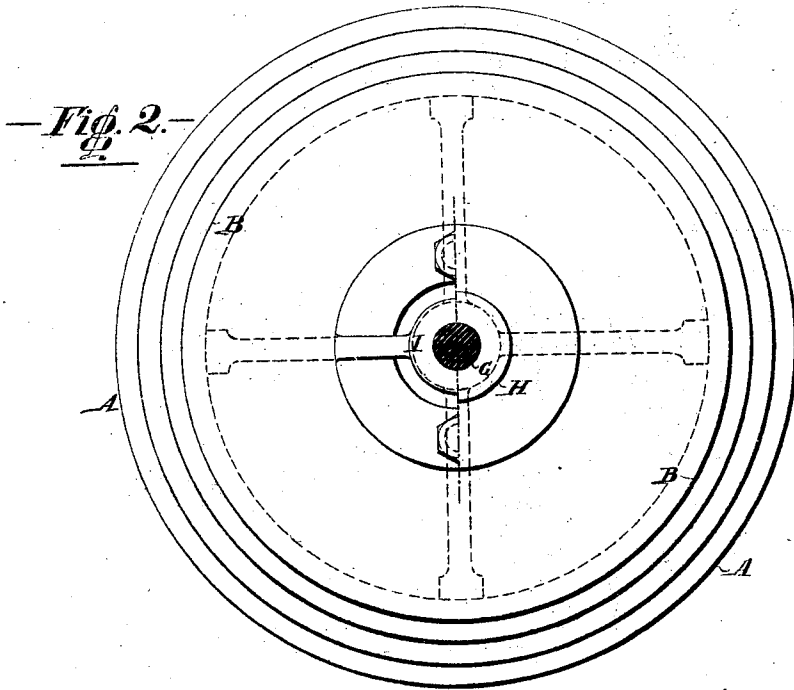
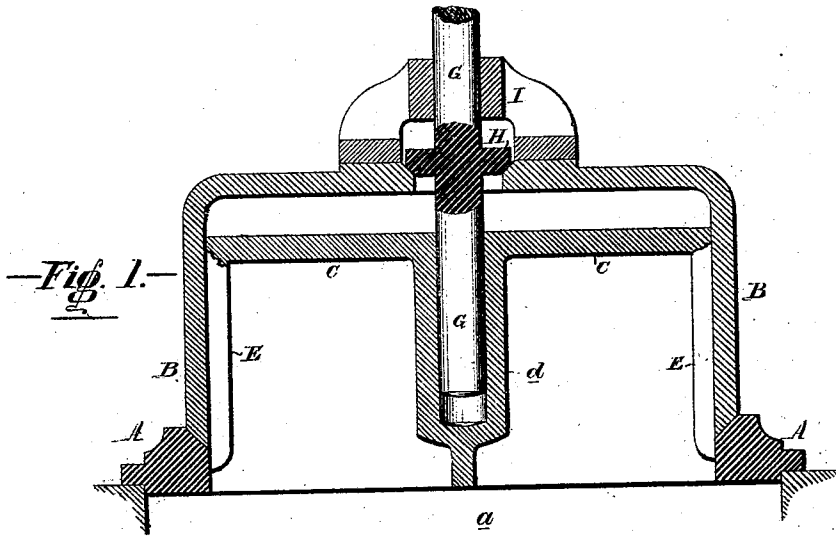

Witnesses { *Geo. B. Harding.*  
*John Parker*

*John West*  
*By his Atty*  
*Howson & Co*

# UNITED STATES PATENT OFFICE.

JOHN WEST, OF BETHLEHEM, PENNSYLVANIA.

## IMPROVEMENT IN VALVES.

Specification forming part of Letters Patent No. 109,476, dated November 22, 1870.

### *To all whom it may concern:*

Be it known that I, JOHN WEST, of Bethlehem, in the county of Northampton, State of Pennsylvania, have invented an Improved Valve, of which the following is a specification.

My invention relates to an improvement in valves to be operated against the pressure of steam, water, gases, or other fluids or liquids in a chamber or chest, my improved valve being provided with a supplementary or release valve, and being otherwise so constructed as to be nearly balanced when the valve is closed.

The main object of my invention is to avoid the defects of double-seated or double-disk, or, as they are termed, "double-seat" valves, which, owing to unequal expansion, are liable to leak, as fully explained hereinafter.

In the accompanying drawings, Figure 1 is a vertical section of my improved valve, and Fig. 2 a plan view of the same.

A is an annular seat, secured to the edge of an opening, *a*, into which steam, water, gas, or other fluid or liquid has to be admitted; and B is an inverted cup-shaped valve, the lower beveled edge of which is adapted to a similarly-beveled bearing on the seat A.

C is a circular plate or disk, over which the valve fits snugly, but so as to slide freely, this disk being in the present instance united by any desired number of webs, E, to the annular seat A, the webs radiating from a central hub, *d*, which receives and guides the operating valve-spindle G. The disk, however, may be supported independently of the seat, or in any manner which the application of the valve may suggest as the most appropriate. On this spindle is a small supplementary or release valve, H, adapted to a seat on the edge of an opening in the top of the main valve B, to which is secured the guide I for the valve-spindle, this guide being so arranged as to permit the spindle and its valve H to have a limited vertical play independently of the said main valve.

The valve, with its seat, is supposed to be contained in a chamber or chest, to which steam, water, gases, or other fluids or liquids, under pressure, have free admission. On raising the spindle G the valve H will be elevated from its seat, and the fluids or liquids will enter the space between the top of the main valve and the disk C before the said main valve is disturbed. Hence when the valve H comes in contact with the guide I, and the upward move-

ment of the spindle is continued to raise the said main valve, all the resistance the spindle meets with is the weight of the valve itself in addition to a pressure of the fluid or liquid on the limited annular area of the valve at its seat, whereas in the absence of the supplementary or release valve, and in case the spindle should be connected directly to the main valve, pressure would be exerted on the entire area of the same to resist its upward movement. In other words, my improved valve is so nearly balanced when it has to be elevated that the valve-spindle and the mechanism for operating the same may be light and inexpensive, while the consumption of power to operate the valve will be immaterial. In this respect my improved valve possesses all the advantages of the well-known double-seat valve—that is, a valve which is nearly balanced by having two seats. A double-seat valve, however, is defective in this respect, although it may be ground perfectly true to both seats in the first instance, the expansion of the valve and its seats may be unequal, and hence, while it bears tightly on one seat, it may be free from contact with the other, and consequently may permit leakage there. My improved balanced valve, or, as it may be termed, "single-seat" valve, has but one seat, so that no leakage can occur. On raising the main valve the fluid or liquid will have a free passage between the lower edge of the valve and its seat, and past the web E to the opening *a*, and on depressing the spindle the main valve will come in contact with its seat before the supplementary valve reaches its seat.

I claim—

The main valve B and its supplementary or release valve H, attached to the operating spindle, and having a limited movement independently of the main valve, in combination with the plate or disk C, or other resisting medium, to the space between which and the top of the said main valve steam or other fluid is admitted on raising the supplementary valve.

In testimony whereof I have signed my name to this specification in the presence of two subscribing witnesses.

JOHN WEST.

Witnesses:

H. HOWSON,  
JNO. B. HARDING.