



(86) Date de dépôt PCT/PCT Filing Date: 2013/09/24  
 (87) Date publication PCT/PCT Publication Date: 2014/05/15  
 (45) Date de délivrance/Issue Date: 2021/03/16  
 (85) Entrée phase nationale/National Entry: 2015/01/28  
 (86) N° demande PCT/PCT Application No.: US 2013/061285  
 (87) N° publication PCT/PCT Publication No.: 2014/074231  
 (30) Priorité/Priority: 2012/09/25 (US61/705,411)

(51) Cl.Int./Int.Cl. *A61M 39/22* (2006.01),  
*A61M 1/36* (2006.01), *F16K 11/00* (2006.01),  
*F16K 35/04* (2006.01)  
 (72) Inventeurs/Inventors:  
SCHLAEPER, CHRISTIAN, DE;  
PETER, HARALD, DE;  
CRNKOVICH, MARTIN JOSEPH, US  
 (73) Propriétaires/Owners:  
FRESENIUS MEDICAL CARE HOLDINGS, INC., US;  
FRESENIUS MEDICAL CARE DEUTSCHLAND GMBH,  
DE  
 (74) Agent: SMART & BIGGAR LLP

(54) Titre : VANNES D'INVERSION DU FLUX SANGUIN ET SYSTEMES ASSOCIES

(54) Title: BLOOD FLOW REVERSAL VALVES AND RELATED SYSTEMS

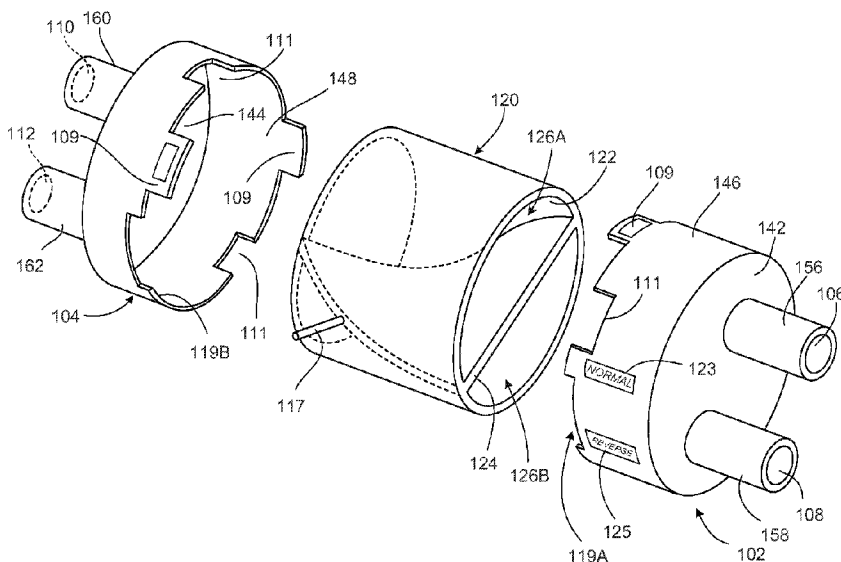

(57) **Abrégé/Abstract:**

This disclosure relates to blood flow reversal valves and related systems and methods. The blood flow reversal valve includes a first member (102) having a first passage and a second passage, and a second member (104) having a first passage and a second passage. The first and second members are rotatably fixed relative to one another such that the first passage of the first member is aligned with the first passage of the second member and the second passage of the first member is aligned with the second passage of the second member. A flow directing element (120, 320) is disposed in the cavity (105) and is moveable relative to the first and second members between a first position in which the first passage of the first member and the first passage of the second member are fluidly connected and a second position in which the first passage of the first member and the second passage of the second member are fluidly connected.

(12) INTERNATIONAL APPLICATION PUBLISHED UNDER THE PATENT COOPERATION TREATY (PCT)

(19) World Intellectual Property  
Organization  
International Bureau(43) International Publication Date  
15 May 2014 (15.05.2014)(10) International Publication Number  
**WO 2014/074231 A1**

## (51) International Patent Classification:

A61M 39/22 (2006.01) F16K 35/04 (2006.01)  
A61M 1/36 (2006.01) F16K 11/00 (2006.01)

## (21) International Application Number:

PCT/US2013/061285

## (22) International Filing Date:

24 September 2013 (24.09.2013)

## (25) Filing Language:

English

## (26) Publication Language:

English

## (30) Priority Data:

61/705,411 25 September 2012 (25.09.2012) US

(71) Applicants: **FRESENIUS MEDICAL CARE HOLDINGS, INC.** [US/US]; 920 Winter Street, Waltham, Massachusetts 02451-1457 (US). **FRESENIUS MEDICAL CARE DEUTSCHLAND GMBH** [DE/DE]; Else-Kroener-Strasse 1, 61352 Bad Homburg (DE).

(72) Inventors: **SCHLAEPER, Christian**; Niddastrasse 2, 61273 Wehrheim (DE). **PETER, Harald**; Haardtberg 11, 97422 Schweinfurt (DE). **CRNKOVICH, Martin Joseph**; 3436 Cassena Drive, Walnut Creek, California 94598 (US).

(74) Agent: **HAMLIN, Michael R.**; Fish & Richardson P.C., P.O. Box 1022, Minneapolis, Minnesota 55440-1022 (US).

(81) Designated States (unless otherwise indicated, for every kind of national protection available): AE, AG, AL, AM,

AO, AT, AU, AZ, BA, BB, BG, BH, BN, BR, BW, BY, BZ, CA, CH, CL, CN, CO, CR, CU, CZ, DE, DK, DM, DO, DZ, EC, EE, EG, ES, FI, GB, GD, GE, GH, GM, GT, HN, HR, HU, ID, IL, IN, IS, JP, KE, KG, KN, KP, KR, KZ, LA, LC, LK, LR, LS, LT, LU, LY, MA, MD, ME, MG, MK, MN, MW, MX, MY, MZ, NA, NG, NI, NO, NZ, OM, PA, PE, PG, PH, PL, PT, QA, RO, RS, RU, RW, SA, SC, SD, SE, SG, SK, SL, SM, ST, SV, SY, TH, TJ, TM, TN, TR, TT, TZ, UA, UG, US, UZ, VC, VN, ZA, ZM, ZW.

(84) Designated States (unless otherwise indicated, for every kind of regional protection available): ARIPO (BW, GH, GM, KE, LR, LS, MW, MZ, NA, RW, SD, SL, SZ, TZ, UG, ZM, ZW), Eurasian (AM, AZ, BY, KG, KZ, RU, TJ, TM), European (AL, AT, BE, BG, CH, CY, CZ, DE, DK, EE, ES, FI, FR, GB, GR, HR, HU, IE, IS, IT, LT, LU, LV, MC, MK, MT, NL, NO, PL, PT, RO, RS, SE, SI, SK, SM, TR), OAPI (BF, BJ, CF, CG, CL, CM, GA, GN, GQ, GW, KM, ML, MR, NE, SN, TD, TG).

## Declarations under Rule 4.17:

- as to applicant's entitlement to apply for and be granted a patent (Rule 4.17(ii))
- as to the applicant's entitlement to claim the priority of the earlier application (Rule 4.17(iii))

## Published:

- with international search report (Art. 21(3))

[Continued on next page]

(54) Title: BLOOD FLOW REVERSAL VALVES AND RELATED SYSTEMS

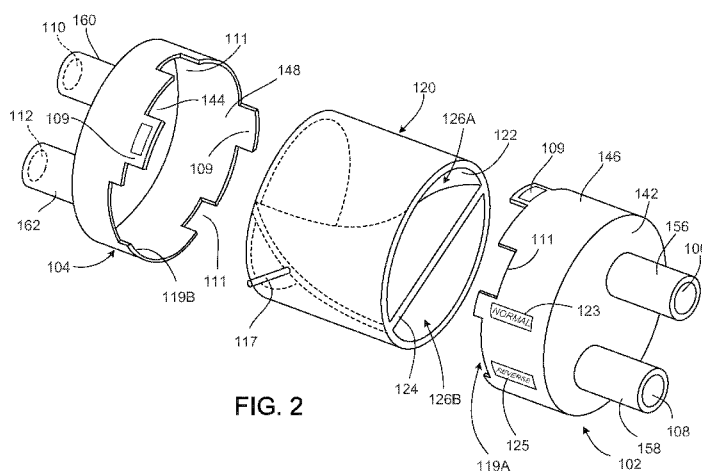

FIG. 2

(57) Abstract: This disclosure relates to blood flow reversal valves and related systems and methods. The blood flow reversal valve includes a first member (102) having a first passage and a second passage, and a second member (104) having a first passage and a second passage. The first and second members are rotatably fixed relative to one another such that the first passage of the first member is aligned with the first passage of the second member and the second passage of the first member is aligned with the second passage of the second member. A flow directing element (120, 320) is disposed in the cavity (105) and is moveable relative to the first and second members between a first position in which the first passage of the first member and the first passage of the second member are fluidly connected and a second position in which the first passage of the first member and the second passage of the second member are fluidly connected.

**WO 2014/074231 A1** 

---

- *before the expiration of the time limit for amending the claims and to be republished in the event of receipt of amendments (Rule 48.2(h))*

**BLOOD FLOW REVERSAL VALVES AND RELATED SYSTEMS****TECHNICAL FIELD**

This invention relates to blood flow reversal valves and related systems and methods.

**BACKGROUND**

5 Many modern medical procedures use tubing sets of varying complexity to withdraw fluid from a patient, or to administer fluid to a patient, or to do both. One example of such a procedure is hemodialysis. In hemodialysis, the patient's blood is cleansed by drawing it out of the patient through a blood access site, typically via a catheter, and passing it through an artificial kidney (often called a "dialyzer"). The  
10 artificial kidney includes a semi-permeable membrane which removes impurities and toxins by a process of diffusion. The purified blood is then returned to the patient. An extracorporeal circuit including a pump and hemodialysis tubing set is typically used to transport the blood between the blood access site and the artificial kidney.

Many of the tubing sets used in medical procedures involving extracorporeal  
15 treatment of fluid, such as hemodialysis, are configured so that fluid can flow through the system in a desired direction during the medical procedure. A pumping device can be used to control the fluid flow rate in the system. In hemodialysis, for example, a peristaltic pump is typically used to draw blood from the patient and move the blood through the tubing set during the treatment procedure. During hemodialysis, blood is  
20 initially drawn from the patient's blood access (e.g., a vein or an artery, but more typically an arteriovenous graft or fistula) and flows through a series of connected tubing segments to the artificial kidney for cleansing. After passing through the artificial kidney, the blood then flows through other tubing segments that return the blood to the patient. Thus, there is generally a continuous circuit of blood flowing from  
25 the patient, through the artificial kidney, and then back to the patient during treatment.

During hemodialysis, blood is generally drawn from an upstream position in the blood access and then returned to a downstream position in the blood access. However, it has been found to be advantageous, for limited time periods, to reverse the direction that blood is received from and returned to the patient during hemodialysis. When the blood flow is reversed, blood is initially drawn from a downstream position in the blood access. The blood then flows through tubing segments to the artificial kidney for treatment before it is returned to the upstream position in the blood access. Typically this procedure is carried out by trained clinical personnel, e.g., dialysis clinicians. When the blood flow is reversed, any of various parameters, such as blood access flow rate, can be measured or derived from measurements. The data can provide useful information about the patient's condition and the effectiveness of the treatment. For example, practitioners can use information gathered during periods of reversed blood flow to evaluate the condition of the blood access, to get advanced warning on other health problems, such as access restrictions, and to prescribe preventive measures, such as blood access revision or replacements, which are generally needed after a few years of continuous dialysis.

## SUMMARY

According to an aspect of the present invention, there is provided a blood flow reversal valve comprising: a first member having a first passage and a second passage; a second member having a first passage and a second passage, the first and second members being rotatably fixed relative to one another such that the first passage of the first member is aligned with the first passage of the second member and the second passage of the first member is aligned with the second passage of the second member; and a flow directing element disposed in a cavity formed between the first and second members, the flow directing element comprising a planar member extending through a semi-helical path in the cavity from a first end of the cavity to a second end of the cavity, the flow directing element being moveable relative to the first and second members between a first position in which the first passage of the first member and the first passage of the second member are fluidly connected and the second passage of the first member and the second passage of the second member are fluidly connected, and a second position in which the first passage of the first member and the second passage of the second member are fluidly connected and the second passage of the first

member and the first passage of the second member are fluidly connected wherein the first and second members of the blood flow reversal valve are configured to remain rotatably fixed with respect to one another while the flow directing element moves from the first position to the second position.

5           According to another aspect of the present invention, there is provided a blood treatment system comprising: a blood flow reversal valve comprising a first member having a first passage and a second passage; a second member having a first passage and a second passage, the first and second members being rotatably fixed relative to one another such that the first passage of the first member is aligned with the first passage of the second member  
10 and the second passage of the first member is aligned with the second passage of the second member; and a flow directing element disposed in a cavity formed between the first and second members, the flow directing element comprising a planar member extending through a semi-helical path in the cavity from a first end of the cavity to a second end of the cavity, the flow directing element being moveable relative to the first and second members between a  
15 first position in which the first passage of the first member and the first passage of the second member are fluidly connected and the second passage of the first member and the second passage of the second member are fluidly connected, and a second position in which the first passage of the first member and the second passage of the second member are fluidly  
20 connected and the second passage of the first member and the first passage of the second member are fluidly connected; and a blood treatment device comprising: a valve retention element configured to secure the blood flow reversal valve to the blood treatment device; and an actuator configured to move the flow directing element of the blood flow reversal valve from the first position to the second position, wherein the first and second members of the  
25 blood flow reversal valve are configured to remain rotatably fixed with respect to one another while the flow directing element moves from the first position to the second position.

          According to another aspect, there is provided a method of operating a blood flow reversal valve that comprises a first member having a first passage and a second passage, a second member rotationally fixed relative to the first member and having a first passage and a second passage, and a flow directing element disposed in a cavity formed between the first  
30 and second members, the flow directing element comprising a planar

member extending through a semi-helical path in the cavity from a first end of the cavity to a second end of the cavity, the method comprising: moving the flow directing element of the blood flow reversal valve from a first position in which the first passage of the first member and the first passage of the second member are fluidly connected and the second passage of the first member and the second passage of the second member are fluidly connected to a second position in which the first passage of the first member and the second passage of the second member are fluidly connected and the second passage of the first member and the first passage of the second member are fluidly connected, wherein the first and second members of the blood flow reversal valve remain fixed with respect to one another while the flow directing element moves from the first position to the second position.

In one aspect of the invention, a blood flow reversal valve includes a first member having a first passage and a second passage and a second member having a first passage and a second passage. The first and second members are rotatably fixed relative to one another such that the first passage of the first member is aligned with the first passage of the second member and the second passage of the first member is aligned with the second passage of the second member. A flow directing element is disposed in a cavity formed between the first and second members. The flow directing element is moveable relative to the first and second members between a first position in which the first passage of the first member and the first passage of the second member are fluidly connected and the second passage of the first member and the second passage of the second member are fluidly connected, and a second position in which the first passage of the first member and the second passage of the second member are fluidly connected and the second passage of the first member and the first passage of the second member are fluidly connected.

In another aspect of the invention, a blood treatment system includes a blood flow reversal valve including a first member having a first passage and a second passage and a second member having a first passage and a second passage. The first and second members are rotatably fixed relative to one another such that the first  
5 passage of the first member is aligned with the first passage of the second member and the second passage of the first member is aligned with the second passage of the second member. A flow directing element of the blood flow reversal valve is disposed in a cavity formed between the first and second members, the flow directing element being  
10 moveable relative to the first and second members between a first position in which the first passage of the first member and the first passage of the second member are fluidly connected and the second passage of the first member and the second passage of the second member are fluidly connected, and a second position in which the first passage of the first member and the second passage of the second member are fluidly connected and the second passage of the first member and the first passage of the second member  
15 are fluidly connected. The system further includes a blood treatment device including a valve retention element configured to secure the blood flow reversal valve to the blood treatment device and an actuator configured to move the flow directing element of the blood flow reversal valve from the first position to the second position.

In an additional aspect, a method of reversing blood flow uses a  
20 blood flow reversal valve that includes a first member having a first passage and a second passage, a second member rotationally fixed relative to the first member and having a first passage and a second passage, and a flow directing element disposed in a cavity formed between the first and second members. The method includes moving the flow directing element of the blood flow reversal valve from a first position in which  
25 the first passage of the first member and the first passage of the second member are fluidly connected and the second passage of the first member and the second passage of the second member are fluidly connected to a second position in which the first passage of the first member and the second passage of the second member are fluidly connected and the second passage of the first member and the first passage of the second member  
30 are fluidly connected. The first and second members of the blood flow reversal valve remain fixed with respect to one another while the flow directing element moves from the first position to the second position.

Implementations can include one or more of the following features.

In some implementations, the flow directing element is rotatable about a longitudinal axis of the blood flow reversal valve.

In certain implementations, the first passages are aligned along an axis that is  
5 substantially parallel to the longitudinal axis, and the second passages are aligned along  
an axis that is substantially parallel to the longitudinal axis.

In some implementations, the flow directing element defines a first flow path  
and a second flow path.

In certain implementations, the first flow path fluidly connects the first passage  
10 of the first member to the first passage of the second member and the second flow path  
fluidly connects the second passage of the first member to the second passage of the  
second member when the flow directing element is in the first position.

In some implementations, the first flow path fluidly connects the second  
passage of the first member to the first passage of the second member and the second  
15 flow path fluidly connects the first passage of the first member to the second passage of  
the second member when the flow directing element is in the second position.

In certain implementations, the flow directing element is substantially  
cylindrical.

In some implementations, the first and second flow paths are substantially semi-  
20 helical.

In certain implementations, each of the first and second flow paths has a kidney-  
shaped cross-sectional area.

In some implementations, the flow directing element includes a body defining a  
central lumen and a partition extending through the lumen to form the first and second  
25 flow paths.

In certain implementations, the partition extends along a curved path between a  
first end of the body and a second end of the body.

In some implementations, the partition extends along a substantially semi-  
helical path between the first end of the body and the second end of the body.

30 In certain implementations, each of the first and second flow paths has a  
substantially half-circular cross-sectional area.

In some implementations, the partition twists by about 5 degrees to about 180 degrees from a first end of the body to a second end of the body.

In certain implementations, the partition twists by about 90 degrees from the first end of the body to the second end of the body.

5 In some implementations, the blood flow reversal valve further includes a projection that extends radially from the flow directing element.

In certain implementations, the projection extends through a slot that is defined by at least one of the first and second members.

10 In certain implementations, the first and second members cooperate to define the slot.

In some implementations, the slot extends circumferentially about the first and second members.

15 In certain implementations, the projection extends radially a sufficient distance to engage an actuator of a blood treatment machine when the blood flow reversal valve is connected to the blood treatment machine.

In some implementations, the valve retention element includes resilient fingers configured to releasably engage fluid line connectors of the blood flow reversal valve.

20 In certain implementations, the actuator defines an opening configured to receive a projection that extends radially from the flow directing element of the blood flow reversal valve.

In some implementations, the actuator is configured to rotate the flow directing element.

In certain implementations, the blood treatment system further includes a controller programmed to move the actuator.

25 In some implementations, the controller is programmed to move the actuator at a predetermined time during a blood treatment.

In certain implementations, moving the flow directing element from the first position to the second position includes rotating the flow directing element relative to first and second members.

30 In some implementations, the flow directing element is moved from the first position to the second position by an actuator of a blood treatment machine.

In certain implementations, the method further includes transmitting a signal from a controller of the blood treatment machine to the actuator to move the flow directing element.

5 In some implementations, the method further includes moving the flow directing element from the second position back to the first position.

In certain implementations, the method further includes running a blood pump to force blood through the blood flow reversal valve.

In some implementations, the method further includes stopping the blood pump prior to rotating the flow directing element from the first position to the second  
10 position.

In certain implementations, the method further includes measuring one or more parameters of blood flowing through the blood flow reversal valve.

Implementations can include one or more of the following advantages.

Blood flow reversal valves described herein can advantageously reverse the  
15 blood flow through fluid lines connected thereto without requiring repositioning or twisting of the fluid lines relative to one another. Reduced repositioning or twisting of the fluid lines can result in less kinking or binding of the fluid lines and, as a result, better flow through the fluid lines.

Certain blood flow reversal valves described herein can be connected to a blood  
20 treatment machine (e.g., a hemodialysis machine) for automatically reversing blood flow. As a result, blood flow reversal can be achieved more easily with automated blood flow reversal valves described herein than with certain manually operated blood flow reversal valves. Additionally, the system (e.g., a control unit or processor of the system) can be programmed to automatically reverse blood flow and take  
25 measurements at designated times throughout the treatment. As a result, such measurements can be taken at the ideal times throughout the treatment even if a clinician is not present to manually reverse the blood flow.

The details of one or more embodiments are set forth in the accompanying drawings and the description below. Other aspects, features, and advantages will be  
30 apparent from the description and drawings.



walls 146, 148 that extend from the end plates 142, 144. The first and second valve bodies 102, 104 are axially and rotationally fixed relative to one another, and the flow directing element 120 is rotatable within the cavity 105.

The first and second valve bodies 102, 104 are secured to one another by mating  
5 features in the form of tabs 109 and slots 111 that are formed around respective adjoining edges of the first and second valve bodies 102, 104 and are spaced to align with one another for assembly of the blood flow reversal valve 100. The tabs 109 and slots 111 are configured to be pressed into and coupled to one another. For example, the tabs 109 and slots 111 can include snap-in style detents, resilient fingers that deflect  
10 and lock in place to connect the first and second valve bodies 102, 104, or other interlocking features and elements to secure the valve bodies 102, 104 together.

Still referring to Figures 1 and 2, the first valve body 102 includes blood line connectors 156, 158 that extend outwardly from the end plate 142, and the second valve body 104 includes blood line connectors 160, 162 that extend outwardly from the end  
15 plate 144. Fluid passages 106, 108, 110, 112 extend through the blood line connectors 156, 158, 160, 162 and the end plates 142, 144 to provide fluid communication with the central cavity 105 of the valve 100. Because the first and second valve bodies 102, 104 are rotationally fixed relative to one another, the blood line connectors 156 and 160 are fixed in axial alignment with one another, and the blood line connectors 158 and 162  
20 are fixed in axial alignment with one another. As a result, the fluid passages 106 and 110 are axially aligned with one another, and the fluid passages 108, 112 are axially aligned with one another. However, as will be described below, the flow directing element 120 can be rotationally positioned to either fluidly connect the axially aligned fluid passage pairs (106/110 and 108/112) of the first and second valve bodies 102, 104  
25 or to fluidly connect the axially misaligned fluid passage pairs (106/112 and 108/110) of the first and second valve bodies 102, 104.

As shown in Figure 2, the first valve body 102 includes a first slot portion 119A and the second valve body 104 includes a second slot portion 119B. The first and second slot portions 119A, 119B axially align with one another when the first and  
30 second valve bodies 102, 104 are secured to one another, as shown in Figure 1, to form a slot 119. A pin 117 is secured to the flow directing element 120 and extends radially outward through the slot 119. The pin 117 can be moved along the slot 119 in order to

rotate the flow directing element 120 from a first position that causes blood to flow through the valve 100 in a normal direction to a second position that causes blood to flow through the valve 100 in a reverse direction.

As shown in Figure 2, the first valve body 102 includes visual indicators 123, 5 125 that are used to indicate the orientation of the flow directing element 120 relative to the first and second valve bodies 102, 104. Specifically, the visual indicators 123, 125 include the words "Normal" and "Reverse," respectively, applied (e.g., printed, engraved, molded, applied using stickers, or applied by other suitable methods) to portions of the cylindrical wall 146 that are adjacent opposite end regions of the slot 10 119. As a result, the user can easily determine that the flow directing element 120 is in the normal flow position when the pin 117 is adjacent the indicator 123 and can easily determine that the flow directing element 120 is in the reverse flow position when the pin 117 is adjacent the indicator 125.

Blood lines (e.g., tubing from a blood line set) can be connected to the blood 15 line connectors 156, 158, 160, 162. For example, the blood lines can be slid over the blood line connectors 156, 158, 160, 162 and secured (e.g., adhesively attached) to the blood line connectors 156, 158, 160, 162. In some implementations, the blood lines are attached to their associated blood line connectors by applying a solvent, such as cyclohexanone, to the blood line connectors and then sliding the blood lines over the 20 blood line connectors.

Referring to Figure 2, the central rotatable flow directing element 120 is arranged and configured to rotate about a longitudinal axis 115 of the flow reversal valve 100 to direct flow in a desired manner between the fluid passages 106, 108 of the first valve body 102 and the fluid passages 110, 112 of the second valve body 104. The 25 rotatable flow directing element 120 is formed of a cylindrical outer wall 122 forming an inner flow cavity, and an inner, semi-helical partition 124 that divides the inner flow cavity into a first flow path 126A and a second flow path 126B. The partition 124 is twisted about the longitudinal axis 115 to form the semi-helical profile. As a result of this configuration, the first flow path 126A and the second flow path 126B follow 30 twisted, curved profiles. The partition 124 typically has a smooth, gradual surface that twists along the semi-helical profile. The first flow path 126A and the second flow

path 126B are substantially the same shape and size, and follow similarly orientated paths through the flow directing element 120.

Along its axial length, the partition 124 rotates or twists at an angle that allows the axially aligned fluid passages 106 and 110 and the axially aligned fluid passages 5 108 and 112 to be fluidly connected when the flow directing element is in the normal flow orientation (shown in Figure 3) and that allows the axially misaligned fluid passages 106 and 112 and the axially misaligned fluid passages 108 and 110 to be fluidly connected when the flow directing element is in the reverse flow orientation (shown in Figure 4). Specifically, when the flow directing element 120 is in the normal 10 flow orientation, the flow path 126A connects the fluid passage 106 to the fluid passage 110 and the flow path 126B connects the fluid passage 108 to the fluid passage 112. When the flow directing element 120 is in the reverse flow orientation, the flow path 126B connects the fluid passage 106 to the fluid passage 112 and the flow path 126A connects the fluid passage 108 to the fluid passage 110. Since the first and second flow 15 paths 126A, 126B are semi-circular and extend circumferentially almost 180 degrees within the cylindrical outer wall 122 of the flow directing element 120, the twist angle of the partition 124 typically only needs to be large enough to overcome the width of the fluid passages, as well as the width of the partition 124. For example, the partition twist angle can be about 5 degrees to about 180 degrees (e.g., about 60 degrees to about 20 120 degrees, about 90 degrees).

The distance that the flow directing element 120 needs to be rotated in order to reverse blood flow through the valve is dependent on the twist angle of the partition 124 and the arrangement of the fluid passages. As the twist angle increases, the rotational travel distance required to reverse blood flow through the valve 100 will also 25 increase. Typically, the partition 124 is configured so that rotating the flow directing element 120 by about 5 degrees to about 180 degrees (e.g., about 60 degrees to about 120 degrees, about 90 degrees) about the longitudinal axis 115 is sufficient to reverse the blood flow.

The flow directing element 120 is sized to create a press-fit type seal within the 30 cavity 105 between the first and second valve bodies 102, 104 when the first and second valve bodies 102, 104 are secured to one another. For example, the flow directing element 120 can have an axial length that is greater than or equal to the axial

length of the cavity 105. In addition, the cylindrical wall 122 of the flow directing element 120 can have an outer diameter that is greater than or equal to the diameter of the cavity 105.

The press-fit seal can help limit inadvertent flow out of the first flow path 126A and the second flow path 126B. For example, a tight fit between the flow directing element 120 and end plates 142, 144 of the first and second valve bodies 102, 104 can help limit blood from flowing between the first and second flow paths 126A, 126B and/or help limit blood from flowing from the first and second flow paths 126A, 126B to outer regions of the cavity 105. Similarly, the tight fit between the cylindrical wall 10 122 of the flow directing element 120 and the inner surfaces of the walls 146, 148 of the first and second valve bodies 102, 104 can help to prevent blood from leaking into the circumferential space around the flow directing element 120 in the event that blood escapes one of the flow paths 126A, 126B.

The pin 117, which extends radially outward from the cylindrical outer wall 122 of the flow directing element 120, is typically integrally molded with the cylindrical outer wall 122. Alternatively, the pin 117 can be attached to the cylindrical outer wall 122 using other suitable techniques. For example, the pin-like member 117 can be attached to the cylindrical outer wall 122 using fasteners (e.g., threaded fasteners), adhesive bonds, thermal bonds, or chemical bonds.

The first and second valve bodies 102, 104 and the flow directing element 120 are typically made of one or more biocompatible high-impact thermoplastic or thermoset materials. In some implementations, the valve bodies 102, 104 are formed of acrylic-based multipolymer compound (e.g., a biocompatible high impact MMA/styrene/acrylonitrile terpolymer or similar injection moldable thermoplastic 25 compound). However, other medical grade materials, such as polycarbonate, polysulfone, or blends of these types of materials, can alternatively or additionally be used. The first and second valve bodies 102, 104 and the flow directing element 120 are typically formed using injection molding techniques. However, other techniques, such as etching and machining, can alternatively or additionally be used.

Figures 3 and 4 are cutaway perspective views illustrating the flow directing element 120 in a normal flow orientation and a reverse flow orientation, respectively. Portions of the cylindrical outer wall 122 of the flow directing element have been 30

cutaway to provide a clear view of the twisted partition 124. As shown, the flow directing element 120 can be rotated within the cavity 105 to fluidly connect the different passages with one another to reverse fluid flow within the blood flow reversal valve 100. In particular, when the flow directing element 120 is in the normal flow orientation, as shown in Figure 3, the partition 124 is positioned relative to the stationary fluid passages such that the axially aligned fluid passages 106, 110 are fluidly connected via the flow path 126A and the axially aligned fluid passages 108, 112 are fluidly connected via the flow path 126B. When the flow directing element 120 is in the reverse flow orientation, as shown in Figure 4, the partition 124 is positioned relative to the stationary fluid passages such that the axially misaligned fluid passages 106, 112 are fluidly connected via the flow path 126B and the axially misaligned fluid passages 108, 110 are fluidly connected via the flow path 126A.

Figure 5 schematically illustrates a hemodialysis system 200 including a blood line set that includes the blood flow reversal valve 100 connected to a hemodialysis machine 201. The blood flow reversal valve 100 is fitted to a valve receptacle 250 mounted along a front face of the hemodialysis machine 201. Arterial and venous blood lines 212 and 214 are connected to blood line connectors 158 and 156, respectively, of the first valve body 102, and outlet and inlet blood lines 206 and 208 are secured to blood line connectors 162 and 160, respectively, of the second valve body 104.

As shown in Figure 5, the second valve body 104 is fluidly connected to a pump 202 via the outlet blood line 206 and is fluidly connected to a dialyzer 204 via the inlet blood line 208. The pump 202 is fluidly connected to the dialyzer 204 via a connection tube 210. On the opposite side of the valve 100, the arterial and venous blood lines 212, 214 are fluidly connected to the first valve body 102 and can be connected to a patient during treatment. During treatment, as will be discussed below, the flow directing element 120 of the valve 100 can be rotated to reverse blood flow within the arterial and venous blood lines 212, 214 without reversing operation of the blood pump 202 or twisting the lines 206, 208, 212, 214.

The blood lines 206, 208, 210, 212, and 214 can be any of various types of blood lines. In some embodiments, the blood lines are formed of one or more compliant materials, such as polyvinylchloride (PVC), Di(2-ethylhexyl) phthalate

(DEHP), polyolifins, etc. However, other conventional blood line materials can alternatively or additionally be used.

The pump 202 can be any of various pumping devices capable of forcing blood through system 200. Examples of suitable pumping devices include peristaltic pumps, 5 such as those available from Sarns, Inc. (Ann Arbor, Michigan).

The dialyzer 204 can include any of various dialyzers. Examples of suitable dialyzers include Fresenius Optiflux<sup>®</sup> series dialyzers.

Referring to Figure 6, the valve receptacle 250 includes valve retention elements (e.g., resilient fingers or clamping devices) 252 that are sized and configured 10 grasp the blood flow reversal valve 100 during use. The valve retention elements 252 each have finger-like elements 253 that protrude inward towards a valve insertion area. The finger-like elements 253 are configured to grasp the blood line connectors 156, 158, 160, 162 and to help to keep the blood flow reversal valve 100 generally stationary during blood treatment and flow reversal.

15 A pin movement device or actuator 254 is located substantially in the center of the valve retention elements 252 and protrudes through a hole 256 formed in the face of the blood treatment machine. The actuator 254 has a pin slot 258 that is sized and configured to receive the pin 117 of the blood flow reversal valve 100. As shown, the actuator 254 is in the form of a rotating member 260 that, when rotated, can move the 20 pin 117 relative to the stationary blood flow reversal valve 100. The rotating member 260 is connected to a motor (e.g., an electric motor) that can rotate the rotating member 260. As a result, the actuator 254 can move the flow directing element 120 and reverse the blood flow through the valve 100.

The hemodialysis machine 201 includes a controller (e.g., a microprocessor) 25 that is electrically connected to the motor connected to the rotating member 260. Signals can be sent from the controller to the motor to operate the rotating member 260. The controller is also typically connected to a timer and/or sensors of the hemodialysis machine 201 so that the controller can receive signals from those components and operate the rotating member 260 based on the signals received from those components. 30 In some implementations, the controller is programmed to transmit signals to rotate the rotating member 260 and thus reverse blood flow through the valve 100 at designated times during treatment. In such implementations, the controller can receive signals

from the timer indicating how long the treatment has been underway and can cause the rotating member 260 to rotate when a predetermined time is reached. Alternatively or additionally, the controller can be programmed to rotate the rotating member 260 upon receiving signals indicating that readings of a sensor (e.g., a pressure sensor) are  
5 outside of a predetermined range.

Figure 7 illustrates a schematic side view of the blood flow reversal valve 100 mounted in the valve receptacle 250. As shown, the blood line connectors 156, 158, 160, 162 are clipped into their associated valve retention elements 252 so that the blood flow reversal valve 100 is held generally stationary relative to the hemodialysis  
10 machine 201 during use. The pin 117 of the valve 100 is disposed in the pin slot 258 of the rotating member 260 so that the blood flow reversal valve 100 is engaged by the valve receptacle 250 for use.

Figures 8A and 8B illustrate an exemplary method of using the hemodialysis system 200 to perform hemodialysis. Referring to Figure 8A, the arterial and venous  
15 blood lines 212 and 214 are connected to an artery and vein, respectively, of a patient. Any of various known methods can be used to connect the arterial and venous blood lines 212 and 214 to the patient. For example, the blood lines 212 and 214 can be fluidly connected to a fistula, graft or shunt implanted within a patient, which connects a vein of the patient to an artery of the patient.

To begin treatment, the valve 100 is configured in the normal flow orientation in which the arterial blood line 212 is fluidly connected with the outlet blood line 206 via the second flow path 126B of the flow directing element 120 and the venous blood line 214 is fluidly connected with the inlet blood line 208 via the first flow path 126A of the flow directing element 120. When in this position, as discussed above, the pin 117 is  
25 aligned with the indicator 123, which displays the term "Normal," to inform the clinician that valve 100 is in the normal flow position. The blood pump 202 is then activated, causing blood to be drawn from the artery of the patient through the arterial blood line 212 and the outlet blood line 206 to the pump 202. The blood is then forced through the connection line 210 to the dialyzer 204, where the blood is filtered. After  
30 exiting the dialyzer 204, the blood continues through the inlet blood line 208 and the venous line 214 to the patient. The blood re-enters the vein of the patient via the venous line 214. The blood is generally pumped through the system 100 at a flow rate

of approximately 300 ml/min. However, other flow rates are possible. The pump 202 can, for example, be configured to pump the blood at a rate of about 50 ml/min to about 600 ml/min.

As discussed above, it may be desirable at certain times during hemodialysis to  
5 reverse the flow of blood. Certain parameters can, for example, be measured in the standard flow and reversed flow configurations and compared to one another in order to determine the blood access flow rate. Examples of methods of determining blood access flow rates are described, for example, in U.S. Patent No. 5,830,365 and U.S. Patent No. 6,648,845, which are incorporated by reference herein.

10 When the dialysis system 200 determines that it is appropriate to reverse blood flow through the blood flow reversal valve 100, the pump 202 is typically briefly stopped. Once the blood flow has stopped, the controller of the dialysis system 200 sends a signal to rotating member 260 of the valve receptacle 250. The rotating member 260 is then rotated to move the pin slot 258 (i.e., to move the pin slot 258  
15 downward in the orientation shown in Figure 7) to move the pin 117. As the pin 117 moves from the normal flow position towards the reverse flow position, the partition 124 rotates within the blood flow reversal valve 100 toward a position in which it fluidly connects the fluid passages in a manner to induce a reserved flow.

After being placed in the reverse flow position illustrated in Figure 8B, the  
20 arterial blood line 212 is fluidly connected with the inlet blood line 208 via the second flow path 126B of the flow directing element 120, and the venous blood line 214 is fluidly connected with the outlet blood line 206 via the first flow path 126A of the flow directing element 120. The pump 202 is then restarted, causing blood to be drawn from the vein of the patient and drawn through the venous blood line 214 and the outlet  
25 blood line 206 to the pump 202. The blood is then passed through the dialyzer 204 and flows through the inlet blood line 208. The blood then passes through the valve 100 to the arterial blood line 212. The blood re-enters the artery of the patient via the arterial blood line 212. During reversed flow, the pump 202 is operated in the same manner (i.e., the same direction) in which it is operated during normal flow. The pump 202  
30 typically pumps blood at a rate of about 300 ml/min during reversed flow operation. However, other flow rates are possible. The pump 202 can, for example, be configured

to pump the blood at a rate of about 50 ml/min to about 600 ml/min during periods of reversed blood flow.

After the desired period of reversed blood flow is completed, the pump 202 is again stopped and the flow directing element 120 is rotated back into the normal flow  
5 position. The pump 202 is then restarted, and the blood treatment is resumed.

While various embodiments have been described above, other embodiments are possible.

While the flow directing element 120 has been described as being press-fitted within the cavity 105 formed between the first and second valve bodies 102, 104 in  
10 order to create liquid-tight seals between the ends of the flow directing element 120 and the end plates 142, 144 of the first and second valve bodies 102, 104, other sealing techniques can alternatively or additionally be used. In some embodiments, for example, gaskets are attached to each axial end of the flow directing element 120. The gaskets can have a shape that corresponds to the shapes of the end surfaces of the flow  
15 directing element 120. For example, each of the gaskets can include an outer ring-shaped member and a central partition that extends through a central aperture of the ring-shaped member to form two semi-circular flow passages. The gaskets can be attached (e.g., adhesively attached, thermally bonded, chemically bonded, or over-molded) to the ends of the flow directing element 120 such that the fluid passages of  
20 the gaskets align with the flow paths 126A and 126B of the flow directing element 120. The gaskets are compressed between the ends of the flow directing element 120 and the end plates 142, 144 of the first and second valve bodies 102, 104 to form a liquid-tight seal between the ends of the flow directing element 120 and the end plates 142, 144 of the first and second valve bodies 102, 104. The gaskets can include one or more  
25 biocompatible materials that have a durometer of about 30 Shore D to about 40 Shore D (e.g., about 30 Shore D). Examples of materials from which the gaskets can be formed include polyisoprene latex, silicone, krayton, and blends of these types of materials.

In some implementations, the flow directing element (e.g., the cylindrical outer  
30 wall 122 and/or the partition 124) and/or the first valve body 102 and the second valve body 104 can include a fluid sealing element (e.g., an O-ring style sealing wiper, or

other sealing elements) disposed along its edges to limit fluid from inadvertently flowing from the first and second flow paths.

In some implementations, one of the valve bodies includes a recessed slot portion that substantially defines the entire slot and the opposite valve body does not include a slot portion. Alternatively or additionally, the flow directing element can include other types of projections that allow the flow directing element to be moved within the blood flow reversal valve. For example, in some implementations, the flow directing element includes a region having teeth exposed within the slot that matingly engage teeth of a gear that is external to the blood flow reversal valve.

While the blood flow reversal valve state indicators 123, 125 have been described as being in the form of words applied to the first valve body, other types of indicators can be used for indicating the state of the blood flow reversal drive. For example, in some implementations, colored figures or suggestive symbols can be applied to indicate the state of the blood flow reversal valve. The indicators can alternatively or additionally be applied to other components of the blood flow reversal valve. For example, the indicators can be applied to the second valve body, or the indicators can be applied to portions of the flow directing element that become visible within slot when the flow directing element is rotated to the position associated with the particular indicator.

While the flow directing element 120 has generally been described as having a cylindrical cavity divided into two substantially half-circle shaped helical flow paths by the generally helical partition 124, other configurations are possible. Figure 9, for example, is an exploded, perspective view of an alternative blood flow reversal valve 300 having a flow directing element 320 that includes two helical flow paths 322, 324. Each of the flow paths 322, 324 has a substantially curved cross-sectional shape (e.g., a kidney shaped cross-sectional area) that follows a substantially helical path through the flow directing element 320. The flow directing element 320 is disposed in the cavity 105 between the first and second valve bodies 102, 104 and is rotatable between a normal flow position and a reverse flow position to fluidly connect different fluid end plate passages 106, 108, 110, 112. The flow directing element 320 can be sealed within the cavity 105 using any of the various techniques described above with respect to the flow directing element 120.

The curved flow paths 322, 324 can improve fluid flow through the blood flow reversal valve 300, as well as reduce blood coagulation. The geometry and arrangement of the curved flow paths 322, 324 can also affect the angular distance that the flow directing element 320 needs to be rotated in order to reverse the flow through the blood flow reversal valve. The rotation angle by which the flow directing element 320 must be rotated to reverse the flow through the valve 300 depends on several factors including the axial length and twist angle of the flow paths 322, 324. The required rotation angle can typically be determined by subtracting the twist angle of the flow path from 180 degrees. Therefore, as the twist angle increases (and the span and size of the flow path 322 increases), the rotation angle needed to reverse the flow decreases. The flow paths 322, 324 are typically designed such that rotating the flow directing element 320 by about 5 degrees to about 180 degrees (e.g., about 60 degrees to about 120 degrees, about 90 degrees) about the longitudinal axis of the valve 300 is sufficient to reverse flow through the valve 300.

Figures 10 and 11 are cutaway perspective views that illustrate the different positions of the flow directing element 320 relative to the first and second valve bodies 102, 104. Referring to Figure 10, when the flow directing element 320 is arranged in a first position (e.g., the normal flow position) relative to the first and second valve bodies 102, 104, the first flow path 322 fluidly connects the axially aligned fluid passages 106 and 110 and the second flow path 324 fluidly connects the axially aligned fluid passages 108 and 112. Referring to Figure 11, when the flow directing element 320 is arranged in a second position (e.g., the reversed flow position) relative to the first and second valve bodies 102, 104, the first flow path 322 fluidly connects the axially misaligned fluid passages 108 and 110 and the second flow path 324 fluidly connects the axially misaligned fluid passages 106 and 112 to reverse the blood flow through the valve 300.

The valve 300 can be incorporated into a blood line set and connected to the hemodialysis machine 201 in the manner described above with respect to the valve 100. Thus, the actuator 254 can be used to automatically reverse blood flow through the valve 100 during treatment.

While the blood flow reversal valves 100, 330 include mating tabs and slots that are used to secure the valve bodies 102, 104 to one another, other devices or techniques

can be used. For example, alternatively or in addition to interlocking tabs and slots, fasteners (e.g., threaded fasteners (e.g., bolts or screws), rivets, or other fasteners) can be used. In some implementations, one of the valve bodies includes a circumferentially formed recess or lip that is sized to receive and be engaged by a circumferentially formed resilient conical ring disposed around an adjoining edge of the other valve body. Using the circumferentially formed recess and ring, the two valve bodies can be pressed together and the ring can snap into the recess to secure the valve bodies together. In some implementations, the first and second valve bodies 102, 104 include threaded portions that permit them to be screwed to one another. In some implementations, separate devices, such as clamps can be used to press the first valve body 102 onto the second valve body 104.

While the actuator 254 of the hemodialysis machine 201 has been described as being rotatable, the actuator can alternatively include a vertically moveable element having a hole to receive the pin of the blood flow reversal valve. Alternatively or additionally, the valve retention element can include a moving gear configured to engage a mating gear mounted on the blood flow reversal valve to move the flow directing element.

While the blood lines have been described as being bonded to the blood line connectors using an adhesive, other techniques can be used. For example, the blood lines can be thermally bonded and/or chemically bonded to the blood line connectors. As another example, the blood lines and blood line connectors can include mating luer locking mechanisms that can be used to secure the blood lines to the blood line connectors.

While the blood flow reversal valve has been described as being used in combination with a dialysis machine that is able to automatically reverse the blood flow through the valve when desired, other configurations are possible. For example, in some implementations, a user (e.g., a clinician, patient, or other person administering a blood treatment process) manually moves the flow directing element (e.g., by grasping the projection extending radially from the flow directing element) from the normal flow position to the reversed flow position.

While the blood flow reversal valve has been described as a component for a hemodialysis system, the blood flow reversal valve can alternatively or additionally be

used with other types of blood treatment systems where flow reversal is desired. Examples of other types of blood treatment systems include plasmapheresis, autotransfusion devices, and hemoabsorptive devices.

A number of embodiments have been described. Nevertheless, it will be  
5 understood that various modifications may be made without departing from the spirit and scope of the invention. Accordingly, other embodiments are within the scope of the following claims.

CLAIMS:

1. A blood flow reversal valve comprising:

a first member having a first passage and a second passage;

a second member having a first passage and a second passage, the first and second  
5 members being rotatably fixed relative to one another such that the first passage of the first member is aligned with the first passage of the second member and the second passage of the first member is aligned with the second passage of the second member; and

a flow directing element disposed in a cavity formed between the first and second  
members, the flow directing element comprising a planar member extending through a semi-  
10 helical path in the cavity from a first end of the cavity to a second end of the cavity, the flow directing element being moveable relative to the first and second members between a first position in which the first passage of the first member and the first passage of the second member are fluidly connected and the second passage of the first member and the second  
15 passage of the second member are fluidly connected, and a second position in which the first passage of the first member and the second passage of the second member are fluidly connected and the second passage of the first member and the first passage of the second member are fluidly connected

wherein the first and second members of the blood flow reversal valve are configured  
to remain rotatably fixed with respect to one another while the flow directing element moves  
20 from the first position to the second position.

2. The blood flow reversal valve of claim 1, wherein the flow directing element is rotatable about a longitudinal axis of the blood flow reversal valve.

3. The blood flow reversal valve of claim 2, wherein the first passages are aligned  
along an axis that is substantially parallel to the longitudinal axis, and the second passages are  
25 aligned along an axis that is substantially parallel to the longitudinal axis.

4. The blood flow reversal valve of any one of claims 1 to 3, wherein the flow directing element defines a first flow path and a second flow path.

5 5. The blood flow reversal valve of claim 4, wherein tire first flow path fluidly connects the first passage of the first member to the first passage of the second member and the second flow path fluidly connects the second passage of the first member to the second passage of the second member when the flow directing element is in the first position.

6. The blood flow reversal valve of claim 5, wherein the first flow path fluidly connects the second passage of the first member to the first passage of the second member and the second flow path fluidly connects the first passage of the first member to the second passage of the second member when the flow directing element is in the second position.

7. The blood flow reversal valve of any one of claims 4 to 6, wherein the flow directing element is substantially cylindrical.

8. The blood flow reversal valve of any one of claims 4 to 6, wherein the first and second flow paths are semi-helical.

15 9. The blood flow reversal valve of claim 8, wherein each of the first and second flow paths has a kidney-shaped cross-sectional area.

10. The blood flow reversal valve of any one of claims 4 to 6, wherein each of the first and second flow paths has a substantially half-circular cross-sectional area.

20 11. The blood flow reversal valve of any one of claims 1 to 10, wherein the partition twists by about 5 degrees to about 180 degrees from a first end of the body to a second end of the body.

12. The blood flow reversal valve of claim 11, wherein the partition twists by about 90 degrees from the first end of the body to the second end of the body.

25 13. The blood flow reversal valve of any one of claims 1 to 12, further comprising a projection that extends radially from the flow directing element.

14. The blood flow reversal valve of claim 13, wherein the projection extends through a slot that is defined by at least one of the first and second members.

15. The blood flow reversal valve of claim 14, wherein the first and second members cooperate to define the slot.

5           16. The blood flow reversal valve of claim 15, wherein the slot extends circumferentially about the first and second members.

17. The blood flow reversal valve of any one of claims 14 to 16, wherein the projection extends radially a sufficient distance to engage an actuator of a blood treatment machine when the blood flow reversal valve is connected to the blood treatment machine.

10           18. A blood treatment system comprising:

a blood flow reversal valve comprising

a first member having a first passage and a second passage;

a second member having a first passage and a second passage, the first and second members being rotatably fixed relative to one another such that the first passage of the first member is aligned with the first passage of the second member and the second passage of the first member is aligned with the second passage of the second member; and

a flow directing element disposed in a cavity formed between the first and second members, the flow directing element comprising a planar member extending through a semi-helical path in the cavity from a first end of the cavity to a second end of the cavity, the flow directing element being moveable relative to the first and second members between a first position in which the first passage of the first member and the first passage of the second member are fluidly connected and the second passage of the first member and the second passage of the second member are fluidly connected, and a second position in which the first passage of the first member and the second passage of the second member are fluidly connected and the second passage of the first member and the first passage of the second member are fluidly connected; and

a blood treatment device comprising:

a valve retention element configured to secure the blood flow reversal valve to the blood treatment device; and

an actuator configured to move the flow directing element of the blood flow reversal valve from the first position to the second position,

wherein the first and second members of the blood flow reversal valve are configured to remain rotatably fixed with respect to one another while the flow directing element moves from the first position to the second position.

19. The blood treatment system of claim 18, wherein the valve retention element comprises resilient fingers configured to releasably engage fluid line connectors of the blood flow reversal valve.

20. The blood treatment system of claim 18 or 19, wherein the actuator defines an opening configured to receive a projection that extends radially from the flow directing element of the blood flow reversal valve.

21. The blood treatment system of claim 20, wherein the actuator is configured to rotate the flow directing element.

22. The blood treatment system of any one of claims 18 to 21, further comprising a controller programmed to move the actuator.

23. The blood treatment system of claim 22, wherein the controller is programmed to move the actuator at a predetermined time during a blood treatment.

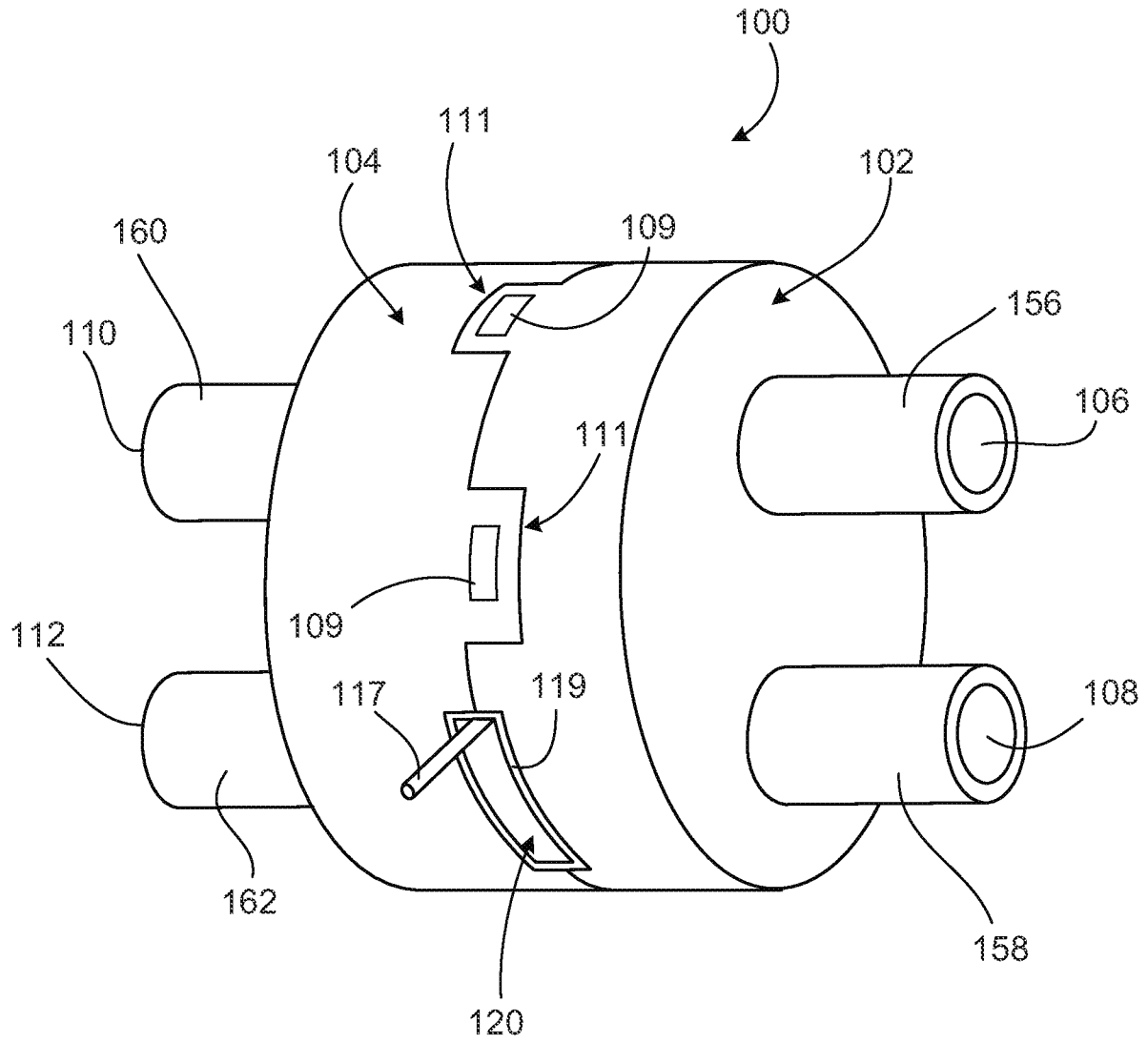
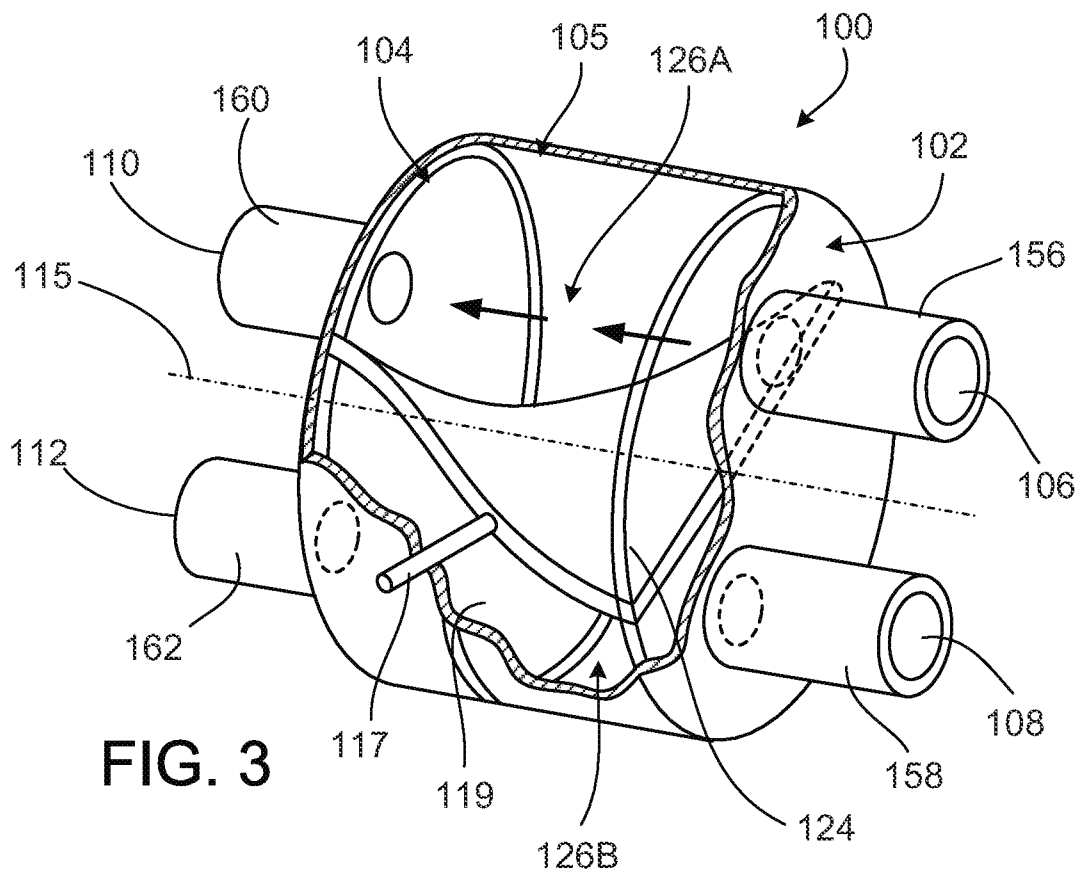
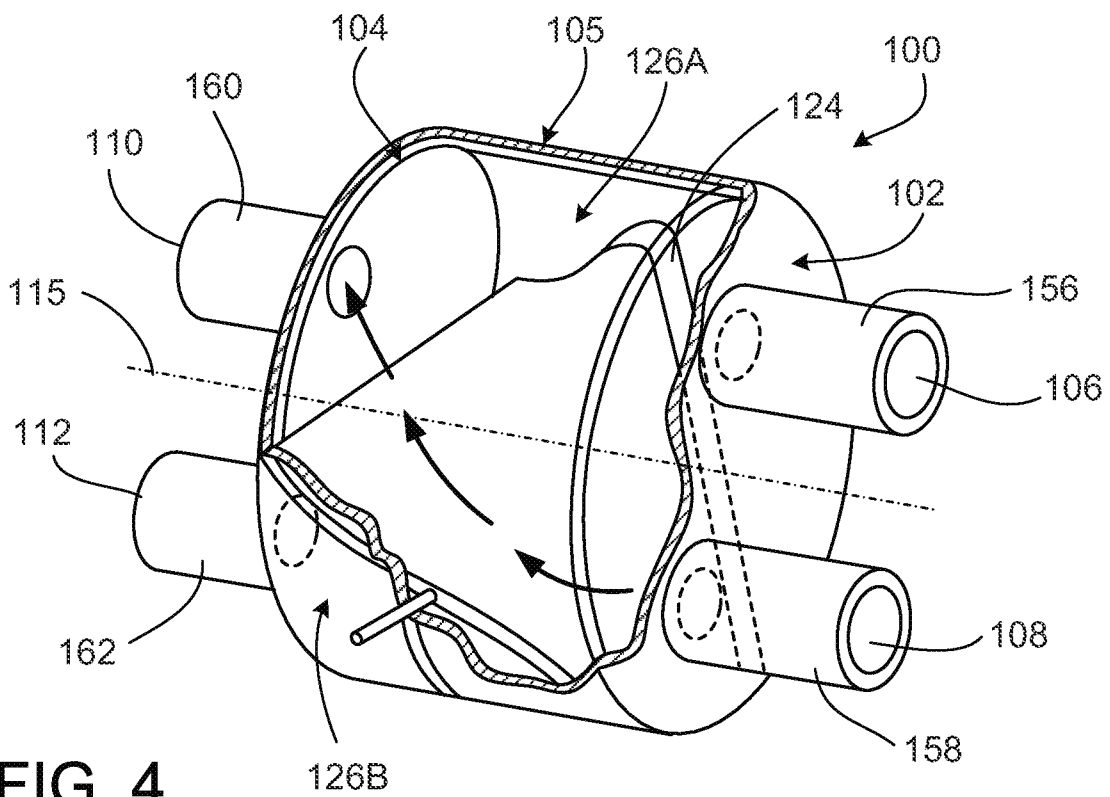

FIG. 1





**FIG. 3**



**FIG. 4**

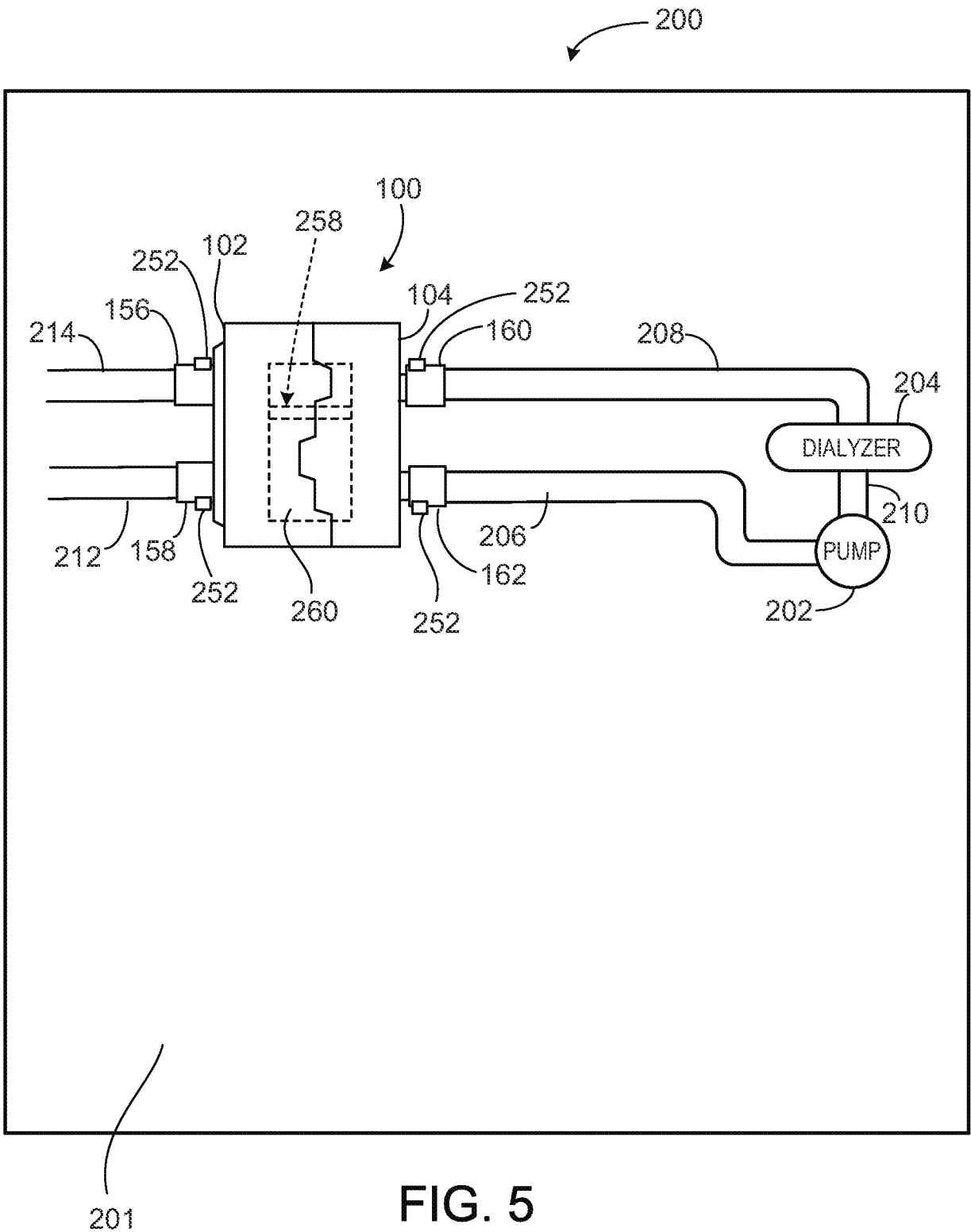

FIG. 5

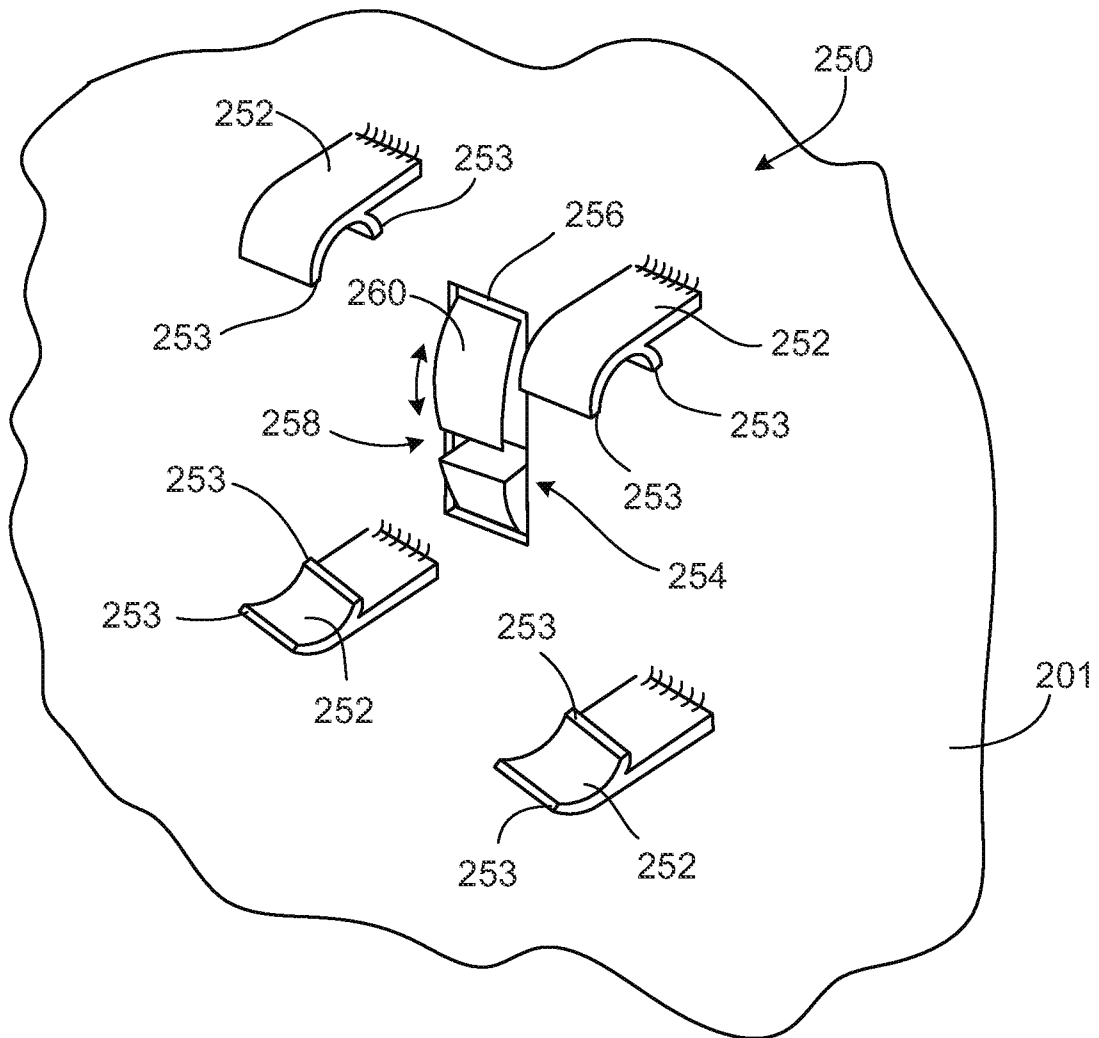

FIG. 6

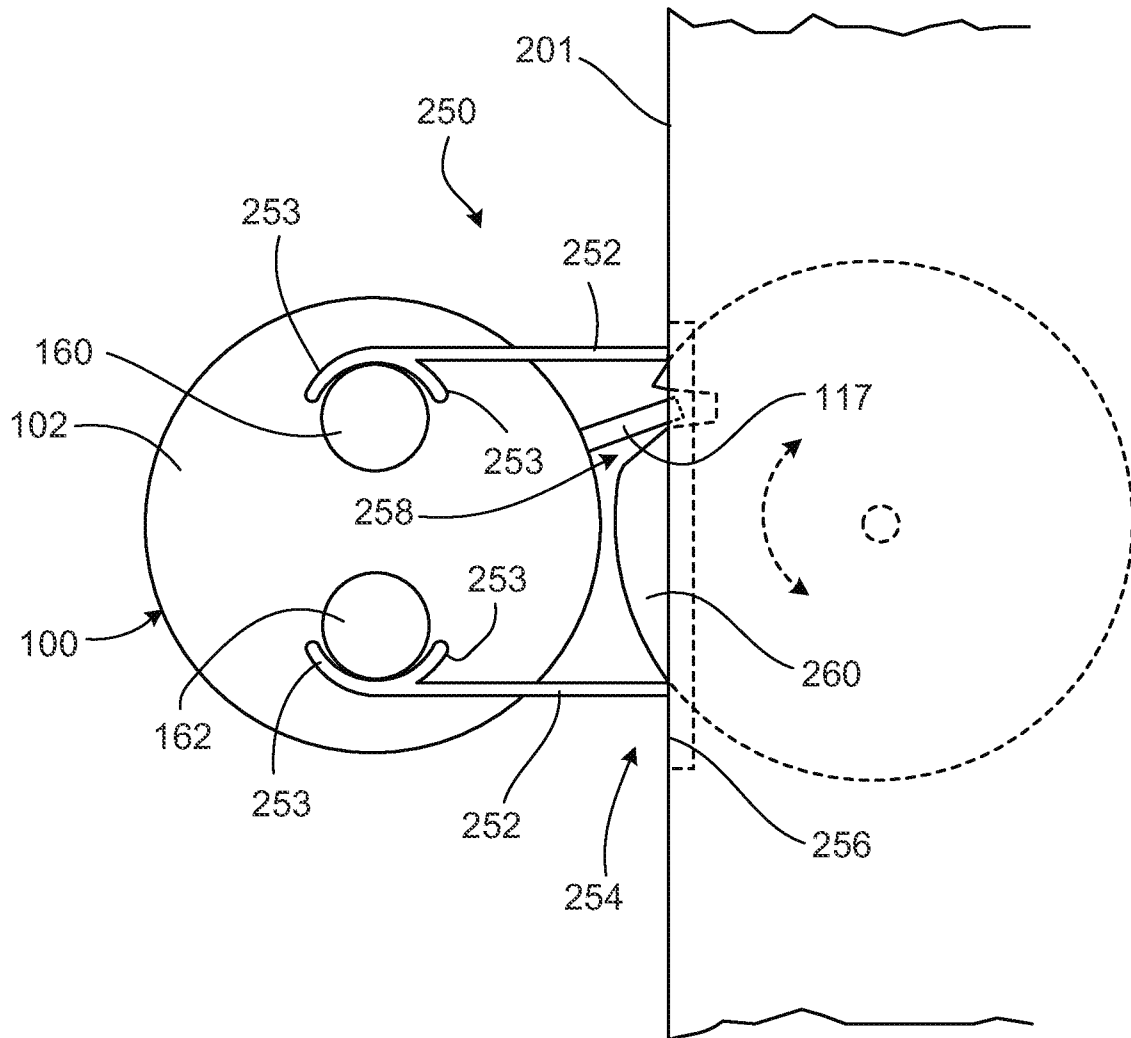

FIG. 7

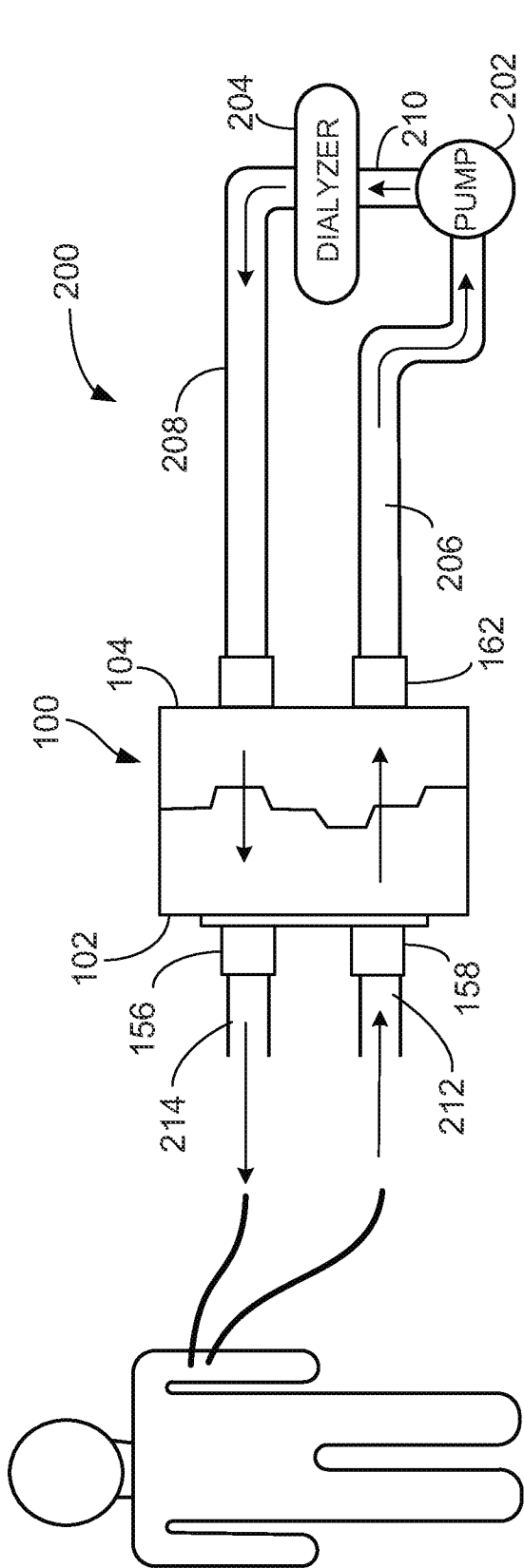

FIG. 8A

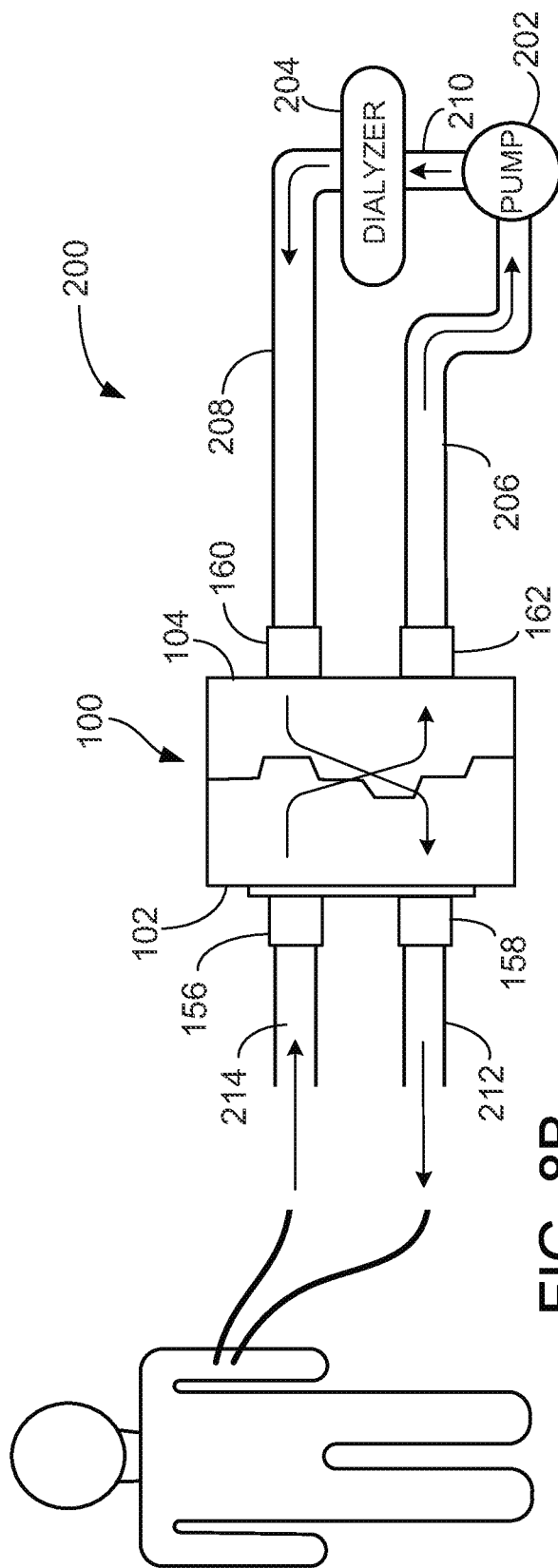

FIG. 8B

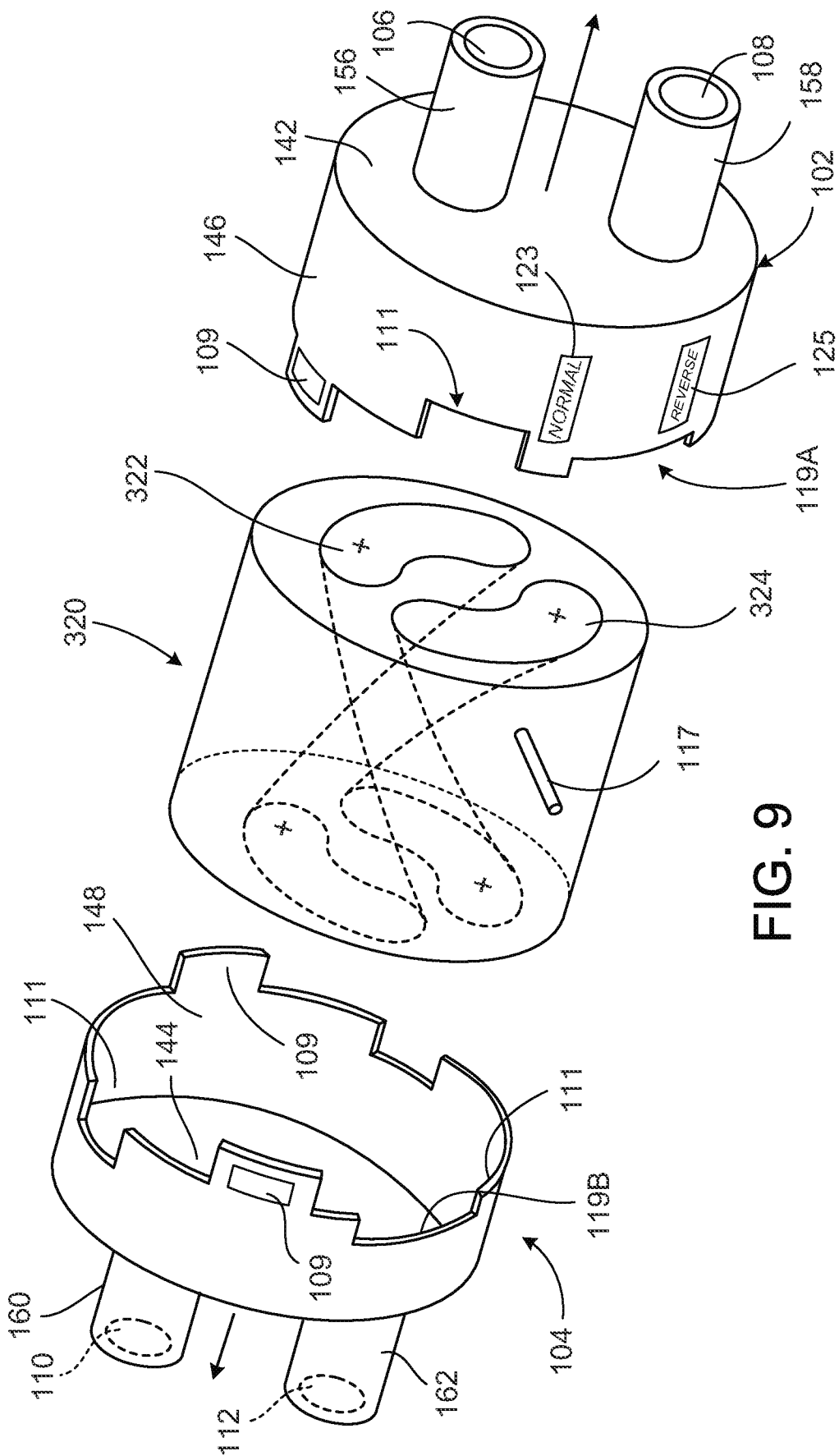

FIG. 9

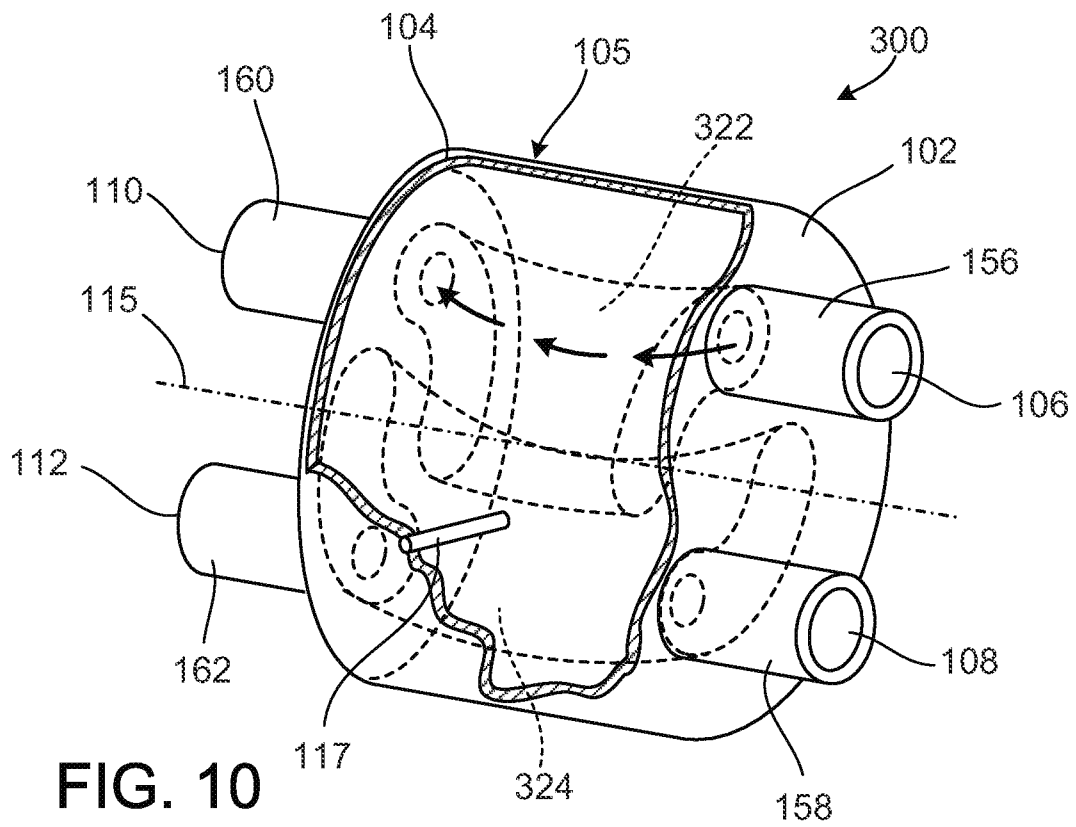

FIG. 10

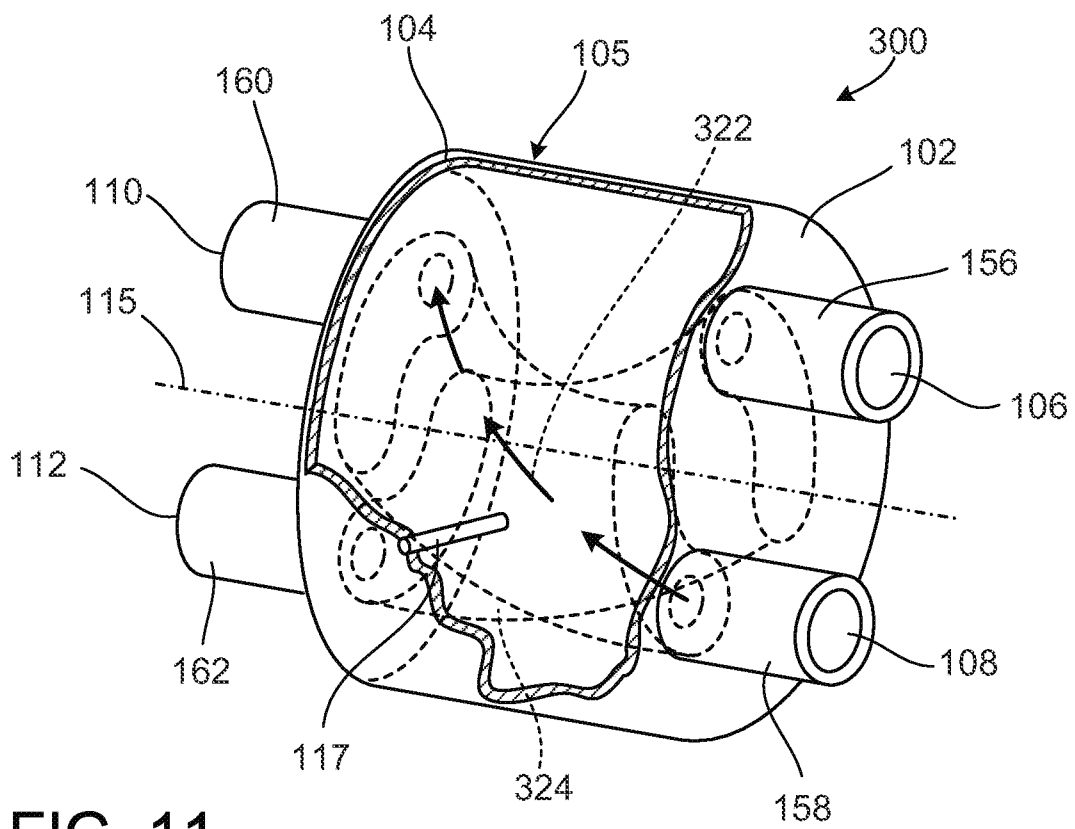

FIG. 11

