

P. BOLLER.
UPHOLSTERY APPARATUS.
APPLICATION FILED JULY 8, 1905.

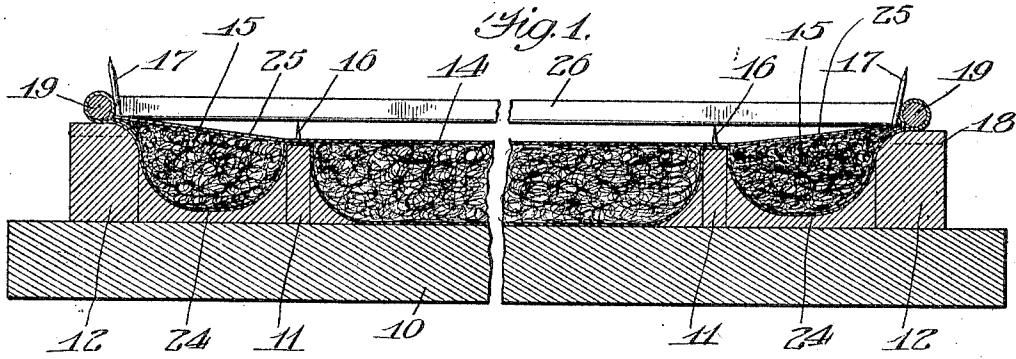
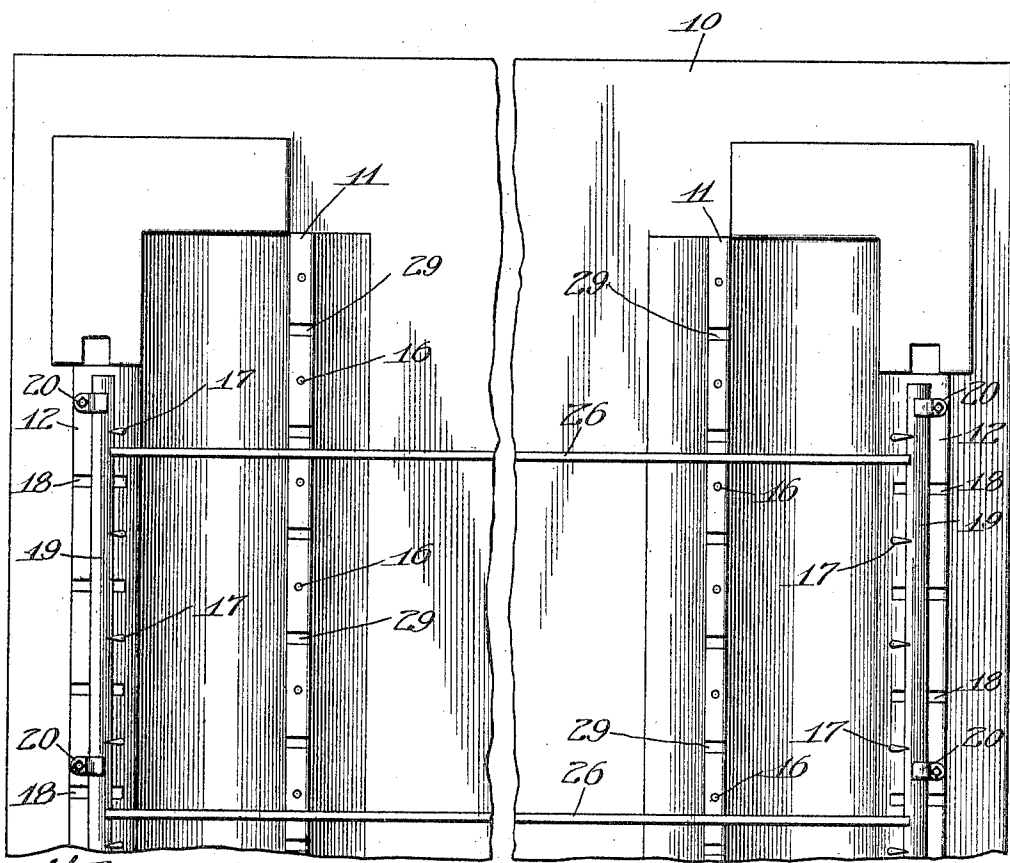

Fig. 2



Witnesses:
Edw. Perry
Robert A. Blair

Inventor:
Peter Boller
 By *Coburn M. Roberts*
his Atty

No. 811,366.

PATENTED JAN. 30, 1906.

P. BOLLER.
UPHOLSTERY APPARATUS.
APPLICATION FILED JULY 8, 1905.

2 SHEETS—SHEET 2.

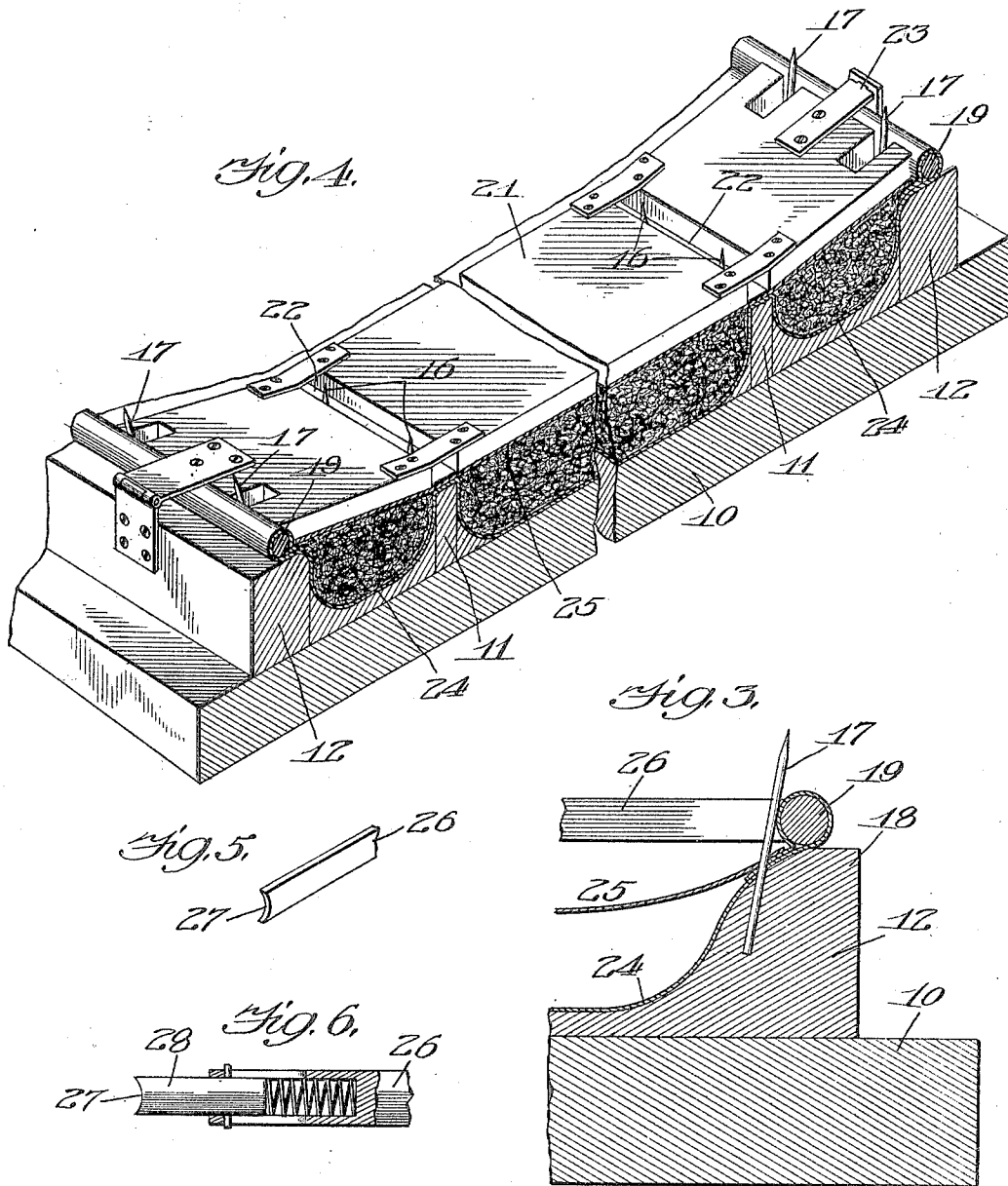

Witnesses:
Ed. D. Perry
Robert N. Weir

Inventor:
Peter Boller;
By Coburn & McRoberts
his Attys

UNITED STATES PATENT OFFICE.

PETER BOLLER, OF CHICAGO, ILLINOIS.

UPHOLSTERY APPARATUS.

No. 811,366.

Specification of Letters Patent.

Patented Jan. 30, 1906.

Application filed July 8, 1905. Serial No. 268,799.

To all whom it may concern:

Be it known that I, PETER BOLLER, a citizen of the United States, residing at Chicago, in the county of Cook and State of Illinois, have invented certain new and useful Improvements in Upholstery Apparatus, of which the following is a specification, reference being had therein to the accompanying drawings.

This invention relates to an improved apparatus for making roll-edge cushions or pads for use in upholstering furniture, such as couches; and the object of the invention is to provide a simple and efficient apparatus for this purpose having certain features of novelty, which will be hereinafter fully described and then more particularly pointed out in the appended claims.

In the accompanying drawings, illustrating embodiments of the several features of my invention, Figure 1 is a sectional view of a mold or form exemplifying certain features of my invention. Fig. 2 is a plan view of a portion of the mold or form shown in Fig. 1. Fig. 3 is a sectional view upon an enlarged scale. Fig. 4 is a perspective view of a mold provided with a sectional follow-board, and Figs. 5 and 6 are detail views showing forms of cross braces or stays which may be employed.

The mold or form here illustrated is designed for making pads or covers provided with what is known in the art as "roll edges," and for that purpose it consists of a suitable base 10, provided at each side with a pair of parallel rails 11 and 12. The inner rails 11 are spaced a suitable distance apart to form a central channel 14 to receive the material forming the body of the pad and with the outer pair of parallel rails 12 form lateral or side channels 15, in which the roll edges are formed. The side channels are relatively narrow in comparison with the width of the central channel, as clearly shown in Fig. 1.

The rails 11 are provided with suitable pins 16, and the rails 12 are provided with relatively long pins 17, which latter are preferably inclined or bent outwardly, as shown in the drawings. The rails 12 are also provided with passages or grooves 18 for a purpose hereinafter described.

Rods 19, which form a part of the finished pad, are adapted to lie along the outer faces of the pins 17 upon the outer rail 12. The purpose of bending or inclining the pins 17 outwardly is to provide against the accidental

displacement of the rods 19 during the operation of forming a cushion or pad, as hereinafter described, although, if desired, any other suitable retaining device, such as turn-buttons or clamps 20, may be provided for this purpose.

The mold or form is provided with a divided follow-board 21, the sections of which are suitably hinged to one of the outer rails 12 beyond the pins 17, so as to clear the rod 19 on such rail. Each section of the follow-board is provided with openings or passages 22, adapted to register with and receive the pins 16 and 17 when the sections of the follow-board are utilized to compress the material of the pad or cushion. The sections of the follow-board may be held in closed position by means of any suitable catches, such as those shown at 23. The construction of the follow-board sections is clearly shown in Fig. 4, where one of the sections is shown in detail.

In the use of the device the material 24, adapted to form the top or cover of the pad or cushion, is placed face downward in position in the mold, as shown in Fig. 1, being held thereon by the pins 16 and 17. One of the rods 19 is then placed in position against the pins 17 of each outer pin-rail, and the edge or margin of the cover is then folded around the rods and passed back over the pins 17, as shown in Figs. 1, 3, and 4. The filling material is then placed upon the cover in the central and lateral channels, and a backing 25, preferably of burlap or other strong fabric, is then laid over the stuffing material, and the sections of the follow-board are placed in operative position to compress and compact the filling material, which is shown in Fig. 4. After the follow-board has performed its work the sections are released and removed out of the way in order that suitable cross-braces or stays 26 may be placed transversely between the rods 19 in order to hold the pad or cushion in form until it is secured upon the base or frame of a suitable couch or other article to be upholstered. These cross-braces or stays may be in any suitable form and preferably are flexible in order to be easily removed when the pad is being secured on its frame. For convenience of connecting the parts the ends of the cross-braces or stays may be provided with recesses or seats 27, adapted to receive the rods 19. Before or after the cross-braces or stays have been secured in place the ends of the cover and backing are sewed together, and in order to

facilitate this operation the rails 12 are provided with the grooves 18 for the passage of the needle. The rods 19 form a part of the completed pad or cushion, and after the ends of the cover and backing have been sewed together the pad or cushion is removed from the form or mold and secured upon the base or frame of its associated article of furniture, the cross-braces or stays 26 holding the pad or cushion in its extended position, and thereby relieving the operator from the necessity of manually stretching it as he tacks it in place, these cross-braces or stays being removed one by one as the operator carries forward the fastening of the pad in place upon the form. The connection of the cross-braces or stays with the rods 19 is so slight as to permit them to be readily and easily removed by merely bending or springing them slightly, so as to withdraw their ends from contact with the rods, or by springing one of the rods 19 slightly in an outward direction. It is obvious that the form of these cross-braces or stays may be varied without departing from the spirit of my invention in this respect. For example, as shown in Fig. 6, the same result may be obtained in substantially the same manner by means of a rigid cross-brace provided with a flexible section 28.

In the use of the device under normal conditions the rods 19 will be securely held in place against accidental dislodgment by reason of their seating under the inclined pins 17. However, if for any reason it is desired to provide additional retaining means, or if it is desired to make the pins 17 vertical, suitable clamps or turn-buttons 20 may be provided for the rods.

The sections of the follow-board may be hinged or otherwise secured to the mold, or they may be merely loose sections adapted to be clamped in position by any suitable means, the only requisite being that they shall not interfere with the pins.

The inner rails 11 may also be grooved, as at 29, in order to allow the cover and backing to be sewed at such points, if desired.

Having described my invention, what I claim is—

1. In a device for manufacturing roll-edge

upholstery, a form or mold having rails providing central and lateral channels, parallel rows of pins on the rails, and a divided follow-board each section of which is hinged to one of the outer rails so as to clear the rod located in the edge roll and provided with openings or passages adapted to receive the pins.

2. In an apparatus for manufacturing roll-edge upholstery, a form having rails providing central and parallel side channels, pins on the rails, and a divided follow-board each section of which is hinged to an outer rail beyond the pins thereon and provided with openings or passages in alignment with the rails when the parts are assembled.

3. In an apparatus for manufacturing roll-edge upholstery, a form having central and lateral parallel channels, inclined pins outside of the lateral channels and adapted to retain parallel rods along their outer faces.

4. In a device for manufacturing roll-edge upholstery, a form having parallel rails providing central and lateral channels, pins on the outer rails, and flexible stays or cross-braces adapted to extend between the rods on the outer rails outside of the pins thereof.

5. In an apparatus for manufacturing roll-edge upholstery, a form having pin-rails providing central and lateral channels, and flexible stays or cross-braces having seats at their ends adapted to receive rods located on the outer rails outside of the pins thereof.

6. In an apparatus for manufacturing roll-edge upholstery, a form having rails providing central and lateral channels, and stays or cross-braces adapted to brace rods located in the edge rolls and to be removed therefrom by bending one of the coacting parts.

7. In a device for manufacturing roll-edge upholstery, a form having rails providing central and lateral channels, the outer rails having pins and being grooved for the passage of a needle through the upholstery attached to such rails by the pins.

In testimony whereof I affix my signature in presence of two witnesses.

PETER BOLLER.

Witnesses:

ELIZABETH MOLITOR,
J. McROBERTS.