



(11) (21) (C) **2,110,824**  
(22) 1993/12/06  
(43) 1995/06/07  
(45) 2001/02/27

(72) Feist, Patrick, CA

(73) FEIST, KENNETH FRANK, CA

(51) Int.Cl.<sup>5</sup> E06B 9/08

(54) **RIDEAU DE DOUCHE, ESCAMOTABLE**

(54) **RETRACTABLE SHOWER SCREEN**

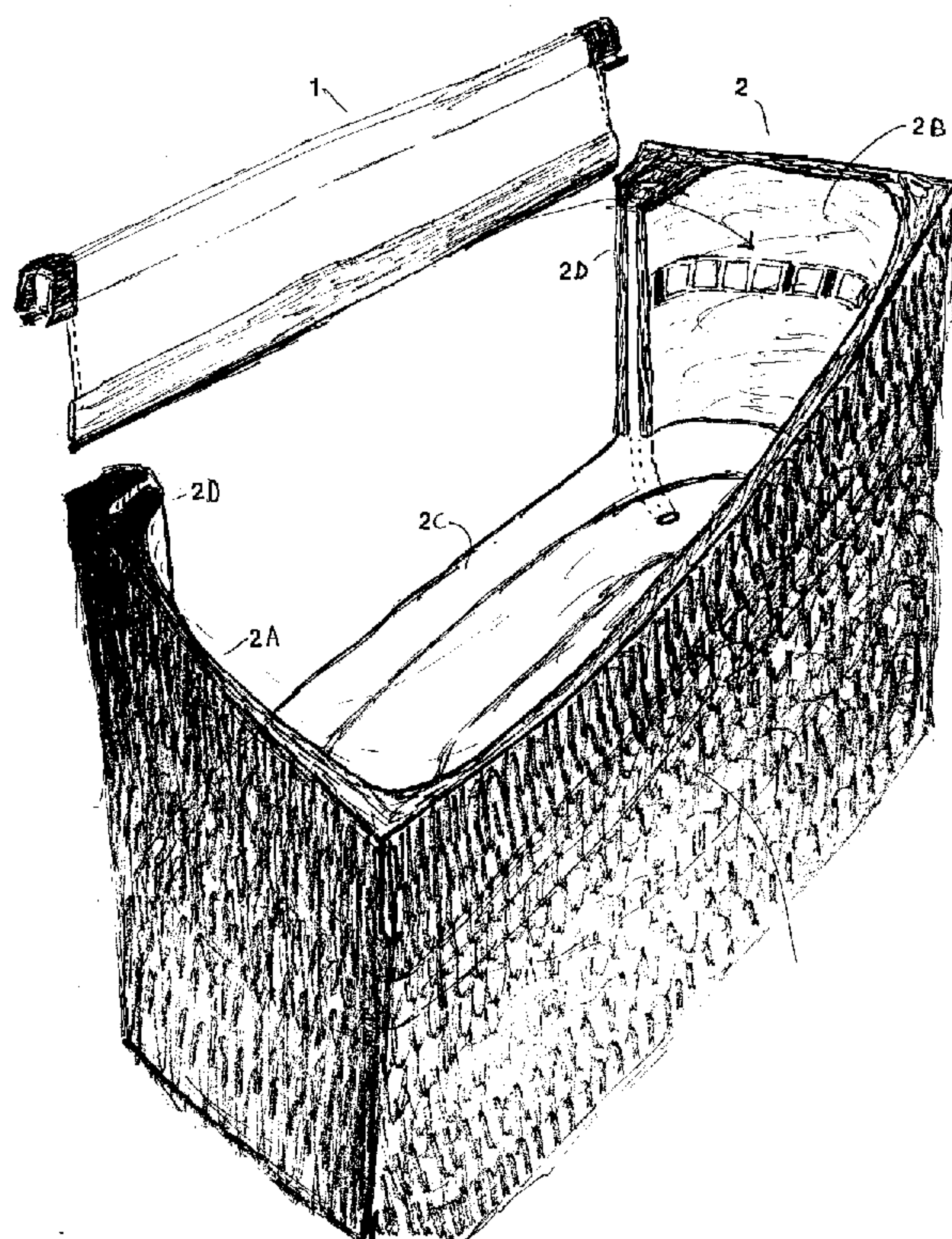

(57) A retractable shower screen has a spring-biased roller with first and second ends; first and second brackets, mountable to opposed walls in a shower stall, for releasable respective mating engagement with the first and second ends of the roller; a first flexible sheet having first and second longitudinal edges, the first longitudinal edge of the first flexible sheet releasably attachable to the roller between the first and second ends; a second flexible sheet having first and second longitudinal edges, the first longitudinal edge of the second flexible sheet releasably attachable to the second longitudinal edge of the first flexible sheet; sealing means, releasably attachable to the second longitudinal edge of the second flexible sheet, for sealing the second longitudinal edge of the second flexible sheet to the shower stall; the spring-biased roller having spring biasing means for rotating the roller, whereby the first and second flexible sheets may be consecutively rolled onto and unrolled from the roller; a ratchet co-operating with the roller, the ratchet releasably engageable whereby when engaged the flexible sheets may only be unrolled from the roller, the engaged ratchet preventing retraction of the flexible sheets onto the roller; whereby when the ratchet is engaged the second flexible sheet may be unrolled from the roller so as to extend from the housing the first longitudinal edge of the second flexible sheet and the second longitudinal edge of the first flexible sheet, the second flexible sheet then detachable from the first flexible sheet.



2110824

**RETRACTABLE SHOWER SCREEN**

**Abstract of the Disclosure**

A retractable shower screen has a spring-biased roller with first and second ends; first and second brackets, mountable to opposed walls in a shower stall, for releasable respective mating engagement with the first and second ends of the roller; a first flexible sheet having first and second longitudinal edges, the first longitudinal edge of the first flexible sheet releasably attachable to the roller between the first and second ends; a second flexible sheet having first and second longitudinal edges, the first longitudinal edge of the second flexible sheet releasably attachable to the second longitudinal edge of the first flexible sheet; sealing means, releasably attachable to the second longitudinal edge of the second flexible sheet, for sealing the second longitudinal edge of the second flexible sheet to the shower stall; the spring-biased roller having spring biasing means for rotating the roller, whereby the first and second flexible sheets may be consecutively rolled onto and unrolled from the roller; a ratchet co-operating with the roller, the ratchet releasably engageable whereby when engaged the flexible sheets may only be unrolled from the roller, the engaged ratchet preventing retraction of the flexible sheets onto the roller; whereby when the ratchet is engaged the second flexible sheet may be unrolled from the roller so as to extend from the housing the first longitudinal edge of the second flexible sheet and the second longitudinal edge of the first flexible sheet, the second flexible sheet then detachable from the first flexible sheet.

RETRACTABLE SHOWER SCREEN

Field of the Invention

5 The invention relates to the field of retractable shower screens and in particular shower screens of the type comprising a screen retractably mounted on a roller housed in an elongate casing.

Background of the Invention

10 United States Patent No. 4,122,559 which issued October 31, 1978 to David Kelly for "Shower Screen" describes a shower screen unit having a horizontal roller shaft to which an end region of an elongate sheet of material is attached. The roller shaft is supported in a substantially horizontal position above  
15 the edge of a bath, for example, and is rotatable about its' longitudinal axis so that the elongate sheet of material can be rolled up on the roller shaft when not in use, or unrolled from the roller shaft to close off the shower area. Kelly teaches a further element in combination comprising at least one freely  
20 rotatable water-absorbent roller, parallel to the roller shaft, the absorbent roller pressing against the screen material so as to absorb water from the screen material as the screen material is rolled up on the roller shaft. Kelly also discloses that the roller screen operates in an identical manner to a retractable  
25 window blind or alternatively that the roller shaft may be connected to an electric motor to roll up or unroll the screen.

30 This invention relates to shower screen units of which the Kelly device is an example. It is an object of this invention to provide an improvement in the means by which the shower screen material, that is, the elongate sheet, may be attached to the roller shaft and the means for controlling the rolling and unrolling of the screen from the roller shaft.

35 It is a further object of the present invention to provide an improved roller shower screen unit in which the shower

screen material is guided vertically within wall tracks or rails and the shower curtain material has along its' lower-most edge a seal bar for mating with the edge of a bathtub or shower stall basin, the ends of the seal bar releasably engagable with the  
5 base of the wall tracks so as to inhibit the egress of water from the tub or shower stall.

It is a further object of the invention to provide a ratchet mechanism for controlled unrolling of the shower screen  
10 from the roller shaft, so as to facilitate locking the shower screen in the unrolled position so that the screen may be removed from the roller shaft for cleaning.

#### Summary of the Invention

15 The retractable shower screen of the present invention has a spring-biased roller having first and second ends, the ends of the roller fitting into first and second brackets mounted to opposed walls in a shower stall. The roller ends releasably mate  
20 with the first and second bracket. A first sheet of flexible material having first and second longitudinal edges may be provided so that the first longitudinal edge of the first flexible sheet may be releasably attached to the roller between the ends of the roller. A second flexible sheet, the shower  
25 screen, having first and second longitudinal edges, is provided so that the first longitudinal edge of the second flexible sheet may be releasably attached to the second longitudinal edge of the first flexible sheet or directly to the roller if a first flexible sheet is not incorporated. A sealing means is provided,  
30 releasably attachable to the second longitudinal edge of the second flexible sheet, for sealing the second longitudinal edge of the second flexible sheet to the sill of the shower stall basin.

35 The spring-biased roller has conventional spring biasing means for rotating the roller, whereby the first and second flexible

# 2110824

sheets, when attached, may be consecutively rolled onto and unrolled from the roller.

5 A ratchet is provided, mountable between the first bracket and the first end of the roller. The ratchet has a releasably engageable toothed gear and dog mechanism which co-operates with the roller to prevent retraction of the flexible sheets onto the roller when the ratchet is engaged. The ratchet is engaged by pivotally engaging the dog with the toothed gear. When the  
10 ratchet is engaged the second flexible sheet may be unrolled from the roller so as to extend the second flexible sheet from the housing thereby exposing the first longitudinal edge of the second flexible sheet, and also exposing the second longitudinal edge of the first flexible sheet if incorporated, whereby the  
15 second flexible sheet may be detached from the first flexible sheet or from the roller for cleaning.

## Brief Description of the Drawings

20 Figure 1 is, in exploded perspective view, a shower stall and the retractable shower screen of the present invention.

Figure 2 is an exploded perspective partial cut-away view of a preferred embodiment of the retractable shower screen  
25 of the present invention.

Figure 3 is an exploded perspective partial cut-away view of the ratchet mechanism of Figure 2.

30 Figure 4 is a perspective cut-away view along line 4-4 in Figure 3 of our alternative embodiment of the ratchet mechanism of Figure 3.

Figure 5 is an end-on side elevation view of the  
35 assembled retractable shower screen of Figure 2.

# 2110824

Figure 6 is, in perspective view, a ratchet mounting attachment.

5 Figure 7 is a perspective partial cut-away view of an alternative embodiment of the retractable shower screen of the present invention.

10 Figure 8 is, in plan view, a shower screen rail for use in co-operation with the retractable shower screen of the present invention.

Figure 9 is, in plan view, an alternative embodiment of a shower screen rail.

15 Figure 10 is, in plan view, a further alternative embodiment of a shower screen rail.

Figure 11 is, in end-on elevation view, an alternative embodiment of a screen extension.

20 Figure 12 is, in perspective view, an alternative embodiment of a wall mounting attachment.

25 Figure 13 is, in exploded perspective view, an alternative embodiment of a screen fastening means.

## Detailed Description of Preferred Embodiments

30 Figure 1 illustrates how retractable shower screen 1 of the present invention co-operates with a shower stall 2. Shower stall 2 has opposed facing side walls 2A and 2B and a catch basin 2C. The side walls and the catch basin define a front opening which is used for access to the shower enclosure. Retractable shower screen 1 is mounted between side walls 2A and  
35 2B and in the embodiment illustrated in Figure 1 is clipped onto opposed facing moulded rails 2D.

# 2110824

As illustrated in Figure 2, in a preferred embodiment retractable shower screen 1 has spring-biased retractable roller shaft 3 in which, at one end, is fixedly mounted end cap 5. Spring-biased retractable roller shaft 3 may be of a conventional design incorporating at one end (conveniently the end opposed to the end of roller 3 mounted onto end cap 5) a conventional roller-blind spring assembly such as that manufactured by Stewart Hartshorn, a division of Cooper Industries, Sturgis, Michigan, U.S.A. End cap 5 has gear teeth 7 and axle 9 so that when fixedly mounted in roller shaft 3, gear teeth 7 extend radially outward from around the rim of the roller shaft, and axle 9 extends from the roller shaft along the roller shaft longitudinal axis. Ratchet housing 11, illustrated in exploded detail in Figure 3, supports ratchet lever 13 pivotally mounted within housing 11 above end cap receiving cavity 15 (see Figure 3).

As also illustrated in Figure 2, a strip of flexible material, referred to as a first flexible sheet, or alternatively as screen extension 37, is attached to roller shaft 3 along a first longitudinal edge 39 of screen extension 37. The other longitudinal edge of screen extension 37, longitudinal edge 43, is attached to the top edge of shower screen 23. In particular, longitudinal edge 39 of shower screen extension 37 slidably mates in groove 41 (see Figure 5). Groove 41 is a longitudinal groove in roller shaft 3 as best seen in Figure 5. Longitudinal edge 39 fits snugly into groove 41. As may be seen, longitudinal edge 39 may comprise a flexible rod or the like which is attached to longitudinal edge 39 or fitted into a sleeve formed in longitudinal edge 39.

Shower screen extension 37 has lower longitudinal edge 43. Lower edge 43 may be releasably attachable to upper edge 45 of shower screen 23 either by Velcro<sup>TM</sup> or like releasable fasteners, or, in the preferred embodiment illustrated, by means of coupling rails 47. Upper coupling rail 47A is attached to lower edge 43 and, as illustrated in Figure 5, may be attached

## 2110824

by a sliding fitment. That is, lower edge 43 may slidingly mate in an upper groove in upper coupling rail 47A.

5 Corresponding lower coupling rail 47B may similarly be attached to upper screen edge 45 (see Figure 5) so that screen 23 may be releasably attached to screen extension 37 by hooking coupling rails 47 together as depicted in Figure 5.

10 As also illustrated in Figure 2, sponge roller 49 rotates freely about axle 51 journalled in axle mount 53 in ratchet housing 11.

15 Screen 23 has lower edge 55. Seal bar 57 may be slidingly mated onto lower screen edge 55, lower screen edge 55 again being a sliding male fit in upper groove 59 on seal bar 57 (see also Figure 5). In Figure 5, screen 23 is shown in broken outline and is not shown in true relative size. A lower groove 61 on seal bar 57 supports seal 63 in a sliding fit. Seal 63 may be a resilient rubber or like material. Seal bar 57 also  
20 incorporates flanges 57A which act to cascade water away from seal 63 and also provide a handle which may be gripped when lowering seal bar 57 and screen 23. Typically, flanges 57A are notched or otherwise cut-away at the ends of seal bar 57 to enable the ends of seal bar 57 to travel vertically in wall  
25 tracks 95 (see Figure 8).

30 Roller housing 65 may provide an aesthetic cover for roller shaft 3, screen extension 37 and sponge roller 49. Housing 65 may snugly fit over the outside contours of ratchet housing 11 or otherwise attach to ratchet housing 11. Alternatively ratchet housing 11 may snugly fit within housing 65, thus requiring that housing 65 be attachable either directly to the shower stall side walls 2A and 2B, or to side wall mounting brackets such as side wall mounting brackets 67 depicted in  
35 Figure 6. Side wall mounting brackets 67 may be mounted to shower stall side walls 2A and 2B by screws or like fasteners

# 2110824

(not shown) journalled in screw holes 69. Alternatively, as depicted in Figure 12, retractable shower screen 1 may be supported between opposed facing shower stall walls 2A and 2B by spring-biased mounting caps 117. Mounting caps 117 fit over the ends of roller housing 65 and are biased away from the ends of roller housing 65 by spring 119 which act against bearing plate 120 to force mounting caps 117 or at least one mounting cap 117, against a shower stall side wall thereby frictionally holding retractable shower screen 1 in place. End caps 117 may have removable mounting tabs 117A which may be removed from end caps 117 and left permanently affixed either to, or partially behind, wall tracks 95. Tabs 117A mate in a sliding fit with end caps 117.

Within roller housing 65, as depicted in Figure 5, stabilizing brackets 75 may be provided for supporting sponge rollers 49. Brackets 75 are mounted into slots 77.

As illustrated in Figures 3 and 4, ratchet dog 17 is pivotally mounted within housing 11, more specifically within ratchet dog cup 19, so as to be rotatable within cup 19 against the returning spring biasing force of spring 21. End cap axle 9 is journalled in axle mount 25. Ratchet lever 13 is pivoted about pin 27 journalled in pin receiving holes 29A and 29B.

End cap 5, and therefore also roller shaft 3, are free to rotate in the manner of prior art retractable blinds when ratchet lever 13 is rotated so as to disengage dog 17 from teeth 7. Ratchet lever 13 forces dog 17 to rotate within cup 19 forcing gear engaging arm 17A against spring 21 thereby compressing spring 21.

When it is desired to engage the ratchet mechanism to control the unrolling of shower curtain 23 from roller shaft 3, ratchet lever 13 is moved in direction A thereby allowing dog 17 to be forced by spring 21 into engagement with gear teeth 7.

# 2110824

With gear engaging arm 17A engaging gear teeth 7, end cap 5, and thereby roller shaft 3, can only be rotated in direction B, which coincides with rotating roller shaft 3 so as to unroll shower screen 23 from its' rolled up position on roller shaft 3.

5

As illustrated in Figure 3, end cap 5 is held in place within end cap receiving cavity 15 by face plate 31. Face plate 31 has protrusions 33 which friction fit into holes 35 in housing 11 for mounting face plate 31 onto housing 11. Face plate 31 also acts to hold ratchet lever 13, ratchet dog 17, and spring 21 within their respective cavities within housing 11. Roller shaft 3 fits snugly within hole 37 in face plate 31. Roller shaft 3 is a tube which fits onto end cap 5 as end cap 5 protrudes from face plate 31 when face plate 31 is mounted onto housing 11.

15

Figure 4 is a cut away view, along line 4-4 in Figure 3 showing, in addition, an alternative embodiment wherein friction gears 8 are driven off gear teeth 7 on end cap 5. Friction gears 8 rotate about screws 8A which are secured to housing 11. Screws 8A may bear against washers 8B. Screws 8A may be tightened thereby increasing the frictional resistance to the rotation of gears 8. Friction gears 8, with screws 8A tightened, act as a braking mechanism to slow the rotation of end cap 5. Slowing the rotation of end cap 5 regulates the speed with which screen extension 37 and screen 23 is retracted and rolled up onto roller 3.

20

25

A further or alternative friction mechanism for slowing the speed with which shower screen extension 37 and shower screen 23 are retracted onto roller 3 is depicted in Figure 5. Threaded bolt 22 is journalled in housing 65 so that rotating bolt 22 moves resilient ball 22A towards roller 3. When resilient ball 22A is brought into contact with roller 3, the frictional engagement between resilient ball 22A and roller 3 acts as a brake on the rotation of roller 3. Resilient ball 22A could also

35

# 2110824

be a resilient longitudinal roller along the length of roller 3. A further means of frictional braking is to constrain the ends of seal bar 57 snugly within wall tracks 95, the friction between seal bar 57 and wall tracks 95 providing the frictional braking. It is understood that the function of the frictional braking mechanism, whether friction gears 8 or resilient ball 22A, is the controlled protraction of screen 23 onto roller 3 when seal bar 57 is released from engagement with the sill of catch basin 2C.

Illustrated in Figure 6 is a view of the back of ratchet housing 11. Flanges 71 form a sleeve into which slides wall mounting bracket 67, thereby mating flanges 73 snugly under flanges 71. Thus when mounting bracket 67 is mounted to shower stall side wall 2A or 2B, ratchet housing 11 may then be fitted onto mounting bracket 67 when installing retractable shower screen 1.

Seal bar 57 may have other embodiments such as that depicted in Figure 7. As depicted, seal bar 57 has upper flange 79 to which is affixed Velcro™ strip fasteners or like releasable fasteners for detachably fastening lower edge 55 of screen 23 to upper flange 79. Handles 81 are provided, mating in slots 83 in seal bar 57. Handles 81 may be used to lower and guide seal bar 57 when unrolling screen 23. Seal 63 is mounted in sliding fit in channel 61A. Seal bar 57 has protrusions 85 which matingly engage inner scalloped surface 87 on flanges 89. Flanges 89 are mounted to a base so as to form a complete seal bar locking mechanism 91 mountable to the sill of a shower basin or the like.

Seal bar locking mechanism 91 may be mounted, one at each end, in the corner formed between the edge or sill of shower stall catch basin 2C, and the shower stall side walls 2A and 2B. Locking mechanisms 91 hold seal bar 57 firmly engaged against the edge or sill of catch basin 2C so that the egress of water under seal bar 57 is inhibited by seal 63.

## 2110824

A further embodiment, not shown, of seal bar locking mechanism 91 replaces protrusions 85 and mating scalloped surface 87 with a magnetic locking system whereby mating magnets would be respectively mounted, one facing upwards from the base of locking mechanism 91 and the corresponding magnet on seal bar 57 mounted facing downwards adjacent the end of seal 63.

Shower screen 23 has vertical side edges 93. When screen 23 is deployed, that is, unrolled from shaft 3 so as to engage seal 63 with the edge or sill of catch basin 2C, edges 93 may be constrained within wall tracks 95 as depicted in Figure 8 or moulded rails 2D as depicted in Figure 1. Wall tracks 95 may be mounted to shower side walls 2A and 2B by screws 98 or like fasteners extending through base 99 into wall 2A. Wall track 95 may have hinged flange 101 pivotally mounted to base 99, for example by flexible strip 103. Wall track 95 defines a sufficiently large channel so that when mounted vertically on wall 2A or 2B, the ends of seal bar 57 may travel vertically within wall track 95. With screen 23 deployed, wall track 95 provides an aesthetically appealing valance covering edges 93.

When it is desired to remove seal bar 57 from screen 23, for example when it is desired to remove screen 23 for cleaning, hinged flange 101 is rotated about hinge 103 in direction C to facilitate removal.

An alternative embodiment of wall track 95 is illustrated in Figure 9. Base 99A has barbed rails 105. Barbed rails 105 mate in corresponding contoured grooves 107 in wall track flanges 109.

A further alternative embodiment of wall tracks 95 is illustrated in Figure 10. In this embodiment wall track 95 is a unitary piece of extruded U-shaped channel, possibly made of aluminum or plastic. Baffles 97 serve to inhibit the egress of

## 2110824

water around the edges of screen 23 when screen 23 is deployed and vertical side edges 93 are constrained within wall tracks 95.

5 In an alternative embodiment of shower screen extension 37, shower screen extension 37 and upper coupling rail 47A are replaced by flexible strip 37A illustrated in end-on profile in Figure 11. Hook 111 is shaped to mate with lower coupling rail 47B and protrusion 113 is provided on flexible strip 37A to releasably lock the upper edge of lower coupling rail 47B into  
10 engagement with hook 111. Flexible strip 37A has bulbous top edge 115 for a sliding snug fit in longitudinal roller groove 41.

It is understood that other means of releasably coupling screen extension 37 to screen 23 may be employed. For  
15 example, as illustrated in Figure 13, shower screen extension 37 may be a flexible strip having a long edge 43 and a channel 119. Channel 19 may be formed as part of screen extension 37. Rigid clips 121, which may be made of PVC and the like, mate snugly in channel 119. In particular, rigid channel 123 snaps into  
20 flexible channel 119 and are held firmly in place.

Pegs 125 releasably secure edge 45 of screen 23 against the clips 121 mounted to screen extension 37 by a snug fit of peg ends 127 through openings 129 in screen 23 into mating engagement  
25 with rigid channels 123. Alternatively, instead of screen 23 having openings 129, peg ends 127 may be used to force a bite of screen 23 into channel 123 to thereby releasably fasten screen 23 to screen extension 37. A similar releasable fastening system may be used to releasably fasten edge 55 of screen 23 to seal bar  
30 57.

Seal bar 57 as depicted in Figure 13 has grooves 131 into which may be mounted handles 57A.

35 Also as illustrated in Figure 13, screen 23 may have seams 133 formed along one or both side edges 93. Seams may be by way of

# 2110824

stitching, gluing or heat sealing if screen 23 is made of vinyl or the like. Screen 23 may thus be trimmed to fit different sized shower stalls 2 by cutting along seams 133.

5           As will be apparent to those skilled in the art in the light of the foregoing disclosure, many alterations and modifications are possible in the practice of this invention without departing from the spirit or scope thereof. Accordingly, the scope of the invention is to be construed in accordance with the  
10 substance defined by the following claims.

## WHAT IS CLAIMED IS:

5 1. A roller mountable shower screen comprising:

an elongated spring-biased roller having first and second ends;

10 said roller having a biasing spring for spring assisted rotationally resilient rotation of said roller in a first rotational direction whereby said screen may be rolled onto said roller, said biasing spring adapted to allow reversed rotation of said roller in a second rotational direction opposed to said first rotational direction against a return resilient rotational biasing force of said biasing spring whereby said screen may be unrolled from said roller;

15 said shower screen detachably mountable to said roller along a first edge of said shower screen;

20 releasable ratcheting means co-operating with said first end of said roller for unidirectional unrolling in said second rotational direction of said shower screen from said roller in a first direction when said ratcheting means is engaged in ratcheting engagement with said roller whereby said shower screen is prevented from rolling back onto said roller;

25 said second end of said roller mountable in a support mountable to a shower stall surface for rotatably supporting said second end of said roller;

said ratcheting means further comprising ratchet releasing means for selectively disengaging said ratcheting means from said ratcheting engagement with said roller.

2. The device of claim 1 wherein said first edge of said shower screen is detachably mountable along substantially the length of said roller,

5 said ratcheting means comprising a ratchet gear affixed to said first end of said roller and co-operating with a resiliently-biased mating dog.

3. The device of claim 2 wherein said sealing means comprises a bar having first and second longitudinal edges, said first longitudinal edge of said bar releasably attachable to a second edge of said shower screen opposed to said first edge, said second edge releasably  
10 attachable to a seal, wherein said seal comprises a strip of resilient material.

4. The device of claim 3 wherein said bar further comprises a longitudinal handle, said longitudinal handle comprising a flange extending outwardly from said bar whereby said flange may be grasped to lower in said first direction said shower screen from said roller.

5. The device of claim 4 wherein said ratcheting means is mountable between said first bracket and said first end of said roller.

6. The device of claim 5 further comprising an opposed pair of surface mountable guide channels for guiding between opposed shower stall surfaces, said bar and said shower  
20 screen within said guide channels when said guide channels are mounted to said opposed shower stall surfaces.

7. The device of claim 6 wherein said guide channels comprise front and rear longitudinal sidewalls extending substantially at right angles from said opposed shower stall surfaces when said guide channels are mounted to said shower stall surfaces, said front longitudinal side walls each rotatable about a longitudinal hinge, said longitudinal hinges adjacent to said shower stall surfaces when said guide channels are mounted to said shower stall surfaces.

8. The device of claim 7 further comprising a roller housing for covering said roller and said shower screen when said shower screen is rolled onto said roller, said roller housing extending longitudinally along the length of said roller and adapted at a first end of said roller housing to support said ratcheting means between said first bracket and said first end of said roller.

9. A retractable shower screen comprising:

(a) a spring-biased roller having first and second ends mountable within an elongate housing for mounting in a shower stall;

(b) first and second brackets, mountable to surfaces in said shower stall corresponding to said first and second ends, for releasable respective mating engagement of said first and second brackets with said first and second ends of said roller;

first spring housing means for longitudinally biasing said first and second brackets in opposed directions against said surfaces in said shower stall;

(c) a flexible sheet having first and second longitudinal edges, said first longitudinal edge of said flexible sheet releasably attachable to said roller between said first and second ends;

(d) sealing means, releasably attachable to said second longitudinal edge of said flexible sheet, for sealing said second longitudinal edge of said flexible sheet to an opposed surface of said shower stall opposed to said surfaces in said shower stall corresponding to said first and second ends;

said spring-biased roller having second spring biasing means for rotationally resilient rotating of said roller, whereby said flexible sheet may be rolled onto and unrolled from said roller;

a ratchet co-operating with said roller, said ratchet releasably engageable whereby when engaged said flexible sheet may only be unrolled from said roller, said engaged ratchet preventing retraction of said flexible sheet onto said roller;

whereby when said ratchet is engaged said flexible sheet may be unrolled from said roller so as to expose within said housing said first longitudinal edge of said flexible sheet, said flexible sheet then detachable from said roller.

10. The device of claim 9 wherein said roller has a longitudinal groove adapted to frictionally receive therein said first longitudinal edge of said flexible sheet and said first longitudinal edge comprises a male frictional mating means adapted to releasably frictionally engage said longitudinal groove in said roller.

11. The device of claim 10 wherein said longitudinal groove and said male frictional mating means are generally "T"-shaped in lateral cross-section and are correspondingly sized for snug releasable mating of said male frictional mating means in said longitudinal groove.

12. The device of claim 11 wherein said longitudinal groove is elongate and said male frictional mating means is elongate so as to extend longitudinally along substantially the length of said roller when releasably mated into said longitudinal groove.
- 5
13. The device of claim 9 wherein said first longitudinal edge of said flexible sheet is detachably mountable along substantially the length of said roller,
- 10 said ratchet comprising a ratchet gear affixed to said first end of said roller and cooperating with a resiliently-biased mating dog.
14. The device of claim 13 wherein said sealing means comprises a bar having first and second longitudinal edges, said first longitudinal edge of said bar releasably attachable to said second longitudinal edge of said flexible sheet, said second longitudinal edge releasably
- 15 attachable to a seal, wherein said seal comprises a strip of resilient material.
15. The device of claim 14 wherein said bar further comprises a longitudinal handle, said longitudinal handle comprising a flange extending outwardly from said bar whereby said flange may be grasped to unroll said flexible sheet from said roller.
- 20
16. The device of claim 15 wherein said ratchet is mountable between said first bracket and said first end of said roller.
17. The device of claim 16 further comprising an opposed pair of surface mountable guide
- 25 channels for guiding between said opposed surfaces, said bar and said flexible sheet within said guide channels when said guide channels are mounted to said opposed surfaces.

18. The device of claim 17 wherein said guide channels comprise front and rear longitudinal sidewalls extending substantially at right angles from said surfaces in said shower stall when said guide channels are mounted to said surfaces in said shower stall, said front longitudinal side walls each rotatable about a longitudinal hinge, said longitudinal hinges adjacent to said surfaces on said shower stall when said guide channels are mounted to said surfaces in said shower stall.
19. The device of claim 18 further comprising a roller housing for covering said roller and said flexible sheet when said flexible sheet is rolled onto said roller, said roller housing extending longitudinally along the length of said roller and adapted at a first end of said roller housing to support said ratchet between said first bracket and said first end of said roller.
20. The device of claim 9 wherein said flexible sheet comprises trimming seams formed in said flexible sheet in parallel spaced apart array parallel to at least one edge of said flexible sheet so as to allow trimming of strips of flexible sheet material from said at least one edge of said flexible sheet whereby said flexible sheet may be sized to accommodate different sized shower stalls.
21. The device of claim 1 wherein said roller has a longitudinal groove adapted to frictionally receive therein said first edge of said shower screen and said first edge comprises a male frictional mating means adapted to releasably frictionally engage said longitudinal groove in said roller.
22. The device of claim 21 wherein said longitudinal groove and said male frictional mating means are generally "T"-shaped in lateral cross-section and are correspondingly sized for snug releasable mating of said male frictional mating means in said longitudinal groove.

23. The device of claim 22 wherein said longitudinal groove is elongate and said male frictional mating means is elongate so as to extend longitudinally along substantially the length of said roller when releasably mated into said longitudinal groove.

5

24. The device of claim 1 wherein said shower screen comprises trimming seams formed in said shower screen in parallel spaced apart array parallel to at least one edge of said shower screen so as to allow trimming of strips of shower screen material from said at least one edge of said shower screen whereby said shower screen may be sized to accommodate different sized shower stalls.

10

Fig. 1

2110824

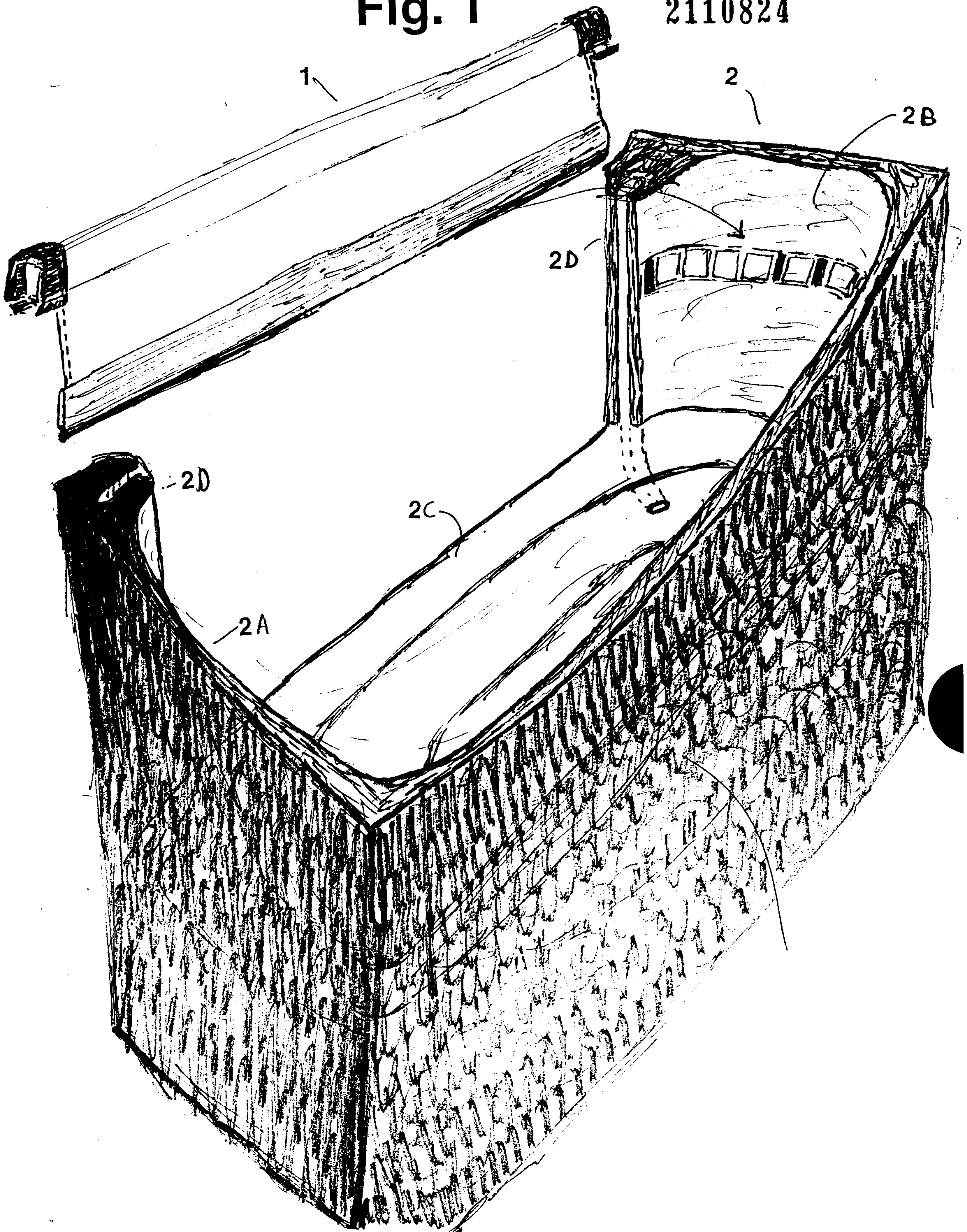

Fig. 2

2110824

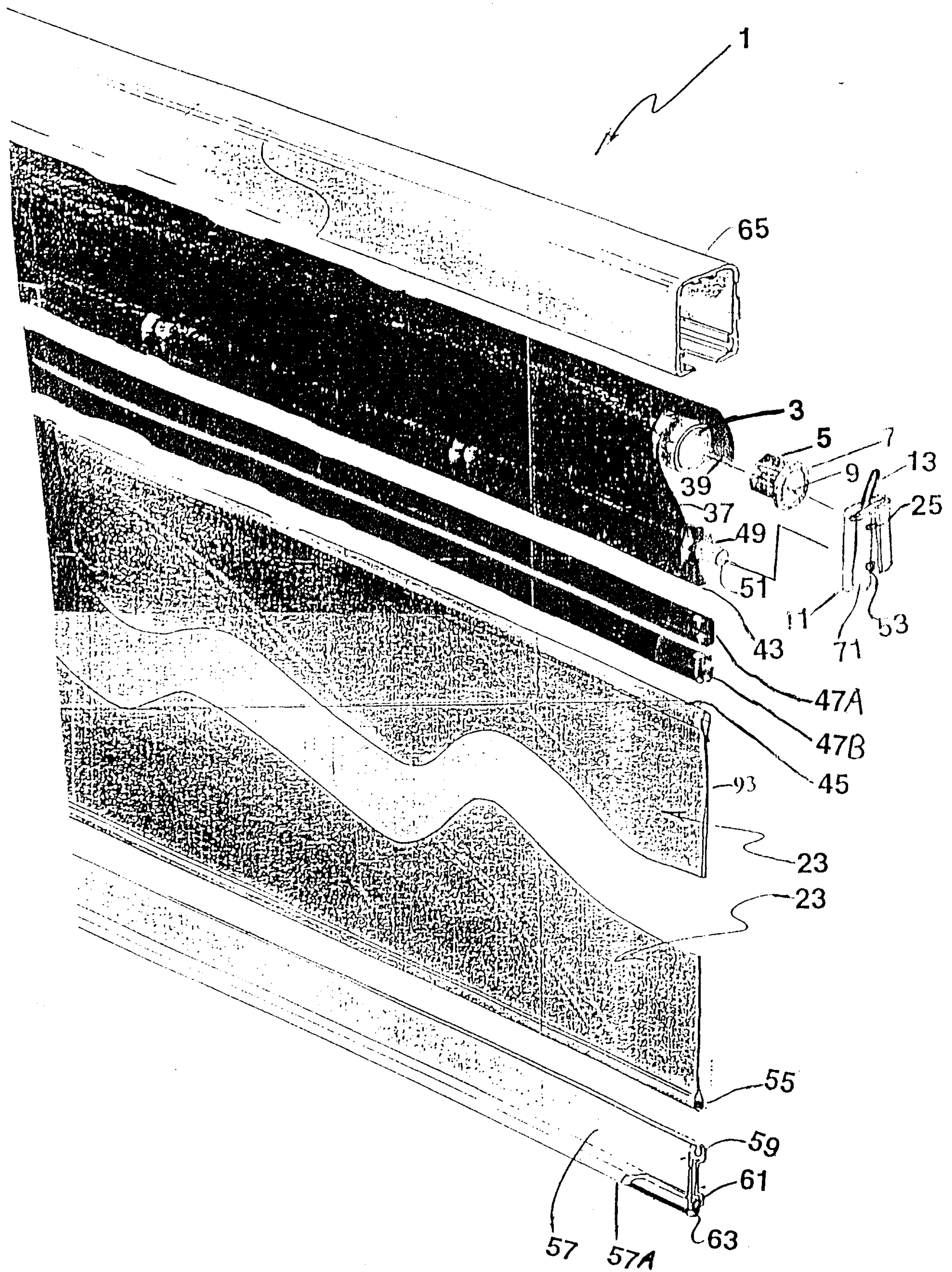

Fig. 3

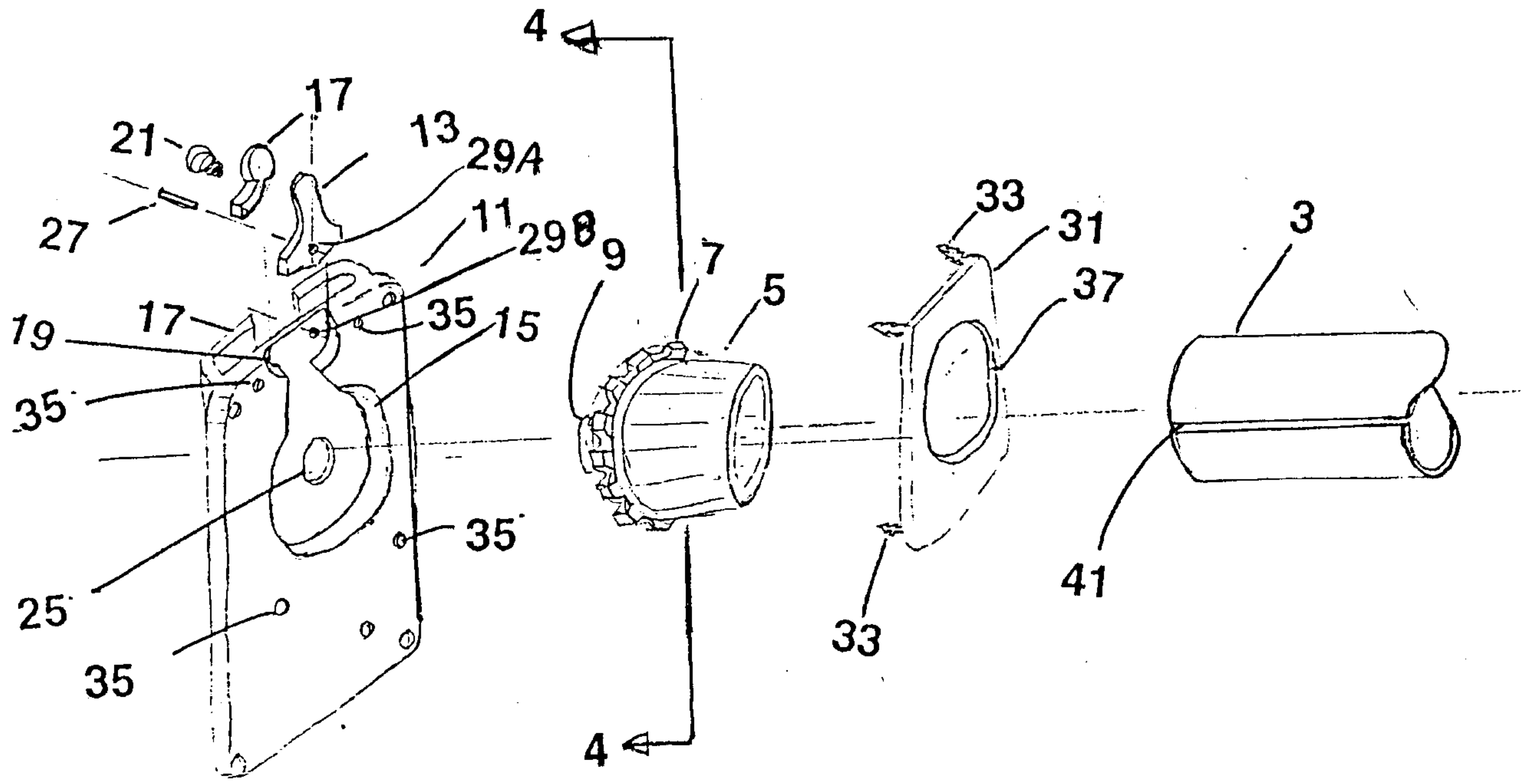
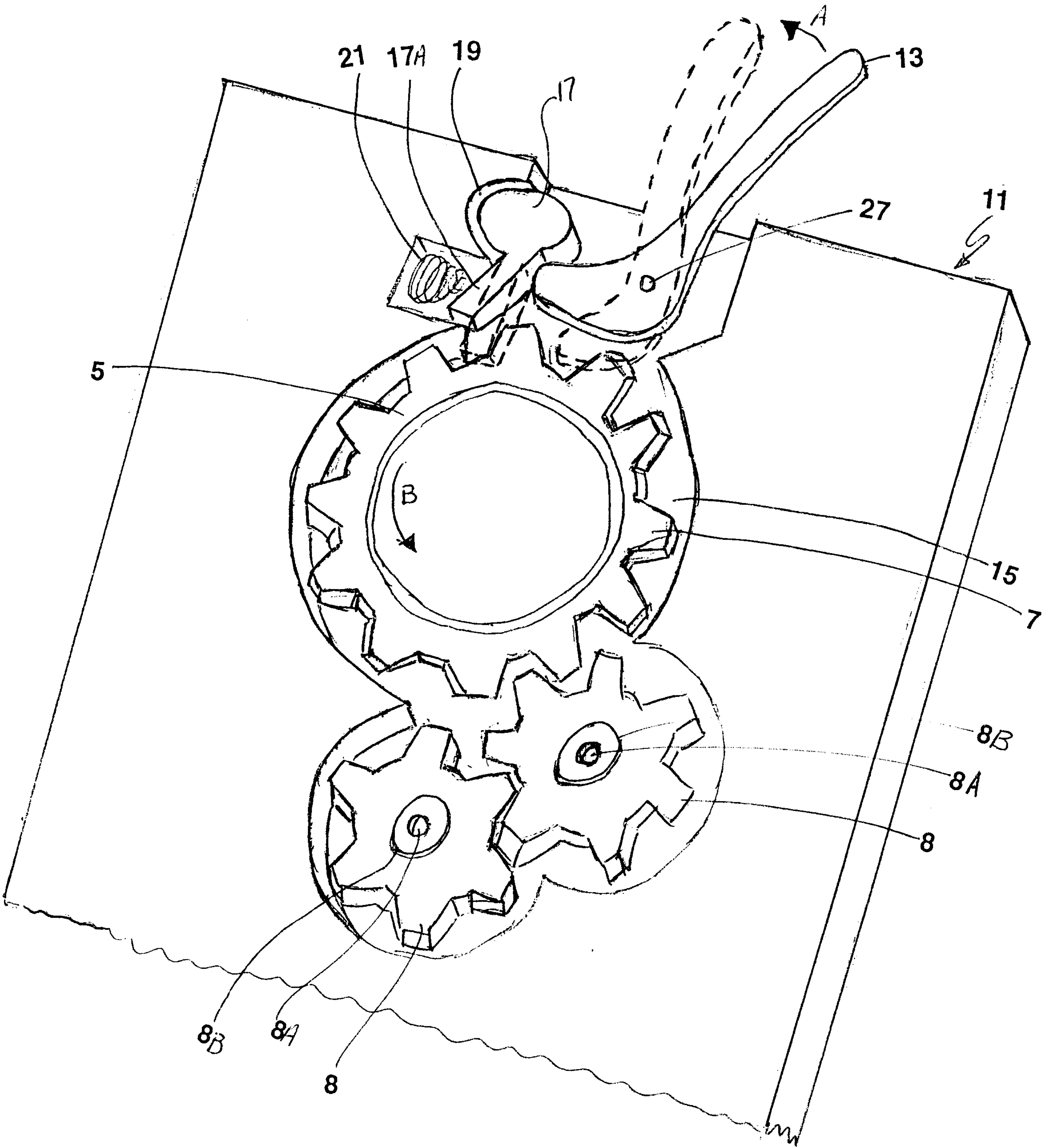

Fig. 4

2110824



# Fig. 5

2110824

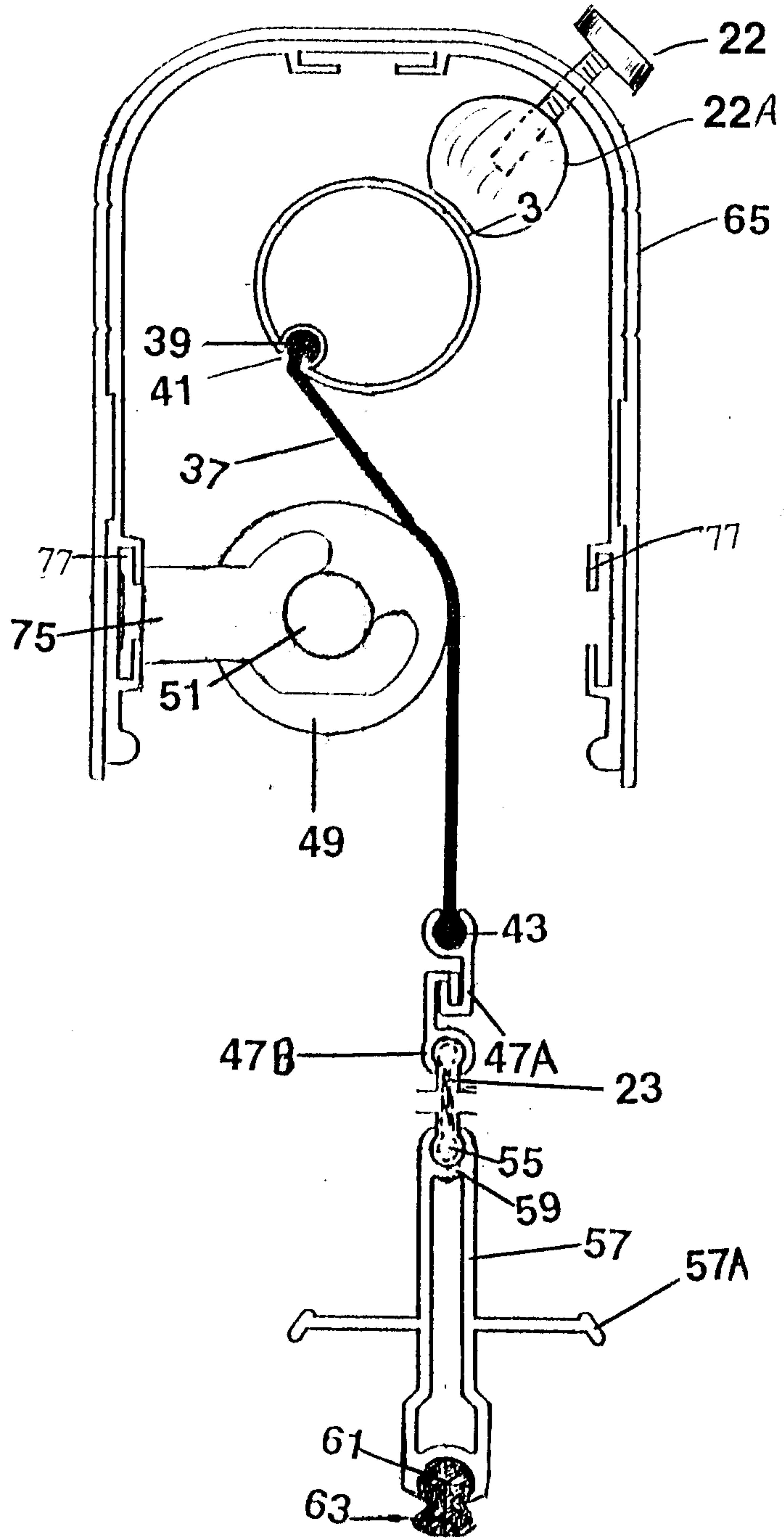

**Fig. 6** 2110824

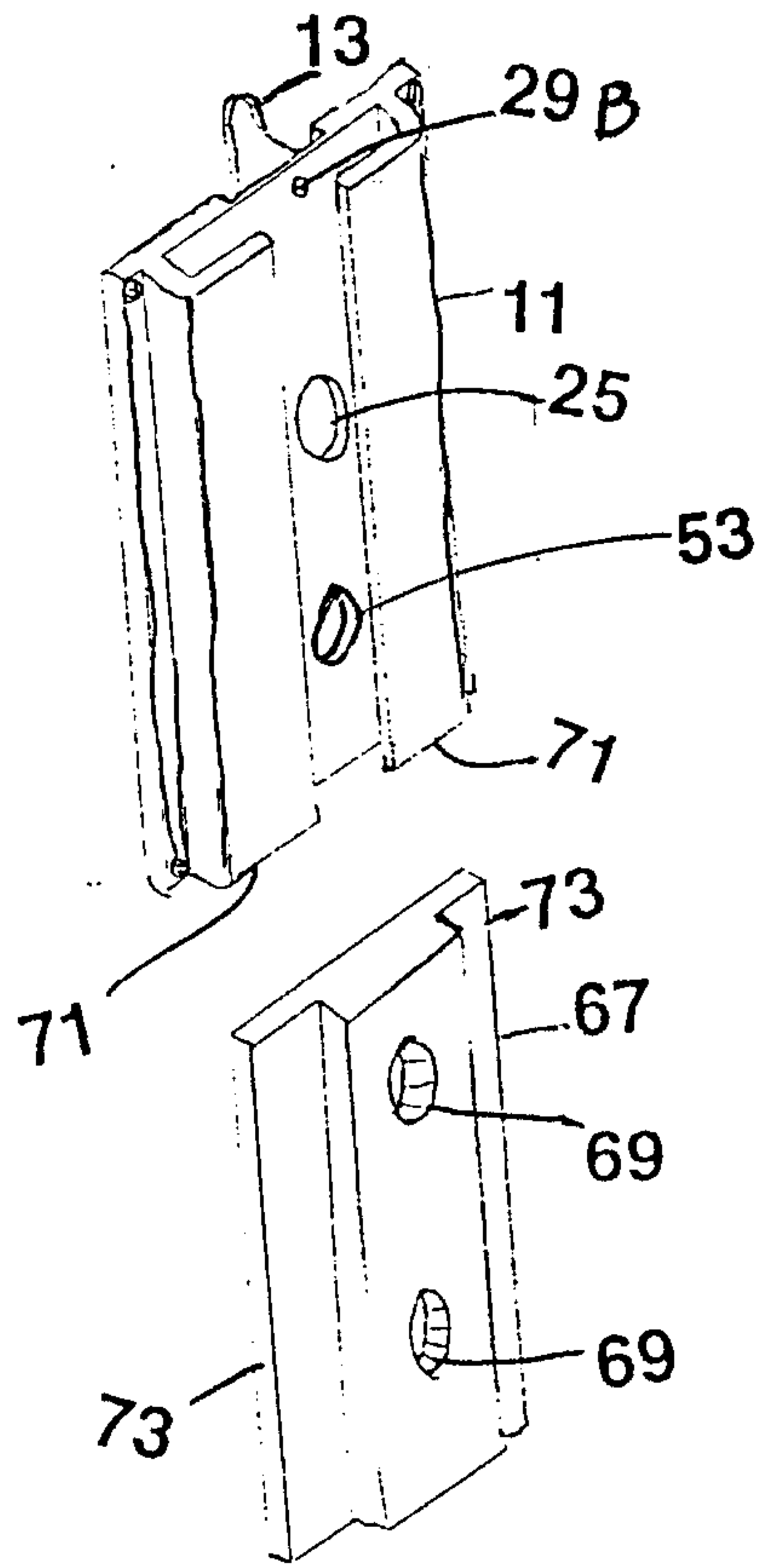

Fig. 7

2110824

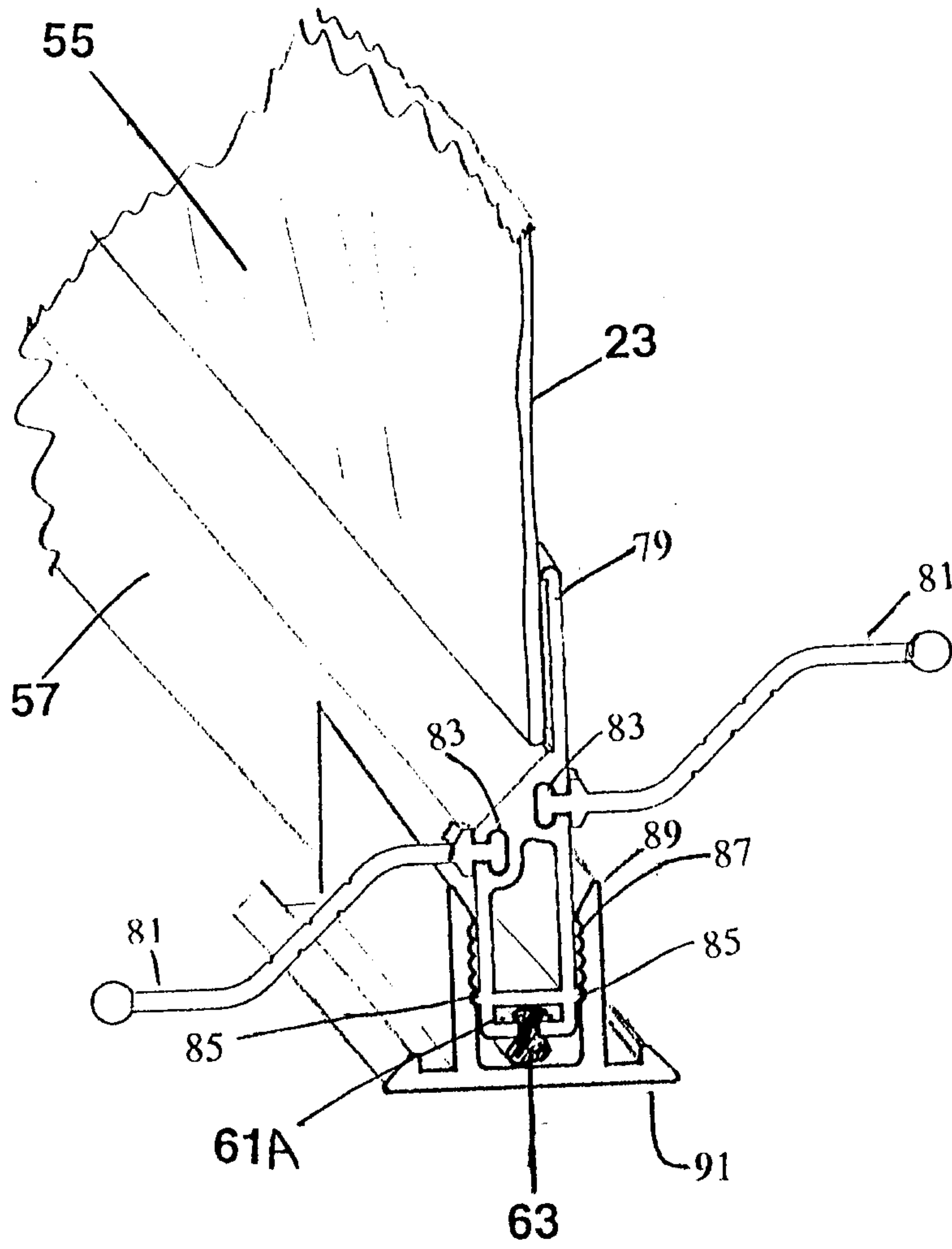
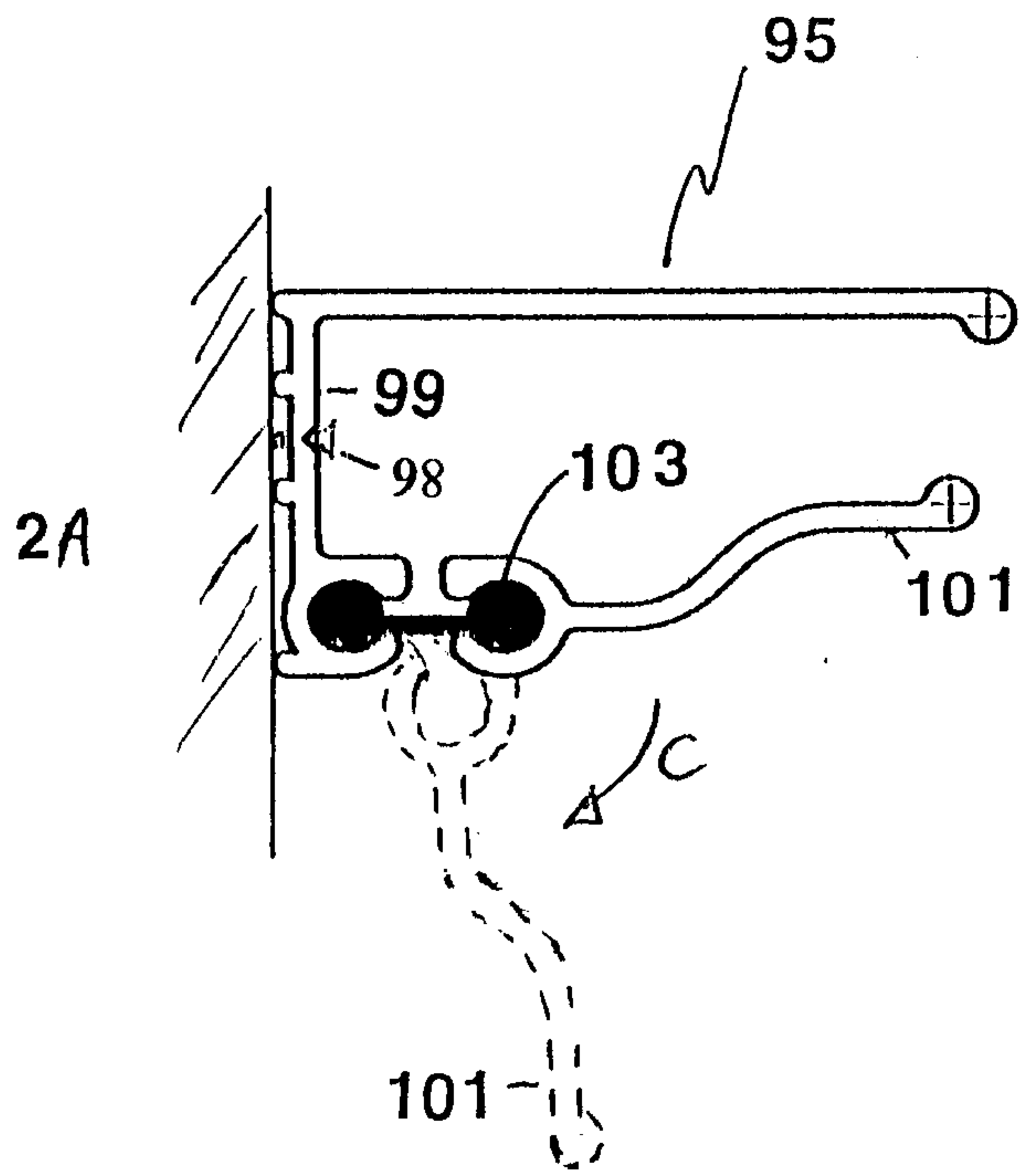
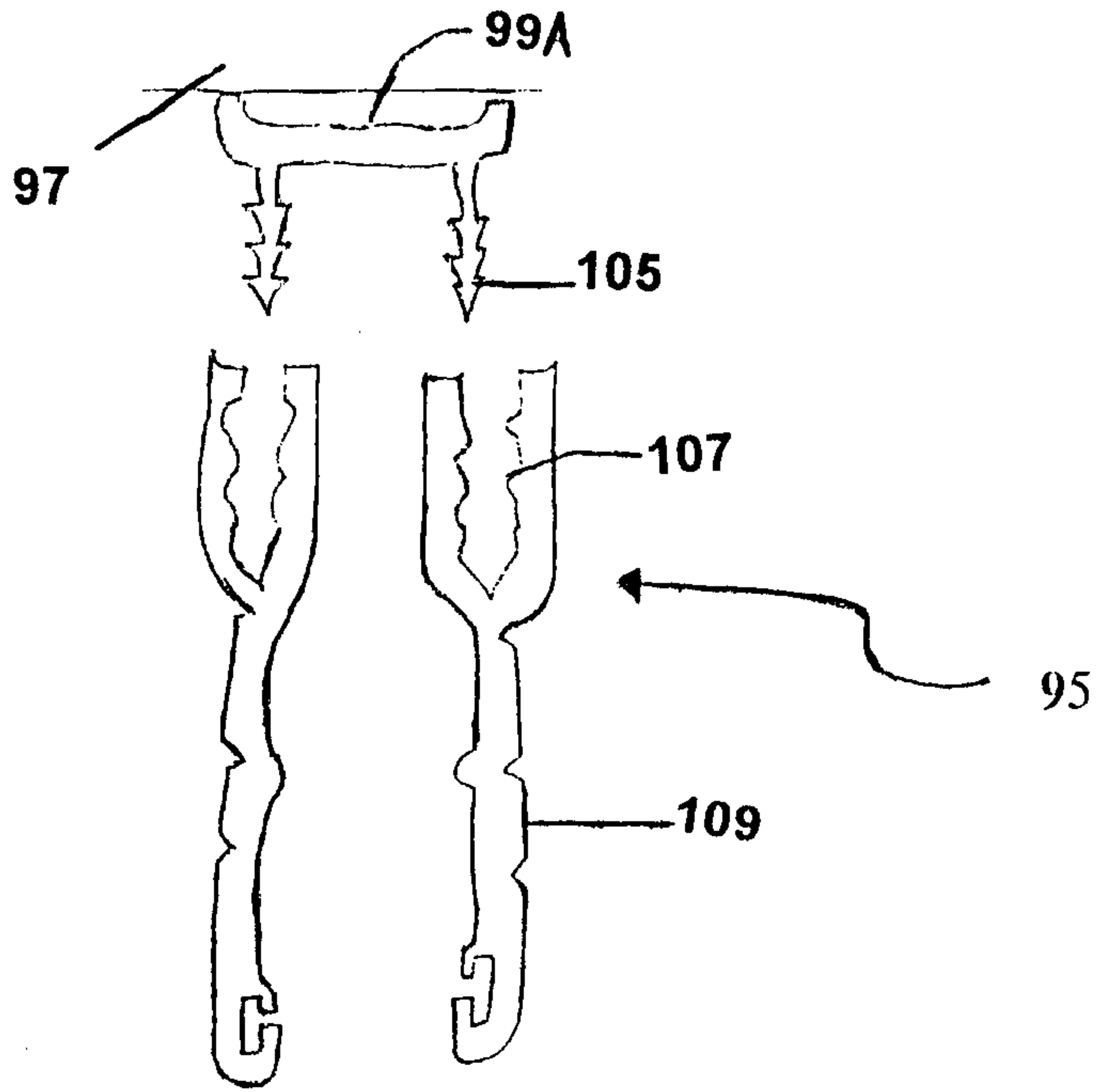

Fig. 8

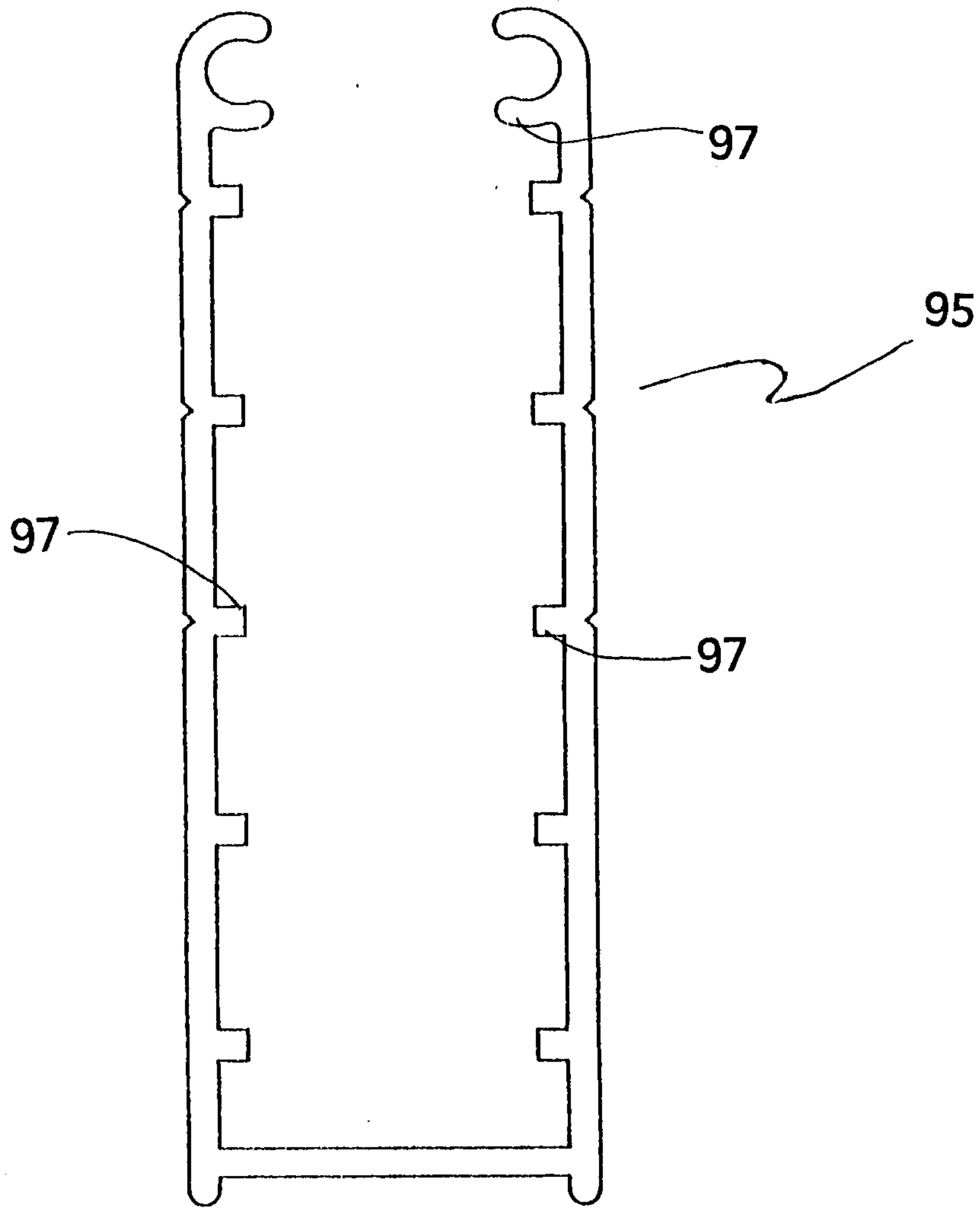

**Fig. 9**

2110824



**Fig. 10**



**Fig. 11** 2110824

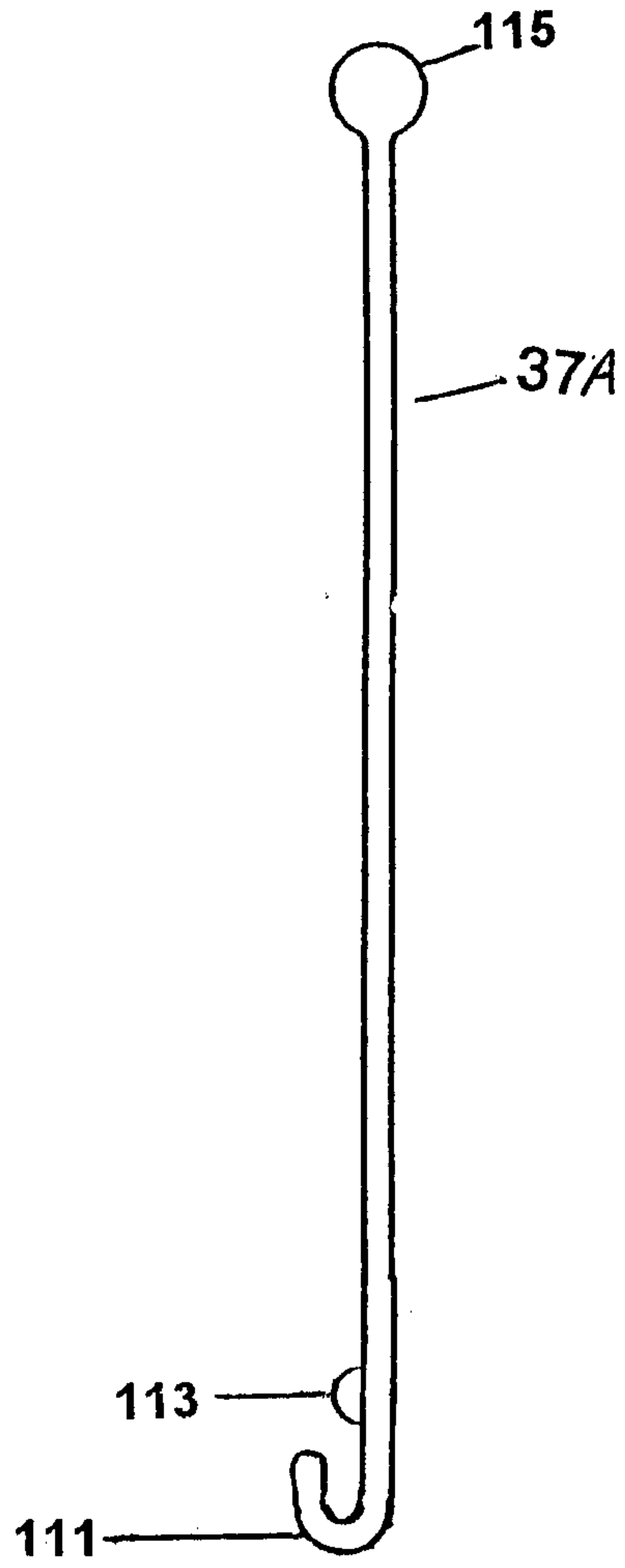

Fig. 12

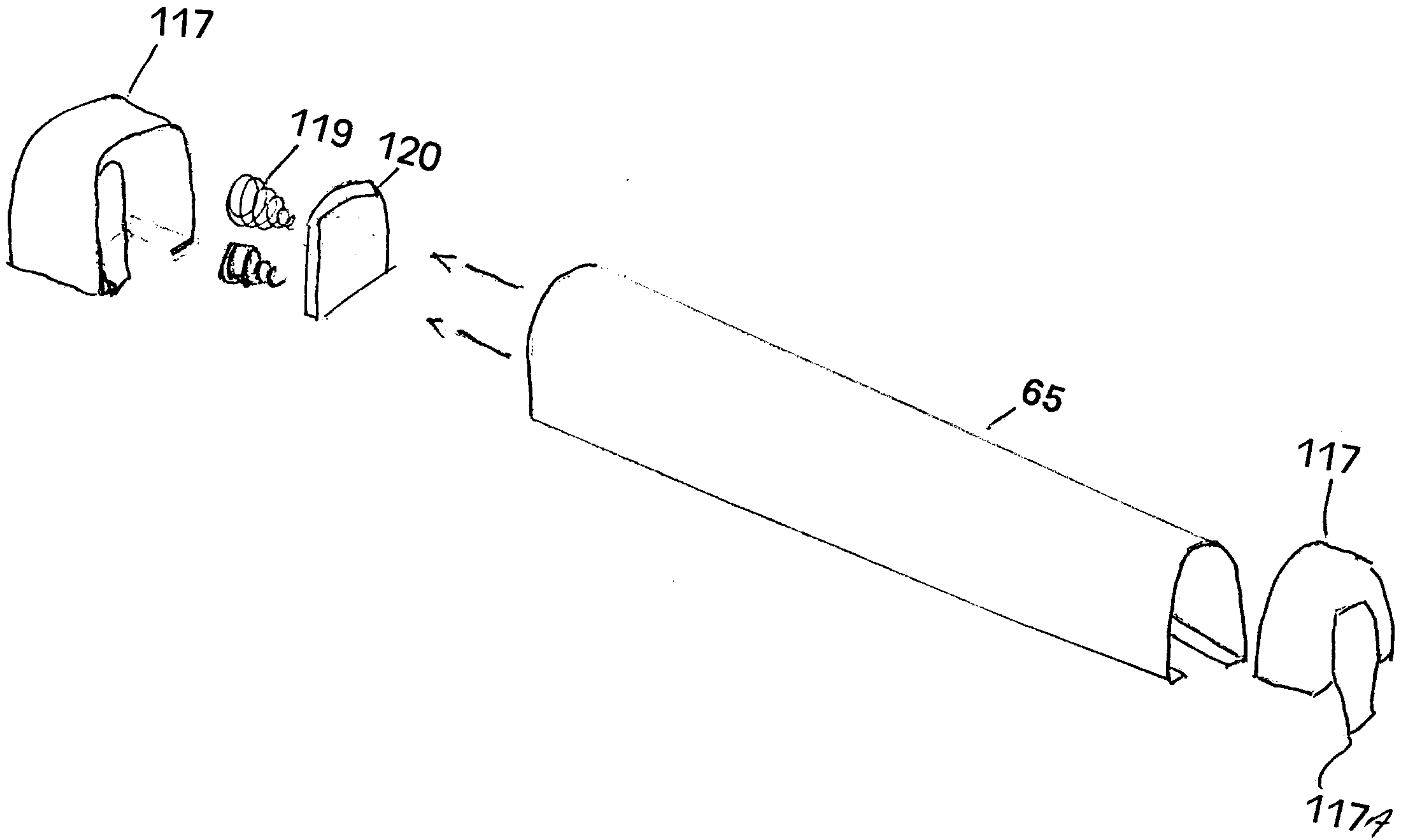

Fig. 13 2110824

