

No. 729,181.

PATENTED MAY 26, 1903.

S. S. JACOBSEN.
GATE VALVE.

APPLICATION FILED JAN. 10, 1902.

NO MODEL.

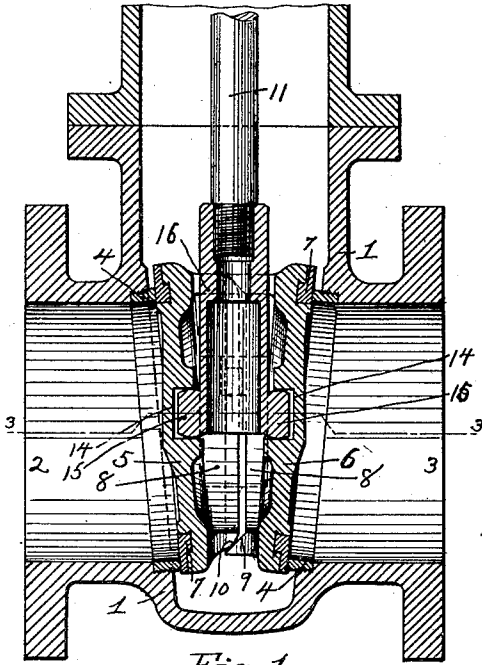

Fig. 1.

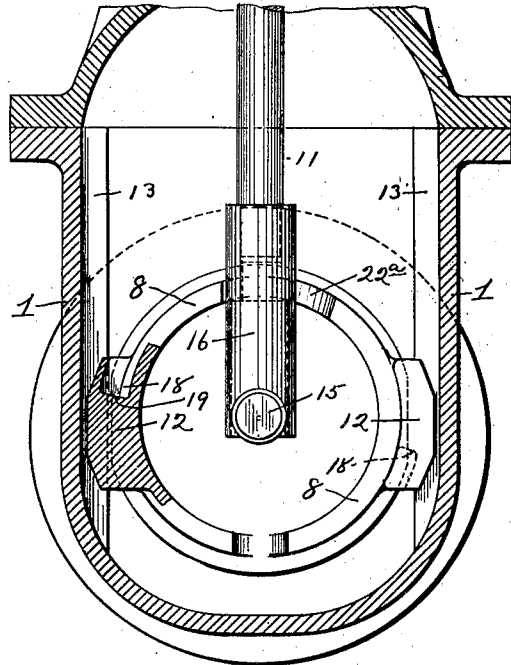

Fig. 2.

Fig. 3.

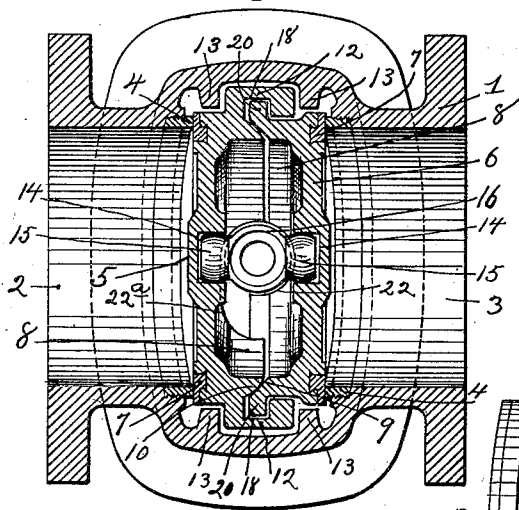
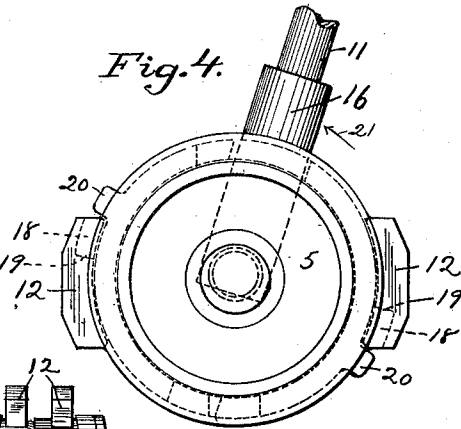

Fig. 4.



Witnesses:

Walter Tamariss
Fred H. Sweet

Fig. 5.

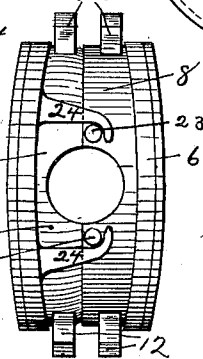

Inventor:
Soren Soren Jacobsen
By Kay & Zotten
Attorneys:

UNITED STATES PATENT OFFICE.

SOREN SANNE JACOBSEN, OF BELLEVUE, PENNSYLVANIA.

GATE-VALVE.

SPECIFICATION forming part of Letters Patent No. 729,181, dated May 26, 1903.

Application filed January 10, 1902. Serial No. 89,153. (No model.)

To all whom it may concern:

Be it known that I, SOREN SANNE JACOBSEN, a resident of Bellevue, in the county of Allegheny and State of Pennsylvania, have invented a new and useful Improvement in Gate-Valves; and I do hereby declare the following to be a full, clear, and exact description thereof.

My invention relates to gate-valves of the type in which the disk is composed of two separate halves, and more particularly to such valves in which the disk-halves have bearing-faces engaging each other, so that they can adjust themselves to make a tight connection with the valve-seats. This type of valve usually is provided with ways or guides in the valve-casing and lugs or flanges on the disk-halves which engage therewith in order to guide the disk in its up and down movements. Should the ways or flanges become worn, there is danger of the disk-halves falling apart or separating to such an extent as to become disengaged from the stem or to otherwise bind or clog in the casing.

The object of my invention is to overcome this difficulty and to provide means which will prevent the disk-halves from falling away from each other or separating to such an extent as to become disengaged from the valve-stem or to otherwise bind or clog in the casing even if the guideways and cooperating flanges or studs become worn excessively or be entirely absent.

To this end my invention comprises, generally stated, a gate-valve having its disk formed of two separate halves and interlocking means on said disk-halves whereby they are held together and prevented from separating or falling apart beyond a certain distance.

In the accompanying drawings, Figure 1 is a longitudinal section through my improved valve and its casing. Fig. 2 is a transverse section of the same. Fig. 3 is an inverted horizontal section on the line 3-3, Fig. 1. Fig. 4 is a detail face view of the disk-halves and stem, and Fig. 5 is a plan view of a modified form of valve.

The valve-casing 1 may be of any suitable shape and construction and is provided with the inlet and outlet ports 2 and 3. This casing opposite the inlet and outlet ports is pro-

vided with the valve-seats 4, said valve-seats being shown as separate brass rings secured to the casing by suitable screw-threaded joints, although they may, if preferred, be formed integral with the casing. These valve-seats are preferably inclined toward each other, as shown, so as to form a wedge-shaped chamber therebetween, in which chamber the valve-disk is received. The valve-disk is formed of two separate halves 5 and 6, having on their outer faces brass or other suitable rings 7, adapted to contact with the valve-seats 4. Each of these disk-halves is preferably provided with an inwardly-projecting annular flange 8, said flanges being wider at the top of the disk than at the bottom, the diminution in size being a gradual one. The flange on one of the disk-halves is shown provided with a beveled bearing-face 9 and that on the other disk-half with a curved bearing-face 10, although both of these faces may be curved, if desired. When these two disk-halves are placed with the flanges 8 in engagement with each other, they will form a wedge-shaped disk corresponding to the wedge-shaped chamber between the inclined valve-seats 4. The flanges 8 are preferably arranged to be practically opposite or in alignment with the valve-seats 4, so that said disk-halves cannot become dished or bent by the pressure.

The disk-halves are moved by an ordinary valve-stem 11, which passes through a stuffing-box in the cover of the valve-casing and either has its upper end screw-threaded to receive a threaded hand-wheel or has the hand-wheel splined to its upper end and has its lower end threaded and engaging a suitable threaded socket in or attached to the disk-halves. With the particular connection of the stem to the disk illustrated it will be necessary to have the stem threaded at its upper end and engaged by a threaded hand-wheel; but my invention is not limited to this construction. By the rotation of the hand-wheel the disk-halves connected to the stem are elevated and lowered, thereby opening and closing the passage through the valve-casing. When the valve is lowered, the disk-halves by reason of their curved or inclined bearing-faces can move upon each other and adjust themselves to the desired position, so as to

form tight connections with the valve-seats. One or both of the disk-halves is provided on its sides with projecting studs or flanges, such as the flanges 12, shown on one of the disk-halves, and the valve-casing is provided with the inwardly-projecting ribs or flanges 13, which form between them a groove in which the projections or flanges 12 may move in the upward and downward movement of the valve, thereby guiding the latter and preventing the disk-halves from falling away from each other or separating to an undue extent.

The valve as thus far described is old and is practically the same as that covered by Letters Patent No. 565,239, granted to W. H. H. Sheets, August 4, 1896, and forms no part of my invention. My invention is an improvement on this and all other forms of gate-valves having a disk composed of two separate halves and is designed to prevent the undue separation of the disk-halves in case the cooperating guides 12 and 13 become excessively worn or are entirely absent.

The valve-stem 11 may be secured to the disk-halves in the manner shown in the above-named patent to Sheets, although I prefer to make this connection in a slightly-modified form. Each of the disk-halves 5 and 6 is shown provided with a socket or recess 14, which sockets are adapted to be engaged by lugs or projections 15 on the stem-section 16, secured in any convenient manner to the stem proper, 11—as, for instance, by having the latter screw into the upper end thereof. The lugs or projections 15 are preferably formed with rounded bearing-surfaces, as shown, so that they are, in fact, sections of a sphere, and the sockets or recesses 14 may also be formed with curved or rounded faces, thereby permitting said disk-halves to move freely on the stem to adjust themselves to the seats 4. Any other well-known means for connecting the stem to a disk composed of two separate halves may be used, if desired.

The means for preventing the disk-halves from falling away from each other or separating to an undue extent may take various forms, it being merely necessary the said means engage both of the disk-halves in such a manner that they can move away from each other only to a limited extent, and preferably the means will be cooperating interlocking portions of the two halves themselves. The interlocking portions (shown in Figs. 1 to 4) are formed on the projecting flanges 12, although this is not necessary. As illustrated, the disk-half 5 has the projecting flanges 12 formed very thick and provided with sockets or recesses 18, which do not extend for the entire length or depth of said flanges, but are limited by bottom walls 19. The recesses or sockets 18 in the two opposite flanges 12 are projected from opposite sides of the said flanges, as shown in Figs. 2 and 4. The disk-half 6 is provided with suitably-shaped lugs 20 to fit into the recesses or sockets 18. In

assembling said disk-halves the said disks are first placed in the position shown in Fig. 4 and then are given a partial rotation in the direction of the arrow 21, thereby carrying the lugs or projections 20 on the one disk-half into the sockets or recesses 18 in the other disk-half, whereby said disk-halves are locked together. The projections or lugs 20 fit into the sockets or recesses 18 loosely, so that a certain amount of side movement is permitted, but not sufficient to enable the disk-halves to separate to such an extent that the stem can become disengaged therefrom. The disk-half 6 has its flange 8 provided with a semicircular recess 22, which engages the stem-section 16, and the latter when the disk is in place prevents rotation of said disk-half, and the other disk-half 5 has its flange 8 cut away, as at 22^a, so as to permit the disk-halves rotating on each other to a sufficient extent to interlock the lugs or projections 20 with the recesses 18, said disk-half 5 being prevented from rotation when in place by the edges of its flanges 12 bearing against the inner walls of the valve-casing.

In Fig. 5 the interlocking portions of the two disk-halves are shown as studs or projections 23 on one of said disk-halves and cooperating hook-shaped arms 24 on the other disk-half, which hooks take over the studs or projections 23, and thus lock the two disk-halves together. The studs or projections 23 are preferably formed on the annular flange 8; but this is not essential, as said studs might be formed on the end of arms projecting out from the disk-half.

The interlocking portions 23 and 24, Fig. 5, are shown as at the upper sides of the disk-halves, although they need not necessarily be located at that position. When they are located at the upper side, however, it may be desirable to provide suitable means for preventing the lower sides from separating to such an extent that the halves will bind or clog in the casing. Any suitable means for this purpose may be used.

In all the forms of my invention, as illustrated and described, the disk-halves are preferably free to move relatively to each other and on the valve-stem, so as to seat themselves firmly on the valve-seats. Should the guides 12 and 13 be absent or become unduly worn, the disk-halves can nevertheless not separate or fall away from each other to such an extent that the lugs 15 on the valve-stem would escape from the sockets or recesses 14 in the disk-halves. As there is no, or very little, wear between the interlocking means on the disk-halves, said interlocking means will always insure the proper engagement between the stem and disk-halves. It is not necessary that the stem-section 16 be of a separate piece from the stem 11, as it might be formed integral therewith. Neither is it essential that the lugs 15 be on the stem and the sockets 14 in the disk-halves, as these parts may be reversed or be substantially such

as shown in the patent to Sheets, above referred to, or they may be replaced by any well-known means for connecting the stem to a disk composed of separate halves. Neither
 5 are the interlocking means shown limited to disk-halves having bearing-faces engaging each other, but are equally applicable to all gate-valves which have disks composed of two separate halves.

10 What I claim as my invention, and desire to secure by Letters Patent, is—

1. A gate-valve having a disk composed of two separate halves, a valve-stem, cooperating lugs and sockets on said stem and disk-
 15 halves, said disk-halves being provided with a pair of reversely-arranged sockets or recesses and a pair of lugs or projections adapted to enter said sockets or recesses and lock the disk-halves together.

2. A gate-valve having a disk composed of two separate halves, a valve-stem, means for securing said disk-halves to said stem one of
 20 said disk-halves being provided with reversely-arranged sockets or recesses open at one end, and projections on the other disk-half adapted to enter said sockets or recesses and lock the disk-halves together.

3. A gate-valve having a disk composed of two separate halves having bearing-faces engaging one another, a valve-stem, cooperating
 30 lugs and sockets on said stem and disk-halves, opposite radial projections on one of said disk-halves provided with reversely-arranged sockets or recesses open at one end,

and radial projections on the other disk-half
 35 adapted to enter said sockets or recesses, one of said disk-halves being provided with a cut-away portion through which the stem passes to permit the rotation of said disk-halves to
 40 lock and unlock the same.

4. A gate-valve having a casing and valve-seats therein, a disk composed of two separate halves, a valve-stem, cooperating lugs and sockets on said stem and disk-halves,
 45 guides formed in the side of the valve-casing, and cooperating projections on the disk-halves for engaging said guides, the projections on one of said disk-halves being formed with sockets or recesses and the projections
 50 on the other disk-half being adapted to enter said sockets or recesses to lock the said halves together.

5. A gate-valve having a casing and valve-seats therein, a disk composed of two separate halves, a valve-stem, means for securing
 55 said disk-halves to said stem, cooperating guides on the disk-halves and valve-casing, said disk-halves being provided with a pair of reversely-arranged sockets or recesses and a pair of lugs or projections adapted to enter
 60 said sockets or recesses and lock the disk-halves together.

In testimony whereof I, the said SOREN SANNE JACOBSEN, have hereunto set my hand.

SOREN SANNE JACOBSEN.

Witnesses:

F. W. WINTER,
 ROBERT C. TOTTEN.