



HU000033224T2

(19) **HU**(11) Lajstromszám: **E 033 224**(13) **T2****MAGYARORSZÁG**  
Szellemi Tulajdon Nemzeti Hivatala**EURÓPAI SZABADALOM**  
**SZÖVEGÉNEK FORDÍTÁSA**

- (21) Magyar ügyszám: **E 11 807982**
- (22) A bejelentés napja: **2011. 11. 15.**
- (96) Az európai bejelentés bejelentési száma:  
**EP 20110807982**
- (97) Az európai bejelentés közzétételi adatai:  
**EP 2640609 A1** **2012. 05. 24.**
- (97) Az európai szabadalom megadásának meghirdetési adatai:  
**EP 2640609 B1** **2016. 11. 02.**
- (51) Int. Cl.: **B60R 13/00** (2006.01)  
**H01Q 1/42** (2006.01)  
**C23C 14/34** (2006.01)  
**B44C 5/00** (2006.01)  
**C23C 14/20** (2006.01)
- (86) A nemzetközi (PCT) bejelentési szám: **PCT/IB 11/002859**
- (87) A nemzetközi közzétételi szám: **WO 12066417**

(30) Elsőbbségi adatok: <b>413551 P</b> <b>2010. 11. 15.</b> <b>US</b> <b>201113292708</b> <b>2011. 11. 09.</b> <b>US</b>	(73) Jogosult(ak): <b>Zanini Auto Grup, S.A., 08150 Parets del Vallés (ES)</b>
(72) Feltaláló(k): <b>MAYER-PUJADAS, Augusto, E-08150 Parets del Vallés (Barcelona) (ES)</b>	(74) Képvisező: <b>SBGK Szabadalmi Ügyvivői Iroda, Budapest</b>

(54) **Dekoratív radarantenna-burkolat gépjármű-technikai alkalmazásra**

Az európai szabadalom ellen, megadásának az Európai Szabadalmi Közlönyben való meghirdetésétől számított kilenc hónapon belül, felszólalást lehet benyújtani az Európai Szabadalmi Hivatalnál. (Európai Szabadalmi Egyezmény 99. cikk(1))

A fordítást a szabadalmas az 1995. évi XXXIII. törvény 84/H. §-a szerint nyújtotta be. A fordítás tartalmi helyességét a Szellemi Tulajdon Nemzeti Hivatala nem vizsgálta.

(19)



(11)

**EP 2 640 609 B1**

(12)

**EUROPEAN PATENT SPECIFICATION**

(45) Date of publication and mention of the grant of the patent:  
**02.11.2016 Bulletin 2016/44**

(51) Int Cl.:  
**B60R 13/00** (2006.01)      **H01Q 1/42** (2006.01)  
**B44C 5/00** (2006.01)      **C23C 14/34** (2006.01)  
**C23C 14/20** (2006.01)

(21) Application number: **11807982.1**

(86) International application number:  
**PCT/IB2011/002859**

(22) Date of filing: **15.11.2011**

(87) International publication number:  
**WO 2012/066417 (24.05.2012 Gazette 2012/21)**

**(54) DECORATIVE RADOME FOR AUTOMOTIVE VEHICULAR APPLICATIONS**

DEKORATIVES RADOM FÜR AUTOMOBILANWENDUNGEN

RADOME DÉCORATIF POUR APPLICATIONS DANS DES VÉHICULES AUTOMOBILES

(84) Designated Contracting States:  
**AL AT BE BG CH CY CZ DE DK EE ES FI FR GB GR HR HU IE IS IT LI LT LU LV MC MK MT NL NO PL PT RO RS SE SI SK SM TR**

(74) Representative: **Carpintero Lopez, Francisco et al Herrero & Asociados, S.L.**  
**Alcalá 35**  
**28014 Madrid (ES)**

(30) Priority: **15.11.2010 US 413551 P**  
**09.11.2011 US 201113292708**

(56) References cited:  
**EP-A2- 1 560 289**      **WO-A1-2010/084733**  
**JP-A- 2009 090 639**      **JP-A- 2010 188 987**

(43) Date of publication of application:  
**25.09.2013 Bulletin 2013/39**

- **ANONYMOUS: "Metalloid", Wikipedia INTERNET ARTICLE, 3 November 2010 (2010-11-03), XP002671379, Retrieved from the Internet: URL:<http://web.archive.org/web/20101103065838/http://en.wikipedia.org/wiki/Metalloid> [retrieved on 2012-03-13]**

(73) Proprietor: **Zanini Auto Grup, S.A.**  
**08150 Parets del Vallés (ES)**

(72) Inventor: **MAYER-PUJADAS, Augusto**  
**E-08150 Parets del Vallés (Barcelona) (ES)**

**EP 2 640 609 B1**

Note: Within nine months of the publication of the mention of the grant of the European patent in the European Patent Bulletin, any person may give notice to the European Patent Office of opposition to that patent, in accordance with the Implementing Regulations. Notice of opposition shall not be deemed to have been filed until the opposition fee has been paid. (Art. 99(1) European Patent Convention).

## Description

### BACKGROUND OF THE INVENTION

#### 1. Field of the Invention

**[0001]** The invention relates to a radome or cover for protecting a radar device while presenting a decorative metallic image, especially for radar devices disposed behind the front grill of an automobile.

#### 2. Antecedents of the Invention

**[0002]** In general, radio transmitter-receiver devices, such as a millimeter-wave radar, have been employed as sensors for vehicular collision avoidance and adaptive cruise control systems.

**[0003]** In a radar system or the like that measures obstacles in front of an automobile and the distance between automobiles, the antenna was preferably positioned in the center at the front of the vehicle to obtain maximum performance. Although the radar antenna could be installed near the front grill of automobile, it was preferable to conceal the antenna from view due to its non-aesthetic appearance and to shield the antenna from external environmental factors such as weather and airborne contaminants.

**[0004]** In order protect the antenna and avoid radio interference and signal losses of the radar device, it has been proposed to provide a radar window capable of transmitting radio waves in the front grill corresponding where the radar antenna was located. This allowed radio waves to pass in and out through the window. However, the radar window diminished the appearance of the front grill due to the interruption of the pattern of the grill structural elements. Further, unsightly internal portions of the vehicle, like the radar transmitter-receiver, could be seen through the radar window.

**[0005]** In U.S. Pat. No. 6,328,358 unity between the radar window and the front grill body was provided. The radar window as disclosed in U.S. Pat. No. 6,328,358 was formed by laminating a plurality of resin layers formed with concavity and convexity. This component provided an impression by a metal layer deposited with concavity and convexity between the resin layers such that the fin member of the front grill appeared to extend across the radar window without interruption.

**[0006]** Indium was used as a metal deposited in such radar window. When depositing indium on a deposit member, indium was not deposited on the surface in a uniform film manner, but deposited in a nanometric insular manner. In other words, when indium was deposited on the deposit member, the surface of the deposit member comprised a nanometric combination of a deposit portion where indium was deposited in an insular manner and a non deposit portion where nothing was deposited.

**[0007]** In this case, radio waves could pass in and out through the non-deposit portion and the surface of the

deposit member could be recognized upon viewing as a member that had metallic luster, since the deposit portion had indium deposited in a nanometric insular manner.

**[0008]** This selective way of deposition complicated the process of application of the indium metals. Further radio waves did not pass in and out satisfactorily when the deposit portions were formed extremely close together. The conductivity of the metals required the use of low density evaporation methods such thermal evaporation: These methods did not guarantee a uniform deposition in thickness throughout the member or between members produced in the same batch. Other methods of deposition would guarantee uniform insular deposition such sputtering, but sputtering provided a metal density that generates a high level of attenuation, making the system useless for a radome application in front of a radar antenna.

**[0009]** U.S. Pat. No. 6,328,358 disclosed a thin metallic layer comprising indium deposited on a metal portion area that could be viewed from the outside at a plastic-plated member for the beam path of a radar device. However, it was necessary to ensure a bright design and the reliability of durability for radio transmittance by forming a stable protective layer so as not to allow the indium bright film layer to undergo exfoliation or be damaged by an external force, or to be corroded by an external environmental stress such as water or polluted air.

**[0010]** This was due to the following: indium is a very soft metallic material with a value of 1.2 in the Mohs hardness scale; indium corrodes under the aforementioned environmental stress since it is basically a metallic material; it is necessary to ensure the reliability of durability by securing the film thickness with certainty such that the bright-effect design of indium can be obtained without thickening the indium film layer more than is necessary, since a radio transmission loss occurs as a conductivity loss based on the fact that indium is basically a metallic material; and the indium layer melts due to the heat of molten resin when successively conducting secondary formation of the lining resin on a resin-molded component in which a film is formed on the surface of a base body in advance, since the melting point of indium is 156°C., which is extremely low, for example.

**[0011]** Although indium film is suitable for a film of an emblem or the like as it shows a metallic color, it poses problems in that it readily experiences exfoliation and lacks durability and abrasion resistance. Also, indium film may corrode, since it is basically a metal. Thus, when a ceramic film comprising silicon dioxide is disposed, the durability is improved and the film, or paint, can be protected. However, the ceramic film comprising silicon dioxide is colorless, so that the appearance of a metallic color, for example, cannot be provided.

**[0012]** WO2010084733 A1 discloses a low-cost radio wave-transmitting decorative member according to the preamble of claim 1, which has radio wave transmission properties and mirror-like metallic luster which is not easily lost. Also disclosed is a method by which the radio

wave-transmitting decorative member can be efficiently and stably produced. Specifically disclosed are: a radio wave-transmitting decorative member (1) which comprises a base (12), a transparent organic material layer (16), and a light-reflecting layer (14) which is provided between the base (12) and the transparent organic material layer (16), and formed from an alloy of silicon or germanium and a metal; and a production method wherein the light-reflecting layer (14) is formed by DC magnetron sputtering using a target that is formed from an alloy of silicon or germanium and a metal.

#### SUMMARY OF THE INVENTION

**[0013]** A molded radome for the beam path of a radar device with low radio transmission loss and improved resistance to attack by the environmental elements comprises a base layer or body composed of a resin and a decoration layer bearing an image. The decoration layer is characterized with bright metallic looking coat disposed on the surface of the base layer or body. The decoration layer is composed of a metalloid such as germanium or a germanium alloy.

**[0014]** From the foregoing compendium, it will be appreciated that it is an aspect of the present invention to provide a decorative radome for automotive vehicular applications of the general character described which is not subject to the disadvantages of the antecedents of the invention aforementioned.

**[0015]** It is a feature of the present invention to provide a decorative radome for automotive vehicular applications of the general character described that offers stable effects as a product over a long period of time, which includes a molded component providing a low level of radio transmission loss and distortion for the beam path of a radar device.

**[0016]** It is a consideration of the present invention to provide a decorative radome for automotive vehicular applications of the general character described that shows a metallic bright color for the beam path of a radar device.

**[0017]** Another consideration of the present invention is to provide a decorative radome for automotive vehicular applications of the general character described which is relatively low in cost.

**[0018]** A still further aspect of the present invention is decorative radome for automotive vehicular applications of the general character described having relatively high durability.

**[0019]** Another aspect of the present invention is to provide a decorative radome for automotive vehicular applications of the general character described having a bright decoration layer with a metallic appearance with low radio transmission loss and improved resistance to wear and/or corrosion.

**[0020]** Further aspects, features and considerations of the present invention in part will be obvious and in part will be pointed out hereinafter.

**[0021]** With these ends in view, the invention finds em-

bodiment in the various combinations of elements, arrangements of parts and series of steps by which the aforesaid aspects, features and considerations and certain other aspects, features and considerations are attained, all with reference to the accompanying drawings and the scope of which will be more particularly pointed out and indicated in the appended claims.

#### BRIEF DESCRIPTION OF THE DRAWINGS

##### **[0022]**

FIG. 1 is a fragmentary isometric view of a vehicle having a decorative radome constructed in accordance with and embodying the invention positioned within a grill assembly and a radar antenna positioned behind the radome;

FIG. 2 is a schematized sectional view through a portion of the radome positioned within the grill and showing the radar antenna positioned within the vehicle behind the radome and with a detected object in front of the vehicle, with a schematized representation of emitted and reflected radar waves; and

FIG. 3 is an isometric view of the radome showing a base layer, a decoration layer and a protective cover layer.

#### DESCRIPTION OF THE PREFERRED EMBODIMENT

**[0023]** Radomes cover microwave antennas to protect the antennas from rain, ice, wind and other environmental conditions and are also provided to conceal the antennas from view. A principal requirement is that the radome be transparent to radar or radio waves or provide but minimal signal attenuation.

**[0024]** The present invention relates to the use of a metalloid or metalloid alloy for a radome decoration layer. The present invention employs, for example, as a radome decoration layer, germanium, a metalloid of high electric resistivity, i.e. 1 ohm m at 20°C.

**[0025]** Due to the high melting point of germanium 938.25°C and its boiling point 2833°C., this element cannot be deposited using thermal evaporation methods like the ones applied in the case of indium. Nevertheless, this constitutes an advantage.

**[0026]** Pursuant to the present invention, sputtering is the method employed for the deposition of germanium over a substrate comprising a base layer or body. Due to the nature of sputtering deposition, uniformity of the decoration layer can be guaranteed.

**[0027]** The decorative radome for automotive vehicular applications of the present invention comprises a molded radome having a base layer or body composed of a resin and a bright decoration layer on the surface of the base layer or body, the bright decoration layer being composed of a metalloid, such as, germanium and/or a germanium alloy.

**[0028]** By using the layer of germanium and/or germanium alloy, radio transmittance can be improved by several orders of magnitude as compared with an indium layer or other metals such as, tin, as proposed in EP 1560288 A2.

**[0029]** The high conductivity of metals like indium or tin, combined with the variability of thickness of the deposition methods typically used, required each radar window to be tested for radar beam transmissivity during the final stage of production. This increased dramatically the manufacturing cost of the radome.

**[0030]** The very low conductivity of a germanium decoration layer of the present invention, due to the metalloid nature of germanium, combined with the sputtering deposition method, allows one to avoid the requirement for testing of each radome.

**[0031]** Due to the fact of using a metalloid, it not necessary to create areas where no metallic decoration is applied, since the metalloid performs like a dielectric with respect to radar waves. This reduces process complexity in the manufacturing of the radome of the present invention, as compared with the method exemplified in patent JP 2003-252137A.

**[0032]** With reference now in detail to the drawings, wherein like numerals will be employed to denote like components throughout, as illustrated in FIG. 1, the reference numeral 10 denotes generally a decorative radome constructed in accordance with and embodying the invention configured for mounting within a grill assembly 12 of a motor vehicle 14. Positioned within the vehicle 14 behind and in registration with the decorative radome 10 is a radar antenna 16.

**[0033]** FIG. 2 comprises a cross section of the radome 10 and illustrating the beam path of a radar antenna according to the present invention. Preferably, a substrate comprising a layer or base body 18 having a proximal face and a distal face is molded of a transparent or non-transparent resin having low radio transmission loss or a resin resulting in low dielectric loss. On the surface of the proximal face, a bright decoration layer 20 comprising germanium and/or a germanium alloy is disposed using sputtering deposition.

**[0034]** Pursuant to the invention, the decoration layer 20 is of uniform thickness. Ornamentation, such as a vehicle emblem, is provided by shaping the proximal face of the base layer or body 18 with projecting and or indented surface configurations.

**[0035]** As is well known to those of skill in the art, sputtering deposition is a physical vapor deposition method wherein atoms or molecules are ejected from a source or target by high energy particle bombardment and are deposited on a substrate, i.e. the base layer or body 18, as a thin film.

**[0036]** The decorative radome 10 according to the present invention can further include a transparent resin layer 22 which overlies the decoration layer 20 for adapting the complete body to the mill metric wave semi wave length resulting in a lower attenuation for the radar waves.

The resin layer 22 may be molded over the base body 18 and decoration layer 20 and may include, on its outer face, a decorative ink overlay complementing the ornamental appearance of the decoration layer 20.

5 **[0037]** The base layer or body 18 is composed of a material that provides low radio transmission loss and is superior in terms of dielectric properties. Relative permittivity  $E'$  and dielectric loss  $\tan \theta$ , for example, provide an indication of the dielectric property.

10 **[0038]** As previously mentioned, the radar antenna 16 is mounted in an automobile 14 and disposed behind the front grill assembly 12. The decorative radome 10, which includes a bright metallic emblem of an automobile manufacturer or a specific decoration, is disposed within the front grill assembly 12.

15 **[0039]** With reference to FIG. 2, it will be observed that millimeter waves 23 from the radar device 16 are radiated forward through the radome 10 and reflection waves 24 from an object 26 return to the radar device 16 through the radome 10.

20 **[0040]** The decoration layer 20 may comprise germanium and/or a germanium alloy with the germanium alloy comprising germanium alloyed with one or more elements selected from the metalloids group in the periodic table, such as silicon.

25 **[0041]** The decorative layer 20 may be formed of a plurality of germanium and/or germanium alloy strata or alternating strata of germanium and germanium alloy with each strata having a thickness in the order of 1 nm to 500 nm, with a thickness of each strata in the order of 10  $\mu\text{m}$  to 100 nm believed to be the most efficient in achieving the objectives of the present invention and for obtaining metallic color effects.

30 **[0042]** Further the decorative layer may comprise alternating strata of germanium and/or germanium alloy and strata of another metalloid, such as silicon, also applied by sputtering deposition.

35 **[0043]** Thus it will be seen that there is provided an decorative radome for automotive vehicular applications which achieves the various aspects, features and considerations of the present invention and which is well suited to meet the conditions of practical usage.

#### 45 **Claims**

1. A decorative radome (10) comprising a substrate (18) formed of a radio transmissive resin, the substrate (18) having a proximal face and a distal face and a decoration layer (20) applied to the proximal face, **characterized in that** the decoration layer (20) is composed of boron, silicon, germanium, arsenic, antimony and/or tellurium or an alloy composed of boron, silicon, germanium, arsenic, antimony or tellurium deposited on the surface of the proximal face.
2. A decorative radome (10) as constructed in accordance with claim 1 wherein the decoration layer (20)

- is of uniform thickness.
3. A decorative radome (10) as constructed in accordance with claim 1 wherein the substrate is molded.
  4. A decorative radome (10) as constructed in accordance with claim 1 wherein the decoration layer (20) is formed of a plurality of boron, silicon, germanium, arsenic, antimony or tellurium or boron, silicon, germanium, arsenic, antimony or tellurium alloy layers.
  5. A decorative radome (10) as constructed in accordance with claim 4 wherein the thickness of each boron, silicon, germanium, arsenic, antimony or tellurium or boron, silicon, germanium, arsenic, antimony or tellurium alloy layer is in the order of 1 nm to 500 nm.
  6. A decorative radome (10) as constructed in accordance with claim 4 wherein the thickness of each boron, silicon, germanium, arsenic, antimony or tellurium or boron, silicon, germanium, arsenic, antimony or tellurium alloy layer is in the order of 10 nm to 100 nm.
  7. A decorative radome (10) as constructed in accordance with claim 4 wherein one of the layers comprises germanium and another layer comprises silicon.
  8. A decorative radome (10) as constructed in accordance with claim 1 further including a radio transmissive resin layer (22) overlying the decoration layer (20).
  9. A decorative radome (10) as constructed in accordance with claim 8 wherein the resin layer (22) is molded over the decoration layer (20).
  10. A decorative radome (10) as constructed in accordance with claim 9 wherein the resin layer (22) includes a decoration ink overlay.
  11. A decorative radome (10) as constructed in accordance with claim 1 wherein the proximal face of the substrate (18) is configured with a design comprising surface indentations or projections.
  12. A decorative radome (10) as constructed in accordance with claim 1 wherein boron, silicon, germanium, arsenic, antimony and/or tellurium or an alloy composed of boron, silicon, germanium, arsenic, antimony or tellurium is deposited on the surface of the proximal face by sputtering deposition.
  13. A method of fabricating a decorative radome (10), the method comprising the steps of:
    - a) providing a substrate (18) comprising a resin layer (22) having a proximal face and a distal face:
      - b) covering the proximal face with a decoration layer (20) composed of boron, silicon, germanium, arsenic, antimony or tellurium or an alloy composed of boron, silicon, germanium, arsenic, antimony or tellurium utilizing sputtering deposition; and
      - c) covering the decoration layer (20) with a further resin layer.
  14. A method of fabricating a decorative radome (10) in accordance with claim 13 wherein the substrate resin layer and the further resin layer are formed by molding.
  15. A method of fabricating a decorative radome (10) in accordance with claim 13 wherein step a) includes configuring the proximal face with surface indentations or depressions.
  16. A method of fabricating a decorative radome (10) in accordance with claim 13 wherein the decoration layer (20) comprises germanium and/or a germanium alloy.
  17. Vehicle (14) including a decorative radome (10) in accordance with anyone of claims 1-12 including a front grill assembly (12), the decoration radome (10) being positioned within the grill assembly (12), the vehicle (14) further including a radar antenna (16) positioned behind and in registration with the decorative radome (10).

#### Patentansprüche

1. Dekoratives Radom (10), aufweisend ein Substrat (18), das aus einem für Funkwellen durchlässigen Harz gebildet ist, wobei das Substrat (18) eine proximale Fläche und eine distale Fläche und eine auf die proximale Fläche aufgebraute Dekorationsschicht (20) hat, **dadurch gekennzeichnet, dass** die Dekorationsschicht (20) aus Bor, Silizium, Germanium, Arsen, Antimon und/oder Tellur zusammengesetzt ist oder eine Legierung, die aus Bor, Silizium, Germanium, Arsen, Antimon oder Tellur zusammengesetzt ist, auf die Oberfläche der proximalen Fläche aufgebracht ist.
2. Dekoratives Radom (10) nach Anspruch 1, bei dem die Dekorationsschicht (20) eine gleichförmige Dicke hat.
3. Dekoratives Radom (10) nach Anspruch 1, bei dem das Substrat geformt ist.
4. Dekoratives Radom (10) nach Anspruch 1, bei dem

- die Dekorationsschicht (20) aus mehreren von Bor-, Silizium-, Germanium-, Arsen-, Antimon- oder Tellurschichten, oder Bor-, Silizium-, Germanium-, Arsen-, Antimon- oder Tellurlegierungs-Schichten gebildet ist.
- 5
5. Dekoratives Radom (10) nach Anspruch 4, bei dem die Dicke jeder Bor-, Silizium-, Germanium-, Arsen-, Antimon- oder Tellurschicht, oder Bor-, Silizium-, Germanium-, Arsen-, Antimon- oder Tellurlegierungs-Schicht in dem Bereich von 1 nm bis 500 nm ist.
- 10
6. Dekoratives Radom (10) nach Anspruch 4, bei dem die Dicke jeder Bor-, Silizium-, Germanium-, Arsen-, Antimon- oder Tellurschicht, oder Bor-, Silizium-, Germanium-, Arsen-, Antimon- oder Tellurlegierungs-Schicht in dem Bereich von 10 nm bis 100 nm ist.
- 15
7. Dekoratives Radom (10) nach Anspruch 4, bei dem eine der Schichten Germanium aufweist und eine andere Schicht Silizium aufweist.
- 20
8. Dekoratives Radom (10) nach Anspruch 1, weiterhin enthaltend eine für Funkwellen durchlässige Harzschicht (22), die über der Dekorationsschicht (20) liegt.
- 25
9. Dekoratives Radom (10) nach Anspruch 8, bei dem die Harzschicht (22) über der Dekorationsschicht (20) geformt ist.
- 30
10. Dekoratives Radom (10) nach Anspruch 9, bei dem die Harzschicht (22) einen Dekorationstinten-Überzug enthält.
- 35
11. Dekoratives Radom (10) nach Anspruch 1, bei dem die proximale Fläche des Substrats (18) mit einem Design konfiguriert ist, das Oberflächenvertiefungen oder-vorsprünge aufweist.
- 40
12. Dekoratives Radom (10) nach Anspruch 1, bei dem Bor, Silizium, Germanium, Arsen, Antimon und/oder Tellur oder eine Legierung, die aus Bor, Silizium, Germanium, Arsen, Antimon oder Tellur zusammengesetzt ist, auf die Oberfläche der proximalen Fläche durch Sputteraufbringung aufgebracht sind.
- 45
13. Verfahren zum Herstellen eines dekorativen Radoms (10), welches Verfahren die Schritte aufweist:
- 50
- a) Bereitstellen eines Substrats (18), das eine Harzschicht (22) mit einer proximalen Fläche und einer distalen Fläche aufweist;
- 55
- b) Bedecken der proximalen Fläche mit einer Dekorationsschicht (20), die aus Bor, Silizium, Germanium, Arsen, Antimon oder Tellur zusammengesetzt ist, oder einer Legierung, die aus Bor, Silizium, Germanium, Arsen, Antimon oder Tellur zusammengesetzt ist, unter Verwendung einer Sputteraufbringung; und
- c) Bedecken der Dekorationsschicht (20) mit einer weiteren Harzschicht.
14. Verfahren zum Herstellen eines dekorativen Radoms (10) nach Anspruch 13, bei dem die Harzschicht des Substrats und die weitere Harzschicht durch Formen gebildet werden.
15. Verfahren zum Herstellen eines dekorativen Radoms (10) nach Anspruch 13, bei dem Schritt a) das Konfigurieren der proximalen Fläche mit Oberflächenvertiefungen oder-vorsprünge enthält.
16. Verfahren zum Herstellen eines dekorativen Radoms (10) nach Anspruch 13, bei dem die Dekorationsschicht (20) Germanium und/oder eine Germaniumlegierung aufweist.
17. Fahrzeug (14) enthaltend ein dekoratives Radom (10) nach einem der Ansprüche 1 bis 12, enthaltend eine Frontgrillanordnung (12), wobei das dekorative Radom (10) innerhalb der Grillanordnung (12) positioniert ist, welches Fahrzeug (14) weiterhin eine Radarantenne (16) enthält, die hinter und in Ausrichtung mit dem dekorativen Radom (10) positioniert ist.

#### Revendications

1. Radôme décoratif (10) comprenant un substrat (18) formé d'une résine radiotransmetteuse, le substrat (18) ayant une face proximale et une face distale et une couche de décoration (20) appliquée à la face proximale, **caractérisé en ce que** la couche de décoration (20) est composée de bore, de silicium, de germanium, d'arsenic, d'antimoine et/ou de tellure et d'un alliage composé de bore, de silicium, de germanium, d'arsenic, d'antimoine ou de tellure déposé sur la surface de la face proximale.
2. Radôme décoratif (10) tel que construit selon la revendication 1, dans lequel la couche de décoration (20) est d'épaisseur uniforme.
3. Radôme décoratif (10) tel que construit selon la revendication 1, dans lequel le substrat est moulé.
4. Radôme décoratif (10) tel que construit selon la revendication 1, dans lequel la couche de décoration (20) est formée d'une pluralité de couches de bore, de silicium, de germanium, d'arsenic, d'antimoine ou de tellure ou d'alliage de bore, de silicium, de germanium, d'arsenic, d'antimoine ou de tellure.

5. Radôme décoratif (10) tel que construit selon la revendication 4, dans lequel l'épaisseur de chaque couche de bore, de silicium, de germanium, d'arsenic, d'antimoine ou de tellure ou d'alliage de bore, de silicium, de germanium, d'arsenic, d'antimoine ou de tellure est de l'ordre de 1 nm à 500 nm. 5
6. Radôme décoratif (10) tel que construit selon la revendication 4, dans lequel l'épaisseur de chaque couche de bore, de silicium, de germanium, d'arsenic, d'antimoine ou de tellure ou d'alliage de bore, de silicium, de germanium, d'arsenic, d'antimoine ou de tellure est de l'ordre de 10 nm à 100 nm. 10
7. Radôme décoratif (10) tel que construit selon la revendication 4, dans lequel l'une des couches comprend du germanium et une autre couche comprend du silicium. 15
8. Radôme décoratif (10) tel que construit selon la revendication 1, incluant en outre une couche de résine radiotransmetteuse (22) recouvrant la couche de décoration (20). 20
9. Radôme décoratif (10) tel que construit selon la revendication 8, dans lequel la couche de résine (22) est moulée par-dessus la couche de décoration (20). 25
10. Radôme décoratif (10) tel que construit selon la revendication 9, dans lequel la couche de résine (22) inclut une incrustation d'encre de décoration. 30
11. Radôme décoratif (10) tel que construit selon la revendication 1, dans lequel la face proximale du substrat (18) est configurée avec une conception comprenant des indentations ou saillies de surface. 35
12. Radôme décoratif (10) tel que construit selon la revendication 1, dans lequel le bore, le silicium, le germanium, l'arsenic, l'antimoine et/ou le tellure ou un alliage composé de bore, de silicium, de germanium, d'arsenic, d'antimoine ou de tellure sont déposés sur la surface de la face proximale par dépôt par pulvérisation cathodique. 40
13. Procédé de fabrication d'un radôme décoratif (10), le procédé comprenant les étapes de : 45
- a) fourniture d'un substrat (18) comprenant une couche de résine (22) ayant une face proximale et une face distale ; 50
- b) couverture de la face proximale avec une couche de décoration (20) composée de bore, de silicium, de germanium, d'arsenic, d'antimoine ou de tellure ou d'un alliage composé de bore, de silicium, de germanium, d'arsenic, d'antimoine ou de tellure en employant un dépôt par pulvérisation ; et 55
- c) couverture de la couche de décoration (20) avec une couche de résine supplémentaire.
14. Procédé de fabrication d'un radôme décoratif (10) selon la revendication 13, dans lequel la couche de résine de substrat et la couche de résine supplémentaire sont formées par moulage.
15. Procédé de fabrication d'un radôme décoratif (10) selon la revendication 13, dans lequel l'étape a) inclut la configuration de la face proximale avec des indentations ou dépressions de surface.
16. Procédé de fabrication d'un radôme décoratif (10) selon la revendication 13, dans lequel la couche de décoration (20) comprend du germanium et/ou un alliage de germanium.
17. Véhicule (14) incluant un radôme décoratif (10) selon l'une quelconque des revendications 1 à 12, incluant un ensemble calandre avant (12), le radôme décoratif (10) étant positionné dans l'ensemble calandre (12), le véhicule (14) incluant en outre une antenne radar (16) positionnée derrière et en alignement avec le radôme décoratif (10).

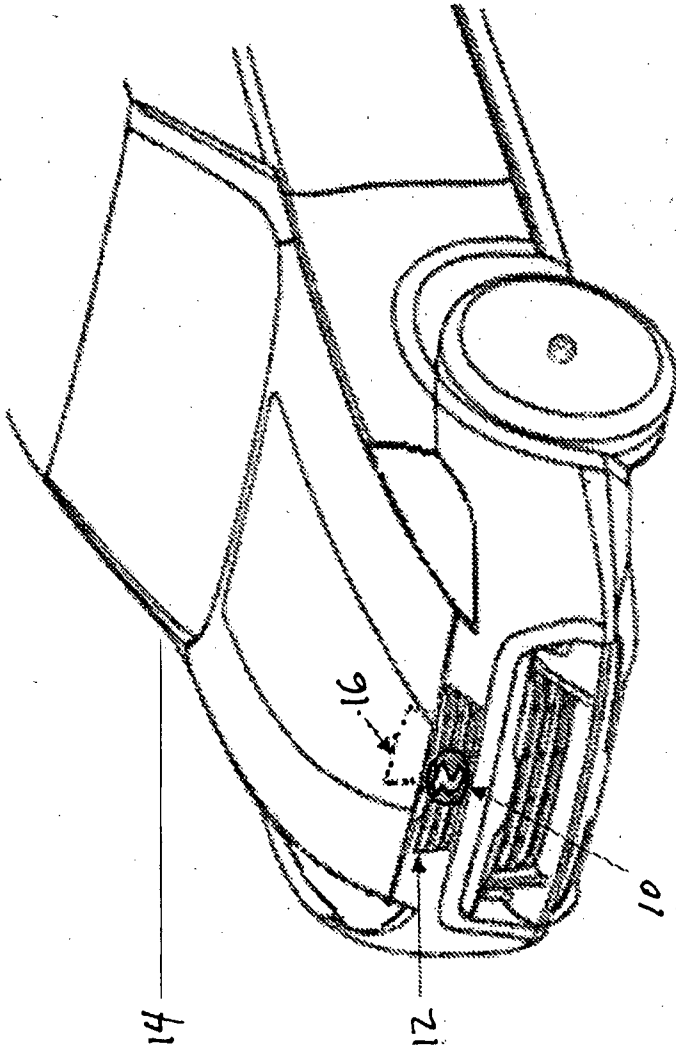

**Fig. 1**

Fig. 2

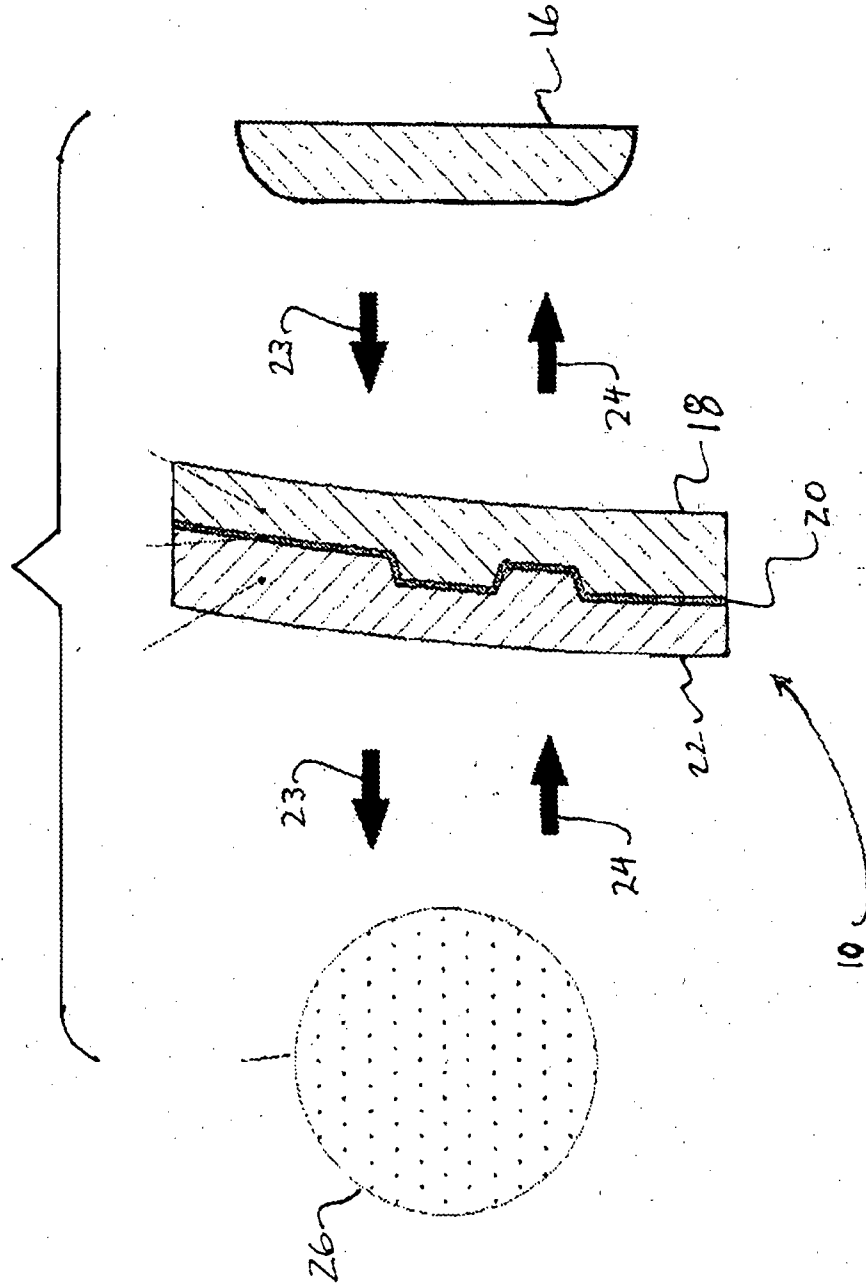

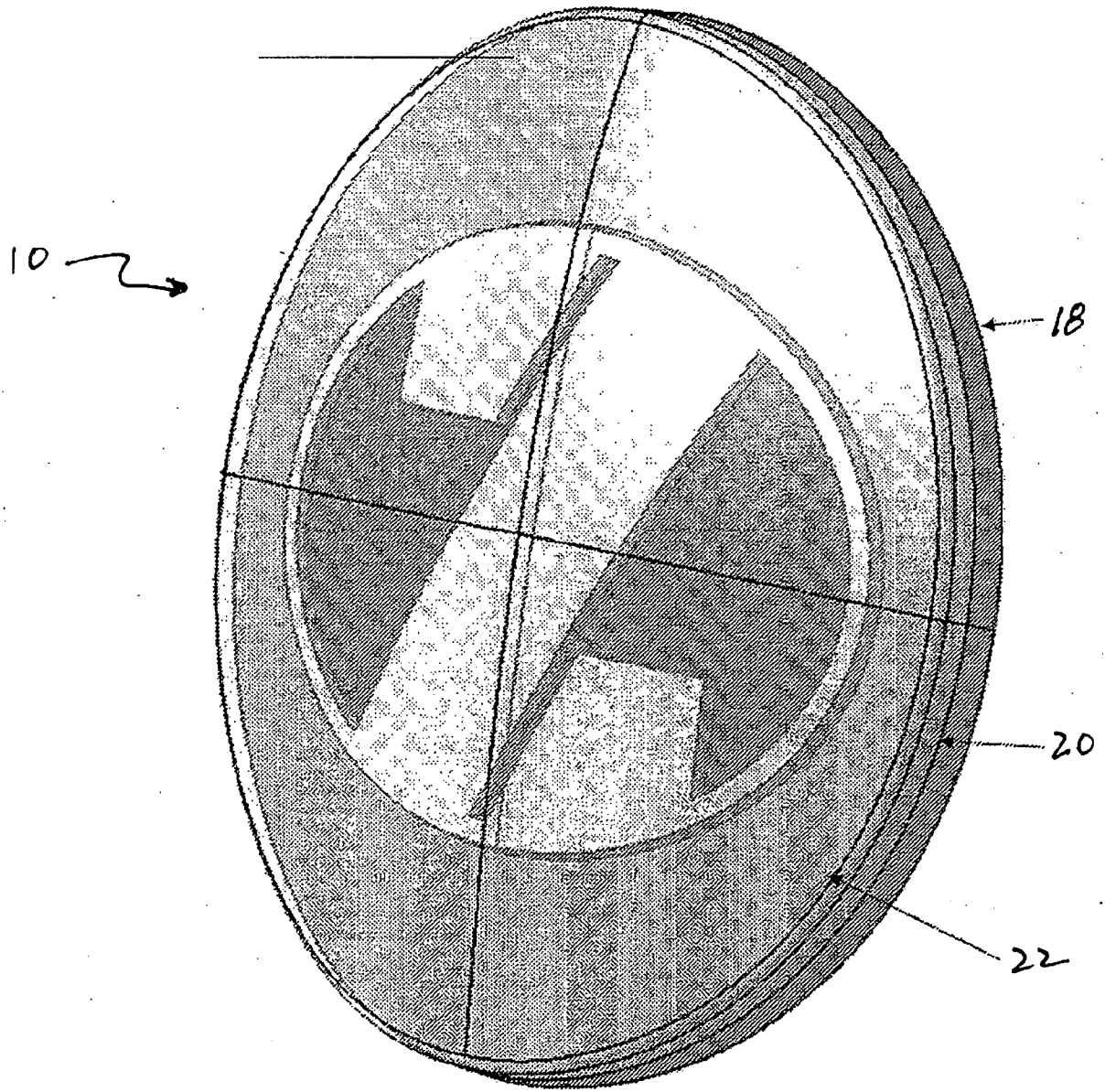

**Fig. 3**

**REFERENCES CITED IN THE DESCRIPTION**

*This list of references cited by the applicant is for the reader's convenience only. It does not form part of the European patent document. Even though great care has been taken in compiling the references, errors or omissions cannot be excluded and the EPO disclaims all liability in this regard.*

**Patent documents cited in the description**

- US 6328358 B [0005] [0009]
- WO 2010084733 A1 [0012]
- EP 1560288 A2 [0028]
- JP 2003252137 A [0031]

## DEKORATÍV RADARANTENNA-BURKOLAT GÉPJÁRMŰ-TECHNIKAI ALKALMAZÁSRA

### SZABADALMI IGÉNYPONTOK

Dekoratív radarantenna-burkolat (10), amely magában foglal egy rádióhullám-áteresztő gyantából kialakított hordozót (18), amely hordozónak (18) van egy proximális oldala és egy disztális oldala, és a proximális oldalra fel van hordva egy díszítő réteg (20), azzal jellemezve, hogy a díszítő réteget (20) bór, szilícium, germánium, arzén, antimon és/vagy tellúr, vagy egy, a proximális oldal felületére felvitt, bőrből, szilíciumból, germániumból, arzénből, antimonból vagy tellúrból álló ötvözet képezi.

2. Az 1. igénypont szerint összeállított dekoratív radarantenna-burkolat (10), amelyben a díszítő réteg (20) egyenletes vastagságú.

3. Az 1. igénypont szerint összeállított dekoratív radarantenna-burkolat (10), amelyben a hordozó sajtolással készül.

4. Az 1. igénypont szerint összeállított dekoratív radarantenna-burkolat (10), amelyben a díszítő réteg (20) több, bór-, szilícium-, germánium-, arzén-, antimon- vagy tellúr-rétegből vagy bór-, szilícium-, germánium-, arzén-, antimon- vagy tellúr-ötvözetből álló rétegből van kialakítva.

5. A 4. igénypont szerint összeállított dekoratív radarantenna-burkolat (10), amelyben valamennyi bór-, szilícium-, germánium-, arzén-, antimon- vagy tellúr-réteg vagy bór-, szilícium-, germánium-, arzén-, antimon- vagy tellúr-ötvözetből álló réteg vastagsága 1 nm és 500 nm között van.

6. A 4. igénypont szerint összeállított dekoratív radarantenna-burkolat (10), amelyben valamennyi bór-, szilícium-, germánium-, arzén-, antimon- vagy tellúr-réteg vagy bór-, szilícium-, germánium-, arzén-, antimon- vagy tellúr-ötvözetből álló réteg vastagsága 10 nm és 100 nm között van.

7. A 4. igénypont szerint összeállított dekoratív radarantenna-burkolat (10), amelyben az egyik réteg germániumot, egy másik réteg pedig szilíciumot foglal magában.

8. Az 1. igénypont szerint összeállított dekoratív radarantenna-burkolat (10), amely magában foglal továbbá egy, a díszítő réteg (20) felett lévő, rádióhullám-áteresztő gyantaréteget (22).

9. A 8. igénypont szerint összeállított dekoratív radarantenna-burkolat (10), amelyben a gyantaréteg (22) rá van sajtolva a díszítő rétegre (20).

10. A 9. igénypont szerint összeállított dekoratív radarantenna-burkolat (10), amelyben a gyanta-réteg (22) magában foglal egy díszítőfesték-bevonatot.

11. Az 1. igénypont szerint összeállított dekoratív radarantenna-burkolat (10), amelyben a hordozó (18) proximális oldala felületi bemélyedéseket vagy kiemelkedéseket tartalmazó dizájnnal van kialakítva.

12. Az 1. igénypont szerint összeállított dekoratív radarantenna-burkolat (10), amelyben katódporlasztással bór, szilícium, germánium, arzén, antimon és/vagy tellúr, vagy bórból, szilíciumból, germániumból, arzénből, antimonból vagy tellúrból álló ötvözet kerül felvitelre a proximális oldal felületére.

13. Eljárás dekoratív radarantenna-burkolat (10) gyártására, amely eljárás a következő lépéseket tartalmazza:

a) rendelkezésre bocsátunk egy gyantaréteget (22) tartalmazó hordozót (18), amelynek van egy proximális oldala és egy disztális oldala;

b) katódporlasztás alkalmazásával bevonjuk a proximális oldalt egy díszítő réteggel (20), amelyet bór, szilícium, germánium, arzén, antimon vagy tellúr, vagy egy bórból, szilíciumból, germániumból, arzénből, antimonból vagy tellúrból álló ötvözet alkot; és

c) bevonjuk a díszítő réteget (20) egy további gyantaréteggel.

14. A 13. igénypont szerinti eljárás dekoratív radarantenna-burkolat (10) gyártására, amelyben a hordozó gyantaréteget és a további gyantaréteget sajtolással alakítjuk ki.

15. A 13. igénypont szerinti eljárás dekoratív radarantenna-burkolat (10) gyártására, amelyben az a) lépés magában foglalja, hogy a proximális oldalt felületi bemélyedésekkel vagy kiemelkedésekkel alakítjuk ki.

16. A 13. igénypont szerinti eljárás dekoratív radarantenna-burkolat (10) gyártására, amelyben a díszítő réteg (20) germániumot és/vagy germánium-ötvözetet tartalmaz.

17. Jármű (14), amely magában foglal egy, az 1-12. igénypontok bármelyike szerinti dekoratív radarantenna-burkolatot (10) beleértve egy elülső hűtőrács szerelvényt (12), amely dekoratív radarantenna-burkolat (10) a hűtőrács szerelvényen (12) belül van elhelyezve, a jármű (14) magában foglal továbbá egy radarantennát (16), amely a dekoratív radarantenna-burkolat (10) mögött és ahhoz hozzáigazítva van elhelyezve.

(A meghatalmazott)

Hegyesvári Donácz Katalin  
Központi Irodák Igazgatója  
Központi Irodák Igazgatói Iroda  
Budapest, Magyarországi Köztársaság  
1133 Budapest, Magyarországi Köztársaság  
1133 Budapest, Magyarországi Köztársaság  
1133 Budapest, Magyarországi Köztársaság