

No. 730,446.

PATENTED JUNE 9, 1903.

E. J. FAIN.
SEWING MACHINE ATTACHMENT.
APPLICATION FILED JUNE 13, 1902.

NO MODEL.

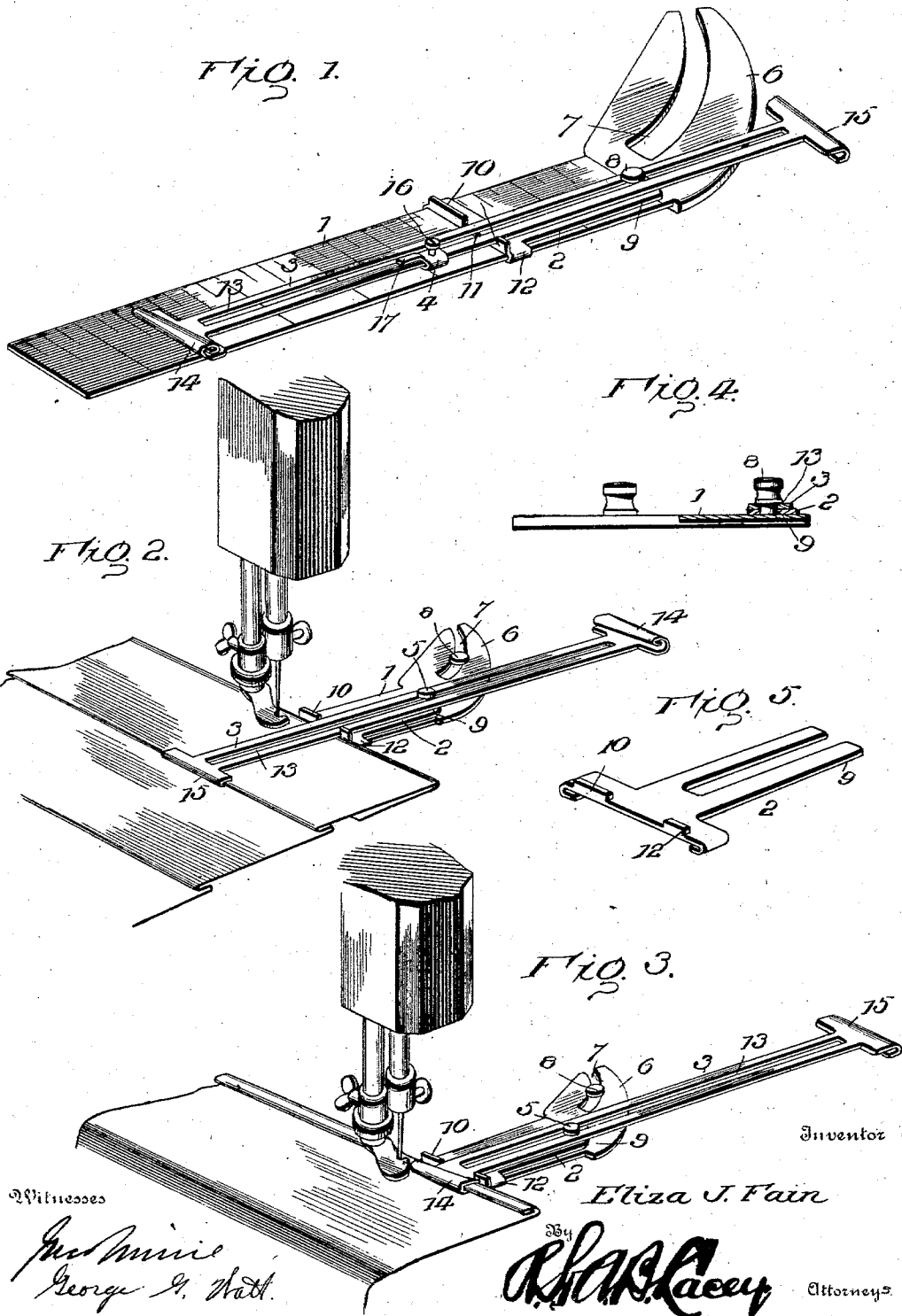

UNITED STATES PATENT OFFICE.

ELIZA JANE FAIN, OF WHITEWRIGHT, TEXAS.

SEWING-MACHINE ATTACHMENT.

SPECIFICATION forming part of Letters Patent No. 730,446, dated June 9, 1903.

Application filed June 13, 1902. Serial No. 111,532. (No model.)

To all whom it may concern:

Be it known that I, ELIZA JANE FAIN, a citizen of the United States, residing at White-
wright, in the county of Grayson and State
5 of Texas, have invented certain new and use-
ful Improvements in Sewing-Machine At-
tachments, of which the following is a speci-
fication.

This invention aims to provide an attach-
10 ment for use in connection with any sewing-
machine combining means for hemming,
tucking, and braiding, the several parts be-
ing adjustable to admit of making hems any
width and tucks any size and distance apart,
15 the device being simple and comprising a
minimum number of parts.

For a full description of the invention and
the merits thereof and also to acquire a knowl-
edge of the details of construction of the
20 means for effecting the result reference is to
be had to the following description and draw-
ings hereto attached.

While the essential and characteristic fea-
25 tures of the invention are susceptible of modi-
fication, still the preferred embodiment of
the invention is illustrated in the accompa-
nying drawings, in which—

Figure 1 is a perspective view of the at-
tachment. Fig. 2 is a perspective view show-
30 ing the manner of using the attachment for
tucking. Fig. 3 is a perspective view show-
ing the manner of using the attachment for
hemming. Fig. 4 is a transverse section of
the attachment in front of the gage. Fig. 5
35 is a perspective view of the gage.

The device comprises, essentially, five
parts—the base-plate 1, gage 2, slide 3, braider
4, and clamp-screw 5 for securing the slide
and gage to the plate 1 in the required ad-
40 justed position. The plate 1 is graduated to
admit of the depth of tuck or hem or the
space between the tucks being readily deter-
mined. One end of the plate is curved, as
shown at 6, and is provided with a curved
45 slot 7 to receive the clamp-screw 8, by means
of which the plate 1 is secured to the bed of
the sewing-machine head in the required po-
sition. The curved slot 7 admits of adjust-
ment of the plate with reference to the sew-
50 ing-machine needle and presser-foot, accord-
ing to the nature of the work and the kind
of goods to be stitched.

The gage 2 comprises a slotted stem 9 and
the stop 10, which is arranged at a right angle
to the stem 9 and comprises right-angularly- 55
disposed wings, one of the wings resting on
the plate 1 and the other wing projected at
a right angle thereto and provided with a
notch or cut-away portion 11 for the reception
of the slide 3. The ends of the wing resting 60
on the plate are bent so as to embrace the
edges of the plate 1, as shown at 12, thereby
holding the stop to the plate. The clamp-
screw 5 passes through the slot of the stem 9,
so as to hold the gage in an adjusted position. 65

The slide 3 comprises a bar having a slot
13, through which the clamp-screw 5 passes,
so as to hold the slide in an adjusted posi-
tion. A hemmer 14, of ordinary construc-
tion, is provided at one end of the slide 3, and 70
a stop 15 is provided at the opposite end of
the slide and constitutes a tuck-spacer and
consists of a metal strip folded so as to em-
brace the edge of the tuck or the hem. For
75 tucking the stop 15 is faced downward to ad-
mit of a space between the plate 1 and slide
3; but for hemming the stop 15 is faced up-
ward to admit of the slide 3 resting on the
plate 1, and in this position the goods pass
80 over the slide.

The braider 4 comprises a clamp 16 and a
finger or projection 17, offset from a member
of the clamp, so as to provide a space be-
tween it and the slide, to which the braider
is attached. 85

Fig. 2 shows the attachment adapted for
tucking, the tuck being stitched having its
edge in contact with the gage 2 and the tuck
previously finished being in engagement with
the stop 15. A movement of the gage 2 upon 90
the plate 1 determines the depth or width of
the tuck, whereas an adjustment of the slide
3 determines the distance between the tucks,
whereby they may be spaced apart a greater
or less distance, according as required. When 95
the attachment is used for hemming, the slide
is turned so as to bring the hemmer 14 in po-
sition to turn the edge of the goods. The
depth or width of the hem is controlled by
the gage 2. The gage and slide are secured 100
to the base-plate by the same clamp-screw 5
and are loosened or made fast by a single de-
vice, thereby simplifying the construction and
operation.

Having thus described the invention, what is claimed as new is—

In a sewing-machine attachment, a plate, a gage applied to the plate and comprising a stem having a slot extended therein from one end, a stop at the opposite end of the stem extended upward therefrom and cut away intermediate of its ends at its top edge, and lateral extensions adjacent to the stop and bent to embrace opposite edges of the plate, a longitudinally-slotted slide fitted in the said cut-away portion of the stop and having op-

posite working ends, and a clamp-screw passed through the slots of the stem and slide for securing the gage and slide to the plate in independent relative adjusted positions, substantially as specified.

In testimony whereof I affix my signature in presence of two witnesses.

ELIZA JANE FAIN. [L. S.]

Witnesses:

HARRY McELRATH,
JOE McGAUGHY.