

W. D. WANSBROUGH.
VARIABLE SPROCKET GEAR.

(Application filed Feb. 18, 1902.)

(No Model.)

4 Sheets—Sheet 1.

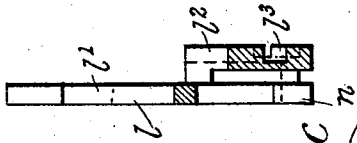

FIG. 2-

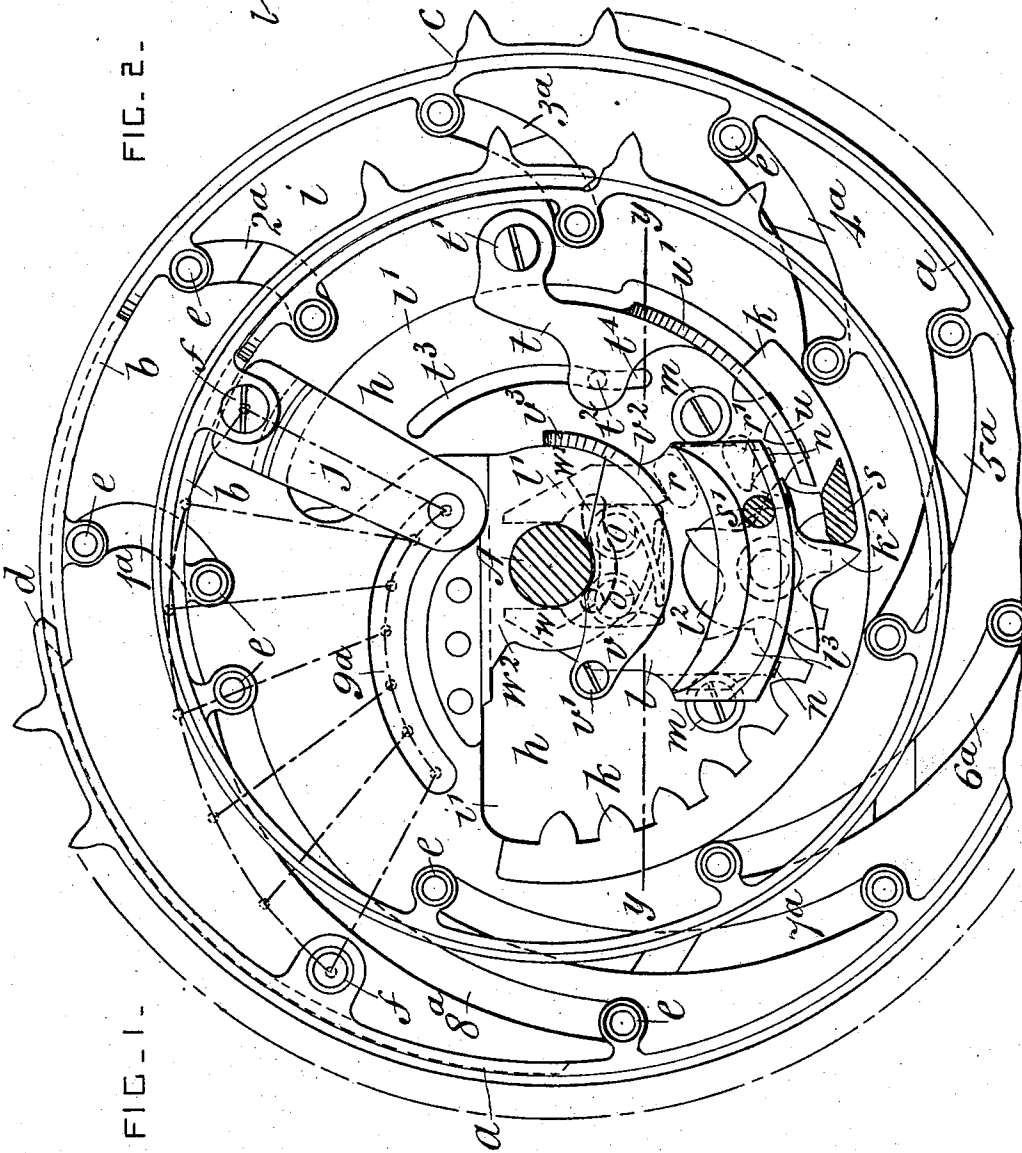

FIG. 1-

Witnesses:
R. D. Young
James M. Spear

Inventor
Wm. D. Wansbrough
 by *Herbert W. Jenner*
 Attorney

W. D. WANSBROUGH.
VARIABLE SPROCKET GEAR.

(Application filed Feb. 18, 1902.)

(No Model.)

4 Sheets—Sheet 2.

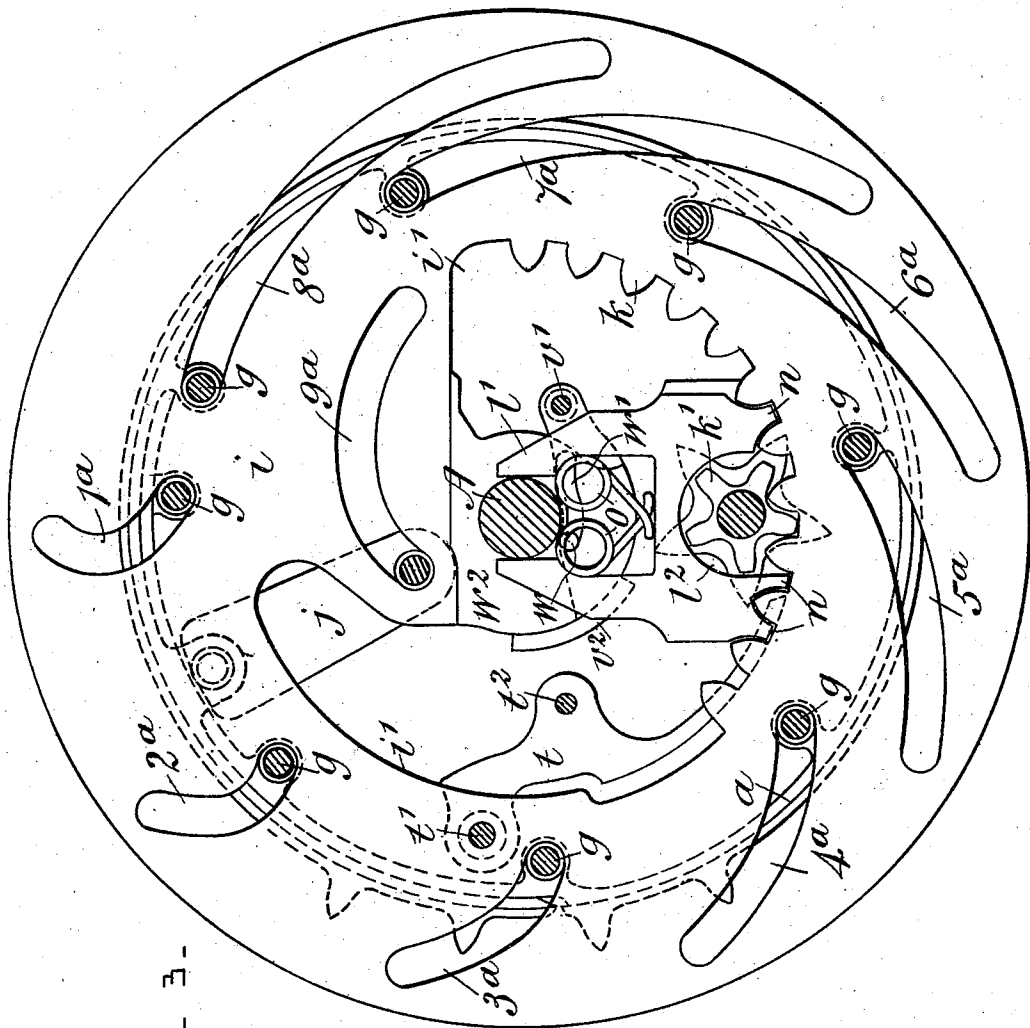

FIG. 3-

Witnesses:

R. H. Young
James M. Spear

Inventor.

Wm. D. Wansbrough.
 by *Herbert W. Jenner.*
 Attorney.

W. D. WANSBROUGH.
VARIABLE SPROCKET GEAR.

(Application filed Feb. 18, 1902.)

(No Model.)

4 Sheets—Sheet 3.

FIG. 4.

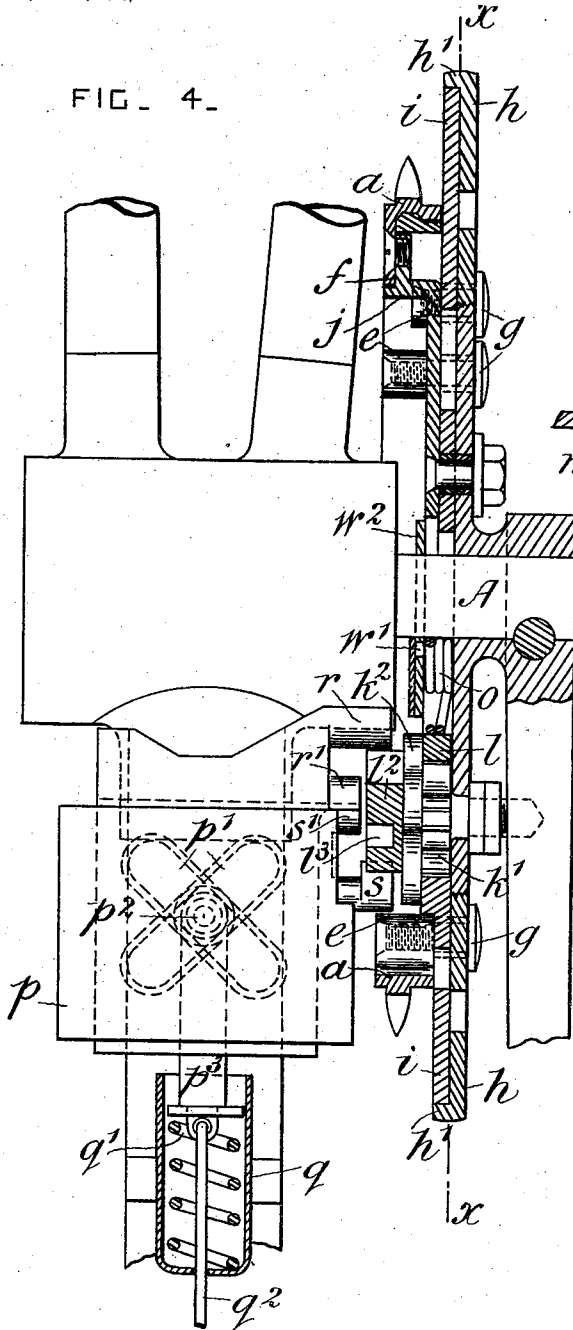

FIG. 5.

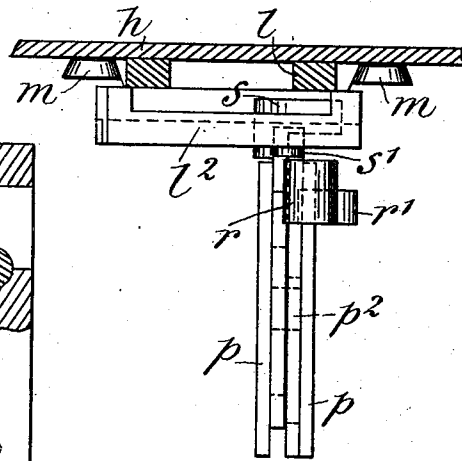
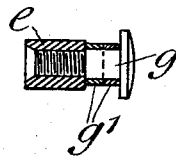

FIG. 6.



Witnesses:

R. H. Young
James M. Spear

Inventor:

Wm. D. Wansbrough
by *Herbert W. Jenner*
Attorney.

W. D. WANSBROUGH.
VARIABLE SPROCKET GEAR.

(Application filed Feb. 18, 1902.)

(No Model.)

4 Sheets—Sheet 4.

Fig. 7.

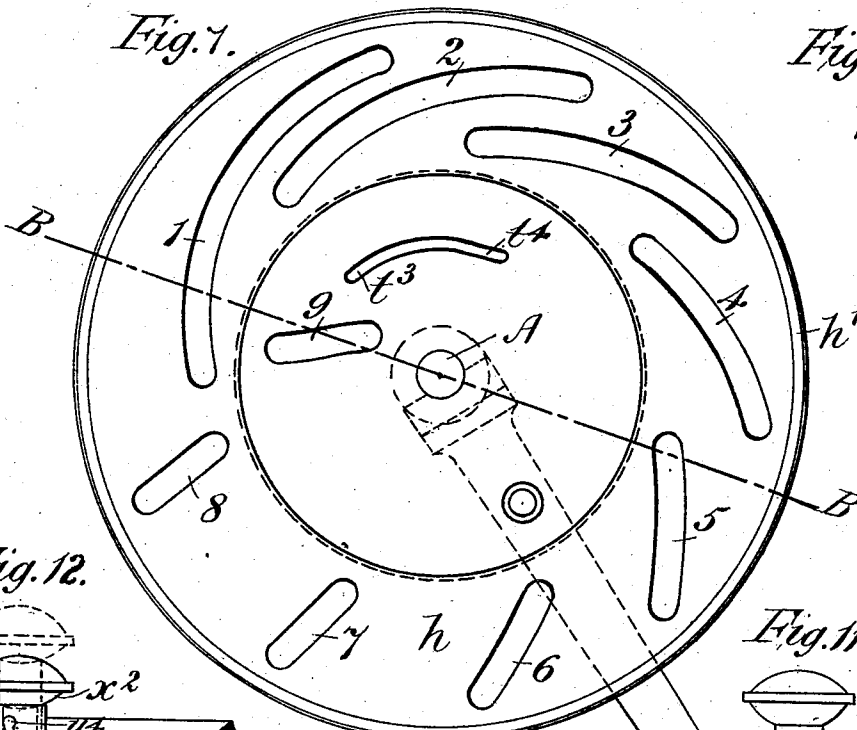

Fig. 8.

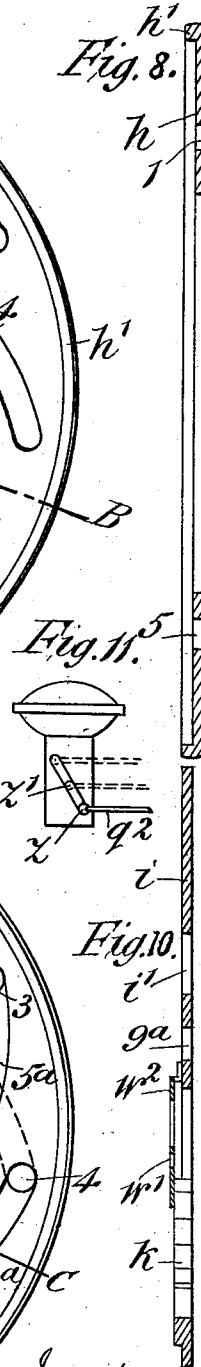

Fig. 12.

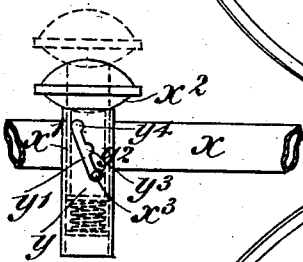

Fig. 11.

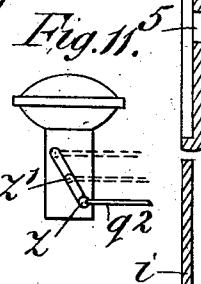

Fig. 9.

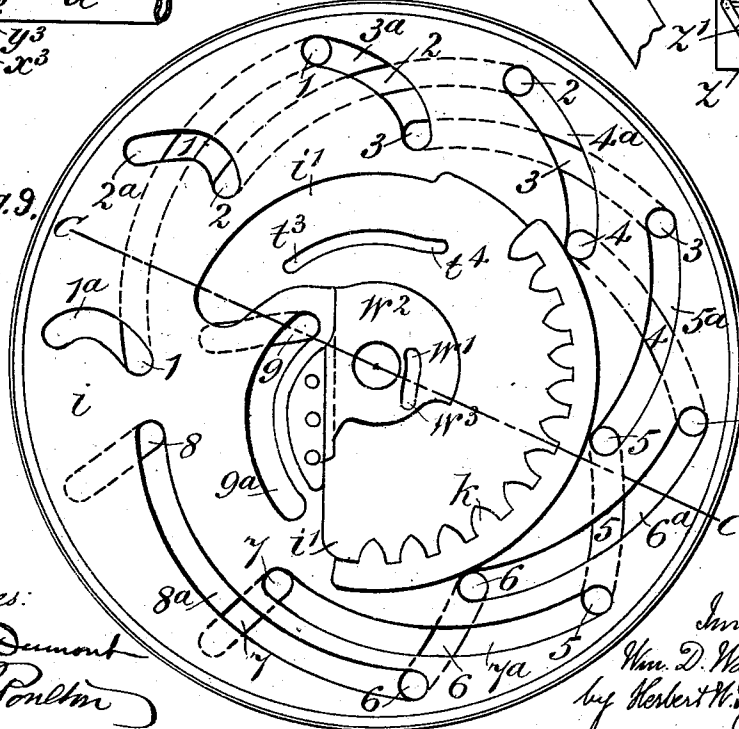

Fig. 10.



Witnesses:

E. C. Dumont
Geo. C. Boulton

Inventor.

Wm. D. Wansbrough.
by Herbert W. Jenner.
Attorney.

UNITED STATES PATENT OFFICE.

WILLIAM DYSON WANSBROUGH, OF LINCOLN, ENGLAND.

VARIABLE SPROCKET-GEAR.

SPECIFICATION forming part of Letters Patent No. 712,985, dated November 4, 1902.

Application filed February 18, 1902, Serial No. 94,624. (No model.)

To all whom it may concern:

Be it known that I, WILLIAM DYSON WANSBROUGH, a subject of the King of Great Britain and Ireland, residing at Spring Hill House, Lincoln, in the county of Lincoln, England, have invented certain new and useful Improvements in Variable Sprocket-Gears; and I do hereby declare the following to be a full, clear, and exact description of the invention, such as will enable others skilled in the art to which it appertains to make and use the same.

This invention relates to a new or improved multiple-speed gear-wheel of the kind wherein a flexible divided chain-ring having overlapping extremities is expanded or contracted while carried against a circular plate, so as to provide a higher or lower gear, the object of the present invention being more particularly to provide new or improved means for expanding and contracting the chain ring and of such a nature that it is rigidly held at all points from its minimum to its maximum diameter, and vice versa, and in this manner to provide several different gears from the highest to the lowest corresponding to the different diameters in which the chain-ring is employed.

In order that this invention may be more fully understood, I will now proceed to describe same with reference to the accompanying drawings, in which—

Figure 1 is a diagrammatic side view of a chain-wheel constructed according to this invention. Fig. 2 is a detail vertical section through the locking-plate *l*, shown in Fig. 1. Fig. 3 is a partial section taken on line *xx* in Fig. 4. Fig. 4 is a sectional plan view of the chain-wheel from below. Fig. 5 is a section taken on line *yy* in Fig. 1. Fig. 6 is a detail view of one of the pins *s*. Fig. 7 is a detail side view of the outer plate, and Fig. 8 is a section taken on line *BB* in Fig. 7. Fig. 9 is a detail side view of the inner plate, and Fig. 10 is a section taken on the line *CC* in Fig. 9. Figs. 11 and 12 are detail views of the means for operating the sliding plates.

In carrying this invention into practical effect and as shown in the drawings I provide a gear-wheel capable of being employed for giving seven different gears and consisting of

a flexible divided chain-ring *a*, formed with teeth in the usual manner around the greater part of its circumference and having a plain reduced part *b* forming a bridge between the points *c* and *d* when the chain-ring is in the expanded position, but sliding under the part *d* when in the contracted position. The chain-ring is formed with eight lugs *e* and a ninth lug *f*, and through the eight lugs *e* studs *g* are passed, which are preferably screwed and riveted in place, and each stud carries two rollers *g'*. The chain-ring is carried against two superposed plates *h i*, formed with overlapping curved slots, the outer plate *h* being furnished with nine slots 1 to 9 and the inner plate *i* with nine slots 1^a to 9^a, which correspond to the nine points of attachment of the chain-ring. The outer plate *h* is formed in two parts secured together and with a flanged edge *h'*, and the inner plate *i* fits into the same, while the studs and rollers forming the connections of the chain-ring pass through and are contained within the slots of both plates, while the ninth slot in each plate if formed in the same manner as the first eight slots would intersect some of the said slots these ninth slots are formed more toward the center of the plates, as shown, and the ninth point of attachment of the chain-ring is connected with these slots by a connecting-arm *j*. In this manner it will be seen that by rotating the inner plate *i* over the outer plate *h* the combined action of the two sets of slots will force the chain-ring inward or outward, so as to expand or contract it, according to the direction in which the plate *i* is rotated, and for this purpose the plate *i* is formed with a toothed quadrant *k*, with which engages a toothed pinion or wheel *k'*, formed integrally with or secured to a star-wheel *k²*, which as the chain-wheel revolves may come into contact with a pin, either *r* or *s*, projecting from a fixed part of the frame of the machine, so that it, together with the pinion *k'*, may be turned one tooth at a time, so as to turn the inner plate *i* through the space of one tooth of the quadrant *k*, the star-wheel being operated either from the top or the bottom, according to the direction in which it is required to be revolved. The said star-wheel and pinion are provided with a shaft or spindle,

which is journaled in the plate h , as shown in Fig. 2.

The outer plate h and the inner plate i are normally locked together by a sliding locking-plate l , which is guided and secured between rollers m , carried by the outer plate h , and which is arranged in an opening or perforation i' in the inner plate. This sliding plate has a forked upper extremity l' sliding over the central axle A and at its lower extremity is furnished with teeth n , normally engaging the toothed quadrant k , in which position it is kept by the spring o , while the said plate is formed with a bridge-piece l^2 , 15 provided with a curved slot l^3 , as shown.

Before the inner plate i can be turned for altering the gear it is necessary for the locking-plate to be raised so as to free it from the toothed quadrant k , and for this purpose and also for turning the star-wheel I arrange within the casing p , close to the bottom bracket of the machine, two superposed sliding plates, each provided with a slot p' , which cross at right angles, as shown at Fig. 2, and through these slots a pin or roller p^2 works, which is connected with the sliding arm p^3 . The arm p^3 enters a cylindrical casing q and is normally retained in the forward position by a spring q' , but may be drawn within the cylindrical casing q through the medium of a suitable connection q^2 . In this manner by drawing forward the pin or stud p^2 or allowing it to be forced inward by the action of the spring q' one or other of the superposed sliding plates 30 may be forced toward the chain-wheel, or they may be both held in the intermediate position, as shown in the drawings. One of the superposed sliding plates is formed with a projecting pin r , designed to operate the star-wheel k^2 from the top, and also with a pin r' , designed to lift the locking-plate l , as hereinafter described, while the second sliding plate is provided with a projecting pin s , designed to operate the star-wheel k^2 from the bottom, 45 and with a pin s' for lifting the locking-plate l .

To expand the chain-ring, the sliding plate provided with the pins s s' is brought forward, so that as the chain-wheel passes the same the pin s' enters the curved slot l^3 in the bridge-piece l^2 of the locking-plate, lifts it out of engagement with the toothed quadrant k , and retains it in the raised position, while the star-wheel k^2 by striking against the pin s is turned 55 one tooth, thus operating the pinion k' and turning the quadrant k one tooth, when the pin s' passes out of the slot l^3 and the locking-plate again engages the toothed quadrant k and locks the two plates together for the remainder of the revolution. In a like manner for reducing the gear the plate provided with the pins r r' is brought forward, so that as the chain-wheel passes the same the pin r' enters the slot l^3 and raises the locking-plate, 60 while the star-wheel is operated from the top by the pin r , the pin r' then passing out

of the slot and allowing the locking-plate to again engage the toothed quadrant. In Fig. 1 these pins are diagrammatically shown in dotted lines.

In order that the plate carrying the pins s s' may be automatically forced back to allow the star-wheel to pass without being operated when the chain-ring is fully expanded, a curved plate t is pivoted to the inner plate i , as at t' , Fig. 1. This plate is formed with an upstanding edge u , having an inclined part u' running down to the face of the plate, while a pin t^2 projects into a slot t^3 , formed in the back plate h . The greater part of the slot t^3 is concentric with the center of the plate and in the first six positions of the chain-ring retains the plate in the raised position, as shown, so that the pin s in passing escapes the upstanding edge u ; but at the seventh position of the chain-ring, when it has reached its maximum diameter, the extremity t^4 of the slot t^3 forces the pin t^2 , and with it the plate t , outward from the center of the wheel, so that as the wheel revolves the inclined part u' of the upstanding edge u strikes the pin s and forces it and the sliding plate of which it is part back, so that the star-wheel passes in front of the pin and is not operated by it. In a like manner for preventing the star-wheel being operated after the chain-ring is fully contracted the plate v is pivoted, as at v' , to the back plate h and is formed with an upstanding edge v^2 , having a sloping or inclined extremity v^3 . This plate is operated by a pin w , engaging a slot w' , formed in a plate w^2 , riveted or suitably secured to the inner plate i , Figs. 1 and 5. The greater part of the slot w' is concentric with the center of the wheel and keeps the plate v in the raised position for the first six changes, so that as the wheel revolves the upstanding edge v^2 escapes the pin r in passing, which is then free to operate the star-wheel; but upon the seventh change being made when the chain-ring is fully contracted the extremity w^3 of the slot w' forces the pin w , and with it the pivoted plate v , outward from the center of the wheel, so that as the wheel revolves the inclined part v^3 of the upstanding edge v^2 comes into contact with the pin r and forces the latter and the plate of which it forms a part back and allows the star-wheel to pass without being operated.

The superposed sliding plates carrying the pins s s' and r r' are operated by drawing back the roller p^2 by means of the connection q^2 , as hereinbefore stated, and this may be effected by means of a conveniently-arranged hand-lever or in any other convenient and suitable manner, a convenient means to this end being shown in the detailed views Figs. 10 and 11. According to this arrangement with-in the top of the handle-bars x a tube x' , capable of a partially-rotary and vertical sliding movement, is arranged and furnished with a knob x^2 , by means of which it may be 130

revolved. In the outer tube y an inclined slot y' is formed, provided with three indents or catches $y^2 y^3 y^4$, while the inner tube x' is provided with a pin x^3 , passing through the slot y' and designed to engage in the notches $y^2 y^3 y^4$. The inner tube x' is provided with a projecting pin z , passing through a slot z' , formed in the tube y at right angles to the slot y' and to the pin z . The other extremity of the flexible connection q^2 is secured so that by revolving the inner tube x' by the knob x^2 the connection q^2 is drawn forward and may be secured in any one of the three positions indicated at $y^2 y^3 y^4$, which correspond with the three positions of the roller p^2 , operating the sliding plates—that is to say, with the roller p^2 fully forward and under the action of the spring q' in the central position and fully back.

Having now described my invention, what I claim as new, and desire to secure by Letters Patent, is—

1. In an expansible wheel, the combination, with a flexible divided ring provided with a series of laterally-projecting pins, of two superposed plates provided with slots which cross each other and engage with the said pins, and means for revolving one of the said plates relative to the other to adjust the said ring, substantially as set forth.

2. In an expansible wheel, the combination, with a flexible divided ring provided with a series of laterally-projecting pins, of two superposed plates provided with slots which cross each other and engage with the said pins, a retractible locking device normally connecting the said plates, and means for revolving one of the said plates relative to the other when the said locking device is retracted, substantially as set forth.

3. In an expansible wheel, the combination, with a flexible divided ring provided with a series of laterally-projecting pins, of two superposed plates provided with slots which cross each other and engage with the said pins, one of the said plates being provided with a toothed segment, a toothed pinion and a star-wheel secured together and journaled in the other said plate, said pinion engaging with the said segment, and a tappet for the said star-wheel to engage with as the said plates are revolved, whereby one plate is re-

volvcd relative to the other, substantially as set forth.

4. In an expansible wheel, the combination, with a flexible divided ring provided with a series of laterally-projecting pins, of two superposed plates provided with slots which cross each other and engage with the said pins, tappet mechanism operating to revolve one of the said plates relative to the other step by step at each revolution of the said plates, and means for throwing the said tappet mechanism out of action automatically at prearranged points, substantially as set forth.

5. In an expansible wheel, the combination, with a flexible divided ring provided with a series of laterally-projecting pins, of two superposed plates provided with slots which cross each other and engage with the said pins, one of the said plates being provided with a toothed segment, a toothed pinion and a star-wheel secured together and journaled in the other said plate, said pinion engaging with the said segment, a retractible locking device carried by the last-said plate and normally engaging with the said toothed segment, and tappet mechanism operating to retract the said locking device and partially revolve the said star-wheel at each revolution of the said plates, substantially as set forth.

6. In an expansible wheel, the combination, with a flexible divided ring, and mechanism for expanding or contracting the said ring step by step as it revolves; of plates provided with tappets which operate the said mechanism in either direction according to the positions of the said tappets, said plates being also provided with slots arranged at an angle to each other, and an actuating-rod which is operatively connected with the said slots so that the said plates are moved laterally of the said divided ring in opposite directions so as to place one or the other in action, substantially as set forth.

In testimony whereof I affix my signature in the presence of two witnesses.

WILLIAM DYSON WANSBROUGH.

Witnesses:

JAMES ODAM,
C. W. PAULGER.