



(43) International Publication Date
26 September 2013 (26.09.2013)

(51) International Patent Classification:

B65G 59/06 (2006.01) G01M 1/32 (2006.01)
F16F 15/32 (2006.01)

(21) International Application Number:

PCT/EP2013/054740

(22) International Filing Date:

8 March 2013 (08.03.2013)

(25) Filing Language:

English

(26) Publication Language:

English

(30) Priority Data:

12160441.7 20 March 2012 (20.03.2012) EP

(71) Applicant: WEGMANN AUTOMOTIVE GMBH & CO. KG [DE/DE]; Rudolf-Diesel-Straße 6, 97209 Veitshöchheim (DE).

(72) Inventor: BÜRGELE, Hans Ulrich; Schützenstraße 17, 97849 Roden (DE).

(74) Agent: LOHR, Georg; Junkersstraße 3, 82178 Puchheim (DE).

(81) Designated States (unless otherwise indicated, for every kind of national protection available): AE, AG, AL, AM,

AO, AT, AU, AZ, BA, BB, BG, BH, BN, BR, BW, BY, BZ, CA, CH, CL, CN, CO, CR, CU, CZ, DE, DK, DM, DO, DZ, EC, EE, EG, ES, FI, GB, GD, GE, GH, GM, GT, HN, HR, HU, ID, IL, IN, IS, JP, KE, KG, KM, KN, KP, KR, KZ, LA, LC, LK, LR, LS, LT, LU, LY, MA, MD, ME, MG, MK, MN, MW, MX, MY, MZ, NA, NG, NI, NO, NZ, OM, PA, PE, PG, PH, PL, PT, QA, RO, RS, RU, RW, SC, SD, SE, SG, SK, SL, SM, ST, SV, SY, TH, TJ, TM, TN, TR, TT, TZ, UA, UG, US, UZ, VC, VN, ZA, ZM, ZW.

(84) Designated States (unless otherwise indicated, for every kind of regional protection available): ARIPO (BW, GH, GM, KE, LR, LS, MW, MZ, NA, RW, SD, SL, SZ, TZ, UG, ZM, ZW), Eurasian (AM, AZ, BY, KG, KZ, RU, TJ, TM), European (AL, AT, BE, BG, CH, CY, CZ, DE, DK, EE, ES, FI, FR, GB, GR, HR, HU, IE, IS, IT, LT, LU, LV, MC, MK, MT, NL, NO, PL, PT, RO, RS, SE, SI, SK, SM, TR), OAPI (BF, BJ, CF, CG, CI, CM, GA, GN, GQ, GW, ML, MR, NE, SN, TD, TG).

Published:

— with international search report (Art. 21(3))

(54) Title: APPARATUS AND METHOD FOR DISPENSING VEHICLE BALANCING WEIGHTS

Fig. 1

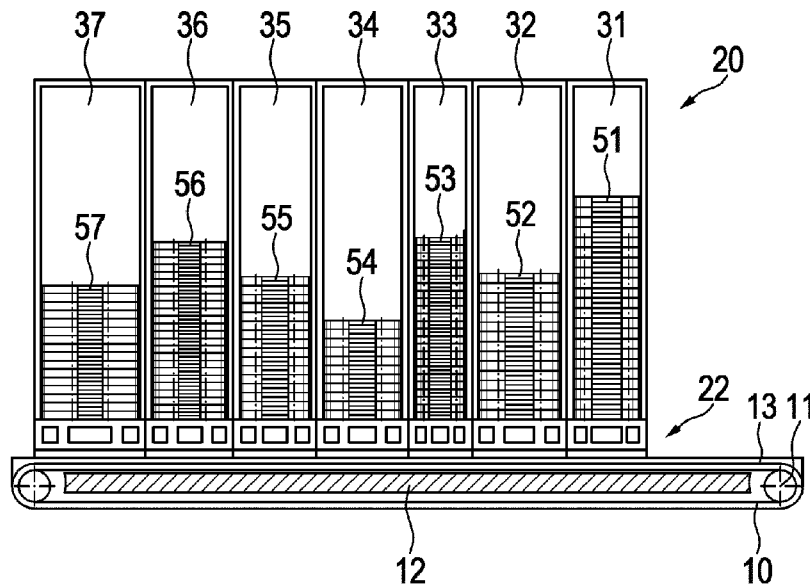

(57) Abstract: An apparatus and a method for dispensing vehicle balancing weights (51-57) are disclosed. The dispenser comprises of a transport unit (22) arranged below a cartridge (20) for storing balancing weights (51-57). The transport unit (22) moves a balancing weight (51-57) from a selected section (31-37) of the cartridge (20) on a belt (10) conveyor for further transporting the balancing weight (51-57) to a handling device. The transport unit comprises a feeder, and a plurality of stack lifters for lifting a stack of balancing weights (51-57) and allowing the feeder to push a selected balancing weight under the stack of other balancing weights (51-57) towards the belt conveyor (10).

WO 2013/139626 A1

Apparatus and Method for Dispensing Vehicle Balancing Weights

Field of the invention

The invention relates to methods and devices for dispensing weights used in vehicle ballasting applications, in particular for dispensing weights used in balancing automobile or other vehicle wheels.

Description of the related art

In automotive wheel balancing, individual wheel balancing weights are applied to specific positions of a rim. Basically, two types of balancing weight are used. The first kind is a balancing weight which is attached by a clamp, as disclosed in the European patent EP 1 613 876 B1, while the second kind is fixed by means of a self-adhesive tape, as disclosed in US patent 6,364,421 B1.

Both kinds of balancing weights are available in a plurality of sizes, resulting in different weights. When balancing a vehicle wheel, the correct size of balancing weight is selected and attached to the rim. Most balancing weights are supplied as bulk material in boxes, from which the required number of weights is manually taken.

This allows for a simple, comparatively cheap supply of balancing weights. The drawback is that the person who is taking the weights from the box may take a wrong weight, and therefore a further step of balancing is required. Furthermore, the process of taking the weights can hardly be automated. Therefore, other solutions as disclosed in WO 2008/103651 A1, using a continuous polymer tape, have been developed. This has the drawback that a solid balancing weight is significantly more robust and reliable than these continuous tapes.

DE 27 45 858 A1 discloses an apparatus for dispensing of components from a cartridge by means of a transport unit and a belt conveyor.

Summary of the invention

- 5 The problem to be solved by the invention is to provide an apparatus and a method for automatic dispensing vehicle balancing weights, dispensing one or a plurality of weights adapted for a required balancing task. The weights should be dispensed in such a way that they can be handled by an automatic handling system for applying the weights to a rim.
- 10 At least one cartridge is attached to at least one transport unit for selecting individual weights from the cartridge and moving the selected weights to a belt conveyor in front of the drive unit. The at least one cartridge comprises a plurality of trays, wherein each tray can hold vehicle balancing weights. The trays may be designed to hold a plurality of different balancing weights. They furthermore
- 15 may be adapted to specific sizes of balancing weights. The trays may have a visible and/or computer readable encoding of at least one of tray size, tray capacity, balancing weight size, quantity of balancing weights in the tray. This may be done by a printed code like a number, a bar code or an electronic code like a transponder or a memory chip which may be contacted by a microcontroller.
- 20 Such an encoding may also be applied to the at least one cartridge. Furthermore, it is preferred, if each tray comprises at least one section, preferably at least two sections or a plurality of sections which may be suited for accommodating different balancing weights. Each section may contain a single stack or a plurality of stacks of balancing weights. Preferably there are successive stacks or section.
- 25 The transport unit has at least one feeder for moving a selected balancing weight from a specific section of one of the trays to the belt conveyor. The feeder pref-

erably performs a linear movement and preferably is driven by a linear drive. Furthermore, at least one stack lifter is provided for lifting a stack of balancing weights within a section of the trays. Preferably there is one stack lifter provided for each section. There may be no stack lifter at the sections being most distant

5 from the belt conveyor for each feeder. These stack lifters are interacting with the feeder. The feeder is moving one selected balancing weight to the belt conveyor which is lying on a transport surface from a tray section. The balancing weights of the other sections which are not selected either are lifted by stack lifters above the feeder or are sliding on the feeder's surface and remain within

10 their sections, so that they cannot be transported to the belt conveyor. The feeder may be operated in two different modes, which may be combined. In a first mode, the balancing weights are accessed sequential. Here, the feeder is pulled back from the belt conveyor with its end to a position behind the first section closest to the belt conveyor, but before the second section. When the feeder has reached this position, the whole stack of balancing weights in the first section

15 falls down so that the balancing weight at the bottom lies on a transport surface. Now, the feeder may be pushed forward, pushing the bottom balancing weight towards the belt conveyor, until the balancing weight falls on the belt conveyor. Then, the cycle is repeated again. If one section is empty, the procedure is repeated with the next section until all sections are empty. In a different

20 embodiment of the feeder, the feeder may have an opening suited for accommodating one balancing weight. In this embodiment, the feeder is also pulled back from the belt conveyor until the balancing weight at the bottom of the first section closest to the belt conveyor can fall into this opening. Then, the direction

25 of the feeder is reverted towards the belt conveyor and the balancing weight is transported to the belt conveyor. After all balancing weights of the first section have been transported to the belt conveyor, the feeder moves until it reaches the next section containing balancing weights, which may be the second section, and repeats the same procedure as before. In this way, one section after the

other may be emptied. This mode of operation even works without stack lifters. Therefore, according to a simplified embodiment, only a feeder is provided for transporting the balancing weights from the at least one cartridge to the belt conveyor. In this case, the balancing weights are sliding on the surface of the feeder. Therefore, it is further preferred, if the feeder has a surface with a low friction coefficient, which preferably may be achieved by some low friction coating like PTFE.

In a second operating mode, the balancing weights are retrieved from any selected section. This may be useful to select different types of balancing weights like different colors. There is at least one stack lifter which is interacting with the feeder. Preferably, the stack lifters lift up all stacks in sections which are not the selected one. If, for example, the second section is selected, it is preferred, if the stack lifters lift the stack of balancing weights in the first, third, and all consecutive sections up, so that the feeder can be moved without transporting and preferably without touching any one of the balancing weights of these sections. Only the stack lifter of the selected second section remains inactive, therefore allowing the balancing weights of the second stack to fall down to the transport surface after the feeder has been pulled back sufficiently. If the feeder is pushed forward towards the belt conveyor with the selected balancing weight, it has to pass other not selected sections, like the first section in this example. Before passing such sections, the stack lifter must lift the stack in such sections. In an alternative embodiment, the stack may be lifted all the time. In this in the above example, preferably, the stack lifter of the first section has to lift the stack as soon as the selected balancing weight moves below the first stack and therefore can bear the load of the stack of balancing weights. By using this mode, any kind of balancing weights may be transported. It is not necessary to have shapes of balancing weights which allow sliding of stacked balancing weights against each other, as the balancing weights are held and guided by the stack lifter, the feeder and the latch.

In a further embodiment, an additional latch is provided which prevents the balancing weights falling down after a stack lifter has been retracted. The latch may be closed locking a stack in its position, until this stack is selected again.

As disclosed, any section of a tray may be selected for delivering a balancing weight to the belt conveyor. In a first embodiment, all sections of a tray may
5 contain the same size of balancing weights, although it is also possible to use different sizes of balancing weights within different sections of the same tray. Furthermore, it may be possible to use different sections with different colors and/or design of balancing weights, preferably of the same size.

10 In a further preferred embodiment, there is at least one conveyor sidewall at at least one side of the belt conveyor, preventing balancing weights on the belt conveyor to leave the belt conveyor. Furthermore, the sidewalls may be designed to align the balancing weights transported on the belt conveyor. The conveyor sidewalls may further be dynamically adjustable by a drive to bring the
15 transported balancing weight into a specific position at the belt conveyor.

In a further embodiment, at least one sensor is provided for detecting, whether at least one balancing weight is available in a section of the cartridge. This allows for control of selection of individual weights.

By using the apparatus disclosed herein, balancing weights may be selected and
20 delivered with a comparatively high speed. Furthermore, by using multiple cartridges and/or trays in parallel, containing the same type of balancing weight, the speed of deliverance, which may be limited by mass inertia, specifically of the stacks of balancing weights, may be increased. When a section of the cartridge has become empty, it may be continuously refilled during operation without af-
25 fecting operation. In an alternative embodiment, individual sections, trays, or cartridges may be replaced by refilled sections trays or cartridges. In a further embodiment, at least two sections, trays, or cartridges may be used in parallel to

the same belt conveyor, while one is in operation, and the other is being replaced or being refilled.

A further embodiment of the invention relates to a method for dispensing vehicle balancing weights. The method comprises at least the steps of providing balancing weights within a cartridge, preferably comprising at least one tray and
5 further comprising at least one section containing at least one balancing weight. The further steps comprise of selecting at least one section and transporting by a transport unit the bottommost balancing weight of the section to a belt conveyor. A further step comprises transporting the selected balancing weight by the
10 belt conveyor to at least one chute or tray. In a further optional step, a selected tray of a plurality of trays may be moved into a position relative to the belt conveyor. In a next step the balancing weight transported on the belt conveyor is transported into the tray.

In a further embodiment of the invention, there may be at least one tray at the
15 end of the belt conveyor. The at least one tray may be fed by a chute; it may be part of a chute or may contain a chute. In a preferred embodiment, a plurality of trays which is moveable against the belt conveyor is arranged at the end of the belt conveyor, allowing to select at least one of the trays, where an individual balancing weight is delivered. This allows for commissioning of a plurality of bal-
20 ancing weights which are required for a balancing task.

In a further embodiment, the cartridge, the trays, or sections thereof are removable or exchangeable.

Preferably, a belt conveyor is used to transfer at least one balancing weight from the transport unit to a handling device. This may be any automated system like
25 an industrial robot. In specific cases, the balancing weights may also be manually handled. There may be any intermediate device like a chute or trays.

In a further embodiment, a controller is provided for controlling the transport unit. The controller may receive as an input signal a parameter describing which type of balancing weight is desired or describing a specific section and/or tray and/or cartridge from which a balancing weight is desired. It may further supply
5 a time at which the balancing weight should be delivered. The controller is then controlling the transport unit and preferably the belt conveyor in such a way, that the selected balancing weight is received at the end of the belt conveyor at the optionally specified time. Most preferably, the controller controls the feeder drives and the stack lift actuators, and the drives of the latches, as well as any
10 further actuators. Furthermore, it evaluates signals from sensors, like the sensors for checking the availability of balancing weights in individual sections. It may furthermore evaluate signals from any further sensors. In addition, it may control the speed of the belt conveyor, and/or the position of trays.

15 It is obvious that the embodiments disclosed herein are applicable to a broad variety of balancing weights like balancing weights which may be held by a clamp or self-adhesive balancing weights.

Description of Drawings

20 In the following the invention will be described by way of example, without limitation of the general inventive concept, on examples of embodiment with reference to the drawings.

Figure 1 shows an apparatus for dispensing vehicle balancing weights.

25 Figure 2 shows the apparatus in a top view.

Figure 3 shows a cross-section of the apparatus.

Figure 4 shows a front view of the transport unit.

Figure 5 shows a top view of the feeder.

Figure 6 shows a different feeder.

5 Figure 7 shows the belt conveyor with a tube.

Figure 8 shows the belt conveyor with trays.

Figure 9 shows a second belt conveyor.

In Figure 1, a preferred embodiment according to the invention is shown. A belt
10 conveyor 10 is provided for moving balancing weights from a cartridge 20 to a
chute or at least one tray or any other device for further processing the balanc-
ing weights which may be attached to any one side of the belt conveyor. The belt
conveyor 10 may have a conveyor pulley 11, and it further may have a belt sup-
port 12, which may increase stability on large lengths of the belt. Below the car-
15 tridge 20, there is at least one transport unit 22 for transporting balancing
weights from the cartridge to the belt conveyor. The cartridge 20 may comprise
of at least one tray 31 to 37. These trays may be filled with balancing weights 51
to 57. In the individual trays, there may be different numbers, different sizes,
different types, different colors, and different designs of balancing weights.

20 In Figure 2, a top view of the dispensing apparatus is shown. Here, a first car-
tridge 20 is shown on one side of the belt conveyor, and a second cartridge 21 at
the other side. The belt conveyor 10 has conveyor sidewalls 13 and 14, prevent-
ing balancing weights from falling off the belt conveyor. The cartridges have indi-
vidual trays 31 to 37 which are further subdivided into sections 41 to 44. Each

tray may have an individual number of sections, although it is preferred to have the same number of sections. The cartridges may have a different number of trays and sections as shown herein. Furthermore there may be only one of the cartridges at one side of the belt conveyor. Alternatively there may be a higher
5 number of cartridges.

In Figure 3, an embodiment is shown in a cross-section in detail. In the center, belt conveyor 10 is shown with conveyor sidewalls 13 and 14. At both sides of the conveyor sidewalls, transport units 22 and 23 are shown. On top of the transport units are cartridges 20, 21, showing sections 41 to 44 and containing
10 balancing weights 51. The main part of the transport unit are the feeders 60, 65, which can be moved into directions 62, 67 by means of feeder drives 61, 66. Furthermore, a plurality of stack lifters 81 to 84 associated with transport unit 22, and stack lifters 85 to 88 associated with transport unit 23 are provided. These stack lifters may lift the stacks of balancing weights within the sections which are
15 not selected. The stack lifters are operated by stack lift actuators 71 to 78, which may for example be solenoids, electromagnetic, hydraulic or pneumatic drives.

In Figures 4a, 4b and 4c, details of the operation of the stack lifter and the feeders in the transport unit are shown. Figure 4a shows the starting position, where stack lifters 81 are in an idle position. Balancing weights 51, 52, and 53 are supported on a transport surface 80. The latches 90 are also in an idle position. Figure
20 4b shows the next step of operation, when the stack lifters 81 are moved upwards, thereby lifting the stack of balancing weights one position up. Accordingly, now an open space of the height of at least one balancing weight is below the previously bottommost balancing weight 51. In this Figure, balancing weight
25 58 belonging to a section behind the section shown can be seen. In an exemplary embodiment, this balancing weight is of a smaller size and therefore shorter than the balancing weights 51, 52, 53 in the front section. The next step of operation is shown in Figure 4c. Here, stack lifters 81 are again brought into their idle posi-

tion. To prevent the stack of balancing weights 51, 52, 53 from falling back to the transport surface 80, latches 91 are brought into operation position, where guides 91 interact with the bottommost balancing weight 51, thus keeping the whole stack in a lifted position and allowing balancing weight 58 to be moved
5 along transport surface 80 by a feeder 60, 65 (not shown herein).

Further details of the operation of the feeder are shown in Figure 5. It shows a top view, in which the individual stack lifters 81, 82, 83, belonging to different sections 41, 42, 43 are shown. They may lift individual balancing weights 51 as previously explained. Preferably, the feeder 60 is fork-shaped to allow move-
10 ment even when the stack lifters 81, 82, 83 are in their operating position. Generally the number of stack lifters within a section may vary. Dependent of the type of balancing weight, there may be one stack lifter or even three or more stack lifters, which are operated synchronously.

A further embodiment with an alternative feeder 60 is shown in Figure 6. Herein,
15 the feeder has a cut-out section 68 for holding balancing weight 51. This allows for more precise transport and positioning of balancing weight 51.

In Figure 7, a side view of the belt conveyor is shown. The belt conveyor may have a belt support 12 and a conveyor pulley 11 at its end. Furthermore, a chute 100 may be provided for transporting the balancing weight from the conveyor
20 pulley.

In Figure 8, a top view of a belt conveyor 10 is shown. Preferably, there are at least one or two sidewalls 13, 14, which preferably may be adjusted in a distance for aligning balancing weights 51 during transport by the belt conveyor. At the end of the belt conveyor, there may further be provided at least one, preferably
25 a plurality of trays 101, 102, which may be moved into the direction 103 for selecting an individual tray into which the balancing weight is transported.

In Figure 9 a second belt conveyor is shown. It comprises a second belt 120, second conveyor pulleys 121, 122 and a support 123. This belt conveyor may be controlled independent of the first belt conveyor. Therefore it may be used as a platform for a handling device like an industrial robot to pick up a balancing weight. Here the second belt conveyor brings the balancing weight into the correct position for picking up, which may be dependent on weight size and type. At the same time the first belt conveyor may be running and transporting the next balancing weight. Of course the first belt conveyor may also be used to deliver a balancing weight to a position from which it can be picked up. By using two conveyors, transport over a longer distance between the cartridges, which also takes time can be separated from picking up and results in a significant increase of delivering speed and throughput.

List of reference numerals

| | | |
|----|-----------|--------------------------------|
| | 10 | belt conveyor |
| | 11 | conveyor pulley |
| 5 | 12 | belt support |
| | 13, 14 | conveyor sidewalls |
| | 20, 21 | cartridge |
| | 22, 23 | transport unit |
| | 31 – 37 | trays |
| 10 | 41 – 44 | sections |
| | 51 – 57 | balancing weights |
| | 60, 65 | feeder |
| | 61, 66 | feeder drive |
| | 62, 67 | feeder movement direction |
| 15 | 68 | cut-out section |
| | 71 – 78 | stack lifter actuators |
| | 80 | transport surface |
| | 81 – 88 | stack lifters |
| | 90 | latch |
| 20 | 91 | guide |
| | 100 | chute, tray |
| | 101, 102 | trays |
| | 103 | direction of movement of trays |
| | 111 – 118 | sensors |
| 25 | 120 | second belt |
| | 121, 122 | second conveyor pulleys |
| | 123 | support |

Claims

1. Apparatus for dispensing vehicle balancing weights comprising
 - at least one cartridge (20, 21) adapted to store at least one balancing weight (51 to 57), the cartridge further comprising at least two sections (41 to 45);
 - a belt conveyor for transporting at least one balancing weight to a handling device;
 - at least one transport unit (22, 23), located below the at least one cartridge, for transporting a balancing weight from a selected section to the belt conveyor (10),
the at least one transport unit comprises a feeder for moving the balancing weight from the selected section and pushing it on the belt conveyor,
the feeder performs a linear movement into a direction to the belt conveyor,
- characterized in that
- at least one stack lifter (81 to 88) is provided for lifting a stack of balancing weights in sections between the selected section and the belt conveyor to allow the feeder to shift the balancing weight towards the belt conveyor under the lifted stack of balancing weights.
2. Apparatus according to any one of the previous claims,
characterized in that
the at least one feeder (60, 65) is fork-shaped and has cut-outs for the stack lifters 81 to 88.

3. Apparatus according to any one of the previous claims,
characterized in that
the at least one feeder (60, 65) has a cut-out section for accommodating at
least one balancing weight.

- 5 4. Apparatus according to any one of the previous claims,
characterized in that
at least one sidewall (13, 14) is provided at the sides of the belt conveyor
(10).

- 10 5. Apparatus according to any one of the previous claims,
characterized in that
at least one cartridge (20, 21) and at least one transport unit (22, 23) is
provided to each of the both sides of the belt conveyor.

- 15 6. Apparatus according to claims 4 or 5,
characterized in that
at least one of the conveyor sidewalls (13, 14) is adjustable for aligning at
least one balancing weight being transported by the belt conveyor.

7. Apparatus according to any one of the previous claims,
characterized in that
a chute is provided at at least one end of the belt conveyor.

- 20 8. Apparatus according to any one of the previous claims,
characterized in that
at least one tray (101, 102) is provided at one end of the belt conveyor.

9. Apparatus according to claim 8,
characterized in that
the at least one tray (101, 102) is moveable, so that any selected tray may
be loaded by the belt conveyor.
- 5 10. Method for dispensing vehicle balancing weights, comprising the steps of
- providing a cartridge (20, 21) which contains at least one balancing
weight (51 to 57);
 - selecting a section of the cartridge from which a balancing weight
should be taken;
- 10
- lifting the stack of balancing weights in sections between the se-
lected section and the belt conveyor;
 - pushing the bottommost balancing weight of the selected section
under the sections with previously lifted balancing weights onto the
belt conveyor.
- 15 11. Method according to claim 10, further comprising the step of transporting
a balancing weight by the belt conveyor to a handling device.

Fig. 1

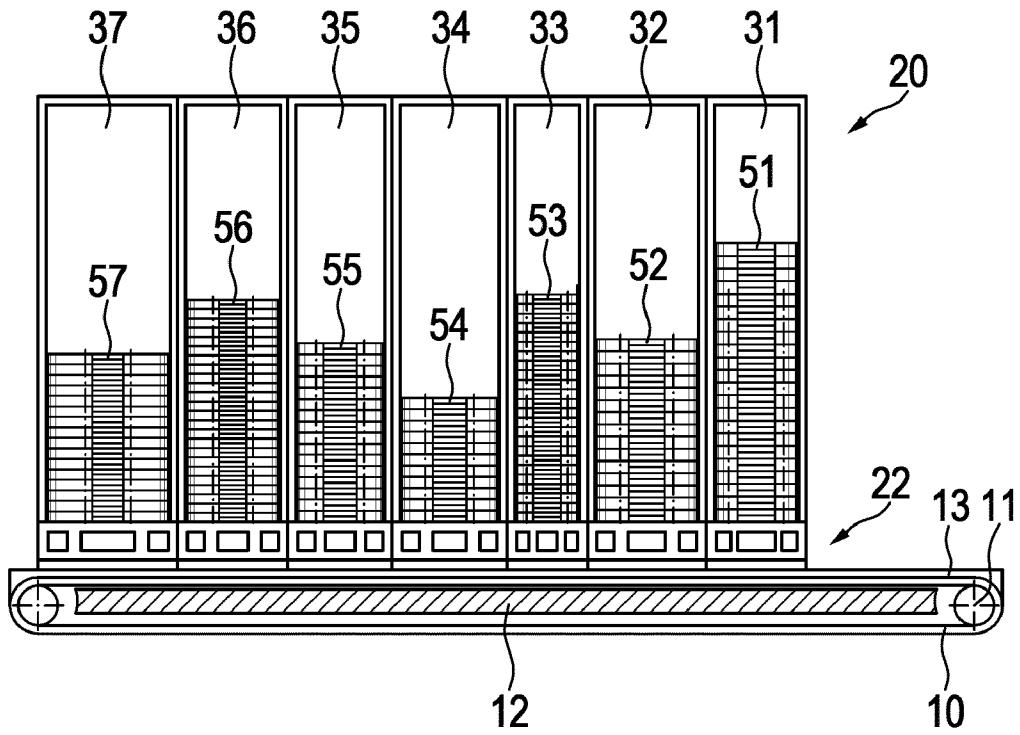

Fig. 2

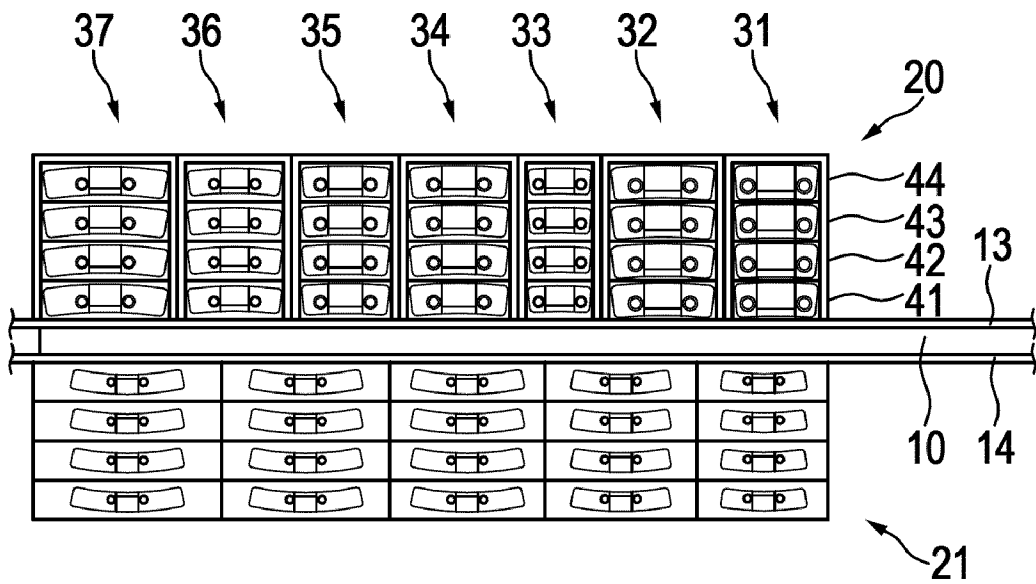

Fig. 3

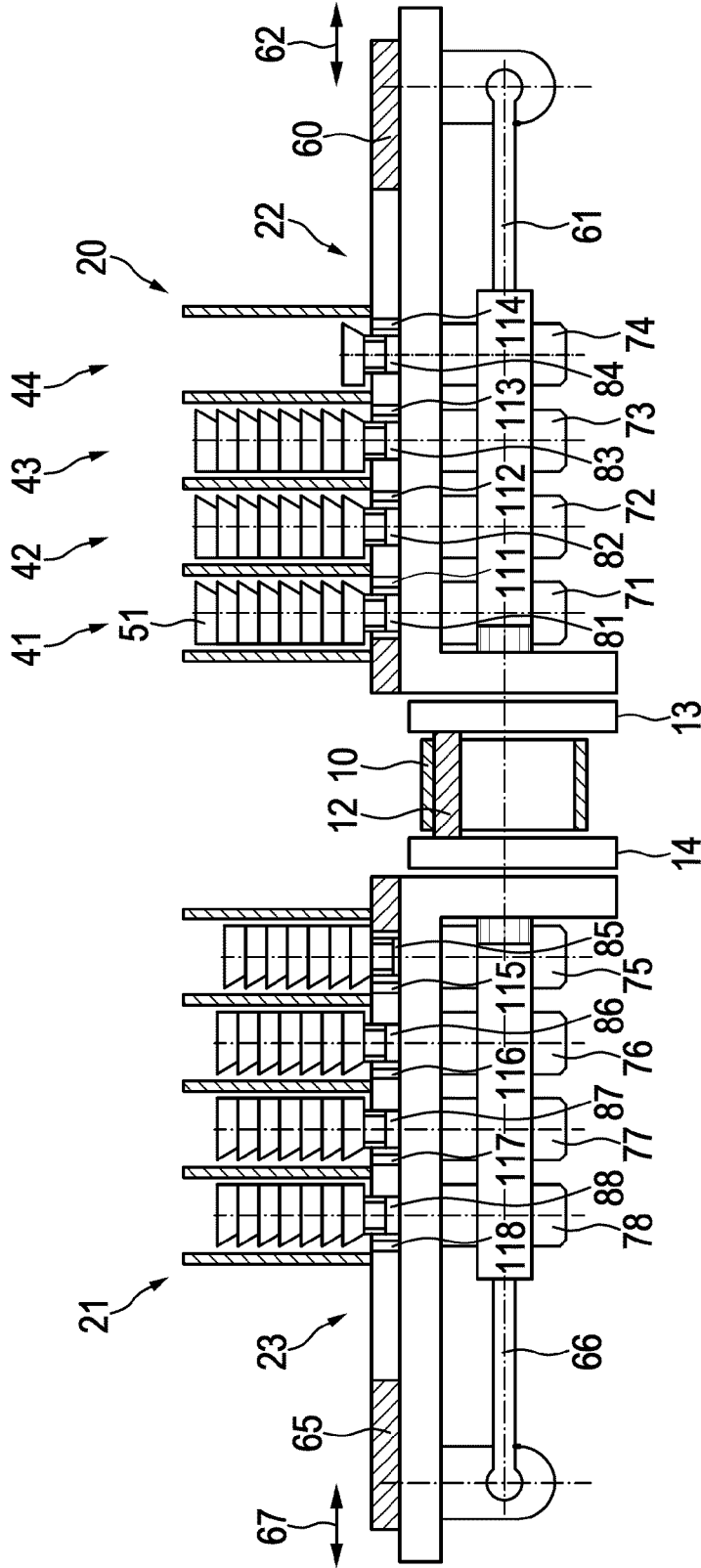

Fig. 4a

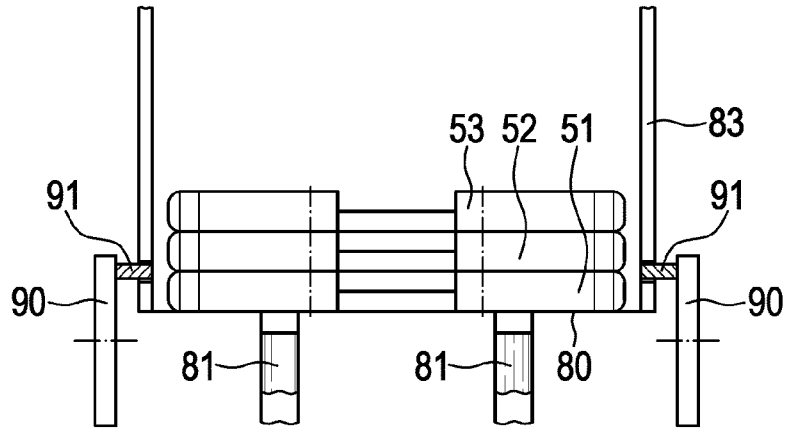

Fig. 4b

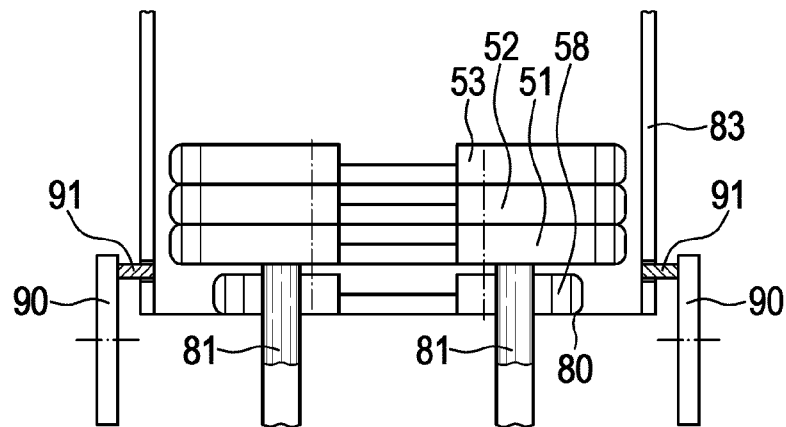

Fig. 4c

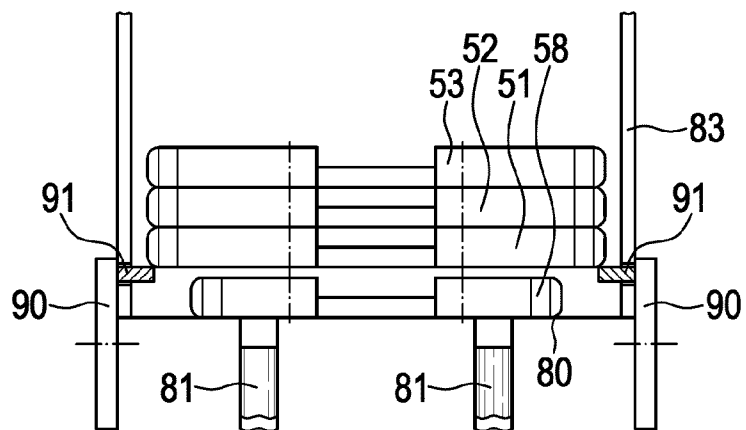

Fig. 5

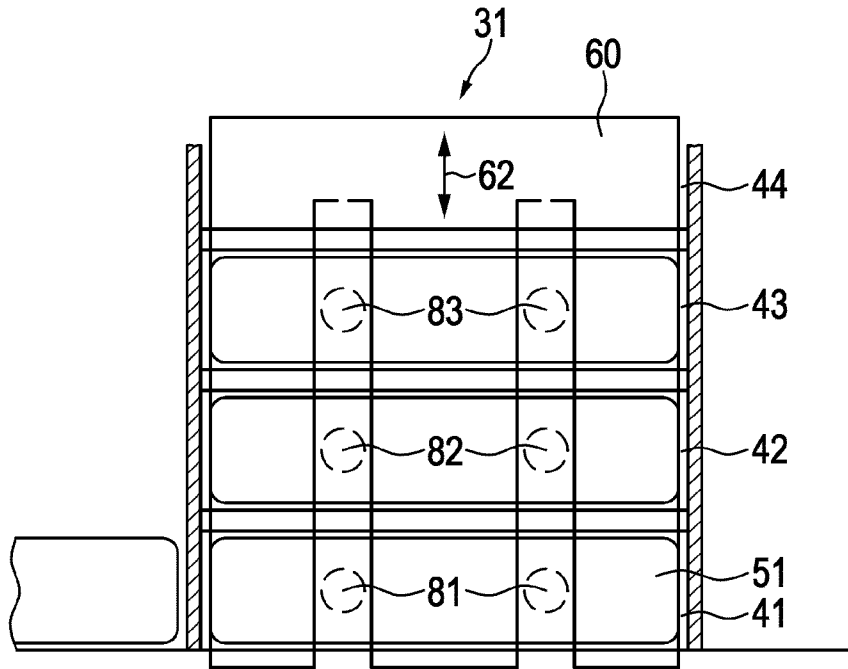

Fig. 6

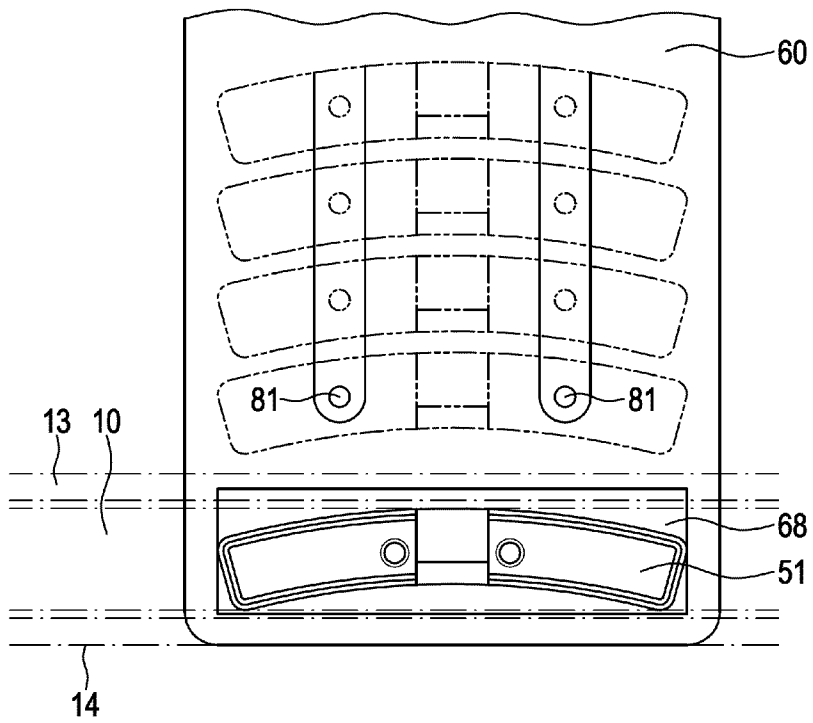

Fig. 7

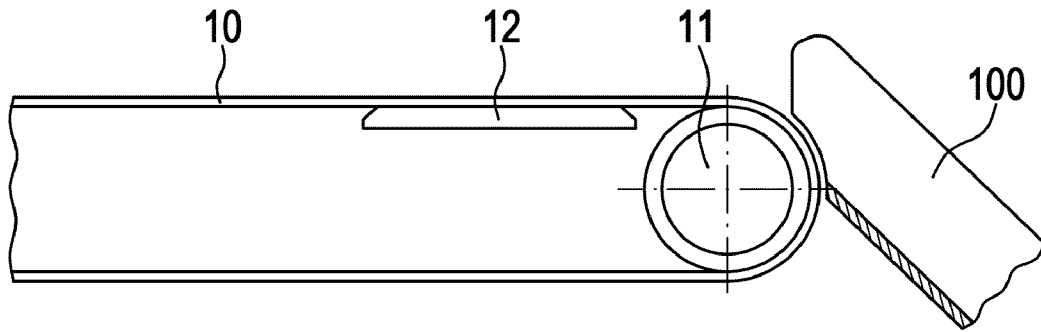

Fig. 8

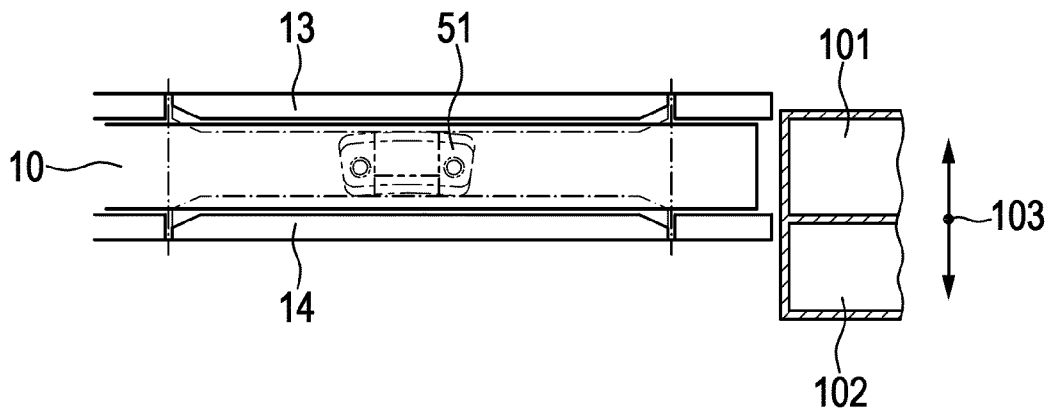
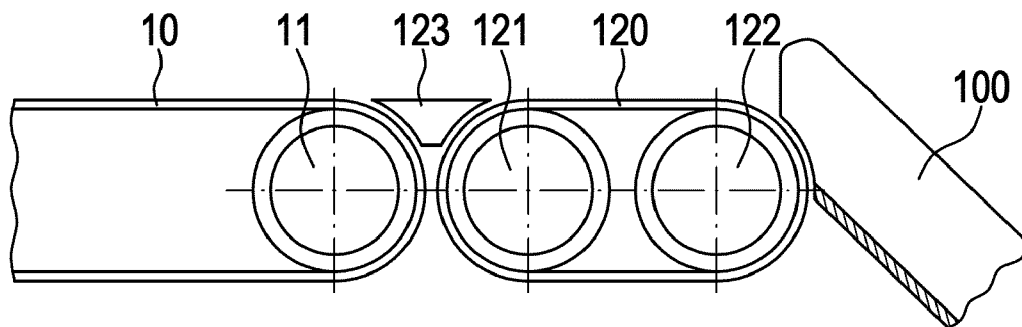

Fig. 9



INTERNATIONAL SEARCH REPORT

International application No
PCT/EP2013/054740

A. CLASSIFICATION OF SUBJECT MATTER
INV. B65G59/06 F16F15/32 G01M1/32
ADD.
According to International Patent Classification (IPC) or to both national classification and IPC

B. FIELDS SEARCHED
Minimum documentation searched (classification system followed by classification symbols)
B65G F16F G01M G07F

Documentation searched other than minimum documentation to the extent that such documents are included in the fields searched

Electronic data base consulted during the international search (name of data base and, where practicable, search terms used)
EPO-Internal, WPI Data

C. DOCUMENTS CONSIDERED TO BE RELEVANT

| Category* | Citation of document, with indication, where appropriate, of the relevant passages | Relevant to claim No. |
|-----------|--|-----------------------|
| X | DE 27 45 858 A1 (HETHEY ARTUR) 19 April 1979 (1979-04-19) figures 1-4 claim 5 page 4, lines 6-20 | 1,3-9 |
| A | FR 2 838 114 A1 (GOUY JEAN CLAUDE [FR]; NEYTON JEAN YVES [FR]) 10 October 2003 (2003-10-10) figures 1,2 page 5, line 32 - page 6, line 8 page 8, lines 5-12 | 1,3-8 |
| A | DE 83 13 868 U1 (SIEMENS AG) 4 December 1986 (1986-12-04) figure 1 | 1,3-8 |
| | ----- -/-- | |

Further documents are listed in the continuation of Box C.

See patent family annex.

* Special categories of cited documents :

"A" document defining the general state of the art which is not considered to be of particular relevance

"E" earlier application or patent but published on or after the international filing date

"L" document which may throw doubts on priority claim(s) or which is cited to establish the publication date of another citation or other special reason (as specified)

"O" document referring to an oral disclosure, use, exhibition or other means

"P" document published prior to the international filing date but later than the priority date claimed

"T" later document published after the international filing date or priority date and not in conflict with the application but cited to understand the principle or theory underlying the invention

"X" document of particular relevance; the claimed invention cannot be considered novel or cannot be considered to involve an inventive step when the document is taken alone

"Y" document of particular relevance; the claimed invention cannot be considered to involve an inventive step when the document is combined with one or more other such documents, such combination being obvious to a person skilled in the art

"&" document member of the same patent family

| | |
|--|--|
| Date of the actual completion of the international search 23 April 2013 | Date of mailing of the international search report 03/05/2013 |
|--|--|

| | |
|--|--|
| Name and mailing address of the ISA/ European Patent Office, P.B. 5818 Patentlaan 2 NL - 2280 HV Rijswijk Tel. (+31-70) 340-2040, Fax: (+31-70) 340-3016 | Authorized officer Bizzarri, Didier |
|--|--|

INTERNATIONAL SEARCH REPORT

International application No
PCT/EP2013/054740

| C(Continuation). DOCUMENTS CONSIDERED TO BE RELEVANT | | |
|--|---|-----------------------|
| Category* | Citation of document, with indication, where appropriate, of the relevant passages | Relevant to claim No. |
| A | EP 0 037 989 A1 (GUIGAN JEAN) 21 October 1981 (1981-10-21) figures 2,3,9 abstract ----- | 1-10 |

INTERNATIONAL SEARCH REPORT

Information on patent family members

International application No

PCT/EP2013/054740

| Patent document cited in search report | Publication date | Patent family member(s) | Publication date |
|--|------------------|-------------------------|-------------------------|
| DE 2745858 | A1 | 19-04-1979 | NONE |
| ----- | | | |
| FR 2838114 | A1 | 10-10-2003 | NONE |
| ----- | | | |
| DE 8313868 | U1 | 04-12-1986 | NONE |
| ----- | | | |
| EP 0037989 | A1 | 21-10-1981 | BR 8102163 A 13-10-1981 |
| | | CA 1164364 A1 | 27-03-1984 |
| | | DE 3161751 D1 | 02-02-1984 |
| | | EP 0037989 A1 | 21-10-1981 |
| | | ES 8203594 A1 | 16-07-1982 |
| | | FR 2480101 A1 | 16-10-1981 |
| | | IE 50940 B1 | 20-08-1986 |
| | | JP S6335523 B2 | 15-07-1988 |
| | | JP S56155124 A | 01-12-1981 |
| | | US 4423827 A | 03-01-1984 |
| ----- | | | |