

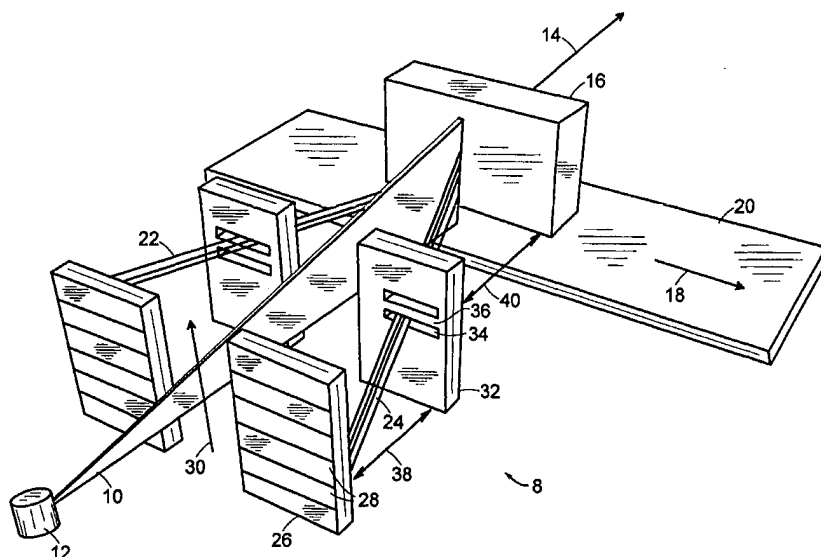

INTERNATIONAL APPLICATION PUBLISHED UNDER THE PATENT COOPERATION TREATY (PCT)

<p>(51) International Patent Classification⁶ : G01T 1/29, G01V 5/00</p>	<p>A1</p>	<p>(11) International Publication Number: WO 98/20366</p> <p>(43) International Publication Date: 14 May 1998 (14.05.98)</p>
<p>(21) International Application Number: PCT/US97/20485</p> <p>(22) International Filing Date: 7 November 1997 (07.11.97)</p> <p>(30) Priority Data: 60/030,714 8 November 1996 (08.11.96) US 60/034,792 19 December 1996 (19.12.96) US</p> <p>(71) Applicant: AMERICAN SCIENCE AND ENGINEERING, INC. [US/US]; 829 Middlesex Turnpike, Billerica, MA 01821 (US).</p> <p>(72) Inventors: HUANG, Suzhou; 101 Western Avenue #66, Cambridge, MA 02139 (US). HYNES, Michael, V.; 11 Stonehedge Road, Lincoln, MA 01773 (US).</p> <p>(74) Agents: SUNSTEIN, Bruce, D. et al.; Bromberg & Sunstein LLP, 125 Summer Street, Boston, MA 02110-1618 (US).</p>		<p>(81) Designated States: JP, European patent (AT, BE, CH, DE, DK, ES, FI, FR, GB, GR, IE, IT, LU, MC, NL, PT, SE).</p> <p>Published <i>With international search report.</i></p>

(54) Title: CODED APERTURE X-RAY IMAGING SYSTEM



(57) Abstract

An X-ray imaging system which measures X-rays scattered by material concealed within an enveloping surface (16). A beam of X-ray radiation (10) is incident on the enveloping surface and scattered onto one or more arrays of detectors (28). One or more masks (32) of material opaque to X-ray transmission but for a series of apertures is interposed between the object and the detectors so as to cast shadows on different parts of the detector array. The image of the scattering material, as detected at the detector array, is modulated by the pattern of mask apertures. A controller reconstructs the image of the illuminated line. By scanning the illumination with respect to the object, an image of the entire object in scattered radiation is obtained, while use of multiple arrays or variation of geometrical settings allows reconstruction of the source of scattering in three dimensions.

FOR THE PURPOSES OF INFORMATION ONLY

Codes used to identify States party to the PCT on the front pages of pamphlets publishing international applications under the PCT.

AL	Albania	ES	Spain	LS	Lesotho	SI	Slovenia
AM	Armenia	FI	Finland	LT	Lithuania	SK	Slovakia
AT	Austria	FR	France	LU	Luxembourg	SN	Senegal
AU	Australia	GA	Gabon	LV	Latvia	SZ	Swaziland
AZ	Azerbaijan	GB	United Kingdom	MC	Monaco	TD	Chad
BA	Bosnia and Herzegovina	GE	Georgia	MD	Republic of Moldova	TG	Togo
BB	Barbados	GH	Ghana	MG	Madagascar	TJ	Tajikistan
BE	Belgium	GN	Guinea	MK	The former Yugoslav Republic of Macedonia	TM	Turkmenistan
BF	Burkina Faso	GR	Greece			TR	Turkey
BG	Bulgaria	HU	Hungary	ML	Mali	TT	Trinidad and Tobago
BJ	Benin	IE	Ireland	MN	Mongolia	UA	Ukraine
BR	Brazil	IL	Israel	MR	Mauritania	UG	Uganda
BY	Belarus	IS	Iceland	MW	Malawi	US	United States of America
CA	Canada	IT	Italy	MX	Mexico	UZ	Uzbekistan
CF	Central African Republic	JP	Japan	NE	Niger	VN	Viet Nam
CG	Congo	KE	Kenya	NL	Netherlands	YU	Yugoslavia
CH	Switzerland	KG	Kyrgyzstan	NO	Norway	ZW	Zimbabwe
CI	Côte d'Ivoire	KP	Democratic People's Republic of Korea	NZ	New Zealand		
CM	Cameroon			PL	Poland		
CN	China	KR	Republic of Korea	PT	Portugal		
CU	Cuba	KZ	Kazakstan	RO	Romania		
CZ	Czech Republic	LC	Saint Lucia	RU	Russian Federation		
DE	Germany	LI	Liechtenstein	SD	Sudan		
DK	Denmark	LK	Sri Lanka	SE	Sweden		
EE	Estonia	LR	Liberia	SG	Singapore		

Coded Aperture X-Ray Imaging System

Technical Field of the Invention

5 The present invention relates to a system and method for reconstructing an image of a concealed object from X-ray radiation scattered by the concealed object. It is suited to detecting contraband, such as explosives, weapons or drugs which are concealed in an enveloping surface such as airline baggage or a shipping container.

Background of the Invention

10 The use of scattered X-ray radiation for detection of concealed objects has been taught in many patents. It is well known that X-ray detectors may be placed at any position with respect to the object under scrutiny in order to capture photons scattered through the Compton process by the medium under scrutiny. The various placements of X-ray detectors around the object correspond to forward scatter, backscatter, and side scatter detectors, as the case may
15 be. Since the number of X-ray photons scattered into a given solid angle is small, it is often desirable to capture scattered photons from a large solid angle in order to increase the sensitivity of the detection process. The use of large-area detectors, however, requires the implementation of stratagems in order to determine the precise origin, within the enveloping
20 surface, of the detected photons, i.e., to spatially resolve the shape of the object under scrutiny even if it cannot be observed directly because it is contained within an enveloping surface.

 One method of achieving spatial resolution has been to illuminate the object under scrutiny with a "pencil beam" or "flying spot" of X-ray radiation that is scanned with respect to the object in some sort of raster pattern. Obviously, motion of the object, as on a conveyor
25 belt in one direction, is equivalent to a corresponding motion of the X-ray beam. Using this stratagem, only a particular position in a plane transverse to the propagation axis of the X-ray radiation is illuminated at a particular moment, so that an image of the entire scanned object can be reconstructed, but only after the scan is complete.

 Using the raster-scanned flying-spot method, each position in the object is only
30 illuminated for a small duration of time, since the entire area of the piece of luggage, for example, must be scanned as the luggage is conveyed on a conveyor belt across the path of the X-ray beam. Under these circumstances, sensitivity may be limited by noise since the system is typically "photon-starved." Spatial resolution is limited to the size of beam, at best,

though actual resolution is typically worse due to the necessity of spatial averaging. It is, thus, desirable to gain a multiplex advantage by simultaneously illuminating a larger fraction of the object than would be illuminated by a beam corresponding roughly to the size of a spatial resolution element. To gain this advantage, it is necessary to implement another stratagem for reconstructing an image of the scattering source.

Additionally, implementation of a pencil beam method may entail the weight and mechanical complexity associated with the use of a chopper wheel for moving a heavy lead aperture in order to shape a high-energy x-ray beam.

Summary of the Invention

In accordance with one aspect of the invention, in one of its embodiments, there is provided an imaging system for analyzing material. The imaging system has a source of penetrating radiation, the source emitting radiation in an illumination direction with respect to the object such as to illuminate a portion or the entirety of the object. Additionally, the imaging system has at least one array of segmented detectors, each array of segmented detectors having a detector axis, where each array of segmented detectors detects radiation scattered by the object and provides signals corresponding to the detected radiation. Finally, the imaging system has a mask with a plurality of apertures interposed between the object and each detector array. The source of penetrating radiation may be an X-ray source, and may be substantially monoenergetic. In alternate embodiments of the invention, the source of penetrating radiation may emit a beam of radiation along a beam opening angle disposed with an orientation with respect to the illuminated object such as to illuminate a line on the object, and the detector axis or axes may have a vector component substantially parallel to the illuminated line. In a further alternative embodiment, the imaging system also has a scanning arrangement for moving the beam relative to the object in a direction having a component transverse to the orientation of the beam opening axis and a controller for reconstructing the image of the scattering object using the signals corresponding to the detected radiation.

In accordance with yet another embodiment of the present invention, the source of penetrating radiation emits pulses having a temporal feature of duration less than the time scale of propagation through the object and may further include an electronic circuit for resolving the distance between the source of scattered emission and the array of segmented

detectors. The arrays of segmented detectors may also be energy-selective.

In accordance with a further aspect of the present invention, there is provided a method for analyzing concealed material within an enveloping surface, which method has the steps of illuminating a line on the enveloping surface with a beam of penetrating radiation having a beam opening axis disposed with an orientation with respect to the object, providing at least one detector array having an aperture mask interposed between the detector array and the enveloping surface such that radiation scattered by the material is incident onto the detector array through the aperture mask, measuring the radiation scattered by the material onto the detector array, reconstructing an image of the material scattering the radiation, and determining physical properties of the concealed material.

Brief Description of the Drawings

FIG. 1 is a diagram of a coded aperture system x-ray imaging system having segmented backscatter detectors according to an embodiment of the invention.

FIG. 2 is a diagram of a coded aperture x-ray imaging system having segmented backscatter, forward-scatter and transmission detectors according an alternate embodiment of the invention.

Detailed Description of Specific Embodiments

Referring to FIGS. 1 and 2, wherein like reference numerals designate identical or corresponding parts, and, more particularly, to FIG. 1, an X-ray imaging system is designated generally by numeral 8. X-ray beam 10 is emitted by an X-ray source 12 such as is known to persons skilled in the art. Beam 10 may also be comprised of other forms of penetrating radiation and may be monoenergetic, multienergetic, or, additionally, may change spectral characteristics in a temporal sequence. The temporal characteristics of X-ray source 12 and the X-ray beam 10 emitted thereby are discussed in further detail below. In a preferred embodiment of the invention, beam 10 is formed, using standard techniques, into a beam which is narrow in one dimension transverse to propagation axis 14 and fanned out in a second transverse dimension along axis 30, referred to as the beam opening axis. A beam shaped in this manner is referred to as a "fan beam." The present invention is advantageously applied in the case in which beam 10 is shaped as a fan beam, but may be applied, within the scope of this invention, to beams of other shapes.

X-ray beam 10 is configured to illuminate a pattern, which, in the case of a fan beam,

is a line, on a side of a container **16**. Container **16** may be any sort of enveloping surface which prevents the nature of its contents from being readily apparent and may include, for example, a suitcase or other sort of cargo, a car, truck, or other vehicle, an article of clothing, or a person or other subject. The orientation of container **16** is varied with respect to beams **10** so that beam **10** is incident upon container **16** at a variety of positions in temporal sequence. In the preferred embodiment, container **16** moves in horizontal direction **18** past beam **10** on a conveyor belt **20**. Thus, in the course of the passage of container **16** past beam **10**, the entirety of container **16** is illuminated by beam **10**. There are alternative embodiments for providing coverage of a region of interest comprising a portion up to the entirety of a container and these include combinations of moving the container or scanning the beam, which, for purposes of this invention, are considered wholly equivalent. In particular, the beam of penetrating radiation may be scanned mechanically or electronically such as by scanning a cathode ray beam of x-ray source **12** with respect to the anode of the source.

Passage of beam **10** through container **16**, or any other material object, gives rise to scattering of a portion of the X-ray energy in the beam incident on the object. Scattered X-ray energy is emitted through the Compton scattering process into all directions. Rays **22** and **24** are shown as examples of directions in which scattered X-ray radiation is re-emitted by the illuminated object.

In accordance with a preferred embodiment of the invention, one or more segmented detector arrays **26** of X-ray detectors **28** is positioned so as to receive X-ray energy scattered from container **16**. It is to be understood that the precise placement of detector arrays **26** is purely a matter of design choice, since, as stated, scattered X-rays are emitted by container **16** in all directions. The X-ray detector segments **28** are arrayed within each detector array **26** in a direction having a vector component parallel to axis **30** of the long dimension of beam **10**. Detector segments **28** may be extended in the direction transverse to axis **30** in order to intercept scattered X-ray energy with greater efficiency. In the direction of axis **30**, however, the width over which detector segments **28** are sensitive is limited by collimators, or otherwise, so as to provide optimal spatial resolution.

Aperture masks **32** are located in the lines-of-sight between each detector array **26** and container **16** such that scattered X-ray radiation along ray **24** may reach detector array **26** only by traversing aperture mask **32**. Aperture mask **32** contains a linear pattern of open segments

or apertures **34** and closed segments **36**. Apertures **34** and closed segments **36** respectively allow, X-ray radiation to pass and block X-ray radiation, respectively. Aperture masks **32** thus cast X-ray shadows, in a determined pattern, on detector arrays **26**. Since the detection pattern is one-dimensional, the pattern of apertures **34** of aperture masks **32** is realized as a pattern of slits. The pattern of apertures may be quasi-random or may be designed to optimize resolution of objects of a desired range of sizes, according to methods known to persons skilled in the art of super-resolved imaging, as is applied, for example, in astrophysical optics. If used, exclusively, with back-scattered radiation, the material out of which aperture masks **32** are constructed may be thin sheets of lead or tungsten, for example, since back-scatter photons are limited, physically, to half the rest-mass of an electron (255 keV), no matter how energetic the incident X-ray beam **10**.

The use of aperture masks to image the contents of container **16** is described as follows. The material within container **16** which is illuminated by fan beam **10** emits scattered radiation which may be characterized as a linear array s . The shape of the object or objects emitting scattered radiation cannot be determined from the scattered radiation alone, since an entire line of container **16** is illuminated, and since every illuminated point scatters X-rays in all directions. However, scattered radiation **24** passes through aperture mask **32**, which casts a different shadow on detector array **26** depending on the position within container **16** from which the scattered emission originates. The linear distribution of X-ray radiation detected by detector array **26** can be represented as a linear array d . The optical effect of passage of radiation through aperture mask **32** can be represented by aperture matrix A which relates s and detected scattered radiation d according to $d=As$. Since scattered radiation d at detector array **26** has passed through aperture mask **32**, it is a matter of algorithmic manipulation to reconstruct an image of container **16** in backscattered X-ray radiation by finding the pseudo-inverse of aperture matrix A and applying it to the detected signal vector d . Decomposition methods for inverting A are known in the art and may be found in mathematics texts such as Golub & Van Loan, *Matrix Computations* (Baltimore: JHU), which is hereby incorporated by reference.

Reconstruction of the image of container **16** in scattered radiation entails a computation of the pseudo-inverse of aperture matrix A which, in turn, embodies information regarding the pattern of apertures **34** and the respective distances **38** and **40** between detector

array **26** and aperture mask **32** and between aperture mask **32** and the source of scattered X-rays within container **16**. The requisite information is derived either calculationally or on the basis of a calibration procedure, as is known to persons skilled in the art. Since the object **16** being imaged in scattered radiation is comparable in size with the backscatter detector **26**,
5 both the scattering source and aperture mask **32** are effectively in the near-field of the detector, contrary to the case, such as where coded apertures are applied in astrophysics, in which the source is effectively at optical infinity and the incident rays of light are effectively parallel. Additionally, the matrix obtained is typically ill-conditioned and not amenable to standard inversion techniques. Consequently, standard reconstruction algorithms cannot be
10 applied. In a preferred embodiment of the invention, singular value decomposition (SVD) of aperture matrix **A** is used, in a manner which can be proven to be optimal in reducing the mean-square deviation given the noise environment of the detection process and the finite duration of time allowed, for example, in baggage handling applications.

In a preferred embodiment of the invention, for imaging objects on the order of 1
15 meter in size, the number N of aperture elements is typically 256 or 512. The use of SVD in image processing, given full illumination of an object, would require immense resources in both CPU and memory. Construction of an image line by line, as described above in reference to fan-beam illumination, has the advantage of significantly reducing the computational demands of the algorithm. In particular, once aperture matrix **A** has been inverted, through
20 use of the SVD algorithm or otherwise, the computation required in order to reconstruct the desired image scales as N^3 in required CPU and N^2 in memory, since the inverted matrix, resident in memory, is to be multiplied by detected signal vector **d**. A comparable algorithm applied to the entire two-dimensional image would scale as N^4 in both CPU and memory. Once the aperture matrix **A** has been inverted for a given aperture mask **36** and relative
25 placement of object **16**, mask **36**, and detector array **26**, the pseudo-inverse matrix may then be stored and used for all subsequent computations, so that only multiplications need be performed in real time.

Image reconstruction from the detected signal vector **d**, using standard techniques, applies in a straightforward manner to radiation backscattered with angular uniformity via the
30 Compton process. Indeed, the Compton scattering cross section is very flat at backward directions, typically within a 30° cone of the illumination axis in the backward direction.

Persons skilled in the art will recognize that the angular distribution of scattering in the forward direction is a function of the energy of the scattered X-rays. Thus, additional steps, as discussed below, are required to deconvolve the scattering profile. Referring now to FIG. 2, the X-ray imaging system, designated generally by numeral **8** is shown, as in FIG. 1, with the addition of ray **50**, shown to represent a typical direction of forward scattering. At side and forward scattering directions, the non-uniform angular distribution of the Compton scattering exhibits an increasing dependence on the energy of the scattered X-ray photon, particularly when the energy of the incoming photon is comparable with or greater than the rest mass of an electron (≥ 500 KeV).

In the forward scattering case depicted with respect to ray **50** in FIG. 2, one or more segmented detector arrays **52** of X-ray detectors **54** is positioned to receive X-ray energy forward scattered from container **16**. The X-ray detector segments **54** are arrayed within each detector array **52** in a direction having a vector component parallel to axis **30** of the long dimension of beam **10**. Aperture masks **56** contain linear patterns of open segments or apertures **58** in the manner of aperture masks **32** described above with reference to back-scatter. Aperture masks **56** thus cast X-ray shadows, in a determined pattern, on detector arrays **52**. Additionally, a segmented X-ray detector array **60** may be positioned in the direct path of X-ray beam **10** to receive the portion of the X-ray illumination following attenuation by objects within the path of the beam through container **16**. Attenuation data may further complement scatter imaging in the detection of threat materials, in manners known to persons skilled in the art.

Due to the aforesaid dependence of the angular distribution of Compton scattering in the forward direction on photon energy, aperture matrix **A** will have an energy dependence. In order to apply the deconvolution process described above to reconstruct an image of container **16** from X-ray energy forward-scattered through aperture masks **56**, the energy dependence of **A** must be removed, either through system design or algorithmically. In a preferred embodiment, object **16** is illuminated with a nearly monoenergetic X-ray beam **10**. In this case, aperture matrix **A** may be corrected by using the known Compton scattering cross section as a function of angle at the given incident energy, the so-called Klein-Nishina relation, known to persons skilled in the art. Alternative decomposition algorithms include, for example, the use of multiple X-ray beam energies in time sequence, including an energy

chirp, or the placement of aperture masks **54** and associated detector arrays **52** at a plurality of distinct azimuthal angles with respect to incident X-ray beam **10**.

In addition to the use of Compton-scattered photons for image reconstruction, X-ray imaging system may be used to image object **16** in X-ray photons at 0.5 MeV created due to the annihilation of slowed positrons. An incident X-ray beam **10** of energy exceeding 1 MeV will create electron-positron pairs giving rise to the resonant signal. A detector array **26** in the backward direction designed, as known to persons skilled in the art, to discriminate against photons at energies substantially different from 0.5 MeV will provide a low-background signal-to-noise advantage. Similarly, detector array **26** may employ energy selectivity to select for fluorescence or other resonant processes. Thus, the presence of particular atoms may be detected on the basis of X-ray spectroscopic signatures.

Once an image of the scattered radiation is available through application of the teachings above, it is then possible, using techniques known to persons skilled in the art of X-ray threat analysis, to combine the scattering image and the results of other measurements to determine not only the shape but also the density and atomic number of the concealed contents of container **16**. For example, irradiation of container **16** with beam **10** permits simultaneous acquisition of an image of X-ray transmission through container **16**, using a linear array of detectors aligned with the fan beam.

An additional application of the present invention is to X-ray tomography. Since aperture matrix **A** is a function of the relative placement of object **16** and detector array **26**, the depth of the scattering source along the propagation direction **14** of the X-ray beam **10** may be solved for as part of the algorithm, thereby deriving a three-dimensional image of the scatterer. Aperture matrix **A** is sharply in focus for only one geometrical configuration of scatterer with respect to aperture mask **32** and detector array **26**. Use of the pseudo-inverse of aperture matrix **A** sharply decodes the signal corresponding to only this particular geometrical configuration and blurs other signals which are out-of-focus. Since the backscatter signal decays quickly with increasing distance, decoding may be performed, for example, using an iterative method. First, the closest layer is reconstructed and removed from the detected signal. Then the second layer is decoded, followed, seriatim, by successive layers.

The limited contrast resolution provided by the foregoing method may be overcome by application of another embodiment of the invention based on the recognition that the

5 detected signal is a sum over signals derived from a continuum of individual layers. In accordance with this embodiment, either multiple scans are made of the same object using a plurality of geometrical settings or else multiple detector arrays are disposed at differing positions with respect to the object, with an aperture mask corresponding to one or more of the detector arrays. Variation of the geometrical setting may be achieved, for example, by moving the relative placement of the coded aperture with respect to the corresponding detector array, or, alternatively, by moving the scanned object with respect to the coded aperture. Additionally, a combination of multiple geometrical settings and multiple coded apertures may be employed. The signals derived from the multiplicity of detector arrays and geometrical settings are assembled to constitute a super aperture matrix. Each diagonal block of the super aperture matrix corresponds to an aperture matrix of a single scan, in the case of multiple geometrical settings, or to one of the detector arrays, in the multiple detector arrangement. The super aperture array formed in the manner described operates directly on the (three-dimensional) space of the pixel areal position and depth within the object. The SVD method is applied to obtain the pseudo-inverse of the super aperture matrix, thereby providing a solution for each layer within the object. Mixing of blurred signals from other layers may be avoided in this manner.

10 In yet a further alternate embodiment, a pulsed X-ray source **12** is employed to provide a pulsed X-ray beam **10** having a pulse duration, or a temporal feature, which is short on the time scale of propagation of the X-ray beam **10** through object **16**. The precise distance traveled by the scattered X-ray photon to detector segment **28** is determined by electronic circuits, including gated amplifiers, known to persons skilled in the art. This provides true tomographic capability to imaging system **8**.

15 It will be recognized by persons skilled in the art of X-ray imaging that the invention described herein permits the more efficient use of X-ray energy than in previous scatter imaging methods, thereby improving photon statistics and increasing signal-to-noise and sensitivity while reducing power consumption requirements. It will also be recognized that the method and apparatus taught in the present application may be used for areal or tomographic imaging of the body or of organs within the body.

20 The described embodiments of the invention are intended to be merely exemplary and numerous variations and modifications will be apparent to those skilled in the art. All such

variations and modifications are intended to be within the scope of the present invention as defined in the appended claims.

WE CLAIM:

1. An imaging system for analyzing material, comprising:
 - a. a source of penetrating radiation emitting radiation in a direction with respect to an object such as to illuminate a portion of the object up to the entirety thereof;
 - b. at least one array of segmented detectors, each array of segmented detectors having a detector axis, for detecting radiation scattered by the object and providing signals corresponding to the detected radiation; and
 - c. a mask having a plurality of apertures interposed between the object and the detector array.
2. A system according to claim 1, wherein the source of penetrating radiation is an X-ray source.
3. A system according to claim 1, wherein the source of penetrating radiation is a substantially monoenergetic X-ray source.
4. A system according to claim 1, wherein the source of penetrating radiation emits a beam of radiation along a beam opening axis disposed with an orientation with respect to the object such as to illuminate a line on the object.
5. A system according to claim 4, wherein the at least one detector axis has a vector component substantially parallel to the illuminated line.
6. A system according to claim 4, further including a scanning arrangement for moving the beam relative to the object in a direction having a component transverse to the orientation of the beam opening axis.
7. A system according to claim 6, wherein the scanning arrangement includes a swept cathode ray incident upon a stationary anode.
8. A system according to claim 4, further including a conveyance mechanism for moving the object relative to the beam in a direction having a component transverse to the orientation of the beam opening axis.
9. A system according to claim 1, further including a controller for reconstructing the image of the object using the signals corresponding to the detected radiation.
10. A system according to claim 1, wherein the source of penetrating radiation emits pulses having a duration less than the time scale of propagation through the object.

11. A system according to claim 10, further including an electronic circuit for resolving the distance between the source of scattered emission and the at least one array of segmented detectors.
- 5 12. A system according to claim 1, wherein the at least one array of segmented detectors is energy-selective.
- 10 13. A method for analyzing concealed material within an enveloping surface, comprising:
- a. illuminating the enveloping surface with penetrating radiation;
 - b. providing at least one detector array having an aperture mask interposed between the detector array and the enveloping surface such that radiation scattered by the material is incident onto the detector array through the aperture mask;
 - c. measuring the radiation scattered by the material onto the detector array;
 - d. reconstructing an image of the material scattering the radiation; and
 - e. determining physical properties of the concealed material using the radiation scattered by the material and the image of the material.
- 15

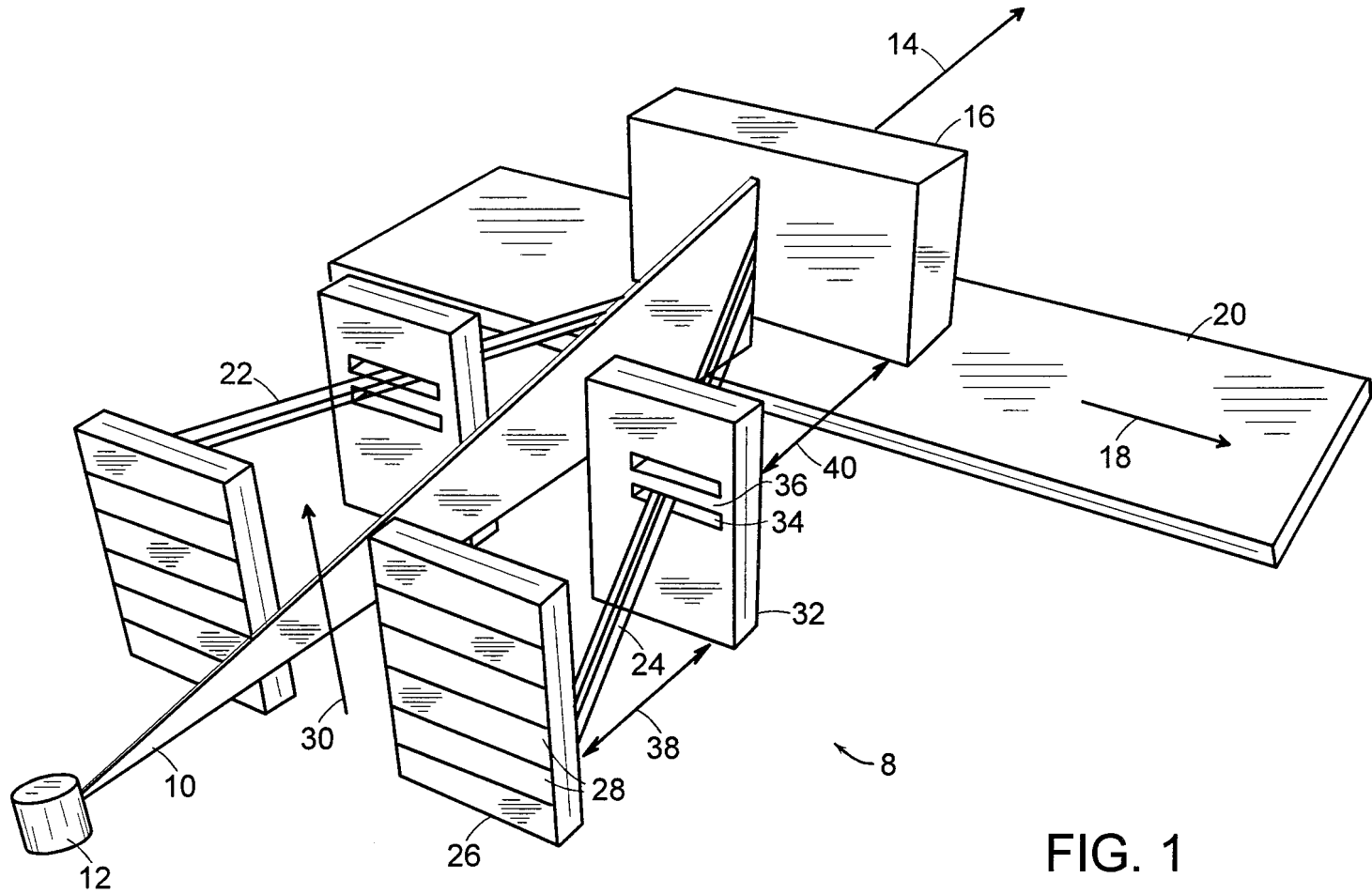

FIG. 1

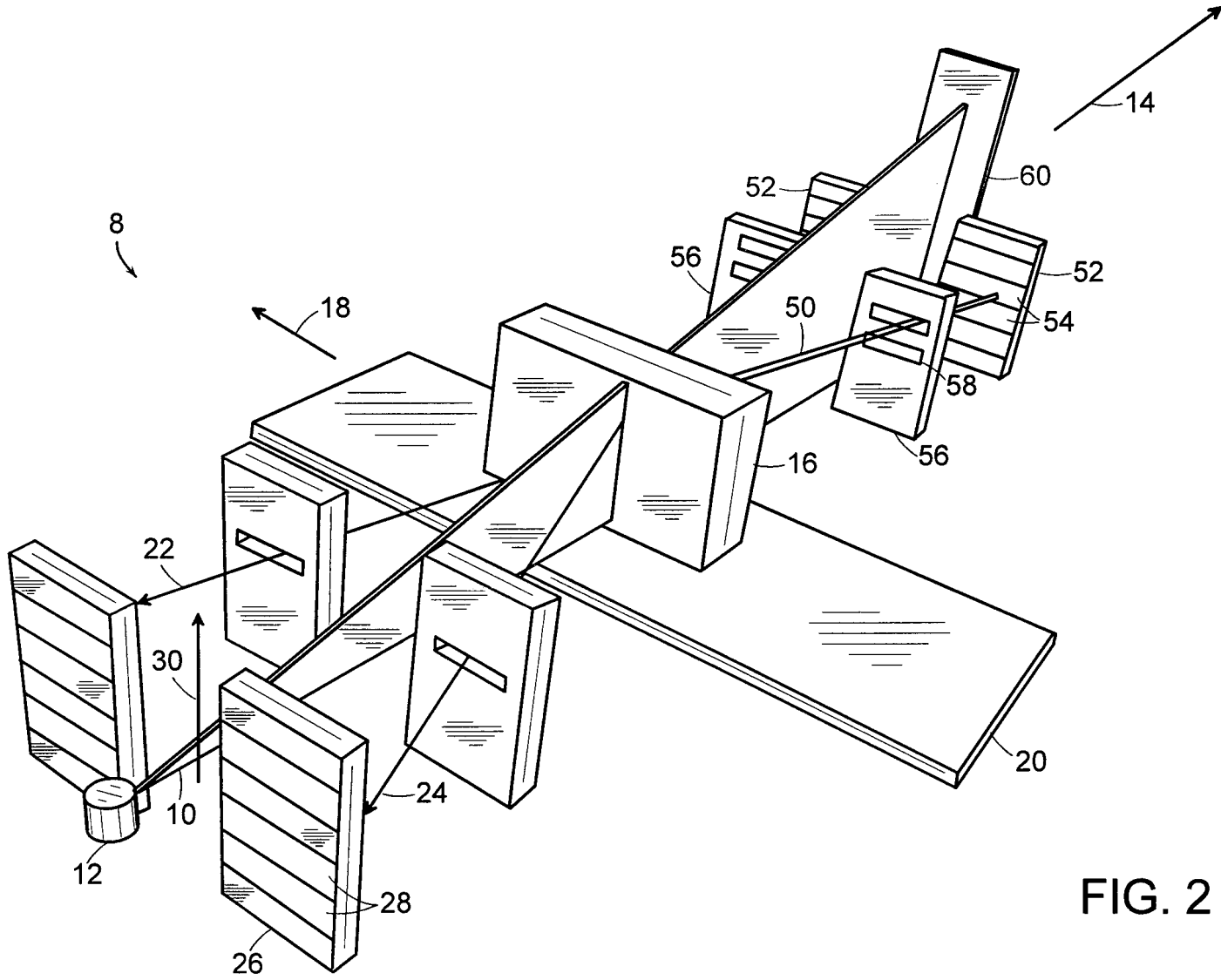

FIG. 2

INTERNATIONAL SEARCH REPORT

International Application No

PCT/US 97/20485

A. CLASSIFICATION OF SUBJECT MATTER IPC 6 G01T1/29 G01V5/00				
According to International Patent Classification (IPC) or to both national classification and IPC				
B. FIELDS SEARCHED Minimum documentation searched (classification system followed by classification symbols) IPC 6 G01T G01V				
Documentation searched other than minimum documentation to the extent that such documents are included in the fields searched				
Electronic data base consulted during the international search (name of data base and, where practical, search terms used)				
C. DOCUMENTS CONSIDERED TO BE RELEVANT				
Category °	Citation of document, with indication, where appropriate, of the relevant passages	Relevant to claim No.		
E	WO 97 45755 A (MASSACHUSETTS INST TECHNOLOGY) 4 December 1997 see abstract see page 6, line 5 - line 15 see page 7, line 25 - line 35 see page 8, line 18 - page 10, line 20 see page 12, line 1 - page 13, line 29 see figures ---	1-3,9,13		
Y	WO 92 02937 A (IRT CORP) 20 February 1992 see abstract see page 5, line 6 - page 6, line 18 see page 8, line 6 - page 9, line 2 see page 22, line 31 - page 23, line 18 see page 28, line 4 - page 30, line 12 see claim 1 see figures --- -/--	1-6,9,13		
<input checked="" type="checkbox"/> Further documents are listed in the continuation of box C.				
<input checked="" type="checkbox"/> Patent family members are listed in annex.				
° Special categories of cited documents :				
<table style="width: 100%; border: none;"> <tr> <td style="width: 50%; border: none; vertical-align: top;"> "A" document defining the general state of the art which is not considered to be of particular relevance "E" earlier document but published on or after the international filing date "L" document which may throw doubts on priority claim(s) or which is cited to establish the publication date of another citation or other special reason (as specified) "O" document referring to an oral disclosure, use, exhibition or other means "P" document published prior to the international filing date but later than the priority date claimed </td> <td style="width: 50%; border: none; vertical-align: top;"> "T" later document published after the international filing date or priority date and not in conflict with the application but cited to understand the principle or theory underlying the invention "X" document of particular relevance; the claimed invention cannot be considered novel or cannot be considered to involve an inventive step when the document is taken alone "Y" document of particular relevance; the claimed invention cannot be considered to involve an inventive step when the document is combined with one or more other such documents, such combination being obvious to a person skilled in the art. "&" document member of the same patent family </td> </tr> </table>			"A" document defining the general state of the art which is not considered to be of particular relevance "E" earlier document but published on or after the international filing date "L" document which may throw doubts on priority claim(s) or which is cited to establish the publication date of another citation or other special reason (as specified) "O" document referring to an oral disclosure, use, exhibition or other means "P" document published prior to the international filing date but later than the priority date claimed	"T" later document published after the international filing date or priority date and not in conflict with the application but cited to understand the principle or theory underlying the invention "X" document of particular relevance; the claimed invention cannot be considered novel or cannot be considered to involve an inventive step when the document is taken alone "Y" document of particular relevance; the claimed invention cannot be considered to involve an inventive step when the document is combined with one or more other such documents, such combination being obvious to a person skilled in the art. "&" document member of the same patent family
"A" document defining the general state of the art which is not considered to be of particular relevance "E" earlier document but published on or after the international filing date "L" document which may throw doubts on priority claim(s) or which is cited to establish the publication date of another citation or other special reason (as specified) "O" document referring to an oral disclosure, use, exhibition or other means "P" document published prior to the international filing date but later than the priority date claimed	"T" later document published after the international filing date or priority date and not in conflict with the application but cited to understand the principle or theory underlying the invention "X" document of particular relevance; the claimed invention cannot be considered novel or cannot be considered to involve an inventive step when the document is taken alone "Y" document of particular relevance; the claimed invention cannot be considered to involve an inventive step when the document is combined with one or more other such documents, such combination being obvious to a person skilled in the art. "&" document member of the same patent family			
Date of the actual completion of the international search	Date of mailing of the international search report			
12 February 1998	24/02/1998			
Name and mailing address of the ISA European Patent Office, P.B. 5818 Patentlaan 2 NL - 2280 HV Rijswijk Tel. (+31-70) 340-2040, Tx. 31 651 epo nl. Fax: (+31-70) 340-3016		Authorized officer Datta, S		

INTERNATIONAL SEARCH REPORT

International Application No

PCT/US 97/20485

C.(Continuation) DOCUMENTS CONSIDERED TO BE RELEVANT

Category	Citation of document, with indication, where appropriate, of the relevant passages	Relevant to claim No.
Y	EP 0 061 547 A (IBM ;IBM UK (GB)) 6 October 1982 see abstract see page 5, line 24 - page 7, line 13 see page 8, line 7 - line 24 see figures ---	1-6,9,13
A	US 5 247 561 A (KOTOWSKI ANDREAS F) 21 September 1993 see abstract see column 2, line 20 - column 5, line 5 see column 7, line 15 - line 50 see figures -----	1-4,6,8, 9,13

INTERNATIONAL SEARCH REPORT

Information on patent family members

i. International Application No

PCT/US 97/20485

Patent document cited in search report	Publication date	Patent family member(s)	Publication date
WO 9745755 A	04-12-97	NONE	
<hr style="border-top: 1px dashed black;"/>			
WO 9202937 A	20-02-92	US 5181234 A	19-01-93
		AU 8437391 A	02-03-92
		IL 99098 A	18-06-96
<hr style="border-top: 1px dashed black;"/>			
EP 0061547 A	06-10-82	JP 1630706 C	26-12-91
		JP 2057679 B	05-12-90
		JP 57166145 A	13-10-82
		US 4435838 A	06-03-84
<hr style="border-top: 1px dashed black;"/>			
US 5247561 A	21-09-93	WO 9508108 A	23-03-95
		AU 4922693 A	03-04-95
<hr style="border-top: 1px dashed black;"/>			