

(19) World Intellectual Property Organization
International Bureau



(43) International Publication Date
2 October 2008 (02.10.2008)

(10) International Publication Number
WO 2008/117109 A1

(51) International Patent Classification:
A61F 13/532 (2006.01)

(21) International Application Number:
PCT/IB2007/003904

(22) International Filing Date:
3 December 2007 (03.12.2007)

(25) Filing Language: Italian

(26) Publication Language: English

(30) Priority Data:
07425178.6 26 March 2007 (26.03.2007) EP

(71) Applicant (for all designated States except US): FAMEC-CANICA.DATA S.P.A. [IT/IT]; Via Aterno, 136, I-66020 Sambuceto di San Giovanni Teatino (Chieti) (IT).

(72) Inventors; and

(75) Inventors/Applicants (for US only): BIANCO, Carlo [IT/IT]; Piazza Rinascita, I-65100 Pescara (IT). POLIDORI, Domenico [IT/IT]; Via Santa Lucia, 33, I-66010 Tollo (Chieti) (IT). DE ANGELIS, Tonino [IT/IT]; Via Cadorna, 56, I-65100 Pescara (IT).

(74) Agents: BOSOTTI, Luciano et al.; Buzzi, Notaro & Antonielli d'Oulx S.r.l., Via Maria Vittoria, 18, I-10123 Torino (IT).

(81) Designated States (unless otherwise indicated, for every kind of national protection available): AE, AG, AL, AM, AT, AU, AZ, BA, BB, BG, BH, BR, BW, BY, BZ, CA, CH, CN, CO, CR, CU, CZ, DE, DK, DM, DO, DZ, EC, EE, EG, ES, FI, GB, GD, GE, GH, GM, GT, HN, HR, HU, ID, IL, IN, IS, JP, KE, KG, KM, KN, KP, KR, KZ, LA, LC, LK, LR, LS, LT, LU, LY, MA, MD, ME, MG, MK, MN, MW, MX, MY, MZ, NA, NG, NI, NO, NZ, OM, PG, PH, PL, PT, RO, RS, RU, SC, SD, SE, SG, SK, SL, SM, SV, SY, TJ, TM, TN, TR, TT, TZ, UA, UG, US, UZ, VC, VN, ZA, ZM, ZW.

(84) Designated States (unless otherwise indicated, for every kind of regional protection available): ARIPO (BW, GH, GM, KE, LS, MW, MZ, NA, SD, SL, SZ, TZ, UG, ZM, ZW), Eurasian (AM, AZ, BY, KG, KZ, MD, RU, TJ, TM), European (AT, BE, BG, CH, CY, CZ, DE, DK, EE, ES, FI, FR, GB, GR, HU, IE, IS, IT, LT, LU, LV, MC, MT, NL, PL, PT, RO, SE, SI, SK, TR), OAPI (BF, BJ, CF, CG, CI, CM, GA, GN, GQ, GW, ML, MR, NE, SN, TD, TG).

Published:
— with international search report

(54) Title: ABSORBING ELEMENT FOR SANITARY PRODUCTS, HAVING EXPANDABLE POCKETS CONTAINING SUPERABSORBENT MATERIAL AND MANUFACTURING PROCESS

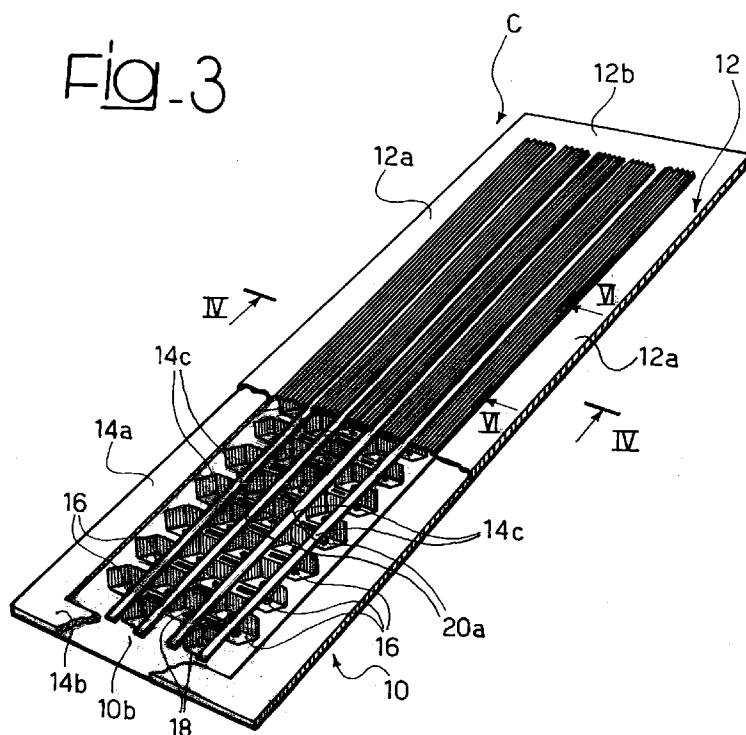

(57) Abstract: An absorbent element for the absorption of body fluids in sanitary articles comprises a first layer of sheet material presenting an array of hollowed formations (16) with respective mouth parts, as well as masses (18) of superabsorbent material that is able to expand as a result of the absorption of body fluid, which are set in the aforesaid hollowed formations (16). A second layer of sheet material (12) is applied on the first layer of sheet material (10) so as to cover the mouth parts of the hollowed formations (16). At least one of the layers of sheet material (10, 12) is permeable to body fluids to enable the body fluids themselves to penetrate into the hollowed formations and be absorbed by the masses of superabsorbent material (18) that expand in the hollowed formations (16), creating a first level of absorption of body fluids. The second layer of sheet material (12) is compliant in an area corresponding to the mouth parts of the hollowed formations (16) and enables further expansion of said masses of superabsorbent material (18) beyond said hollowed formations (16) so as to create a second level of absorption of body fluids. The first layer (10) and the second layer (12) of sheet material are connected to one another

by adhesive formations (14c) that leave the mouth parts of the hollowed formations (16) at least partially free.

WO 2008/117109 A1

ABSORBING ELEMENT FOR SANITARY PRODUCTS, HAVING EXPANDABLE POCKETS CONTAINING SUPERABSORBENT MATERIAL AND MANUFACTURING PROCESS

5 Field of the invention

The invention relates to absorbent sanitary articles and specifically regards an absorbent element for an article of this type.

10

Description of the related art

The term "absorbent sanitary articles" indicates in general articles such as, for example, diapers for
15 babies and small children, sanitary towels for incontinence, pantie-liners for ladies, tampons and the like, designed for absorbing body liquids, being preferentially located in the perineal region of the user.

20

As schematically illustrated in Figure 1 of the attached plate of drawings, these articles usually have a stratified structure comprising an outer sheet B impermeable to liquids (commonly referred to as "backsheet"), an inner sheet T permeable to liquids
25 (commonly referred to as "topsheet"), designed to be set in contact with the skin, and an absorbent central insert or core C, which has the function of capturing and storing body liquids. In particular, in the representation of Figure 1 there is recognizable the
30 typical hourglass configuration of an absorbent sanitary article that can be worn as pants, such as precisely a diaper or a sanitary towel, provided with labels E for closing on the waist.

As is well known to persons skilled in the art,
35 over the course of the years, around this basic

structure practically infinite integrations and variants of structure have been developed. These integrations and variants are not, however, of specific importance for the subject treated herein, which is essentially the absorbent core C.

In the first industrially produced diapers appearing on the market at the end of the fifties, the absorbent core C was basically made up of so-called cellulose fluff with different shapes and specific weight (weight per unit surface). Subsequently, the tendency has developed of adding to the cellulose fluff superabsorbent granular materials with a high capacity for retaining liquids.

Said superabsorbent materials are known by different terms, such as, for example, SAP (Super Absorbent Polymer) or AGM (Absorbent Gelling Material). In the majority of cases, these are hydrogelling materials capable of absorbing and capturing the liquid in a practically stable way.

By way of reference, one gram of cellulose fluff is capable of absorbing 8-10 g of 0.9% saline solution but withholds only an extremely modest fraction thereof, typically 2-3 g.

Instead, one gram of superabsorbent material is capable of absorbing approximately 50 g of saline solution and of withholding approximately 30 g thereof after centrifugation (according to the EDANA 441.1-99 method) or else approximately 22 g under a load of 0.7 psi (according to the EDANA 442.1-99 method).

In view of these characteristics, the idea of creating an absorbent core for sanitary articles, constituted principally, if not exclusively, of superabsorbent material, appears certainly attractive.

In this connection, it should, however, be noted that the fluff has the function both of acquiring and

conveying the liquid within the absorbent core. The superabsorbent material has instead, more than anything else, the function of retaining the liquid. For this reason, superabsorbent materials were initially used at low concentrations (70% of fluff, 30% of superabsorbent material). It has in fact been found that concentrations higher than 40% can lead to the phenomenon referred to as "gel-blocking": by swelling, the granules of superabsorbent material create a barrier to the liquids, slowing down the capacity for further acquisition of liquids, until said capacity is practically lost.

This drawback can be overcome at least in part by using superabsorbent materials of a permeable type only recently available on the market. Alternatively, it is possible to intervene on the spatial distribution of fluff/superabsorbent material, or else add to the core materials with characteristics of acquisition and distribution of liquids. These solutions enable the use of concentrations of superabsorbent materials of up to approximately 60 wt% with respect to the core as a whole.

Various patent documents illustrate the possibility of creating an absorbent core without fluff of a traditional type (usually cellulose) by replacing the cellulose fibres with different materials (for example, cellulose acetate). Examples of documents of this kind are the documents US-A-2003/0208174, US-B-6 068 620, and US-B-6 832 905. There also exist patent documents that teach how to obtain absorbent cores constituted in a practically exclusive way by superabsorbent material and extracts of materials of various nature. In this connection, documents may be considered, such as US-A 4 578 078, US-A 4 600 458, US-

A-4 658 914, US-A-4 681 577, US-A-4 685 914, US-A-5 643 238, US-A-5 938 650 or WO-A-2005/004939.

Albeit presenting features of applicational advantage, the solutions described in said prior documents cannot be considered altogether satisfactory.

In effect, to achieve altogether satisfactory performance, an absorbent core with a base of superabsorbent material should correspond to the ideal model represented in Figure 2 of the annexed plate of drawings: this consists of a regular lattice of granules 10 of superabsorbent material separated by a "means" X that should be able to:

- withhold the granules 10 in the position assigned to them within the lattice, preventing any undesirable displacement thereof when the article is handled and worn;

- acquire the body liquid and transfer it completely to the granules 10, enabling the granules 10 themselves to absorb the liquid and undergo swelling;

- oppose no resistance to the swelling of the granules 10: rather, the "means" X should in effect disappear as the granules 10 swell in such a way as to cause, once absorption of the liquid is completed, the absorbent core to be constituted exclusively by the swollen granules 10; and

- continue to acquire liquid during the process of swelling of the granules 10, transferring it through the entire mass of absorbent material, preventing part of this mass from failing to absorb liquid and hence remaining unused.

Object and summary of the invention

The object of the invention is to provide an absorbent element that approaches the ideal model

outlined previously much more closely than occurs for the solutions according to the prior art, to which reference was made previously.

According to the present invention, said object is achieved thanks to an absorbent element for sanitary articles having the characteristics recalled specifically in the ensuing claims. The invention also relates to a corresponding sanitary article and to the method of production of the absorbent element.

The claims form an integral part of the disclosure of the invention provided herein.

Brief description of the annexed drawings

The invention will be described, purely by way of non-limiting example, with reference to the annexed figures of drawing, wherein:

- Figures 1 and 2 have already been described previously;
 - Figure 3 is a perspective view, partially cutaway, of an absorbent element of the type described herein;
 - Figure 4 is a cross section according to the line IV-IV of Figure 3;
 - Figure 5 is an enlarged view of the part of Figure 4 indicated by the arrow V;
 - Figure 6 is a cross section according to the line VI-VI of Figure 3;
 - Figures 7 and 8 are two views substantially homologous to that of Figure 6, which represent operation of the absorbent element described herein;
 - Figure 9 is a schematic illustration of successive possible steps of a method for the production of the absorbent element described herein;
- and

- Figure 10 is a schematic illustration of the structure of a device for producing the absorbent element described herein.

5 Detailed description of exemplary embodiments of the invention

As in the preceding Figure 1, in Figure 3 the reference C designates as a whole an absorbent element that can be used within a sanitary article of the type
10 of the ones referred to in the introductory part of the present description.

In the exemplary embodiments represented herein, the element C basically assumes the form of a flattened body having an overall rectangular shape. This
15 conformation is usable, for example, in the case where the element C is designed to be inserted in a diaper or else in a sanitary towel for incontinence. The rectangular shape is not, however, in any way imperative, in particular for applications in different
20 products, such as, for example, sanitary pantie-liners for ladies, articles in which there is usually preferred, for the absorbent core, a bone shape or an hourglass shape, which is more conformable to the anatomy of the person wearing the article. The ensuing
25 description will on the other hand enable an easier understanding of how the solution described herein is suited to being used according to a wide range of geometries.

As better appreciated from the cross-sectional
30 view of Figure 4, the absorbent element C has a layered structure comprising two laminar elements or layers of sheet material 10 and 12 connected to one another (according to modalities better described in what follows) by a layer of adhesive 14, constituted for

example, by a hot-melt glue, which is widely used in the production of sanitary articles.

At least one, and preferably both of the layers 10 and 12 are permeable to the body fluids that the element C is designed to absorb. In a currently preferred embodiment, the layers of sheet materials 10 and 12 are constituted by non-woven fabric consisting of polypropylene and a mixture of fibres with a specific weight (weight per unit area) in the region of 10 g/m² to 30 g/m².

Materials of this type are widely used in the production of sanitary articles. For reasons of simplicity of description, in what follows reference will be made herein to the layer 10 and to the layer 12 as "bottom" layer and "top" layer, respectively. These terms are used purely by way of reference and are not to be interpreted as in any way limiting the scope of the invention: the absorbent element C is suited in fact to being used according to a practically indifferent orientation.

The intention in saying that -- *at least one* -- of the layers 10 and 12 is permeable to the body fluids that are to be absorbed by the absorbent element is to point out the possibility of the other of said layers (for example, the "bottom" layer 10) also being impermeable to body fluids. In this way, the impermeable layer is suited to facing the outside of the absorbent article and to co-operating with the backsheet in the function of retention of body fluids, or else to constituting itself the backsheet.

The bottom layer of sheet material 10 basically presents as an alveolated layer, in the sense that, with the possible exception of two side bands 10a and two head bands 10b (kept preferentially smooth in order to ensure firm connection with homologous bands 12a and

12b of the top sheet 12 for creating a firm lateral grip of the element C), in the layer 10 there are present hollowed or well-like formations 16, obtained according to criteria described more fully in what follows.

In a preferred way, and as may be appreciated better from the perspective view of Figure 3, the aforesaid hollowed or well-like formations 16 preferentially assume the form of a continuous array of hexagonal cells having (these data have of course a purely orientative value) a depth of approximately 1-10 mm and diametral dimensions in the region of 5-30 mm.

This "honeycomb" conformation constitutes a preferential solution, which optimizes the ratio between the part of area of the layer 10 occupied by the cells 16 and the total area of the layer 10.

This conformation, and in particular the fact that these hollowed formations (in brief, cavities) 16 are hexagonal in shape (set according to an array of cells strictly penetrating one another according to a honeycomb arrangement) is not, however, imperative. The cavities or wells 16 could in fact have any shape (for example, with a circular-mouth profile) and/or be set at a certain distance from one another and/or form an array that, unlike the continuous array illustrated in the annexed plate of drawings, has discontinuities, i.e., areas of the layer 10 where cavities or wells 16 are not present, possibly with the cavities or wells 16 localized only in an area corresponding to the central part of the element C.

Again, whilst in the example illustrated herein the distribution of the cavities or wells 16 is uniform, both as regards the dimensions and as regards the distribution of the cavities or wells 16, non-

uniform distributions are certainly included in the scope of the invention, namely, for example, distributions in which:

5 - the cavities or wells 16 have larger dimensions at the centre of the element C and smaller dimensions at the margins of the element C; and/or

10 - the density (i.e., the number per unit surface) of the cavities or wells 16 is different at the centre of the element C from at the margins of the element C; for example, with a higher number at the centre than at the margins.

Those of skill in the art will appreciate that non-uniform distributions of this kind are designed to take into account the fact that the discharge of body fluids is localized usually in an area corresponding to an "deposition area" located in the proximity of the centre of the element C, possibly with morphologies that are different according to the sex of the user.

20 Within the cavities or wells 16 (usually within all of the cavities or wells 16 made in the layer 10), respective amounts 18 of material are present with capacity to absorb body fluids: these are precisely materials known as SAP (Super Absorbent Polymer) or AGM (Absorbent Gelling Material) that are able to withhold, 25 by swelling, large quantities of water and hence of body liquids.

Orientatively (with reference to the cell dimensions indicated previously by way of example), each amount 18 can be constituted for example by 0.05- 30 0.40 g of superabsorbent material. Each of the amounts or masses 18 of superabsorbent material is usually constituted by a certain amount of granules of this material. It is usually preferred that the granules of superabsorbent material should not be deposited freely 35 within the corresponding cavity or well 16 but should

be withheld therein by a certain amount of glue 20
designed to bestow a certain coherence upon the amount
of superabsorbent material. This is usually a
hydrosoluble glue, for example the glue available under
5 the commercial name of Cycloflex, manufactured by the
company National Starch (USA). In contact with body
liquids, said hydrosoluble glue loses at least in part
its characteristics of adhesiveness, so that when the
element C starts to absorb liquid, the mass of
10 superabsorbent material 18 detaches from the wall of
the cavity or well 16 in which it is located and can
thus be freer to expand as a result of the absorption
of liquid, co-operating, with the homologous masses 18
that are in the other cavities or wells 16, in the
15 creation of a lattice with anti-collapsing function.

As will be more fully described in what follows,
the hydrosoluble glue can also perform the function of
keeping the cavities or wells 16 closed as long as the
element C remains dry.

20 In the foregoing description it has at least been
implicitly assumed that the masses 18 of superabsorbent
material have the same characteristics of absorption
and are dosed in a uniform way in the various cavities
or wells 16. However, the invention also encompasses
25 the use of masses 18 with differentiated
characteristics of absorption (for example, absorption
that is faster or more deferred over time) and/or the
recourse to non-uniform dosages in the various cavities
or wells 16 (i.e., causing the masses 18 of
30 superabsorbent material to be distributed in different
amounts in different areas of the element), the
foregoing having the purpose of modulating in time
and/or in space the qualities of absorption of the
various areas of the element C.

Joint observation of Figures 3 and 4 will highlight the morphology of the layer of glue 14 that connects the layers 10 and 12. This layer comprises:

- two side strips 14a that connect to one another
5 the layers 10 and 12 in areas corresponding to the side bands 10a and 12a; and

- two head strips 14b that connect to one another
the layers 10 and 12 in areas corresponding to the head bands 10b and 12b.

10 In addition to the aforesaid side strips and head strips, designed to create an external line of sealing between the two layers of sheets 10 and 12 extending along the border of the element C, the layer of glue 14 also comprises a plurality of strips 14c, which extend,
15 set apart from one another (for example, by a distance comprised between a minimum of 1 mm and a maximum of 30 mm) for connection of the layers 10 and 12 in the area where the cavities or wells 16 are located.

The glue of the layer 14 is a stable, non-
20 hydrosoluble, glue, such as typically a glue of a hot-melt type. The fact that the strips 14c (illustrated herein as continuous, but which may consist also of discrete stretches) are set apart from one another is aimed at preventing the mouth parts of the cavities or
25 wells 16 - on which the layer 12 extends to provide a covering - from being undesirably occluded by the glue. For example, with the values of distance between the strips 14c indicated above, it is possible to proceed in such a way that, according to the shape and the
30 dimensions of the mouth part of the cavities or wells 16, the mouth surface of said cavities or wells 16 is kept free from the glue 14c for a fraction that ranges from one third of the surface to the entire surface (i.e., from 33% to 100%) of said surface.

The configuration illustrated herein, with the presence of strips of glue 14c oriented in the direction of principal extension of the element C, constitutes just one from among the various possible solutions that enable the desired effect to be achieved (distributed connection of the layers 10 and 12, without producing the complete occlusion of the mouth parts of the cavities or wells 16).

The same result could be obtained, for example, using strips of glue that extend not "lengthwise", as in the case of the strips 14c that may be seen in Figure 3, but in a direction exactly orthogonal (hence "crosswise") with respect to the element C.

Other alternative solutions can envisage strips of glue extending in a direction inclined with respect to the element C or else according to a zigzag path, or else continuous or discontinuous formations of glue applied according to different geometrical configurations, such as for example diamond shapes or paths that reproduce at least locally the paths of the mouth parts of the cavities or wells 16.

Again, the surface of distribution of the glue of the layer 14 (whatever the shape) can be non-uniform on the surface of development of the element C so as to bestow upon the element C characteristics of flexibility and/or deformability differentiated from area to area in order to improve the qualities of anatomical adherence to the body of the user.

The configuration illustrated herein by way of example (strips of glue 14c oriented in the direction of principal extension of the element C) is currently preferred for at least two reasons:

- it allows (or, at least, does not appreciably hinder) the possibility of the element C to bend in a transverse direction according to a general channel-

like configuration: this configuration facilitates the collection and containment of the fluids, proving likewise more effective from the standpoint of the anatomical conformability of the element C and of the article that comprises it;

- it induces setting-up, in the area of transition or interface between the layers 10 and 12, of channels of diffusion of the liquid from the centre (depot area) towards the ends of the element C.

In addition to presenting the side bands 12a and head bands 12b kept preferentially smooth (to facilitate the adhesive connection with the side bands 10a and head bands 10b of the layer 10), the layer 12 is a layer with characteristics of compliance.

These characteristics can be intrinsic ones of the sheet material constituting the layer 12.

Usually, these characteristics are, however, obtained by subjecting said material to a process such as to bestow thereon, or else enhance, said characteristics.

In a possible embodiment, this result is obtained by subjecting the central portion of the top sheet 12 - hence with the exclusion of the bands 12a and 12b - to an operation of "activation" i.e., of weakening such as to weaken/break the connections between the fibres of the non-woven fabric of the layer 12 in a transverse direction with respect to the element C (i.e., in a transverse direction with respect to the lines of glue 14c).

The term "activation" recalls the fact that such a treatment is commonly carried out in elasticized non-woven materials in order to make them "active", i.e., more easily extendible elastically.

Further modalities of treatment, such as to enable, in an area corresponding to the aforesaid

central part, the sheet 12 to present characteristics of compliance, are substantially within the reach of the person skilled in the art: for example, the material of the layer 12 could be subjected to a treatment of (micro)pleating in a transverse and/or longitudinal direction with respect to the element C.

The general pleated pattern of the portions 12c that may be seen in Figures 4 to 8 of the annexed plate of drawings must then be interpreted as a figurative representation of the characteristic of compliance, without specific reference to the modalities with which said characteristic is obtained.

Whatever the specific solution adopted, in an area corresponding to the portions 12c, where the layer 12 is not connected adhesively to the bottom layer 10 by the strips of glue 14c, the layer 12 can deform in a direction opposite with respect to the mouth parts of the cavities or wells 16.

Albeit without wishing to attribute a binding character to this quantitative datum, the degree of compliance recommended for the portions 12c is such that, yielding under the thrust of the masses 18, the portions 12c are subjected to a linear extension in a ratio from approximately 1.5:1 to approximately 3:1 with respect to the initial value; i.e., yielding under the thrust of the masses 18, the portions 12c are able to lengthen up to twice or three times with respect to the adjacent areas of the layer 12.

This capacity for deformation of the top layer 12 is designed to enable the layer 12 to deform when, as a result of the gradual absorption of the body liquids, after occupying the respective cavities 16 entirely, the masses of superabsorbent material 18 tend to expand (as schematically illustrated with a dashed line in

Figure 5) beyond the mouth edges of the cavities 16 themselves.

The striplike distribution 14c (or, in general, discontinuous distribution) of the glue 14 is precisely
5 designed to enable free expansion of the aforesaid masses of superabsorbent material 18. By swelling as a result of the absorption of the liquid that penetrates into the element C through at least one or preferably both of the layers 10 and 12, after completely or
10 practically completely occupying the respective cavity or well 16, the masses 18 are hence free to press against the layer 12, without finding in the glue 14 an appreciable obstacle to the further deformation.

The masses of superabsorbent material 18 press
15 against the layer 12, which, owing to the presence in the compliant regions 12c, yields under the thrust of the masses 18. The phenomenon of expansion of the superabsorbent masses 18 (and hence the absorption of fluid) can thus take the form of:

- 20 - a "first level", corresponding to the filling of the respective cavity or well 16; and
- a "second level", represented by the further step of expansion of the masses 18 beyond the mouth edge of the respective cavity or well 16.

25 As already mentioned previously, the use of hydrosoluble glue can be extended to the function of keeping the cavities or wells 16 closed as long as the element C remains dry. In particular (usually concomitantly with the application of the glue 20 that
30 withholds the masses of superabsorbent material 18), further formations 20a of hydrosoluble glue can be applied on the "bridges" that separate adjacent cavities or wells 16 in the longitudinal direction of the element C: see in this connection, Figure 3.

As may be appreciated better from the cross-sectional view of Figure 6, as long as the element C is dry (i.e., before absorption of body fluids starts), the portion of layer 12 set covering each cavity or well 16 in effect closes said cavity or well 16, which - like the mass of superabsorbent material 18 contained therein - is hence:

- separated from the adjacent cavities or wells 16 in the direction transverse to the element C by the strips of (permanent) glue 14c; and

- separated from the adjacent cavities or wells 16 in the longitudinal direction of the element C by the formations of (hydrosoluble and hence non-permanent) glue 20a.

When the element C starts to absorb fluid, the formations of hydrosoluble glue 20a lose their adhesive power. The layer 12 then tends to detach from the layer 10, where before the two layers 10 and 12 were connected together by the glue 20a (see Figure 7). This detachment occurs under the thrust of the superabsorbent material 18, which expands. In this way, at the "second level" of expansion, the superabsorbent masses 18 (which, at the "first level" of expansion, are confined in their cavities 16) can instead overflow into the adjacent cavities 16 in the longitudinal direction of the element C, and this also to quite a considerable extent, as will be better appreciated from Figure 8.

By way of orientative example, the aforesaid mechanism of two-level expansion enables the masses of superabsorbent material to expand in a ratio such that, setting the total volumetric expansion of the superabsorbent material ideally at 100, approximately 70-90% of the expansion is obtained at the "first level" (i.e., within the cavities or wells 16), whilst

the remaining 30-10% is obtained at the "second level" of expansion, after failure of the bond established by the formations of glue 20a.

It will be appreciated in this connection, that:

5 - above all in the case where the cavities or wells 16 are obtained according to a dense honeycomb network of hexagonal cells, when the masses of superabsorbent material 18 are completely expanded, the volume of the element C is constituted in a practically
10 integral way (except for the side bands and the head bands) by superabsorbent material that has absorbed body liquids;

 - also when the process of absorption of the liquid occurs at the second level, the masses 18
15 continue to be anchored in the respective cavities or wells 16; hence, they do not collapse against one another (for example, accumulating by gravity in an undesirable way at the centre of the crotch element C) and maintain a high exposure to the liquid arriving,
20 minimizing the onset of phenomena of gel blocking.

Figure 9 is a schematic illustration of the sequence of execution of the various operations that lead to creating the absorbent element C described previously.

25 In particular, the reference 100 designates the workstation in which, starting from a sheet of smooth material (for example, non-woven fabric with a substance of approximately 10-30 g/m²) formation of the cavities or wells 16 is carried out. For this purpose,
30 it is envisaged that the sheet will be made to pass over a forming mould, basically constituted by a mesh 102 provided with apertures having a profile (for example, hexagonal) that reproduces the mouth edges of the cavities or wells 16.

The sheet material 10 is pressed against the aforesaid forming mesh 102 by an impression roller 104 provided with punches, which force the material 10 into the cavities of the mesh 102 to form the cavities or wells 16. The process of forming can be facilitated by the presence, on the side of the mesh 102 opposite to the material 10 and to the roller 104, of a level of subatmospheric pressure produced by a suction source 106.

The depth of the cavities 16 present in the mould 102 (for example, 10 mm) enables creation of a correct shaping of the cavities or wells 16, preventing any undesirable tearing or perforation of the sheet material 10 (which can present non-isotropic characteristics of tensile strength in a longitudinal direction and in a transverse direction), in particular when a polygonal profile, for example a hexagonal profile, is bestowed upon the cavity 16.

The alveolated layer 10 thus formed advances then towards a station 114, in which into the cavities or wells 16 are poured, in a way in itself known, the masses of hydrosoluble glue 20. The same station 114 can also provide, once again in a known way, for depositing of the glue formations 20a.

Once again with reference to Figure 9, the reference 108 designates a workstation where the masses of superabsorbent material 18 are metered within the cavities 16. In a preferred way, the dosing station 108 comprises a container or tank 110 that contains the powdered superabsorbent material and functions as vibration doser co-operating with a dosing "wheel" 112. This is basically a drum, the outer surface of which is provided with dosing holes distributed according to a geometrical pattern similar to the geometrical

distribution of the cavities or wells 16 made in the sheet material 10.

Loading of the powdered superabsorbent material on the dosing roller 112 and delivery of the material into
5 the cavities or wells 16 occur preferentially using a pneumatic mechanism.

In particular, the path of rotation of the outer surface of the dosing roller 112 envisages that, in a region of loading, where the holes of the dosing roller
10 112 currently facing towards the container 110 are located, the holes of the dosing roller 112 are brought to a level of subatmospheric pressure and are filled with superabsorbent material sucked in from the container 110.

15 The condition of subatmospheric pressure is maintained in the holes in order to prevent, with the possible aid of a containment strip 115, the superabsorbent material from coming out of the holes of the dosing roller.

20 When, as a result of the movement of rotation of the roller 112, the holes previously charged with superabsorbent material are set facing downwards, towards the sheet material 10, a jet of air coming from within the roller 112 expels, from the holes, the
25 powdered superabsorbent material, which is thus deposited in the cavities or wells 16 of the sheet material 10.

Again as a result of the rotation of the roller 112, once the superabsorbent material contained in the
30 holes has been expelled, the holes return towards the top to reach again the position in which they face the container or tank 110. During said movement of return towards the container 110, the holes undergo cleaning with a flow of ionized and heated air in order to
35 prevent any contamination.

Usually associated to the metering roller 112 are sealing elements acting both in the axial direction and in the tangential direction in order to prevent the powdered superabsorbent material from being dispersed and being drawn beyond the area of depositing in the cavities or wells 16. The axial sealing elements can be constituted by pressurized slots provided on the vertical shoulders of the overlying container 110, with the possible addition of suction holes that capture any granules that may have leaked out. In the tangential direction, the seal is constituted preferentially by scraping elements that function substantially as doctor blades in regard to the outer surface of the dosing roller. These scraping elements can have associated to them jets of air and suction cavities for collecting any grains of powder of superabsorbent material that may have leaked out.

The reference number 116 designates the workstation that carries out the so-called operation of "activation" of the top-sheet material 12, designed to cause the top layer 12 to be compliant under the thrust exerted by the masses of superabsorbent material 18 so as to enable expansion of the masses 18 at the "second level".

In a known way, the station 116 comprises two counter-rotating rollers with complementary circumferential grooves that grip between them the material of the layer 12 and engage one another with an interval or gap that can be adjusted with precision so as to create the desired action of "activation". At least one of the aforesaid rollers has smooth end bands and discontinuities in the grooves such as to cause activation of the layer 12 not to occur in areas corresponding to the side bands 12a and head bands 12b (Figure 3), where it is desired that the material of

the layer 12 should conserve its initial toughness. The station 116 usually also applies a longitudinal tensile force on the sheet material 12.

The references 118 and 120 designate two stations
5 for application of glue (for example, of a hot-melt kind) of a known type, designed to deposit the formations of glue 14a, 14b and 14c on the layers 10 and 12.

The presence of two workstations designed to
10 operate distinctly on the two layers of sheet material 10 and 12 is not in itself imperative. The glue 14 could be applied also on just one of said layers of sheet material with a view to their subsequent coupling together. Figures 9 and 10 refer to a preferential
15 embodiment, where it is envisaged that the station 118 applies the external side strips 114a and head strips 14b on the bottom layer 10, whilst the unit 120 applies the strips 14c on the sheet material of the layer 12.

Of course, the modes of application of the glue
20 can be modified according to the needs, in particular when the overall geometry of the element C changes. This applies also to the hydrosoluble glue: for example, the formations 20a could be applied (instead of in the station 114, as hypothesised herein)
25 concomitantly with the strips 14c.

After receiving the layer or layers of glue 14, the two layers 10 and 12 are superimposed on one another, causing them to pass into a pressing station 126 (for example a roller pressing station), which
30 presses the layers 10 or 12 against one another in an areas corresponding to the strips of glue 14a, 14b and 14c, which, solidifying, connect the two layers 10 and 12 together, bestowing final coherence on the element C.

The semifinished product thus obtained is then made to advance towards a segmentation station 128, which segments the chain of elements C so far connected to one another, acting in the end areas 10b and 12b
5 connected to one another by the strips of glue 14b, thus giving rise to individual elements C.

The view of Figure 10 (where devices and components that are identical or equivalent to the ones already described in relation to Figure 9 are
10 designated by the same reference numbers) highlights how - according to a particularly preferred embodiment - a fair part of the treatment stations described previously are preferably distributed around a carousel structure 200 substantially resembling a wheel or
15 roller, the outer surface of which defines a winding path first for the sheet constituting the layer 10, then for the layer 12, which is applied against the shaped layer 10 to form the cavities or wells 16 and is filled with the masses of superabsorbent material 18,
20 and finally for the semifinished product resulting from the coupling of the layers 10 and 12.

Advantageously, the wheel or roller constituting the carousel structure 200 has an outer surface perforated in a way complementary to the cavities or
25 wells 16 and is provided with one or more internal cavities that can be brought to a different level of pressure according to the stretch of winding path considered.

In this way, the outer surface of the carousel
30 structure 200 is able to perform the function of the perforated mould for the formation of cavities or wells 16 (mould 102 of Figure 9) and, in general, to ensure a firm retention of the layer 10 (subsequently coupled to the layer 12), this in so far as the cavities or wells
35 16 continue to be received in the holes of the outer

surface of the carousel structure 200 until the final composite product (obtained in the station 126, substantially constituted by a roller that presses the layer of sheet material 12 against the layer of sheet material 10 with interposition of the layer of glue 14) is separated, as represented by the reference number 130, from the surface of the carousel structure 200 by extracting the cavities or wells 16 from the holes of the outer surface of the structure 200 itself.

Of course, without prejudice to the principle of the invention, the details of construction and the embodiments may vary, even to a marked extent, with respect to what is illustrated herein purely by way of non-limiting example, without thereby departing from the scope of the invention, as defined by the annexed claims. This applies in particular, but not exclusively, to the possibility of replicating the solution described herein so as to give rise to a multiple absorbent element C constituted by the superposition of a number of elements of the type described and illustrated herein, possibly comprising superabsorbent materials with differentiated characteristics of absorption (for example, an absorption that is faster or more deferred over time). Such a multiple element can be simply constituted by a layer 10 of the type described herein, the alveolated structure of which is used, exploiting the cavities present on both faces of the layer 10 for charging with superabsorbent material (if necessary, with differentiated characteristics of absorption on the opposite faces), and by two layers 12 - once again of the type described herein - applied for covering the cavities on the two opposite faces of the layer 10.

CLAIMS

1. An absorbent element for the absorption of body fluids in sanitary articles, comprising:
- a first layer of sheet material (10) presenting
5 an array of hollowed formations (16) with respective mouth parts;
 - masses (18) of superabsorbent material expandable as a result of the absorption of body fluid, which masses are arranged in said hollowed formations
10 (16); and
 - a second layer of sheet material (12), applied on said first layer of sheet material (10) covering the mouth parts of said hollowed formations (16);
and wherein:
- 15 - at least one of said first and second layers of sheet material (10, 12) is permeable to body fluids to enable the body fluids themselves to penetrate into said hollowed formations (16) and be absorbed by said masses of superabsorbent material (18) that expand in
20 said hollowed formations (16); and
- said second layer of sheet material (12) is compliant in an area corresponding to the mouth parts of said hollowed formations (16), enabling the further expansion of said masses of superabsorbent material
25 (18) beyond said hollowed formations (16).
2. The element according to Claim 1, in which said first (10) and second (12) layers of sheet material are connected to one another by adhesive formations (14c);
30 said adhesive formations (14c) leaving at least partially free the mouth parts of said hollowed formations (16).
3. The element according to Claim 2, in which said
35 adhesive formations (14c) leave the mouth parts of said

hollowed formations (16) free for a fraction that ranges from 33% to 100% of the area of said mouth parts.

5 4. The element according to any one of Claims 1 to 3, in which both of said layers of sheet material (10, 12) are permeable to said body fluids.

10 5. The element according to any one of the preceding claims, in which said first layer of sheet material (10) is exempt from said hollowed formations (16) in an area corresponding to at least part (10a, 10b) of its border.

15 6. The element according to any one of the preceding claims, in which said hollowed formations (16) form a continuous array in said first layer of sheet material (10).

20 7. The element according to any one of the preceding claims, in which said hollowed formations define a uniform array.

25 8. The element according to any one of the preceding claims, in which said hollowed formations are hexagonal in shape, so that said array has a honeycomb appearance.

30 9. The element according to any one of the preceding claims, in which at least one, and preferentially both, of said first layer (10) and said second layer (12) of sheet material is made of non-woven fabric.

10. The element according to any one of the preceding claims, in which, at least in an area corresponding to the mouth parts of said hollowed formations (16) of said first layer of sheet material, said second layer of sheet material (12) present areas (12c) that are more compliant than the adjacent areas of said second layer of sheet material (12).

11. The element according to Claim 10, in which said areas (12c) of greater compliance are weakened or pleated areas.

12. The element according to either Claim 10 or Claim 11, in which said areas (12c) of greater compliance have a capacity of extension increased by 1.5 to 3 times with respect to the adjacent areas of said second layer of sheet material (12).

13. The element according to any one of the preceding Claims 10 to 12, in which said second layer of sheet material (12) is exempt from said areas (12c) of greater compliance in an area corresponding to at least part (12a, 12b) of its border.

14. The element according to Claim 2, in which, at least in areas corresponding to said hollowed formations (16), said adhesive formations (14c) are in the form of strips.

15. The element according to Claim 14, in which said striplike adhesive formations (14c) extend in a longitudinal direction with respect to the element (C).

16. The element according to Claim 14 or Claim 15, in which said striplike adhesive formations (14c) are set apart from one another by gaps.

5 17. The element according to Claim 16, in which said gaps have a width of between 1 and 30 mm.

18. The element according to Claim 2, in which said adhesive formations (14c) consist of hot-melt
10 glue.

19. The element according to any one of the preceding claims, in which said masses (18) of superabsorbent material are anchored in said hollowed
15 formations (16) by a hydrosoluble adhesive (20) soluble by said body fluids.

20. The element according to any one of the preceding claims, comprising hydrosoluble adhesive
20 formations (20a) that connect said first and second layers of sheet material (10, 12) so as to separate hollowed formations (16) set adjacent to one another; said hydrosoluble-adhesive formations (20a) being soluble by said body fluids to enable said further
25 expansion of said masses of superabsorbent material (18) beyond said hollowed formations (16).

21. The element according to Claim 2 and Claim 20, in which said first and second layers of sheet material
30 (10, 12) are connected both by stable adhesive formations (14c) that leave the mouth parts of said hollowed formations (16) at least partially free and by said hydrosoluble adhesive formations (20a).

22. The element according to any one of the preceding claims, in which said masses (18) of superabsorbent material are distributed in different amounts in different areas of the element.

5

23. The element according to any one of the preceding claims, in which, following absorption of body fluids, said masses of superabsorbent material (18) expand:

- 10 - for 70-90% of their overall volume of expansion, in said hollowed formations (16); and
- for the remaining 30-10% of their overall volume of expansion beyond said hollowed formations (16).

15 24. The element according to any one of the preceding claims, comprising:

- a said first layer of sheet material (10) presenting arrays of hollowed formations (16) with respective mouth parts on both of its opposite faces,
- 20 said hollowed formations (16) receiving masses (18) of superabsorbent material that is able to expand as a result of the absorption of body fluid; and
- a pair of said second layers of sheet material (12) applied on the opposite faces of said first layer
- 25 of sheet material (10) so as to cover the mouth parts of said hollowed formations (16).

25. The element according to Claim 24, in which said hollowed formations (16) receive masses (18) of superabsorbent material with characteristics of absorption of body fluid differentiated between the two opposite faces of said first layer of sheet material (10).

30

26. A sanitary article comprising an absorbent element according to any one of Claims 1 to 25.

27. A sanitary article comprising a plurality of absorbent elements according to any one of Claims 1 to 25.

28. The sanitary article according to Claim 27, in which the absorbent elements of said plurality have characteristics of absorption differentiated from one another.

29. A method for producing absorbent elements for the absorption of body fluids in sanitary articles, comprising the operations of:

- providing (100) a first layer of sheet material presenting an array of hollowed formations (16) with respective mouth parts;
- arranging (108) in said hollowed formations (16) masses (18) of superabsorbent material expandable as a result of the absorption of body fluid;
- applying a second layer of sheet material (12) covering the mouth parts of said hollowed formations (16) of said first layer of sheet material (10);
- using, for at least one of said first and second layers, a layer of sheet material (10, 12) permeable to body fluids to enable the body fluids themselves to penetrate into said hollowed formations (16) and be absorbed by said masses of superabsorbent material (18) that expand in said hollowed formations (16); said second layer of sheet material (12) being compliant in an area corresponding to the mouth parts of said hollowed formations (16), enabling the further expansion of said masses of superabsorbent material (18) beyond said hollowed formations (16).

30. The method according to Claim 29, comprising the operation of connecting to one another said first (10) and second (12) layers of sheet material with adhesive formations (14c) that leave the mouth parts of said hollowed formations (16) at least partially free.

31. The method according to Claim 30, comprising the operation of leaving the mouth parts of said hollowed formations (16) free for a fraction that ranges from 33% to 100% of the area of said mouth parts.

32. The method according to any one of Claims 29 to 31, comprising the operation of using for both of said layers of sheet material (10, 12) materials permeable to said body fluids.

33. The method according to any one of the preceding Claims 29 to 32, comprising the operation of leaving said first layer of sheet material (10) exempt from said hollowed formations (16) in an area corresponding to at least part (10a, 10b) of its border.

34. The method according to any one of the preceding Claims 29 to 33, in which said hollowed formations (16) form a continuous array in said first layer of sheet material (10).

35. The method according to any one of the preceding Claims 29 to 34, in which said hollowed formations define a uniform array.

36. The method according to any one of the preceding Claims 29 to 35, in which said hollowed formations are hexagonal in shape, so that said array has a honeycomb appearance.

5

37. The method according to any one of the preceding Claims 29 to 36, comprising the operation of using non-woven fabric for at least one, and preferentially for both of said first layer (10) and said second layer (12) of sheet material.

10

38. The method according to any one of the preceding Claims 29 to 37, comprising the operation of providing, in said second layer of sheet material (12), at least in an area corresponding to the mouth parts of said hollowed formations (16) of said first layer of sheet material, areas (12c) that are more compliant than the adjacent areas of said second layer of sheet material (12).

15

20

39. The method according to Claim 38, comprising the operation of forming said areas (12c) of greater compliance via weakening or pleating.

25

40. The element according to either Claim 38 or Claim 39, comprising the operation of forming said areas (12c) of greater compliance with capacity of extension increased by 1.5 to 3 times with respect to the adjacent areas of said second layer of sheet material (12).

30

41. The method according to any one of Claims 38 to 40, comprising the operation of leaving said second layer of sheet material (12) without said areas (12c)

of greater compliance in an area corresponding to at least part (12a, 12b) of its border.

42. The method according to Claim 30, comprising
5 the operation of creating said adhesive formations (14c) in the form of strips at least in an area corresponding to said hollowed formations (16).

43. The method according to Claim 42, comprising
10 the operation of creating said adhesive formations (14c), at least in an area corresponding to said hollowed formations (16), in the form of strips that extend in a longitudinal direction with respect to the element (C).

15 44. The method according to Claim 42 or Claim 43, comprising the operation of creating said adhesive formations (14c), at least in an area corresponding to said hollowed formations (16), in the form of strips
20 set apart from one another by gaps.

45. The method according to Claim 44, in which said gaps have a width of between 1 and 30 mm.

25 46. The method according to Claim 30, in which said adhesive formations (14c) consist of hot-melt glue.

30 47. The method according to any one of the preceding Claims 29 to 46, comprising the operation of anchoring said masses (18) of superabsorbent material in said hollowed formations (16) with a hydrosoluble adhesive (20) soluble by said body fluids.

48. The method according to any one of the preceding Claims 29 to 47, comprising the operation of connecting said first and second layers of sheet material (10, 12) with hydrosoluble adhesive formations (20a) set so as to separate hollowed formations (16) adjacent to one another; said hydrosoluble adhesive formations (20a) being soluble by said body fluids to enable said further expansion of said masses of superabsorbent material (18) beyond said hollowed formations (16).

49. The method according to Claim 30 and Claim 48, comprising the operation of connecting to one another said first layer (10) and said second layer (12) of sheet material both with stable adhesive formations (14c), which leave the mouth parts of said hollowed formations (16) at least partially free, and with said hydrosoluble adhesive formations (20a).

50. The method according to any one of the preceding Claims 29 to 49, comprising the operation of distributing said masses (18) of superabsorbent material in different amounts in different areas of the element.

51. The method according to any one of the preceding Claims 29 to 50, in which, following the absorption of body fluids, said masses of superabsorbent material (18) expand:

- for 70-90% of their overall volume of expansion, in said hollowed formations (16),
- for the remaining 30-10% of their overall volume of expansion, beyond said hollowed formations (16).

52. The method according to any one of the preceding Claims 29 to 51, comprising the operations of:

- providing a said first layer of sheet material (10) presenting arrays of hollowed formations (16) with respective mouth parts on both of its opposite faces;
- arranging in said hollowed formations (16) masses (18) of superabsorbent material that is able to expand as a result of the absorption of body fluid; and
- applying a pair of said second layers of sheet material (12) on the opposite faces of said first layer of sheet material (10) so as to cover the mouth parts of said hollowed formations (16).

53. The method according to Claim 52, comprising the operation of arranging, in said hollowed formations (16), superabsorbent material with characteristics of absorption of body fluid differentiated between the two opposite faces of said first layer of sheet material (10).

54. The method according to any one of the preceding Claims 29 to 53, in which at least the operations of providing an array of hollowed formations (16) with respective mouth parts in said first layer of sheet material (10), arranging said masses (18) of superabsorbent material in said hollowed formations (16), and applying (126) said second layer of sheet material (12) on said first layer of sheet material (10) are performed in workstations (100, 108, 126) set around a carousel structure (200) for drawing of said first layer of sheet material (10).

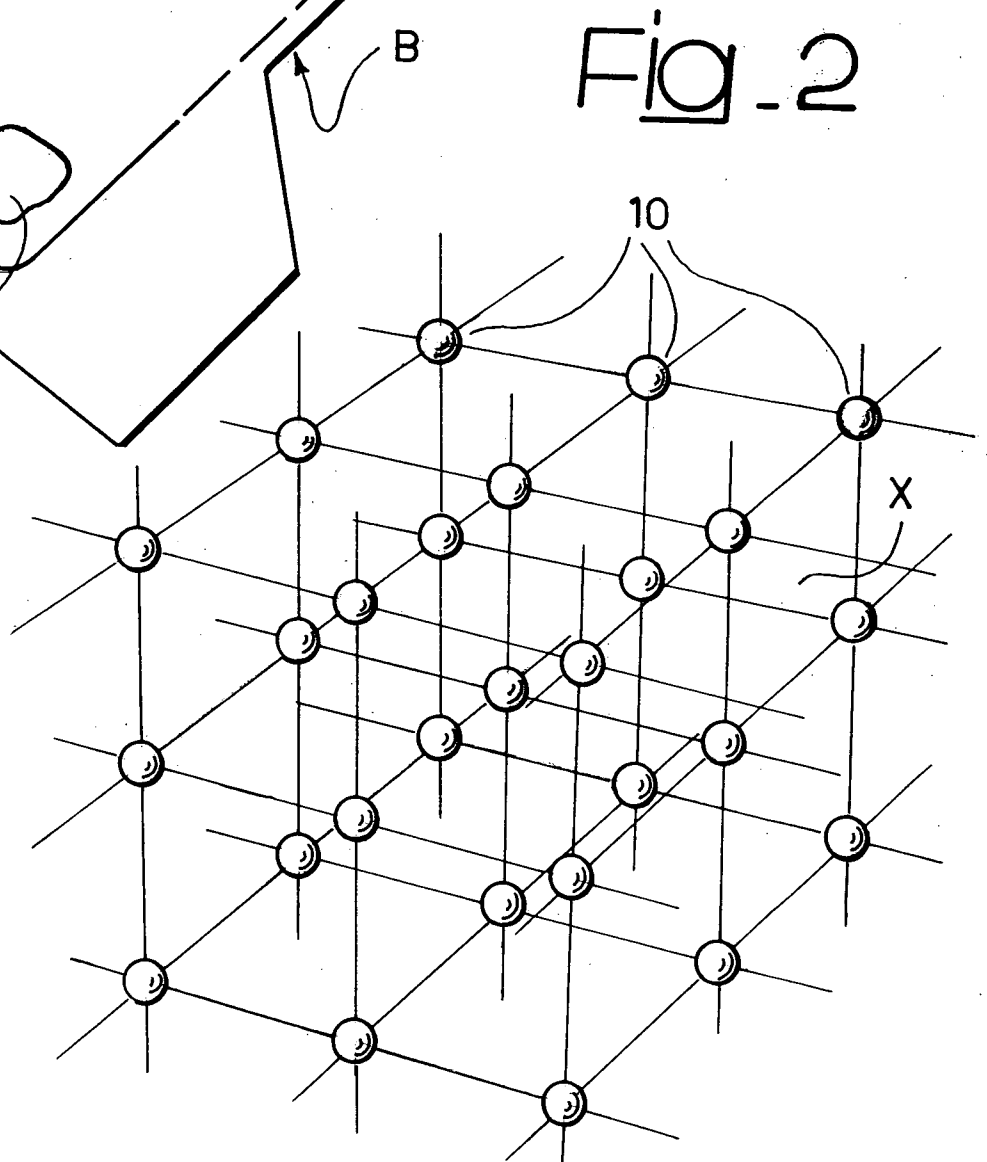
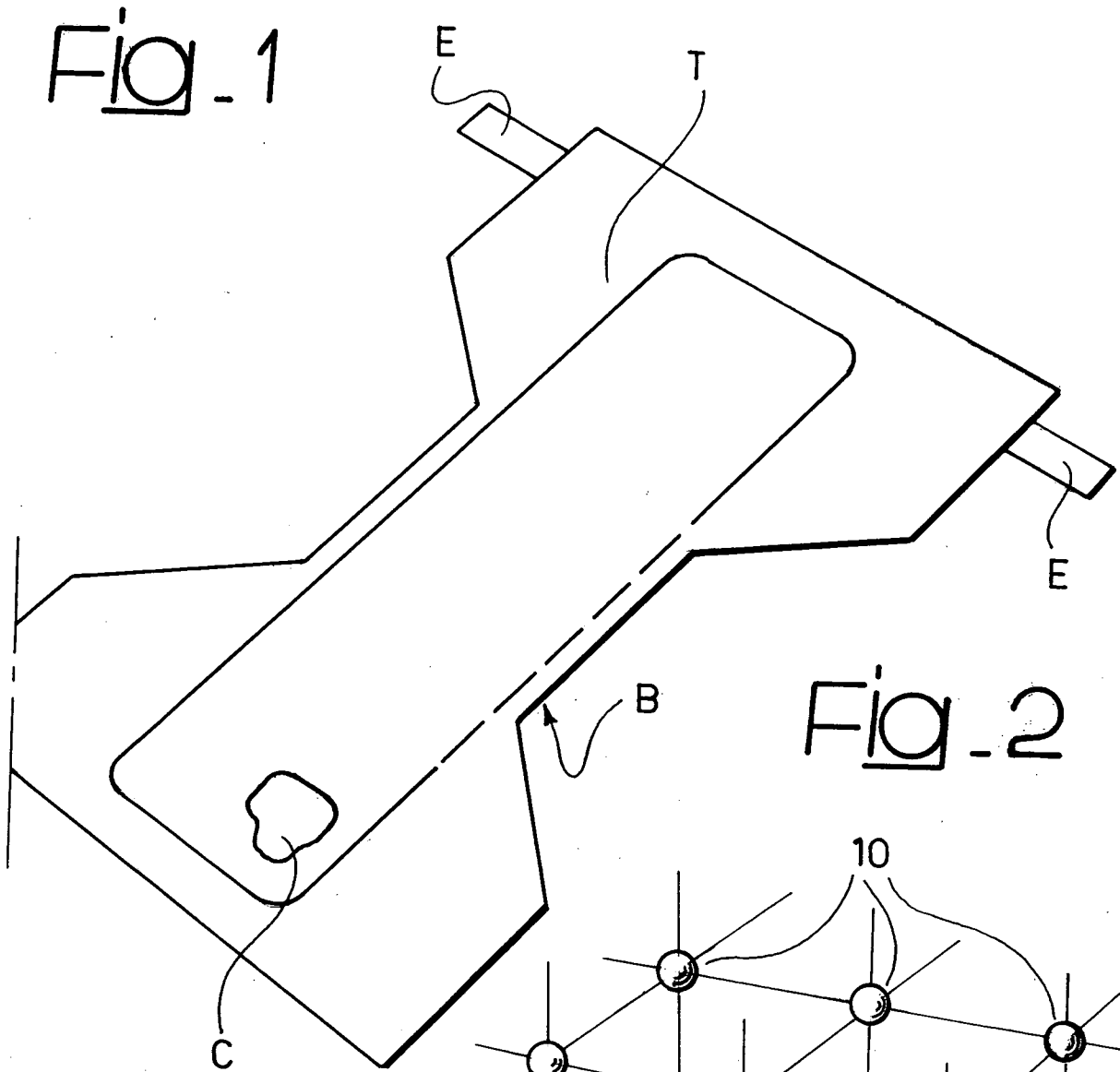

Fig. 3

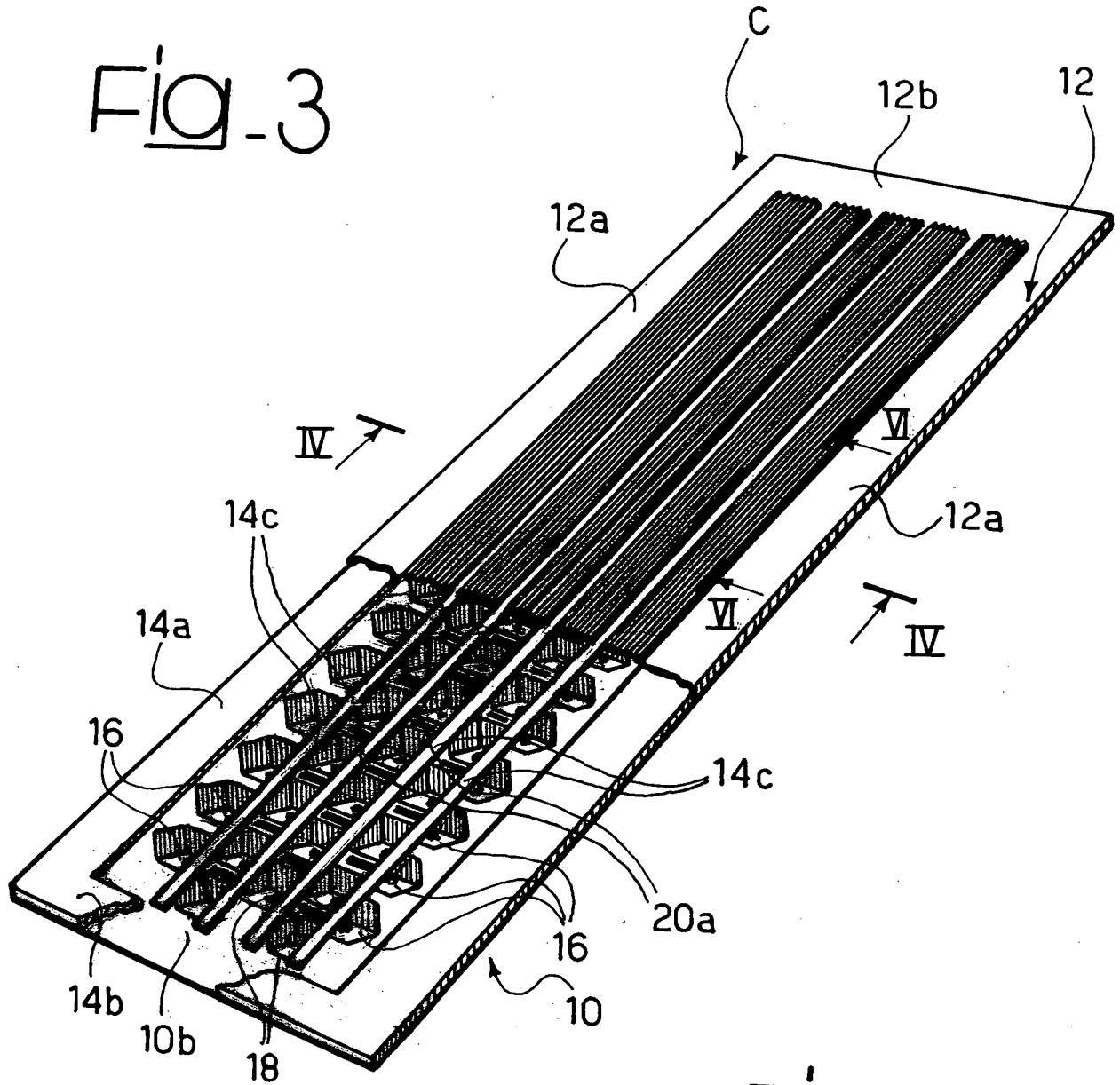

Fig. 4

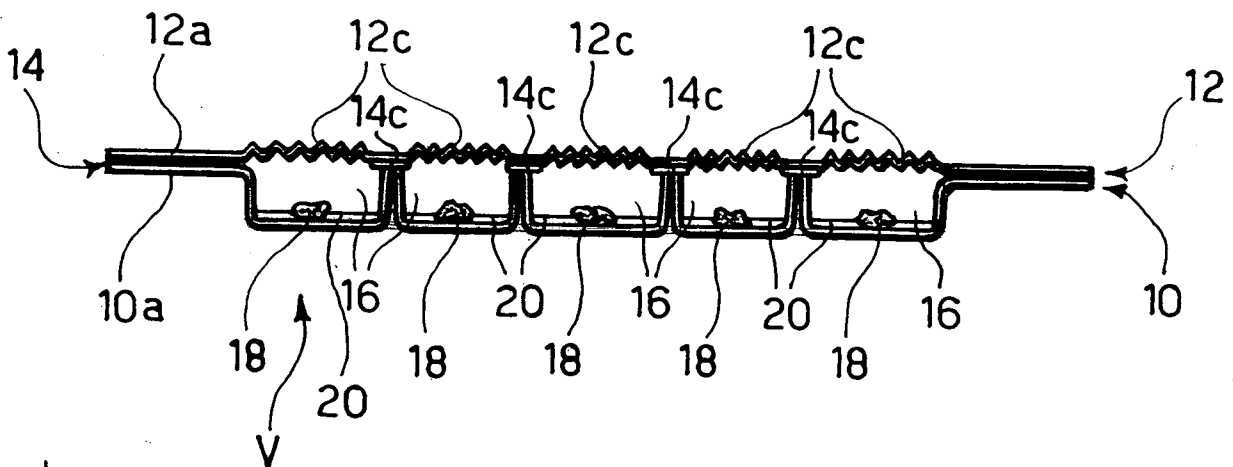

Fig. 5

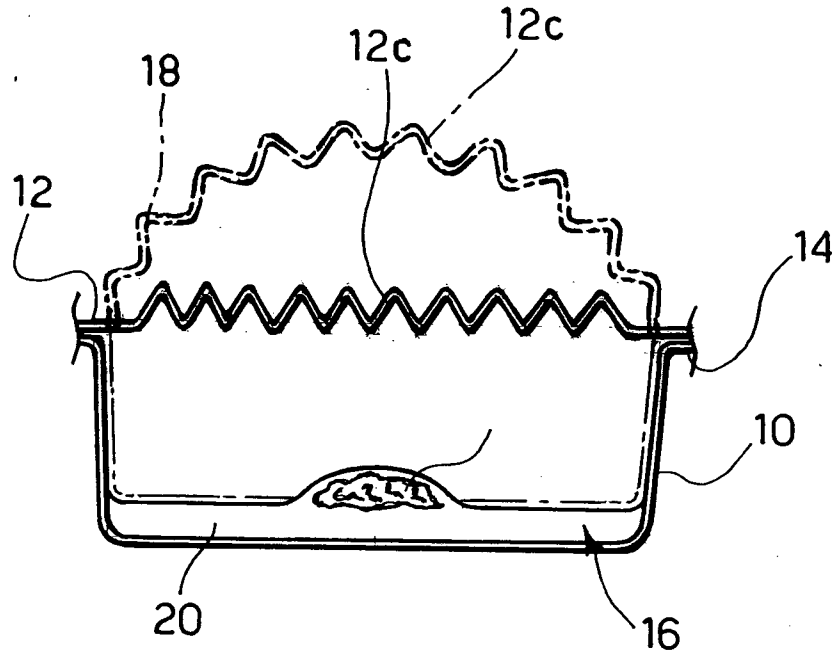

Fig. 10

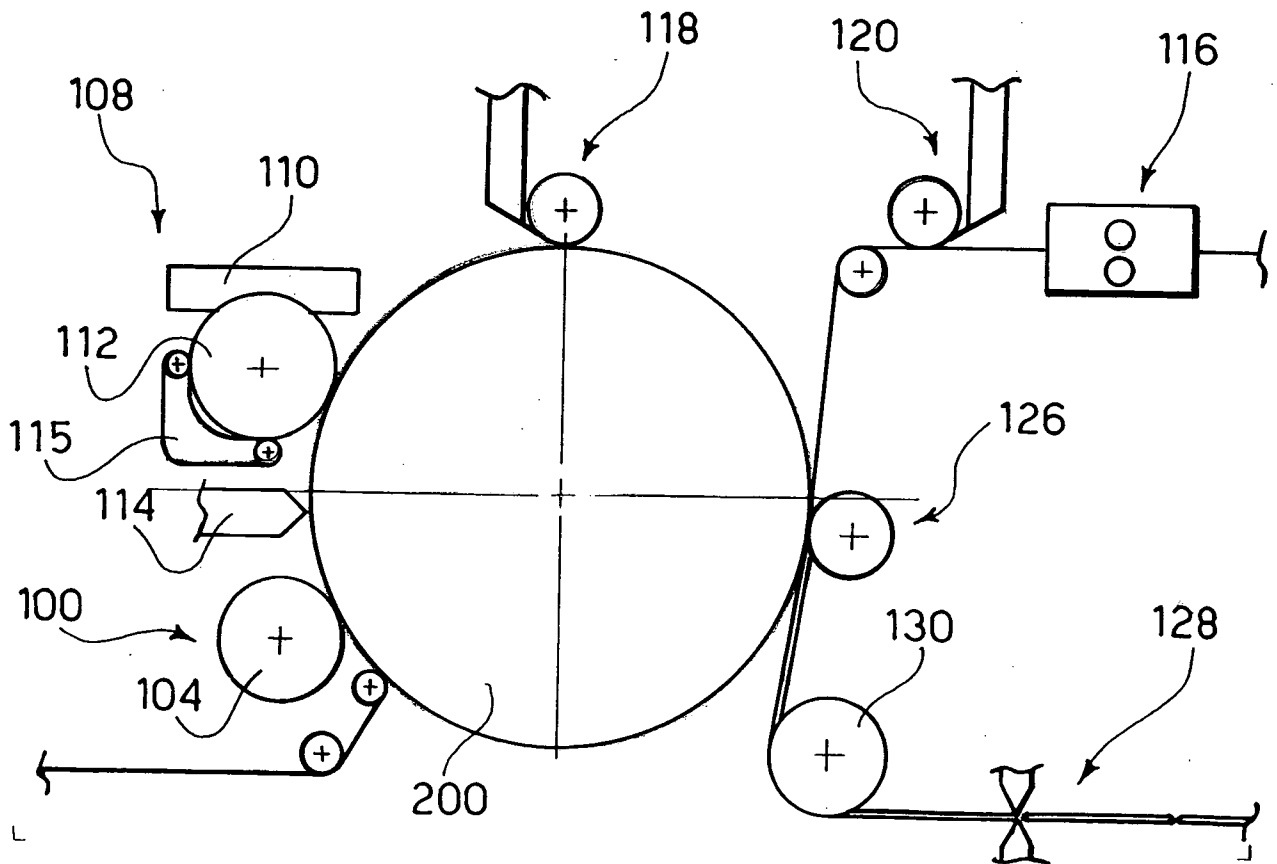

Fig. 6

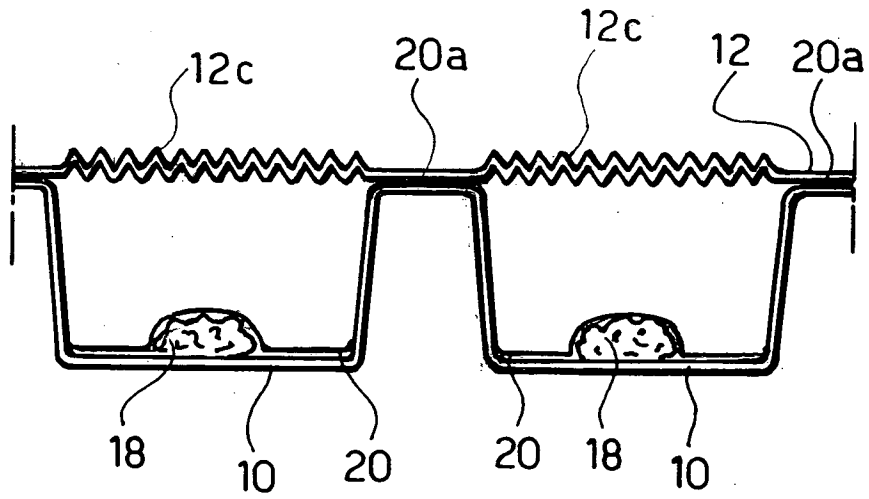

Fig. 7

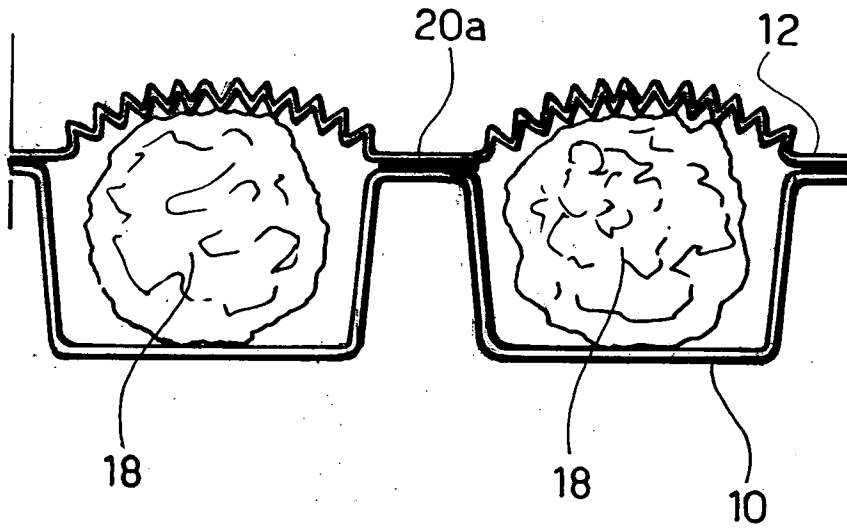

Fig. 8

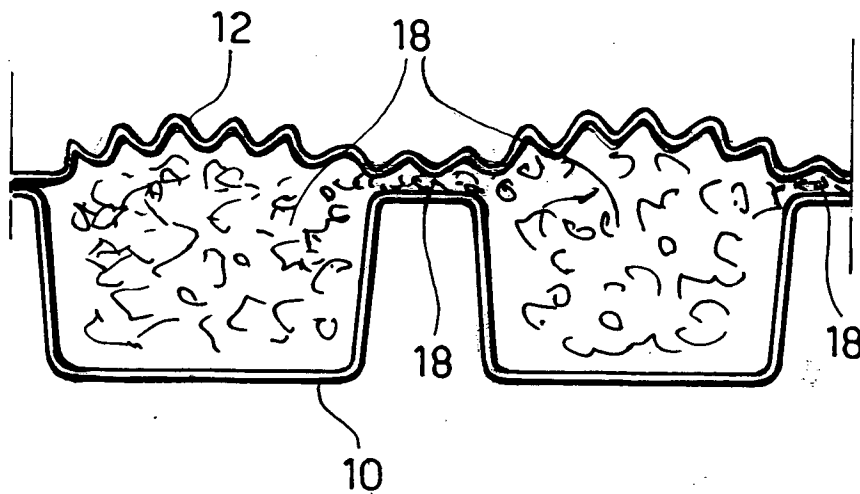
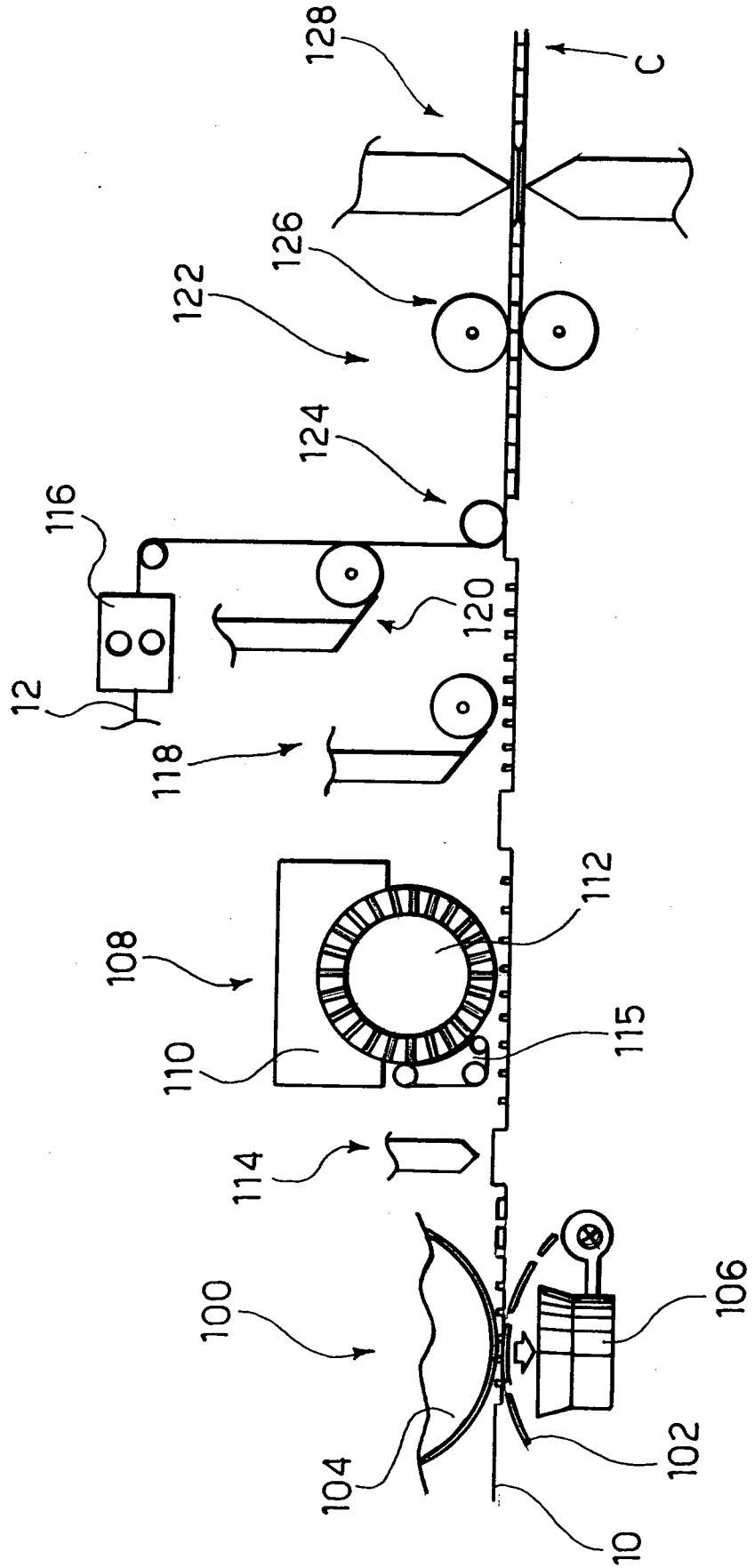

FIG. 9



INTERNATIONAL SEARCH REPORT

International application No

PCT/IB2007/003904

A. CLASSIFICATION OF SUBJECT MATTER.

INV. A61F13/532

According to International Patent Classification (IPC) or to both national classification and IPC

B. FIELDS SEARCHED

Minimum documentation searched (classification system followed by classification symbols)

A61F

Documentation searched other than minimum documentation to the extent that such documents are included in the fields searched

Electronic data base consulted during the international search (name of data base and, where practical, search terms used)

EPO-Internal

C. DOCUMENTS CONSIDERED TO BE RELEVANT

Category*	Citation of document, with indication, where appropriate, of the relevant passages	Relevant to claim No.
X	US 5 788 684 A (ABUTO FRANK PAUL [US] ET AL) 4 August 1998 (1998-08-04) column 7, line 53 - column 8, line 47; claims; figures; example 4	1-10, 13, 18, 20, 22-26, 29-37, 46, 48, 50, 52, 54
Y	US 6 129 717 A (FUJIOKA YOSHIHISA [JP] ET AL) 10 October 2000 (2000-10-10) the whole document	1-13, 18, 23, 26
Y	US 4 381 783 A (ELIAS ROBERT T) 3 May 1983 (1983-05-03) column 10, line 50 - column 11, line 16; claims; figures	1-13, 18, 23, 26
	----- -/--	

 Further documents are listed in the continuation of Box C. See patent family annex.

* Special categories of cited documents :

A document defining the general state of the art which is not considered to be of particular relevance

E earlier document but published on or after the international filing date

L document which may throw doubts on priority claim(s) or which is cited to establish the publication date of another citation or other special reason (as specified)

O document referring to an oral disclosure, use, exhibition or other means

P document published prior to the international filing date but later than the priority date claimed

T later document published after the international filing date or priority date and not in conflict with the application but cited to understand the principle or theory underlying the invention

X document of particular relevance; the claimed invention cannot be considered novel or cannot be considered to involve an inventive step when the document is taken alone

Y document of particular relevance; the claimed invention cannot be considered to involve an inventive step when the document is combined with one or more other such documents, such combination being obvious to a person skilled in the art.

& document member of the same patent family

Date of the actual completion of the international search

18 June 2008

Date of mailing of the international search report

30/06/2008

Name and mailing address of the ISA/

European Patent Office, P.B. 5818 Patentlaan 2
NL - 2280 HV Rijswijk
Tel. (+31-70) 340-2040, Tx. 31 651 epo nl,
Fax: (+31-70) 340-3016

Authorized officer

Douskas, K

INTERNATIONAL SEARCH REPORT

International application No
PCT/IB2007/003904

C(Continuation). DOCUMENTS CONSIDERED TO BE RELEVANT		
Category*	Citation of document, with indication, where appropriate, of the relevant passages	Relevant to claim No.
A	WO 97/11660 A (PARAGON TRADE BRANDS INC [US]) 3 April 1997 (1997-04-03) claims; figures	1
A	EP 0 875 224 A (CIDIEFFE S R L [IT]) 4 November 1998 (1998-11-04) claims; figures	1

INTERNATIONAL SEARCH REPORT

Information on patent family members

International application No

PCT/IB2007/003904

Patent document cited in search report	Publication date	Patent family member(s)	Publication date	
US 5788684	A	04-08-1998	AU 702387 B2	18-02-1999
			AU 3417695 A	22-03-1996
			BR 9508639 A	12-08-1997
			CA 2153125 A1	01-03-1996
			CN 1156401 A	06-08-1997
			DE 69516413 D1	25-05-2000
			DE 69516413 T2	04-01-2001
			EP 0778762 A1	18-06-1997
			ES 2144627 T3	16-06-2000
			PL 318804 A1	07-07-1997
			WO 9606590 A1	07-03-1996
			US 6129717	A
AU 2839297 A	15-01-1998			
CN 1174020 A	25-02-1998			
DE 69736940 T2	14-06-2007			
EP 0826349 A2	04-03-1998			
ID 17506 A	08-01-1998			
JP 3499375 B2	23-02-2004			
JP 10014978 A	20-01-1998			
SG 73461 A1	20-06-2000			
US 4381783	A	03-05-1983		
WO 9711660	A	03-04-1997	US 5863288 A	26-01-1999
EP 0875224	A	04-11-1998	NONE	