

Jan. 22, 1929.

1,700,044

S. E. HALES

PNEUMATIC AND HYDRAULIC APPARATUS

Filed May 7, 1927

2 Sheets-Sheet 2

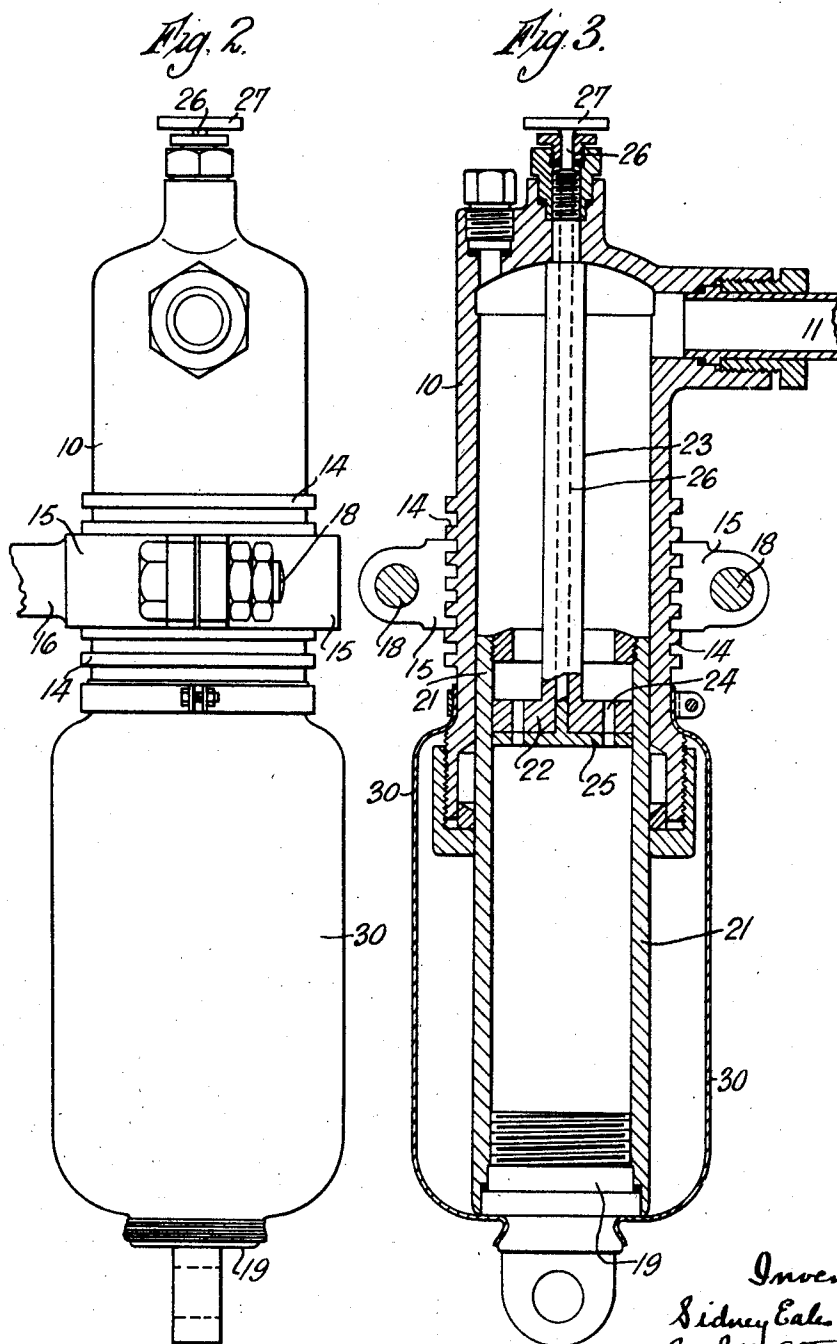

Inventor:
Sidney E. Hales
By his Attorneys,
Pullover & Wright

UNITED STATES PATENT OFFICE.

SIDNEY EALES HALES, OF KINGSTON-ON-THAMES, ENGLAND.

PNEUMATIC AND HYDRAULIC APPARATUS.

Application filed May 7, 1927, Serial No. 189,678, and in Great Britain May 10, 1926.

This invention relates to pneumatic and hydraulic apparatus suitable for use as a spring, shock absorber, jack or the like, and of the type comprising a flexible pneumatic element located in a chamber containing liquid which is subjected to variations in pressure.

According to the present invention, apparatus of the type described, comprises in combination a chamber in which the pneumatic element is located, a cylinder in communication with said chamber, and a ram in said cylinder.

A plurality of cylinders may, if desired, be connected to a single pneumatic element.

Preferably means are provided for checking or regulating the rate of flow of the liquid, whereby the rate of movement of the ram, relatively to the cylinder, is controlled or checked.

In one form of construction the apparatus comprises a cylinder, the inner end of which is in communication with a cylindrical casing containing a flexible pneumatic tube. The ends of the casing are closed by plates which are drawn together in such a manner that the ends of the tube are nipped between the plates and casing, thus forming an airtight joint.

The ends of the casing and the plates, near to their periphery, are preferably bevelled at say, an angle of 45° , in order that an airtight joint may readily be formed. The plates are drawn together by means of a bolt which may conveniently be provided with a central passage leading at one end into the interior of the tube, and at the other end to a valve, such as is used in connection with pneumatic tyres, thus affording a ready means for permitting air to be introduced into the tube.

In order to regulate the rate at which movement of the ram can take place relatively to the cylinder, I may provide a control member, such as a needle valve or a "hit and miss" valve, by means of which the flow of liquid can be regulated or checked.

In operation, if the apparatus be employed as a spring or shock absorber, the tube is inflated to the requisite degree, depending upon the load, while if the apparatus be employed as a jack, the relative movement between the ram and cylinder is effected by pumping air into the tube, or allowing it to escape therefrom.

The invention is illustrated in the accompanying drawings, as applied to the suspen-

sion of an automobile. In these drawings, Figure 1 is an elevation, Figure 2 a detail end elevation, Figure 3 a vertical section of Figure 2, and Figure 4 a detail horizontal section.

1 is a cylindrical casing, the ends of which are bevelled at an angle, and 2 is a flexible tube which is clamped on the bevelled ends of the casing 1 by end plates 3 which are similarly bevelled and are drawn on to the ends of the casing 1 by bolts 4 passing through holes in the end plates 3 and casing. A central bolt 5 is provided with a central passage 6 leading at one end into the interior of the tube 2 and at the other end to a valve 7 such as is used for the inflation of pneumatic tyres. The chamber 8, formed between the casing 1 and tube 2, is provided with a port 9 which is placed in communication with the upper end of a cylinder 10 through a flexible pipe 11, and 12 is a second port which is placed in communication with a second cylinder (not shown) similar to the cylinder 10, by a flexible pipe 13. The cylinder 10 is provided with projections 14 which engage a correspondingly grooved split block 15, provided with a trunnion 16 pivotally mounted in a bracket secured to, or carried by, the chassis 17 of an automobile, and is provided with bolts 18 for clamping the cylinder 10 in position.

19 is a ram which is pivotally connected to the front axle 20 of the automobile and is carried by a tube 21, slidably mounted in the cylinder 10. Located within the tube 21 is a control member 22 which is secured by means of a rod 23 to the cylinder 10, and is provided with slots 24 which can more or less be uncovered by a slotted disk 25 fast with a rod 26 provided at its upper end with an operating knob 27. 28 is a radius rod pivotally connected to the axle 20 and to a block 29 secured to the chassis.

30 is a flexible dust cover secured to the ram 19 and the cylinder 10.

31 is a pipe by means of which the chamber 8 can be placed in communication with a pressure gauge.

In operation the cylinder 10, the tube 21, the flexible pipes 11, 13, and the chamber 8 are filled with oil, and the flexible tube 2 is inflated to the requisite degree, depending upon the load to be carried by the automobile. When the ram 19 is slidden inwardly, relatively to the cylinder 10, oil is caused to flow from the cylinder 10 to the chamber 8,

whereby the air within the tube 2 is compressed and the movement of the ram 19 resiliently damped. The rate of flow of oil through the slots 24, and hence the rate of movement of the ram, can be varied by more or less uncovering the slots 24 by the slotted disk 25.

It is obvious that a plurality of flexible tubes 2 and castings 1 may be employed with which the cylinder or cylinders can be placed in communication and that with such an arrangement the amount of movement imparted to the ram or rams 19 by a given shock can be regulated by altering the number of tubes and casings which are placed in communication with the said cylinder or cylinders. This can be effected in any convenient manner as for example by means of control cocks which can be located in any convenient position on the vehicle.

I claim:—

1. In pneumatic and hydraulic apparatus the combination of a chamber containing liquid, a flexible pneumatic element located in said chamber, a cylinder in communication with said chamber, a ram in said cylinder, and means for regulating the rate of flow of the liquid between the cylinder and the chamber.

2. In pneumatic and hydraulic apparatus the combination of a chamber containing liquid, a flexible pneumatic element located in said chamber, a cylinder in communication with said chamber, a ram in said cylinder, and a hit and miss valve for regulating the rate of flow of the liquid between the cylinder and the chamber.

3. In pneumatic and hydraulic apparatus the combination of a tubular cylinder forming a chamber adapted to contain liquid, end plates for said cylinder, a flexible tube adapted to contain air, means for clamping said flexible tube between the ends of said cylinder and said end plates, a cylinder in communication with said cylinder, and a ram in said cylinder.

4. In pneumatic and hydraulic apparatus the combination of a tubular cylinder forming a chamber adapted to receive liquid, end plates for said cylinder, a flexible tube adapted to contain air, means for clamping said flexible tube between the ends of said cylinder and said end plates, a cylinder in communication with said cylinder, a ram in said

cylinder, and means for regulating the rate of flow of the liquid between the cylinder and the chamber.

5. In pneumatic and hydraulic apparatus the combination of a tubular cylinder forming a chamber adapted to contain liquid, end plates for said cylinder, a flexible tube adapted to contain air, means for clamping said flexible tube between the ends of said cylinder and said end plates, a cylinder in communication with said cylinder, a ram in said cylinder, and a hit and miss valve for regulating the rate of flow of the liquid between the cylinder and the chamber.

6. In pneumatic and hydraulic apparatus the combination of a tubular cylinder forming a chamber adapted to receive liquid, end plates for said cylinder, a flexible tube adapted to contain air, means for clamping said flexible tube between the ends of said cylinder and said end plates, a cylinder in communication with said cylinder, a ram in said cylinder, and means for connecting the cylinder and ram to the chassis and axle of a vehicle.

7. In pneumatic and hydraulic apparatus the combination of a tubular cylinder forming a chamber adapted to receive liquid, end plates for said cylinder, a flexible tube adapted to contain air, means for clamping said flexible tube between the ends of said cylinder and said end plates, a cylinder in communication with said cylinder, a ram in said cylinder and means for connecting the cylinder and ram to the chassis and axle of a vehicle.

8. In pneumatic and hydraulic apparatus the combination of a tubular cylinder forming a chamber adapted to receive liquid, end plates for said cylinder, a flexible tube adapted to contain air, means for clamping said flexible tube between the ends of said cylinder and said end plates, a cylinder in communication with said cylinder, a ram in said cylinder, means for regulating the rate of flow of the liquid between the cylinder and the chamber and means for connecting the cylinder and ram to the chassis and axle of a vehicle.

In testimony that I claim the foregoing as my invention, I have signed my name this 28th day of April, 1927.

SIDNEY EALES HALES.