



US00D487192S

(12) **United States Design Patent** (10) **Patent No.:** **US D487,192 S**  
**Farnham et al.** (45) **Date of Patent:** **\*\* Mar. 2, 2004**

(54) **STORAGE UNIT**

D449,165 S \* 10/2001 van der Hulst ..... D3/294  
D463,276 S \* 9/2002 Piscopo et al. .... D9/420

(75) Inventors: **Mark P. Farnham**, Port Jefferson, NY  
(US); **Clive Warwicker**, Worcestershire  
(GB)

\* cited by examiner

*Primary Examiner*—Philip S. Hyder

(74) *Attorney, Agent, or Firm*—Pillsbury Winthrop LLP

(73) Assignee: **Helix Group PLC**, Stourbridge (GB)

(57) **CLAIM**

(\*\*) Term: **14 Years**

The ornamental design for a storage unit, as shown and described.

(21) Appl. No.: **29/166,445**

(22) Filed: **Aug. 28, 2002**

**DESCRIPTION**

(51) **LOC (7) Cl.** ..... **03-01**

(52) **U.S. Cl.** ..... **D3/294**

(58) **Field of Search** ..... D3/272, 273, 294,  
D3/302, 281; D9/423, 424, 425; D99/28;  
206/349, 508, 518; 220/324, 810, 837,  
796; 70/63, 66, 69, 67

FIG. 1 is a top plan view of a storage unit according to the present invention with selected structure indicated in dotted lines;

FIG. 2 is a bottom plan view thereof with selected structure indicated in dotted lines;

FIG. 3 is a right side elevational view thereof with selected structure indicated in dotted lines;

FIG. 4 is left side elevational view thereof with selected structure indicated in dotted lines;

FIG. 5 is a front elevational view thereof with selected structure indicated in dotted lines;

FIG. 6 is a rear elevational view thereof with selected structure indicated in dotted lines;

FIG. 7 is a perspective view of the storage unit illustrated in FIG. 1, shown in a closed position with selected structure indicated in dotted lines;

FIG. 8 is a perspective view, from the rear and right side, of the storage unit illustrated in FIG. 1, shown in a closed position with selected structure indicated in dotted lines;

FIG. 9 is a perspective view, from the front and left side, of the storage unit illustrated in FIG. 1, shown in an open position with selected structure indicated in dotted lines; and,

FIG. 10 is a perspective view, from the rear and right side, of the storage unit illustrated in FIG. 1, shown in an open position with selected structure indicated in dotted lines.

The dotted line showings of the storage unit or parts thereof, such as the hinge, the lock assembly and the cable, are for illustrative purposes only and form no part of the claimed design.

(56) **References Cited**

**U.S. PATENT DOCUMENTS**

2,687,157	A	*	8/1954	Cowan	.....	220/4,23
4,066,195	A		1/1978	Dickler		
D273,908	S	*	5/1984	Hoogeveen	.....	D99/28
4,474,116	A		10/1984	Castenada, Jr. et al.	.....	109/51
4,573,332	A		3/1986	Ma	.....	70/30
D284,831	S		7/1986	Warwicker	.....	D8/306
4,611,711	A		9/1986	Warwicker	.....	206/0,81
D291,139	S		7/1987	Warwicker	.....	D99/28
D296,949	S		7/1988	Warwicker	.....	D99/34
D297,195	S	*	8/1988	Warwicker	.....	D6/559
4,843,848	A		7/1989	Igelmund	.....	70/58
5,150,834	A		9/1992	Bourke		
D350,002	S	*	8/1994	Viola	.....	D99/28
D363,669	S	*	10/1995	Pennoyer, Jr.	.....	D9/423
D364,563	S	*	11/1995	Miller et al.	.....	D9/423
5,517,835	A		5/1996	Smith		
D371,906	S		7/1996	Peters	.....	D3/281
5,531,082	A		7/1996	Wolk et al.	.....	70/63
5,595,073	A		1/1997	Sullivan	.....	70/14
D393,526	S	*	4/1998	Robey et al.	.....	D99/28
5,762,169	A		6/1998	Deliman et al.	.....	109/101
D406,057	S	*	2/1999	Hager	.....	D9/420
6,006,558	A		12/1999	Peters	.....	70/63
6,185,964	B1	*	2/2001	Addiego	.....	70/58

**1 Claim, 6 Drawing Sheets**



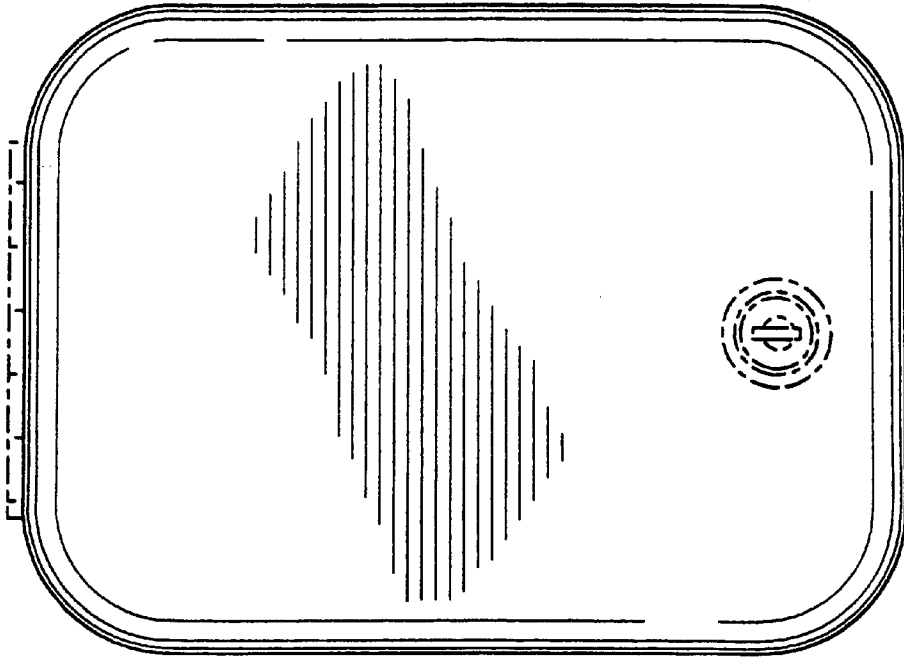

FIG. 1

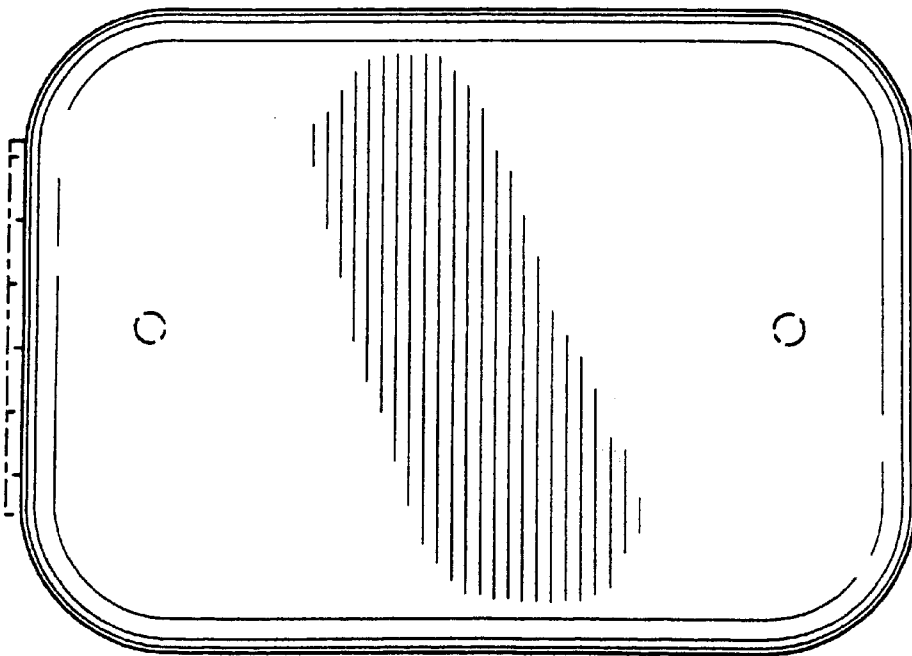

FIG. 2

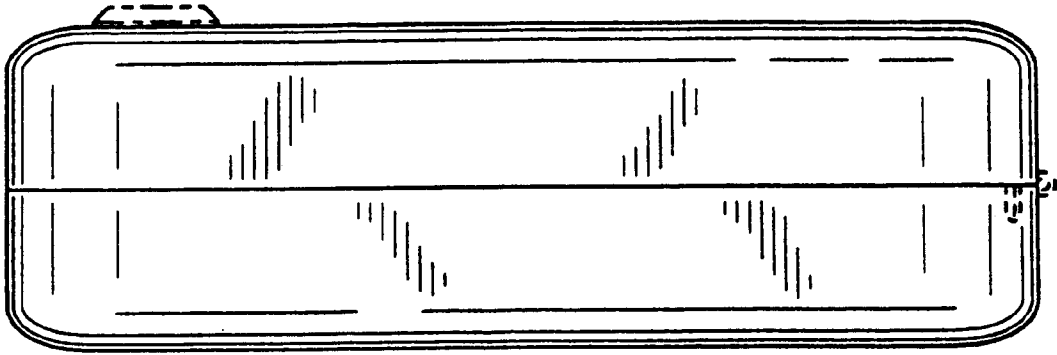

FIG. 3

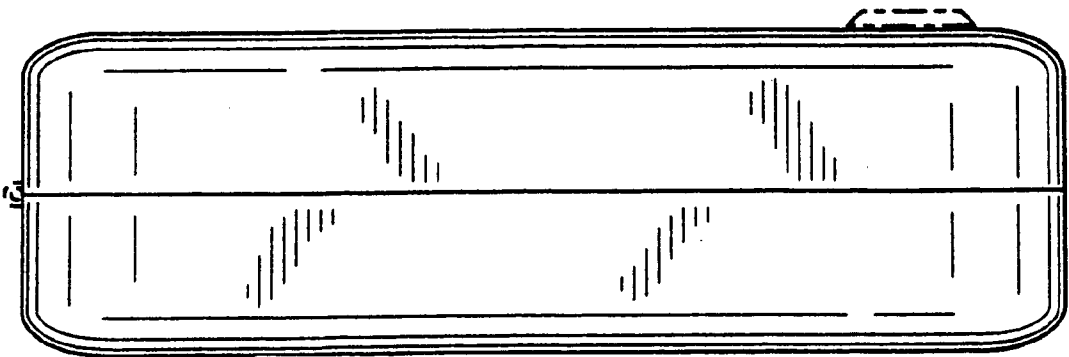

FIG. 4

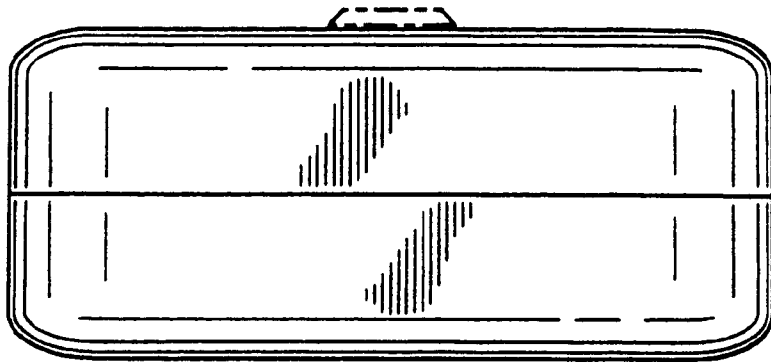

FIG. 5

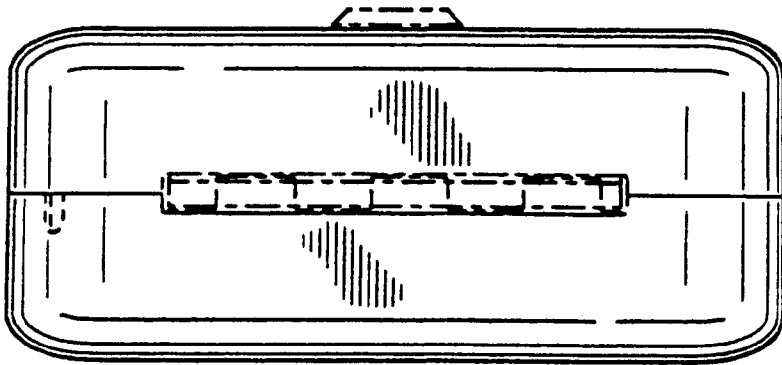

FIG. 6

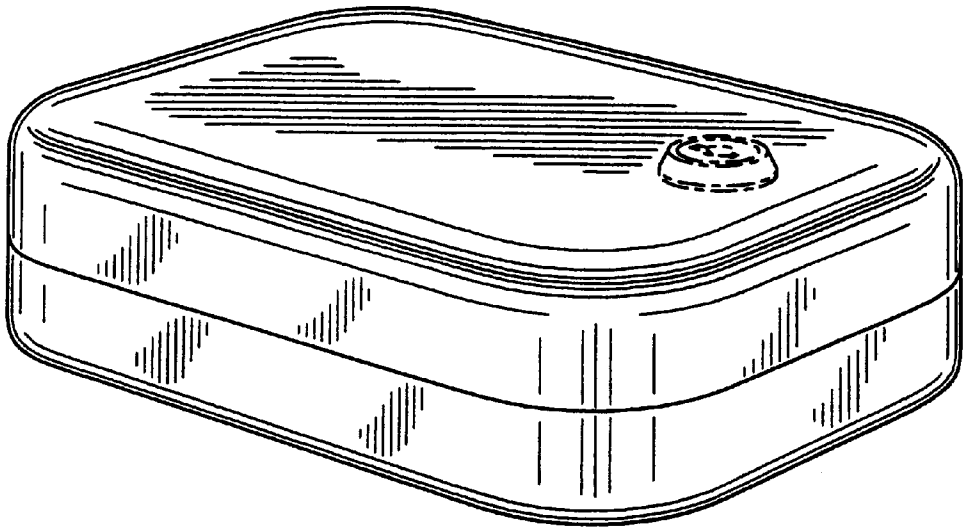

FIG. 7

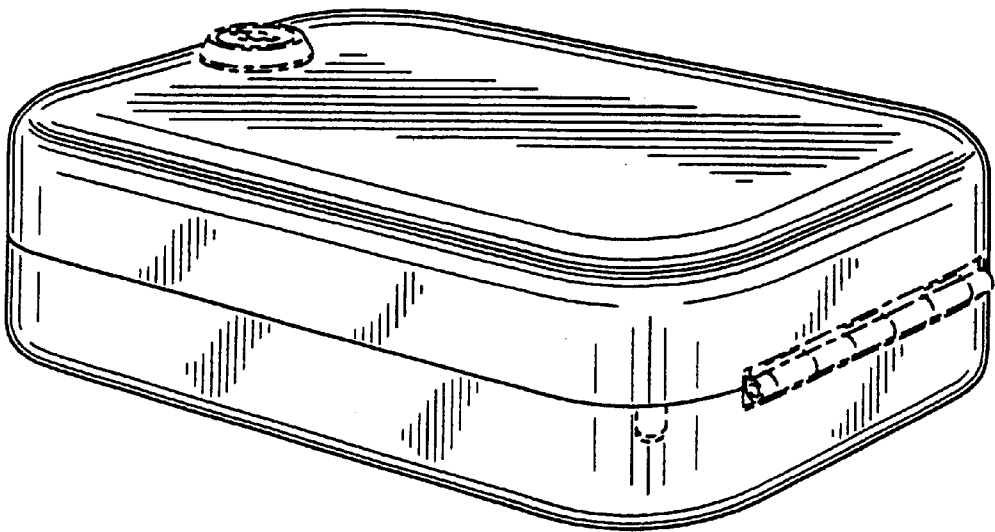

FIG. 8

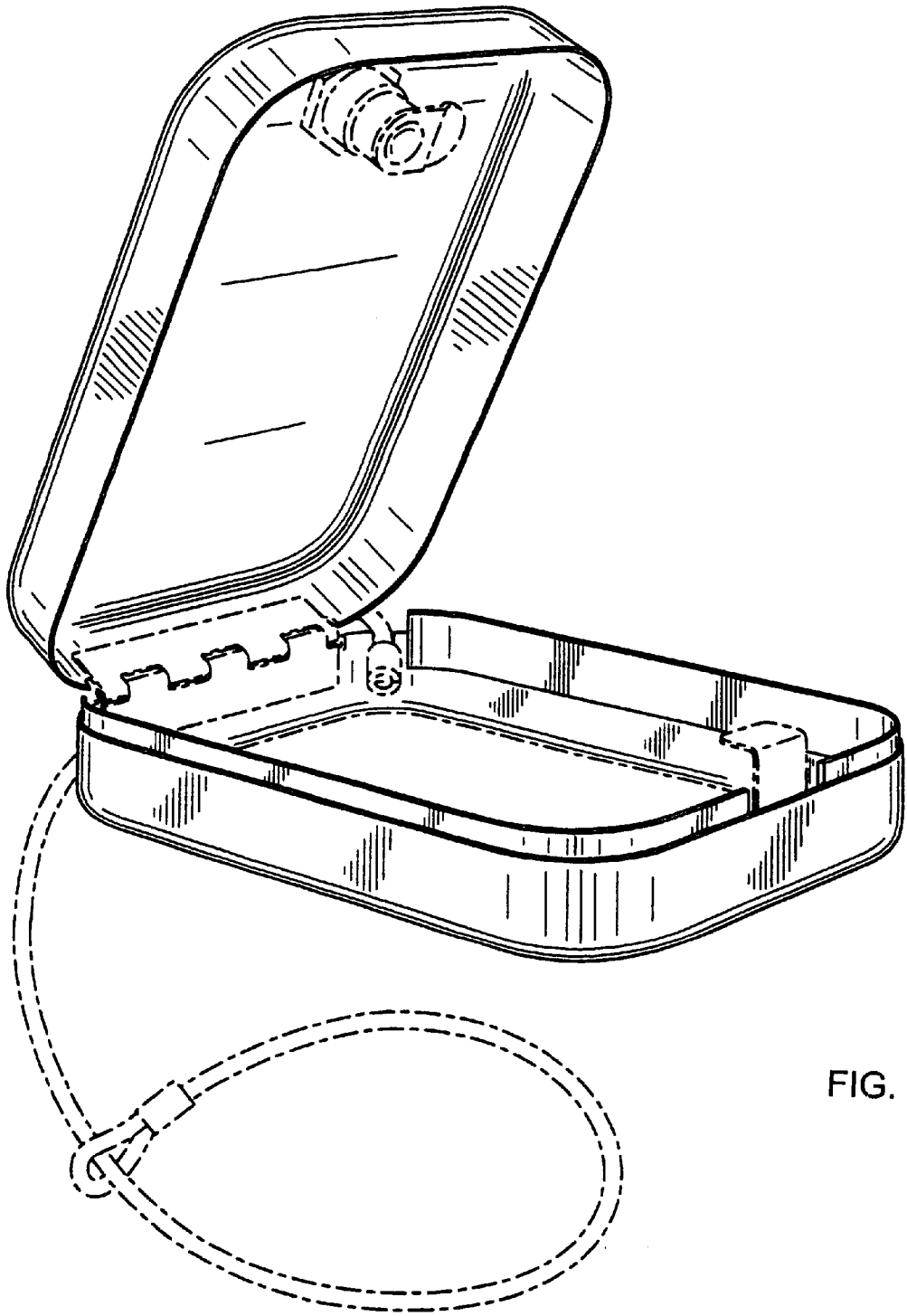

FIG. 9

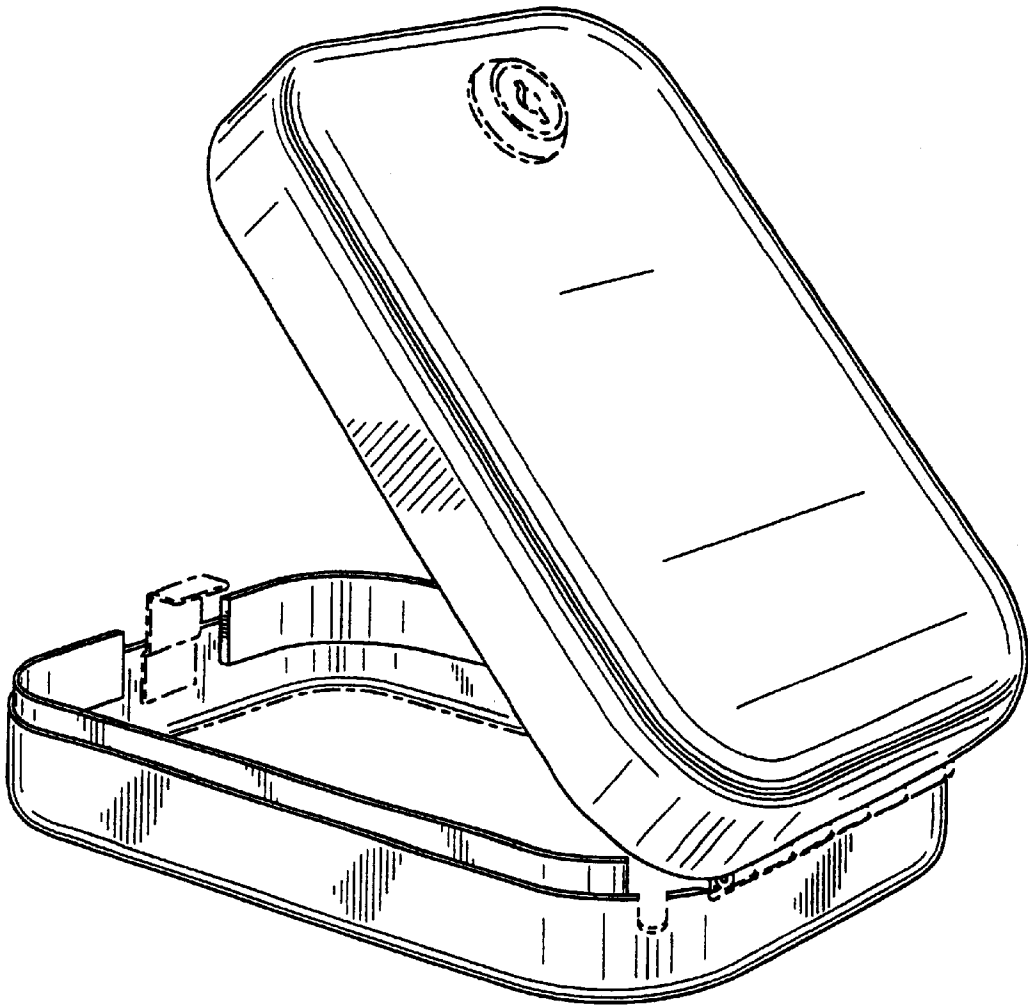

FIG. 10