

May 7, 1935.

H. FANKBONER

2,000,439

WEB RENEWING MECHANISM

Filed Oct. 15, 1931

5 Sheets-Sheet 1

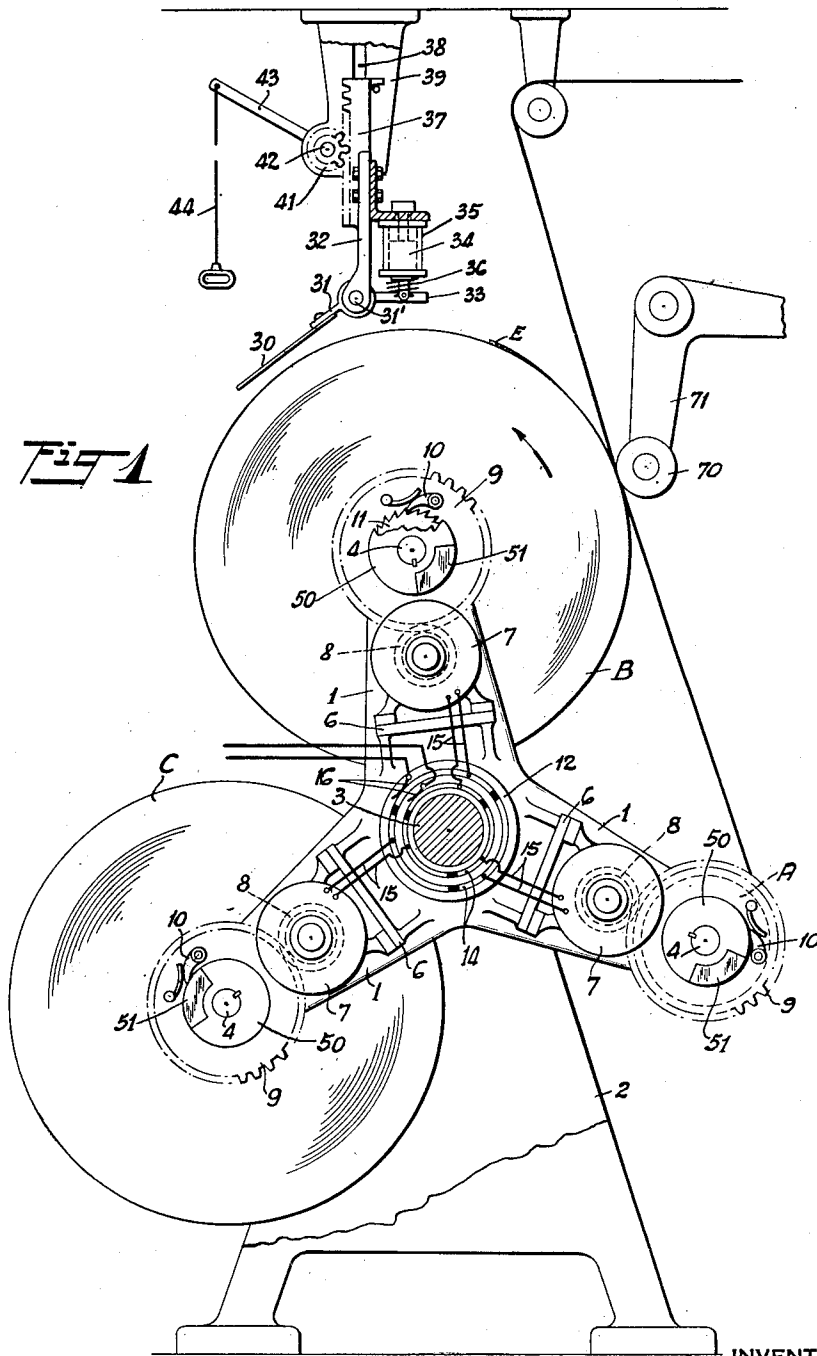

INVENTOR  
*H. Fankboner*  
BY  
*John Morgan*  
ATTORNEY

May 7, 1935.

H. FANKBONER  
WEB RENEWING MECHANISM

2,000,439

Filed Oct. 15, 1931

5 Sheets-Sheet 2

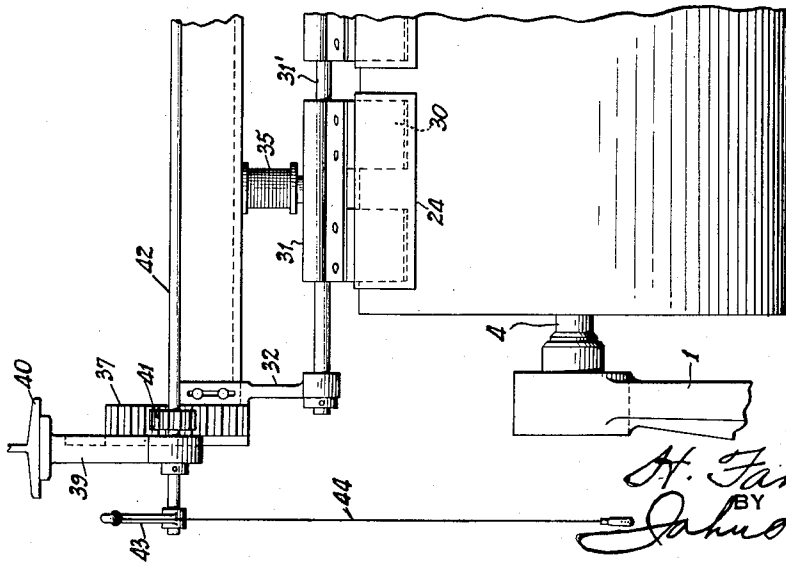
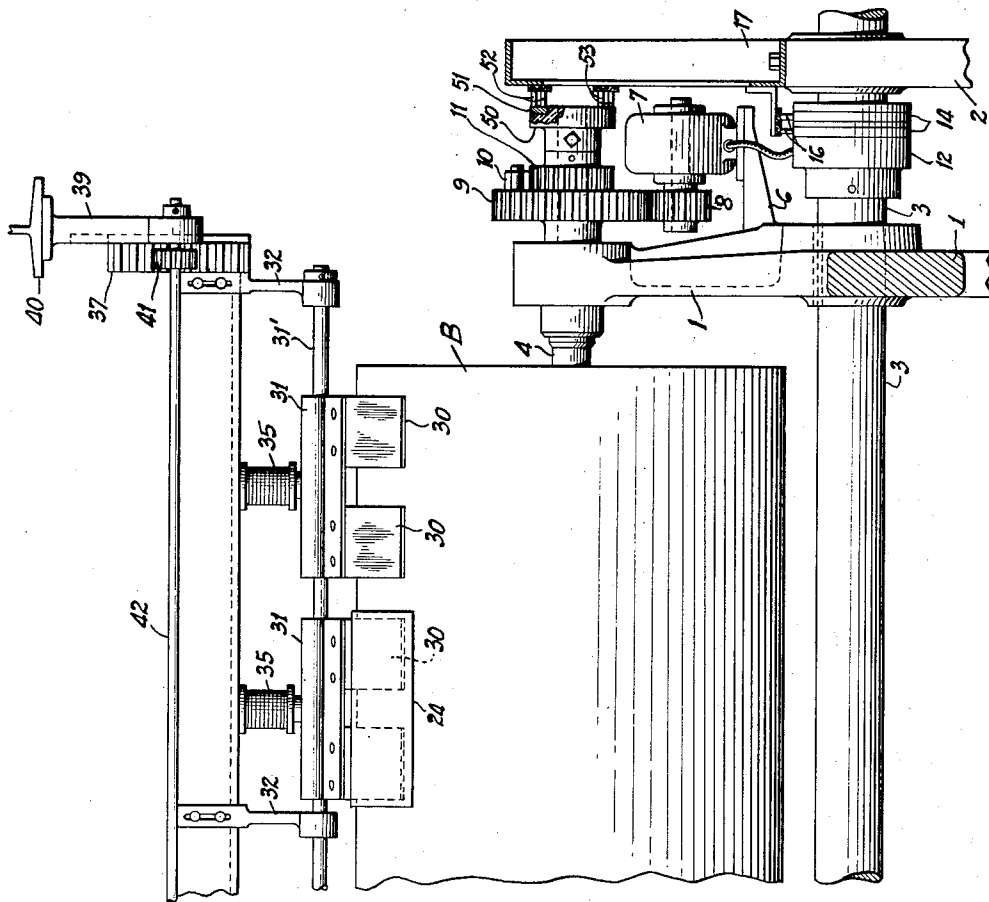

FIG. 2

INVENTOR  
*H. Fankboner*  
BY *Jahud Morgan*  
ATTORNEY



May 7, 1935.

H. FANKBONER

2,000,439

WEB RENEWING MECHANISM

Filed Oct. 15, 1931

5 Sheets-Sheet 4

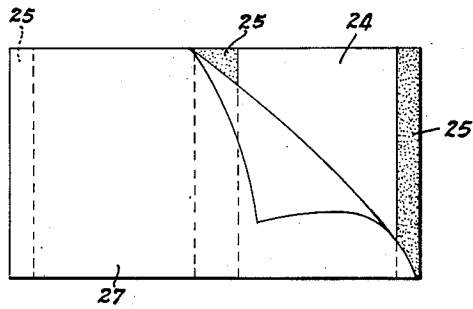

FIG 7

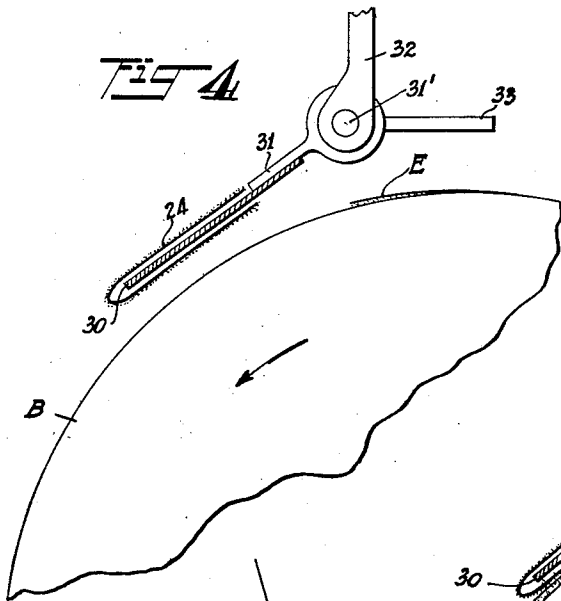

FIG 4

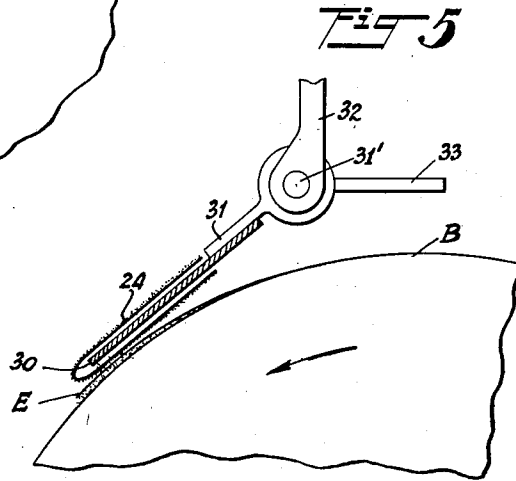

FIG 5

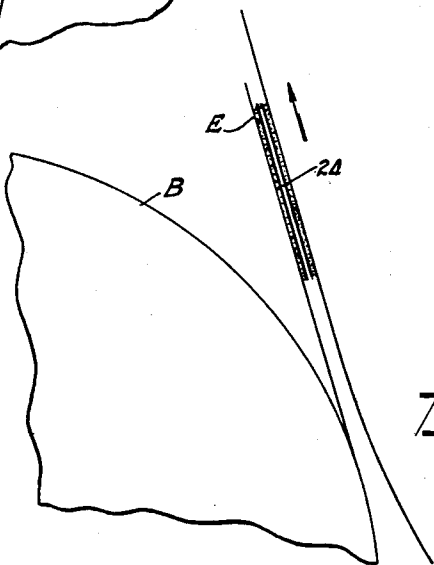

FIG 6

H. Fankboner INVENTOR  
John D. Morgan ATTORNEY

May 7, 1935.

H. FANKBONER

2,000,439

WEB RENEWING MECHANISM

Filed Oct. 15, 1931

5 Sheets-Sheet 5

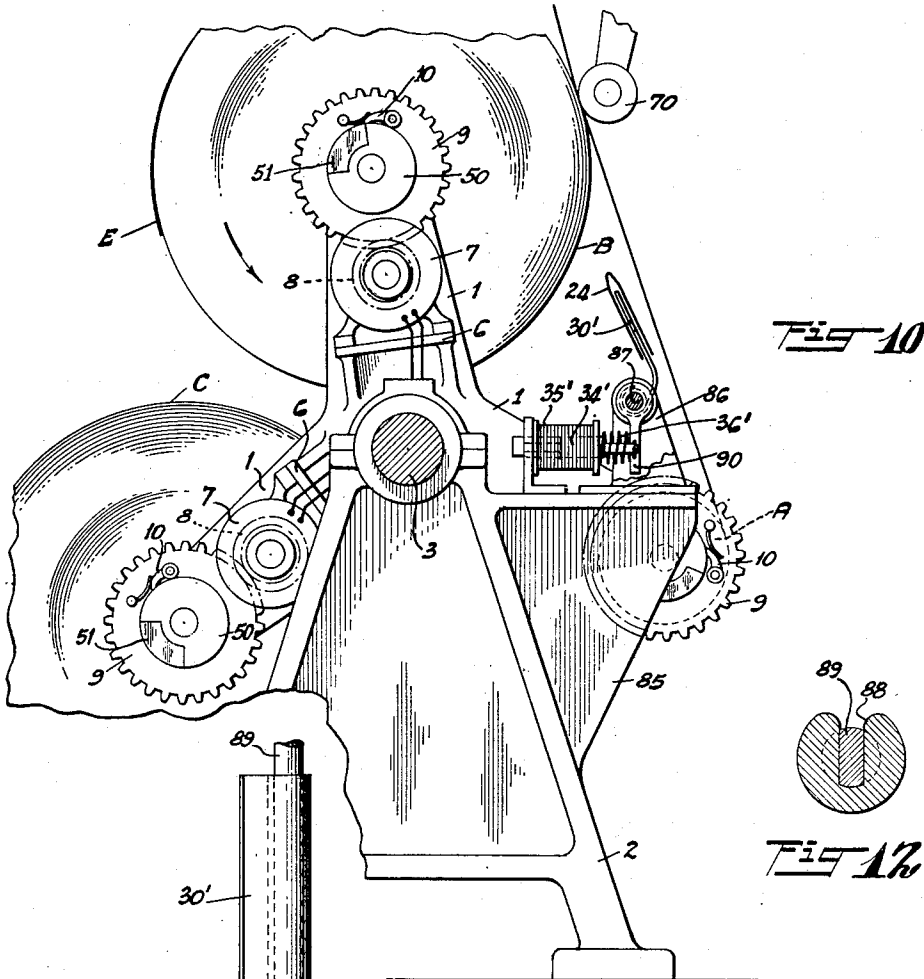

Fig 10

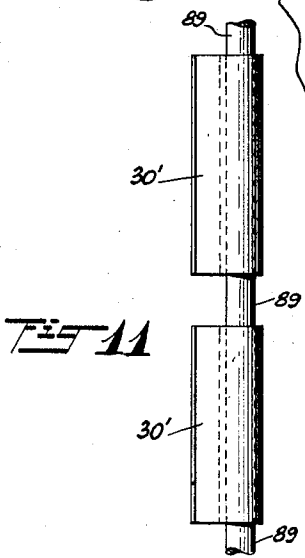

Fig 11

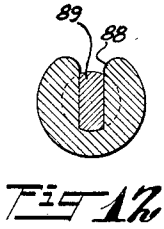

Fig 12

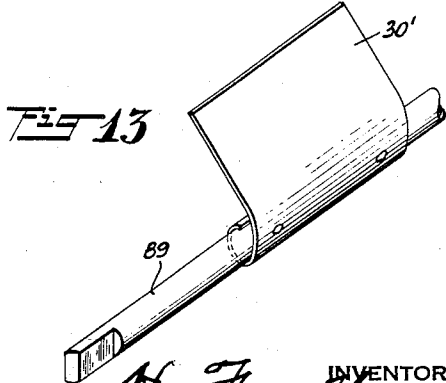
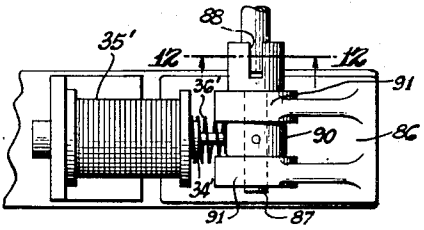

Fig 13



H. Fankboner  
BY John D. Morgan  
ATTORNEY

# UNITED STATES PATENT OFFICE

2,000,439

## WEB RENEWING MECHANISM

Harland Fankboner, Chicago, Ill., assignor to The Goss Printing Press Company, Chicago, Ill., a corporation of Illinois

Application October 15, 1931, Serial No. 569,002

22 Claims. (Cl. 242—58)

The present invention relates to web-renewing mechanism and more particularly to a novel and improved mechanism for making a flying paster for use in connection with high speed rotary printing presses.

Objects and advantages of the invention will be set forth in part hereinafter and in part will be obvious herefrom, or may be learned by practice with the invention, the same being realized and attained by means of the instrumentalities and combinations pointed out in the appended claims.

The invention consists in the novel parts, constructions, arrangements, combinations and improvements herein shown and described.

The accompanying drawings, referred to herein and constituting a part hereof, illustrate two embodiments of the invention, and together with the description, serve to explain the principles of the invention.

Of the drawings:—

Figure 1 is a side elevation of the present preferred and illustrative embodiment of the invention, with certain of the parts being broken away, and others being shown diagrammatically;

Figure 2 is a fragmentary side view of the mechanism shown in Figure 1;

Figure 3 is a circuit diagram illustrating the electrical connections between various parts of the mechanism;

Figures 4, 5 and 6 are detailed fragmentary and diagrammatic views illustrating successive phases in the operation of the web-renewing mechanism of the present invention;

Figure 7 is a detailed side elevation of one of the instrumentalities used in connection with the foregoing mechanism;

Figure 8 is a fragmentary side elevation illustrating a modified embodiment of the invention;

Figure 9 is a vertical section taken on the line 9—9 of Figure 8;

Figure 10 is a fragmentary side elevation illustrating a further modification of the invention;

Figure 11 is a fragmentary detailed plan view of the glue-applying means used in connection with the mechanism illustrated in Figure 10;

Figure 12 is a vertical section taken on the line 12—12 of Figure 11; and

Figure 13 is a perspective view of a portion of the mechanism illustrated in Figure 11.

The present invention has for its object the provision of a web-renewing apparatus and method in which the web-joining adhesive is applied to the reserve web roll after it has been contacted with the running web. A further object

is the provision of a web-renewing apparatus and method in which the leading end of the reserve web is joined to the running web by means of an adhesive member or sheet. Still another object is the provision of a web-renewing apparatus in which the running web is moved into contact with the reserve web roll an appreciable time before the paster is made. Another object is the provision of a web-renewing apparatus in which the application of glue or other adhesive to the reserve web roll is controlled by rotational movement thereof. The invention also provides a novel means for bringing the reserve web roll up to the speed of the running web.

In accordance with the present embodiment of the invention, the reserve web roll is rotatably supported closely adjacent to the running web as it is fed to the printing press or other web-consuming machine. Motor means are preferably provided for initiating rotation of the reserve web roll and bringing it up to the speed of the running web, although the reserve web roll may be speeded up by contact with the running web. Adhesive is applied to the lead end of the reserve web by means of an adhesive coated member or sheet, which is contacted with the lead end of the reserve web roll and is carried thereby into contact with the running web where it causes the joinder of the two webs, and is subsequently carried through the printing press. In a modification of the invention, this adhesive coated member is initially contacted with the running web, and carried by it into contact with the lead end of the reserve web roll. The application of the adhesive-coated member to the running web or the reserve web roll is preferably controlled by rotational movement of the reserve web roll, thereby insuring accurate positioning of the member with respect to the end of the reserve web.

It will be understood that the foregoing general description and the following detailed description as well are exemplary and explanatory of the invention but are not restrictive thereof.

Referring now in detail to the drawings, and in particular to Figures 1 to 7 which illustrate the present preferred embodiment of the invention, the web roll supporting means comprises a conventional form of magazine reel in which the running web roll and reserve web roll or rolls are rotatably supported, and by which successive web rolls may be brought into pasting and running position. As embodied, the multi-armed web roll supporting members are spaced apart

to receive the rotatably mounted web rolls A, B and C between them, and supporting members 1 are rotatably mounted on side frames 2 by means of shaft 3. The ends of arms 1 carry web roll engaging chucks 4 rotatably journaled therein, and projecting inwardly into the axial orifice of the web rolls. The details of this mechanism, including the web tensioning devices, side registering devices and reel arm rotating mechanism are not shown as they form no part of the present invention.

In the drawings, web roll A is the running roll and is shown in running position; web roll B is a reserve web roll in pasting position; and web roll C is a spare roll which will be successively moved into pasting, and then running, position by clockwise rotation of the web roll supporting arms 1.

Motor means are provided for rotating any of the web rolls as they are moved to pasting position and bringing the reserve web roll to the speed of the running web. For this purpose, the arms 1 of the web roll supporting means at one end of the web rolls are each formed with a bracket 6 axially projecting from the arms and on which are mounted individual roll-driving motors 7. Each motor is provided with a pinion 8 meshing with a gear 9 sleeved on the shaft of chuck 4, gear 9 being also provided with a ratchet 10 spring pressed into engagement with ratchet wheel 11 which is fast on the chuck shaft 4 and forms an over-running clutch between the motor and web roll.

The motor 7 for driving the particular web roll in pasting position, receives its power from the source through a commutator arrangement mounted on the supporting shaft 3 and rotatable therewith. As embodied, a sleeve 12 of insulating material is fixed to the shaft 3 and is provided with a pair of conducting rings 14 divided into a plurality of segments, each ring having one segment for each web roll. These segments are connected to their corresponding motors 7 by means of conductors 15, and brushes 16 are mounted on an upright bracket 17 supported on one end frame 2. Brushes 16 contact with the segments 14 and are so positioned that the motor 7, geared to the roll in pasting position, is automatically connected to the source of power as the web roll supporting arms are rotated to position the roll.

If desired, and for the purpose of securing better synchronization between the reserve web roll and the running web, a series resistance 18 may be provided in the motor circuit so that the operator can maintain close control of the web roll speed.

The lead end E of the reserve web roll is joined to the running web by means of a sheet or member 24 coated on both its sides with suitable adhesive, this member being supported adjacent to the reserve web roll and movable into contact with the lead end of the web during the rotation of the reserve web roll.

The adhesive sheet or member is shown in detail in Figure 7, and comprises a flexible sheet of paper or the like, folded upon itself and held in folded relation by lines of adhesive 25, spaced from each other to provide pockets which are open at one end and closed on the sides and end by the lines of adhesive and the fold in the sheet. The external surfaces of the sheet or member are coated with non-drying adhesive 27 which may be of any desired or suitable kind, such as that generally employed for making

pasters. The pockets in the member enable the sheets to be handled freely and to be placed on and easily removed from their supports in the web-renewing mechanism.

For supporting the adhesive members or sheets 24 adjacent to the web roll and later applying them against the surface of the web roll to contact with the lead end of the reserve web, relatively wide flexible fingers are provided and are pivotally mounted above the web roll, suitable means being provided for moving them into contact with the roll. As embodied, a plurality of sets of these fingers are provided which are individually actuated and each set may correspond to quarter widths of the web, thereby permitting any or all to be operated depending upon the width of the web employed.

The fingers 30 comprise relatively wide flexible sheets of metal, attached in pairs to a supporting head 31 pivotally mounted on shaft 31' which is supported in depending brackets 32, each head 31 being provided with a lever portion 33, pivotally connected to the armature 34 of solenoid 35. A spring 36 is provided between the solenoid 35 and arm 33 for normally holding the fingers 30 in raised position out of contact with the surface of the web roll B, and this spring is compressed as the solenoid is energized. Brackets 32 are supported on a cross bar provided at its ends with vertically-movable racks 37, and is guided in grooves 38 on the inner side of supports 39 which depend from the press frame 40. A pair of pinions 41 is rotatably mounted in the supports 39 by shaft 42, to one end of which is attached the lever 43 and operating cord 44 enabling the operator to raise the mechanism out of the path of the web roll as new web rolls are brought into pasting position.

The adhesive coated members 24 are slipped over the resilient supporting fingers 30, the fingers projecting into the pockets between the lines of adhesive 25, and holding the members by frictional engagement.

Means are provided for timing the operation of the fingers 30 to press the adhesive coated members into contact with the lead end of the reserve web. Each of the chuck shafts 4 is provided with a disc 50 of insulating material fixed thereto at its extreme outer end, each of said discs 50 being provided with a conducting portion 51 which rotates with the web rolls. Pairs of brushes 52 and 53 are mounted on an upright 17 secured to the frame 2, and are positioned to contact with the conducting segmental portions 51 of disc 50 as it is rotated by its web roll.

The electrical circuits, shown in Figure 3, may be described as follows: The motor 7 in operative position is connected by its leads 15, segmental rings 14 and brushes 15 to the mains 55 and a manual switch 56 and variable resistance 18 are interposed in the line to control the supply of power to the motor. The pair of brushes 53 are connected in parallel with resistance 57, both of which are in circuit with the winding of solenoid 58 which is connected to mains 55 by line 59 and 60. A push button 61 is provided in line 60 and normally interrupts the supply of current to relay 58. When segment 51 contacts with both brushes 53, resistance 57 is short-circuited and if push button 61 is then closed, current is supplied to the winding of relay 58, thereby moving its armature 62 against contact 63 to close the branch circuit. Resistance 57 will pass sufficient current to the relay to hold armature 62 closed

as long as push button 61 is depressed, and further rotation of the web roll causes segment 51 to contact with both brushes 52, thereby supplying the actuating solenoids 35 with current through lines 64, 65, 66. By correctly positioning the segment 51 with relation to the lead end of the web on reserve web roll B, the application of the adhesive-coated members 24 to the end of the web is insured.

For deflecting the running web into contact with the surface of the reserve web roll B and for pressing the running web against the adhesive coated members or sheets 24, to join the reserve web securely to the running web, a freely rotatable roller 70 provided with a soft resilient covering is supported in pivoted arm 71 so that it may be moved against the running web. While some deflecting means is preferably employed, this is generally not essential and rotational movement of the web roll supporting means may be substituted therefor.

The usual operation of the embodiment just described may be summarized as follows: As the active web roll A nears exhaustion, the operator closes switch 56, thereby energizing the motor 7 for web roll B, and web roll B is gradually speeded up until it attains the speed of the running web. During this interval, the operator places the adhesive-coated members or sheets 24 over their supporting fingers 30, and lowers the fingers into the position shown in Figure 1, where they are closely adjacent to the surface of the reserve web roll.

When web roll A is virtually exhausted, the operator presses roller 70 to deflect the running web into firm contact with the reserve web roll B and while holding the parts in this position, he presses push button 61. As soon as segment 51 contacts with brushes 53, the relay 58 is energized and closes the circuit through contact 63. Brushes 52, on further rotation of the web roll B, are contacted with segment 51, thereby energizing the actuating solenoids 35 and moving the adhesive-coated sheets 24 against the lead end of the reserve web. The adhesion between the sheets and the web causes them to be pulled from their supporting fingers 30 and they are carried around with the web roll to be pressed against the deflected running web. Roller 70 firmly unites the sheet or member 24 to both webs, and the lines of adhesive 25 on the inner sides of the members 24 prevent unfolding of the members.

The operator then releases roller 70, severs the web from the exhausted web roll A in the usual manner, stops the supply of power to motor 7 by opening switch 56 and raises the fingers 30 by means of cord 44. He then rotates the web roll supporting arms to bring web roll C, the next reserve web roll, into pasting position. This same movement moves the roll B into running position, and also connects motor 7, for web roll C, to the mains 55, correctly positioning the timing disc 50 with respect to brushes 52 and 53.

Figure 4 of the drawings shows in a diagrammatic manner the adhesive-coated sheets or members 24 supported on their fingers 30 prior to the pasting operation. As the solenoids 35 are energized, fingers 30 are moved to the position shown in Figure 5 where the sheet 24 is quickly and firmly pressed against the lead end of the reserve web, and is pulled from its supporting fingers 30 by rotation of the web roll. Figure 6 shows the expiring web with the lead end of the reserve web joined to it by the adhesive coated

member or sheet 24 after it has been pressed into firm contact with both of the webs by roller 70.

Instead of bringing the reserve web roll up to the speed of the running web solely by operation of its driving motor 7, the operator may use the motor merely for the purpose of starting the rotation of the web roll, and may then synchronize the reserve web roll and running web by frictional contact between the running web and roll B. In this way the great strain of bringing the reserve roll up to speed from standing position will be materially reduced and the tension of the running web will not be materially affected.

Figures 8 and 9 of the drawings illustrate a modified form of driving means for the reserve web rolls. As shown in these figures, the web roll driving motors 7 are mounted on individual brackets 6 projecting laterally from the web roll supporting arms 1. Each motor 7 is provided with a relatively long shaft 74 rotatably journaled at its end away from the motor in a bearing 75 formed on the web roll supporting arm 1. A centrifugal clutch is provided for coupling the motor to the web roll driving gear 9, thereby relieving the starting load on the motor and permitting the use of a much smaller motor than would otherwise be necessary. This clutch comprises a spider 76 keyed to the motor shaft 74 and received within a clutch drum 77 which is freely rotatable on shaft 74 and connected to pinion 8 of the overrunning clutch by sleeve 78. Clutch blocks 80 are loosely positioned between the vanes 79 of the spider 76 and are held against radial movement by the drum 77. On rotation of the motor, the blocks 80 are moved radially outward by centrifugal force and are pressed into frictional engagement with the drum 77, thereby transmitting the high torque of the motor at nearly full speed to the drum and web roll, while permitting the motor to slip until the web roll has been brought to speed.

Referring now to the modified embodiment of the invention illustrated in Figures 10 to 13 of the drawings, the adhesive carrying member or sheets are applied to the running web instead of the lead end of the reserve web, and their application is timed so that the adhesive coated sheets will register accurately with the lead end of the reserve web as it is pressed into contact with the running web.

In accordance with this embodiment, many of the details of which are identical with those of the previously-described embodiment, the running web is pressed into firm contact with the surface of the reserve web roll B and reserve web roll is brought to the speed of the running web by means of its electric motor 7. The magazine reel end frames 2 are formed with laterally projecting supports 85, having their upper surfaces slightly below the reel shaft 3, and extending horizontally therefrom. On each of these supports 85 is mounted a small bracket 86 in which is rotatably journaled a shaft 87, having its inner end with a relatively deep slot or slat 88 to receive the flattened end of shaft 89. The shafts 87 and their slats 88 are alined and shaft 89 is of just sufficient length to be fitted between them and held by gravity. Rod 89 extends from one side of the web roll supporting mechanism to the other and is positioned to clear the rotating active and reserve web rolls and their supporting arms 1. On shaft 89 are mounted the supporting fingers 30' which are fixed to the shaft and project upwardly therefrom to receive the adhesive coated sheets 24 and position them

closely adjacent to the running web when the shaft is in operative position.

Means are provided for quickly moving the adhesive-coated sheets 24 into contact with the running web by rotation of shaft 89. A lever 90 is fixed to each shaft 87 between its supporting journals 91 and has its lower end pivotally connected to the armature 34' of solenoid 35' also mounted on support 85. A spring 36' is provided between lever 90 and one end of solenoid 35' to hold the fingers 30' normally out of contact with the running web, and is compressed by energization of the armature. The operation of these means is timed by mechanism which may be identical with that diagrammatically illustrated in Figure 3 of the drawings, controlling the supply of power to the solenoids 35' by contact of segments 51 with brushes 52 and 53.

As web roll A nears exhaustion, the operator positions the shaft 89 between the slotted ends 88, thereby supporting the shaft and the adhesive-coated sheets carried thereby adjacent to the running web. After the reserve web roll B has been brought to running speed and the running web has been pressed into firm contact therewith, the operator presses push button 61 to close the solenoid-energizing circuit. Thereafter, the solenoids 35' are energized to press the adhesive-coated members or sheets 24 into contact with the running web which strips them from their supporting fingers 30'. The exact time of actuation of the solenoids 35' is controlled by rotational movement of the reserve web roll B and its timing disc 59. This timing insures that the adhesive-coated members 24 will be applied to the running web in a position to contact with the lead end E of the reserve web roll. The operator may then sever the web from the exhausted web roll A and after removal of the shaft 89 from its supporting sockets, the web roll supporting arms may be rotated to bring the web roll B (now active) from pasting to running position.

The invention in its broader aspects is not limited to the specific mechanisms shown and described but departures may be made therefrom within the scope of the accompanying claims without departing from the principles of the invention and without sacrificing its chief advantages.

What I claim is:—

1. Web renewing mechanism including in combination a support for an active and a reserve web roll, means for moving the reserve web roll from pasting to running position, means for contacting the running web with the reserve web roll, and means for inserting an adhesive sheet between the running web and the reserve web roll.

2. Web renewing mechanism including in combination a support for an active and a reserve web roll, means for moving the reserve web roll from pasting to running position, means for contacting the running web with the reserve web roll, and means for applying an adhesive coated sheet to one of the moving webs to joint it to the other.

3. Web renewing mechanism including in combination a support for an active and a reserve web roll, means for moving the reserve web roll from pasting to running position, means for contacting the running web with the reserve web roll, and means for contacting an adhesive-coated sheet with the running web to joint it to the

reserve web as the running web carries the sheet into contact therewith.

4. Web renewing mechanism including in combination a support for an active and a reserve web roll, means for moving the reserve web roll from pasting to running position, means for contacting the running web with the reserve web roll, means for supporting an adhesive-coated sheet adjacent to one of the moving webs and means for moving the sheet into contact with said one of the webs to joint it to the other.

5. Web renewing mechanism including in combination a support for an active and a reserve web roll, means for moving the reserve web roll from pasting to running position, means for contacting the running web with the reserve web roll, and means for supporting an adhesive-coated sheet adjacent to one of the moving webs, and electro-magnetic means for moving said support to contact the sheet and web.

6. Web renewing mechanism including in combination a support for an active and a reserve web roll, means for moving the reserve web roll from pasting to running position, means for contacting the running web with the reserve web roll, a support for an adhesive-coated member adjacent to the reserve web roll and means for moving said support to contact the member with the lead end of the reserve roll and thereby joint it to the running web.

7. Web renewing mechanism including in combination a support for an active and a reserve web roll, means for moving the reserve web roll from pasting to running position, means for contacting the running web with the reserve web roll, means for supporting an adhesive-coated sheet adjacent to one of the moving webs, electro-magnetic means for moving said support to contact the sheet and web, and means for timing the operation of said last named means with respect to the reserve web roll.

8. Web renewing mechanism including in combination a support for an active and a reserve web roll, means for moving the reserve web roll from pasting to running position, means for contacting the running web with the reserve web roll, means for contacting an adhesive-coated sheet with the running web to joint it to the reserve web as the running web carries the sheet into contact therewith, and means for timing the operation of said last named means by rotational movement of the reserve roll.

9. Web renewing mechanism including in combination a support for an active and a reserve web roll, means for moving the reserve web roll from pasting to running position, means for contacting the running web with the reserve web roll, a support for an adhesive-coated member adjacent to the reserve web roll, means for moving said support to contact the member with the lead end of the reserve roll and thereby joint it to the running web, and means for timing the operation of said last named means by rotational movement of the reserve roll.

10. Web renewing mechanism including in combination a support for an active and a reserve web roll, means for moving the reserve web roll from pasting to running position, means for contacting the running web with the reserve web roll, means for inserting an adhesive sheet between the running web and the reserve web roll, and electrical means for timing the operation of said last named means including a timing disc rotating with the reserve roll.

11. Web renewing mechanism including in

combination a support for an active and a reserve web roll, means for moving the reserve web roll from pasting to running position, means for contacting the running web with the reserve web roll, means for supporting an adhesive-coated sheet adjacent to one of the moving webs, means for moving the sheet into contact with said one of the webs to join it to the other, and electrical means for timing the operation of said last named means including a timing disc rotating with the reserve roll.

12. Web renewing mechanism including in combination a support for an active and a reserve web roll, means for moving the reserve web roll from pasting to running position, means for contacting the running web with the reserve web roll, means for supporting an adhesive-coated sheet adjacent to one of the moving webs, electro-magnetic means for moving said support to contact the sheet and web, and electrical means for timing the operation of said last named means including a timing disc rotating with the reserve roll.

13. Web renewing mechanism including in combination a support for an active and a reserve web roll, means for guiding the web from the active roll adjacent to the reserve roll, means for deflecting the active web into contact with the reserve roll, means for supporting a thin, flexible adhesive member adjacent to but out of contact with the reserve web roll and means for moving said adhesive member into contact with the lead end of the reserve web roll to join it to the active web on rotation of the reserve roll.

14. Web renewing mechanism including in combination a support for an active and a reserve web roll, means for guiding the web from the active roll adjacent to the reserve roll, means for deflecting the active web into contact with the reserve roll, means for supporting an adhesive member adjacent to the reserve web roll, means for moving said adhesive member into contact with the lead end of the reserve web roll to join it to the active web on rotation of the reserve roll, and electrical means for timing the operation of said last named means including a timing disc rotating with the reserve roll.

15. Web renewing mechanism including in combination a rotatable support for an active and a reserve web roll, means for rotating the support to bring the reserve web roll to running position, means for guiding the web from the active web roll adjacent to the reserve web roll, means for deflecting the running web into contact with the reserve web roll, and means for inserting an adhesive sheet between the running web and the reserve web roll.

16. Web renewing mechanism including in

combination a rotatable support for an active and a reserve web roll whereby web rolls may be successively moved from pasting to running position, means for guiding the active web past the reserve web roll and closely adjacent thereto, means for relatively moving the reserve web roll and active web to contact one with the other, means for supporting an adhesive-coated sheet adjacent to one of the moving webs and means for moving the sheet into contact with said one of the webs to join it to the other.

17. Web renewing mechanism including in combination a rotatable support for an active and a reserve web roll whereby web rolls may be successively moved from pasting to running position, means for guiding the active web past the reserve web roll and closely adjacent thereto, means for relatively moving the reserve web roll and active web to contact one with the other, and means for applying an adhesive coated sheet to one of the moving webs to join it to the other.

18. In a web-renewing mechanism, the combination of a support for a reserve web roll, and means for movably supporting a thin, flexible adhesive member adjacent to but out of contact with the web roll so that it may be contacted with the leading end of the reserve web roll.

19. In a web-renewing mechanism, the combination of a support for a reserve web roll, means for supporting a thin, flexible adhesive member adjacent to but out of contact with the web roll and means for contacting the adhesive member with the surface of the web roll.

20. In a web-renewing mechanism, the combination of a support for a reserve web roll, means for supporting an adhesive member adjacent to the web roll, means for contacting the adhesive member with the surface of the web roll and means for timing said contact by rotation of the web roll.

21. The method of making a flying paster which comprises moving the running web into contact with a reserve web roll, rotating the reserve web roll, and applying an adhesive coated member to the leading end of the reserve web roll while the reserve web roll is rotating and firmly pressing the running web against the member to join the webs as the member is presented to the running web by rotation of the reserve web roll.

22. The method of making a flying paster which comprises running the reserve web roll at the speed of the running web, bringing an adhesive coated member between the running web and lead end of the reserve web and pressing the reserve web end and running web into firm contact with the adhesive coated member.

HARLAND FANKBONER.