



(19) **United States**

(12) **Patent Application Publication**
Stoltze et al.

(10) **Pub. No.: US 2004/0098078 A1**

(43) **Pub. Date: May 20, 2004**

(54) **BALLOON WITH REINFORCEMENT AND/OR EXPANSION CONTROL FIBERS**

(75) Inventors: **Jacob Stoltze**, Copenhagen (DK);
Jorgen Kamstrup-Larsen, Allerod (DK)

Correspondence Address:
VIDAS, ARRETT & STEINKRAUS, P.A.
6109 BLUE CIRCLE DRIVE
SUITE 2000
MINNETONKA, MN 55343-9185 (US)

(73) Assignee: **SciMed Life Systems, Inc.**, Maple Grove, MN (US)

(21) Appl. No.: **10/603,297**

(22) Filed: **Jun. 23, 2003**

Related U.S. Application Data

(63) Continuation of application No. 10/375,780, filed on Feb. 27, 2003, which is a continuation of application No. 09/711,034, filed on Nov. 13, 2000, which is a continuation of application No. 08/591,506, filed on Aug. 19, 1996, now Pat. No. 6,187,013, filed as 371 of international application No. PCT/IB95/00492, filed on Jun. 6, 1995.

(30) **Foreign Application Priority Data**

Jun. 6, 1994 (DK)..... 638/94

Publication Classification

(51) **Int. Cl.⁷** **A61F 2/06**

(52) **U.S. Cl.** **623/1.11**

(57) **ABSTRACT**

The present invention relates to a catheter systems for introducing and implanting an expandable stent member in a body. The catheter includes a catheter member having first and second ends, the first end having an inflatable portion, a lumen in fluid communication with the inflatable portion and the second end for inflating the inflatable portion. The expandable stent member is capable of permanent deformation when expanded. At least a portion of the stent member is attached to the inflatable portion by a bond and whereby upon inflation of the inflatable portion the bond is released from the stent member to permit deployment of the stent member and removal of the catheter member. The bond may be formed by the same or different material than the balloon surface. For example, an adhesive may be used. Additionally, the surface of the balloon may be softened and the stent member may be embedded into the softened portion and allowed to return to its original unsoftened state, thereby adhesively connecting the stent to the inflatable balloon.

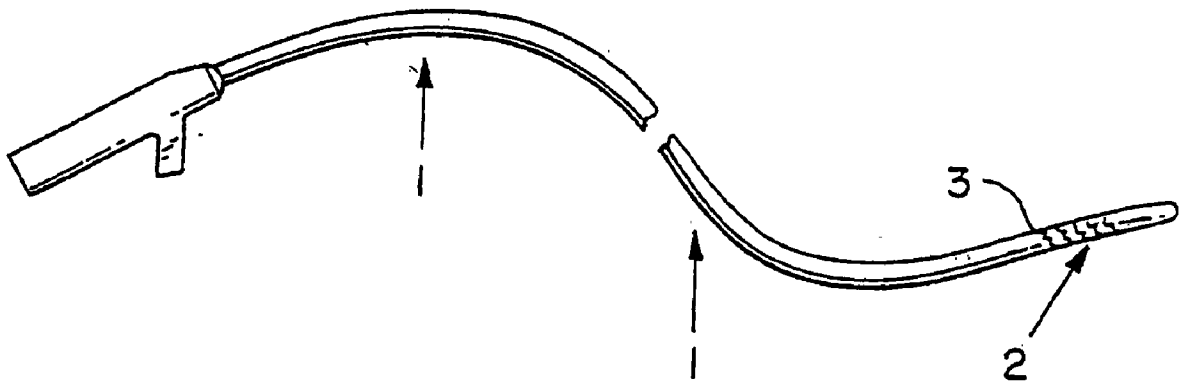

FIG. 1

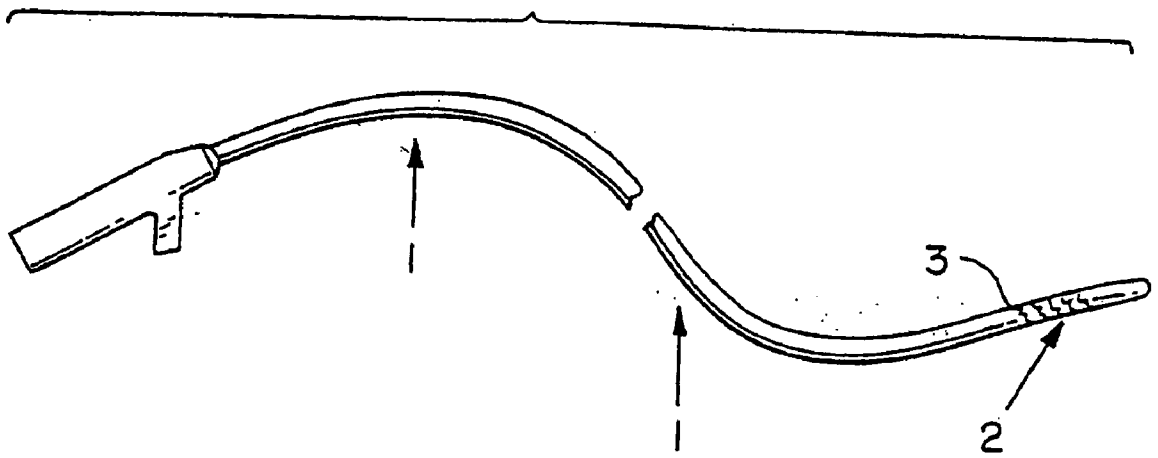

FIG. 2

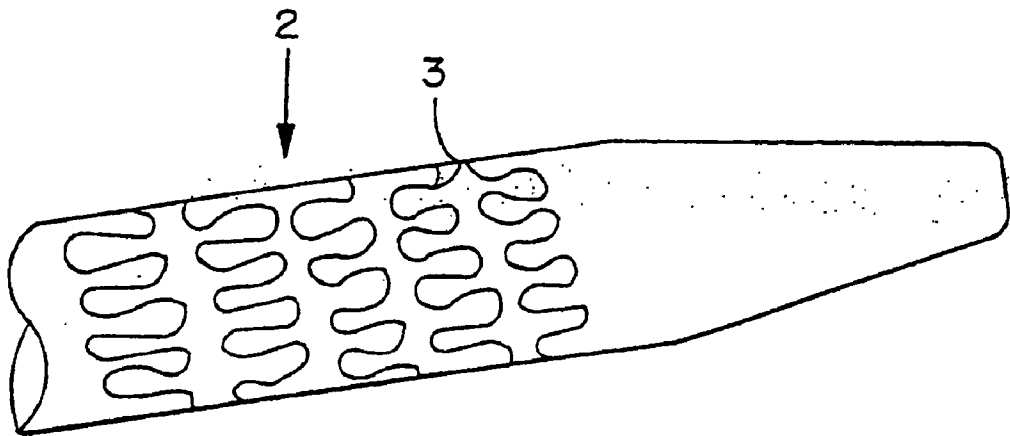

FIG. 3

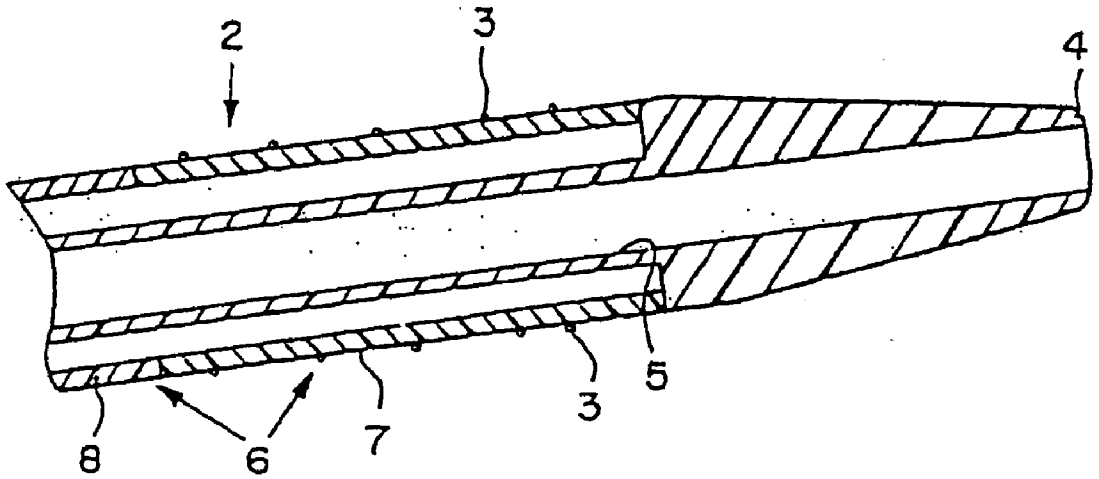

FIG. 4

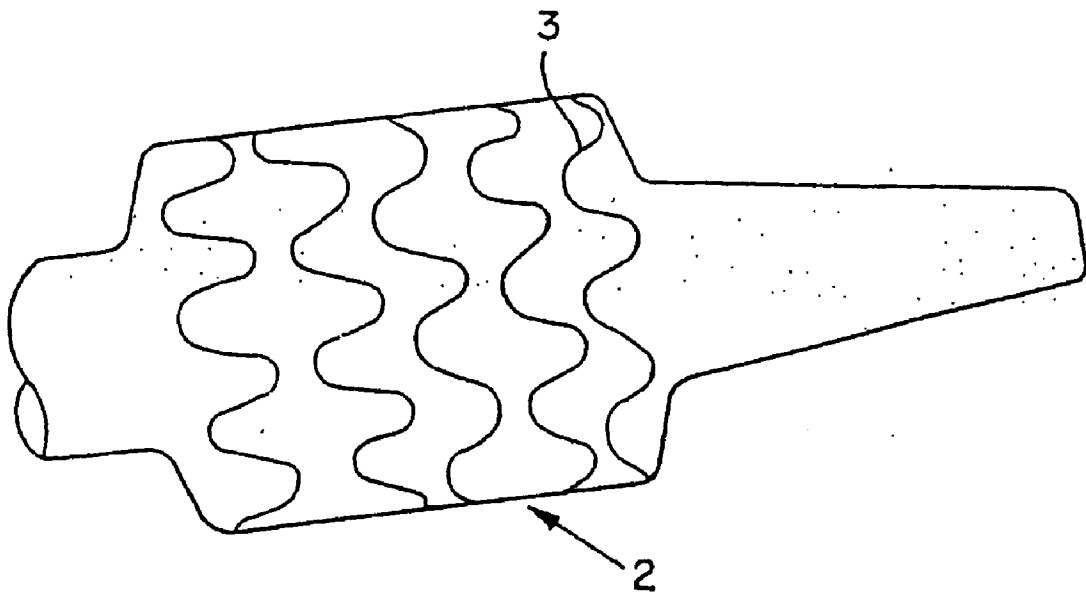

FIG. 5

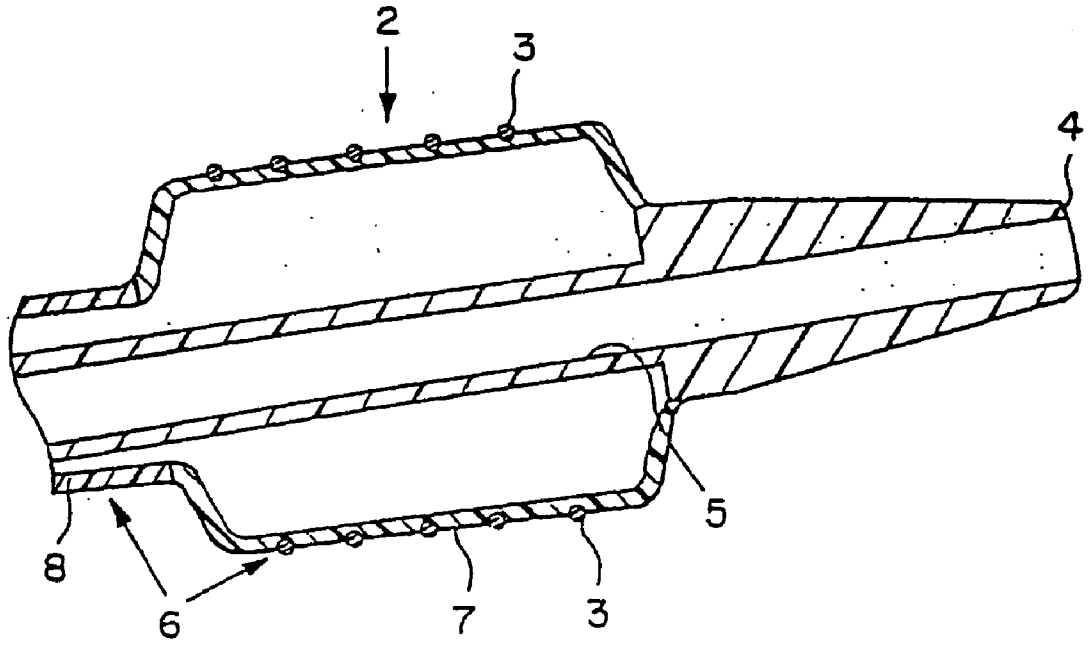

FIG. 6A

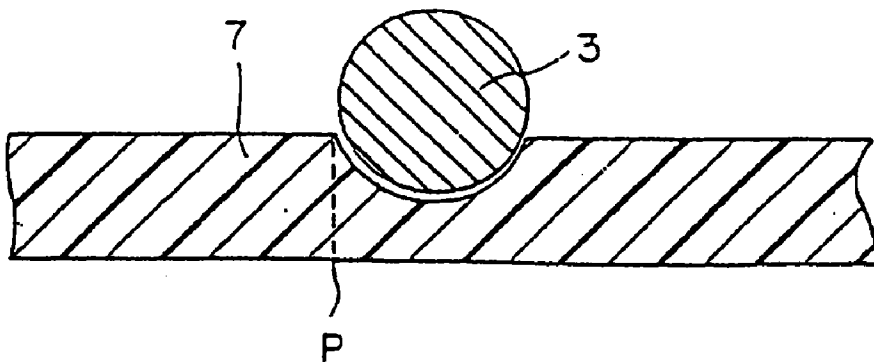

FIG. 6B

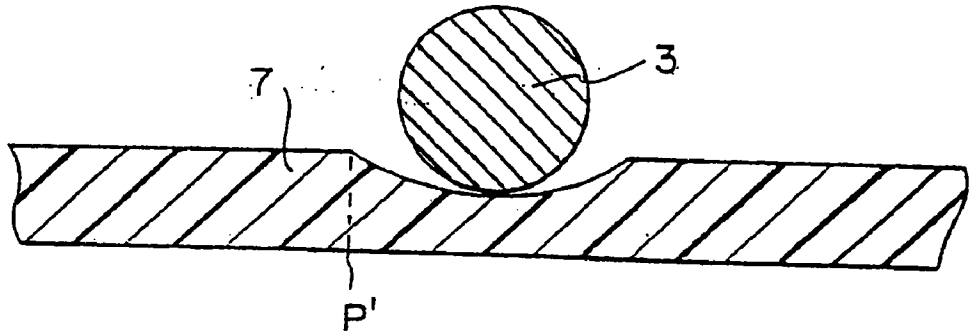

FIG. 7

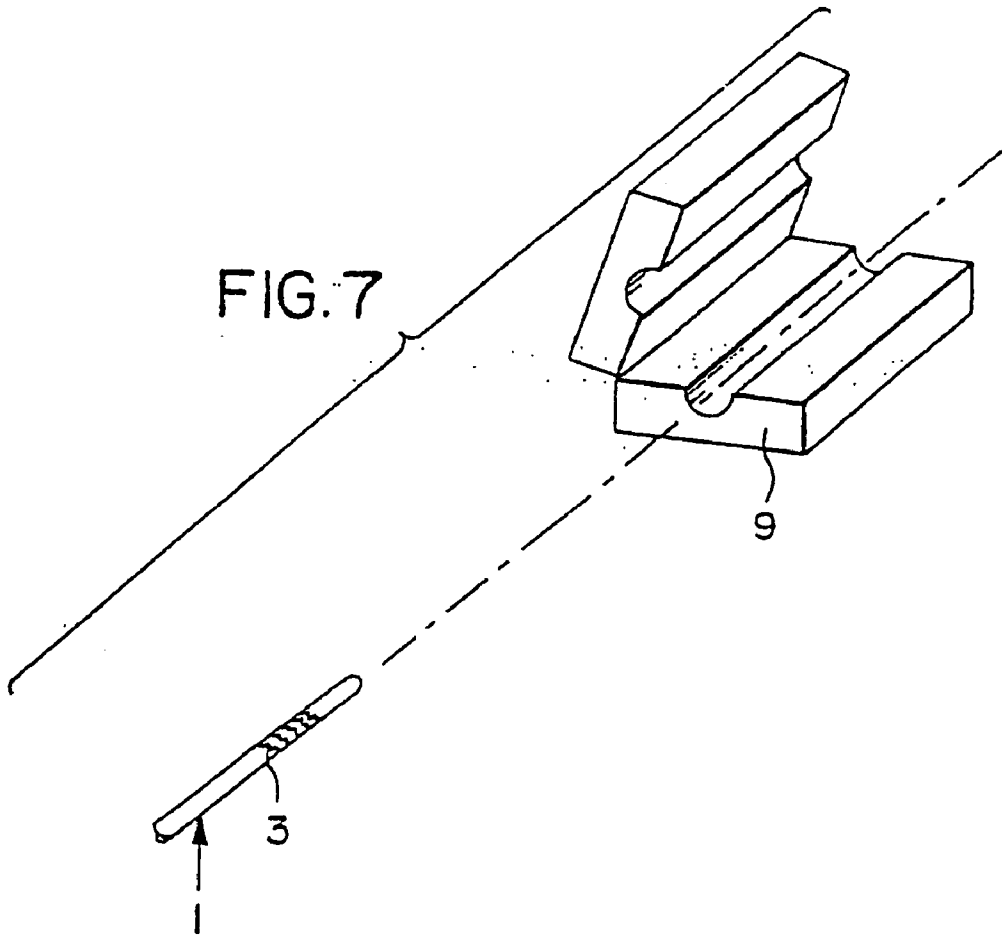

FIG. 8A

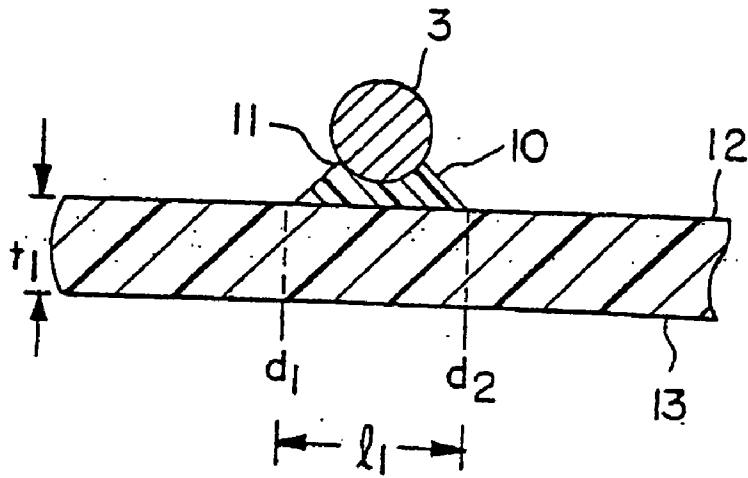
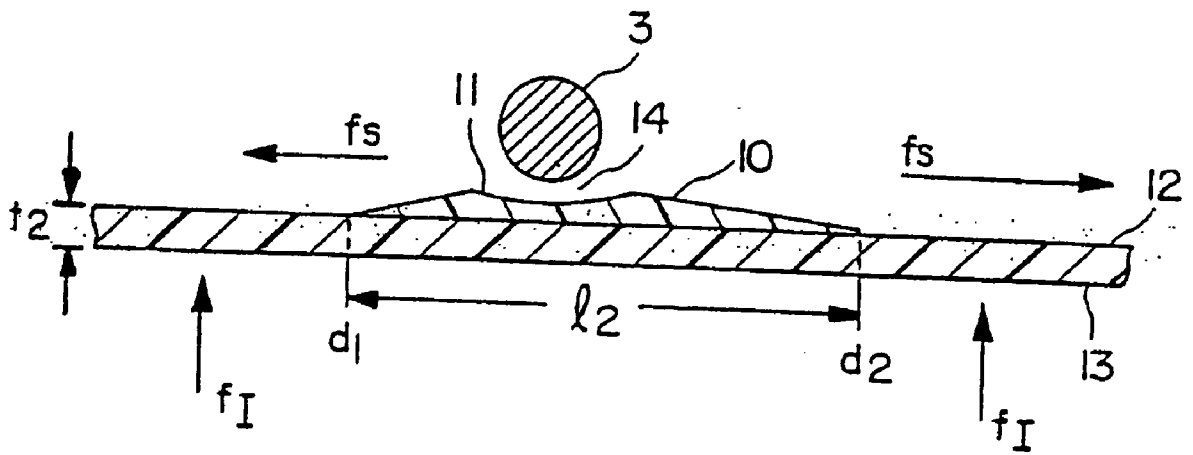

FIG. 8B



BALLOON WITH REINFORCEMENT AND/OR EXPANSION CONTROL FIBERS**CROSS REFERENCE TO RELATED U.S. PATENT APPLICATIONS**

[0001] This application is a continuation of copending U.S. patent application Attorney Docket No. 760-46/CIP/PCT/USA/CON3 filed Feb. 27, 2003; which is a continuation of U.S. patent application Ser. No. 09/711,034 filed Nov. 13, 2000; which is a continuation of PCT/IB95/00492 filed Jun. 6, 1995, designating the U.S., U.S. National Stage application Ser. No. 08/591,506 now issued as U.S. Pat. No. 6,187,013; which claims priority from Denmark Application No. 638/94 filed Jun. 6, 1994, each of which is incorporated by reference herein in its entirety.

BACKGROUND OF THE INVENTION

[0002] The present invention relates to a catheter system for introducing and implanting a stent and comprising a catheter having at its one end an expandable portion, at its opposite end elements intended for communication with means for expanding the expandable portion, and a stent made of a material to which a permanent deformation for maintaining an enlarged transverse dimension is imparted when the catheter is expanded, said stent being arranged around the expandable portion of the catheter and releasably fixed to the catheter to prevent movement of the stent during insertion.

[0003] In case of partially occluded blood vessels, e.g. due to arteriosclerosis, it was previously necessary to perform surgery directly at the site of occlusion to cure a patient suffering from this kind of disorder. Such partial occlusion may be dilated by introducing a catheter with an expandable portion into the blood vessel and expanding the expandable catheter portion in the partially occluded area. However, this is not always sufficient since the partially occluded portion may be reestablished or relapse to its partially occluded state. In recent years it has become increasingly common to treat such cases by implantation of a stent (an endoprosthesis) into the partially occluded portion of a blood vessel. Following implantation, the stent influences the blood vessel to the effect that the latter stays dilated. In most instances, the patient will avoid more severe consequences of such disorder in the future.

[0004] Various types of catheters with expandable portions are available. A first type is designed with a portion which, under the influence of pressure, is expanded by elastic deformation of the expandable portion. This type is most often designated balloon catheters. A particular embodiment of such catheter is disclosed in UK 156674. This catheter comprises a reinforcement web in its expandable portion, said reinforcement web having a rhomb pattern. Expansion of the expandable portion of such catheter entails simultaneous reduction of the length of said portion.

[0005] A second type of catheter is made of a substantially non-elastomeric material and provided with elements which are, in the unexpanded state of the catheter, for instance rolled/folded around the remaining catheter assembly. Pressure influences will cause the expandable portions to unfold.

[0006] Stents, too, are available in various embodiments. Distinction is made between pressure-expandable stents and

auto-expandable stents. The stent type relevant to the present invention is the pressure-expandable one to which pressure influences from the catheter imparts a permanent deformation until the desired introduction diameter has been reached. An example of such stent is known from EP 312852. The stent disclosed therein is a stent made from a coherent thread.

[0007] The implantation of such stent is effected by means of a catheter provided with an expandable portion onto which the stent is arranged. The catheter with the stent is introduced e.g. in the groin region if the stent is to be lodged in a blood vessel in a leg, and it is guided under x-ray monitoring to the partially occluded site whereupon means connected to the catheter applies a pressure to said catheter and the expandable catheter portion urges the stent out towards the blood vessel wall. The pressure is subsequently reduced and the catheter may then be withdrawn from the blood vessel whereas the stent in its expanded state remains in the blood vessel portion which requires treatment. The operation is relatively simple compared to the surgical intervention otherwise required at the partially occluded site and thus it is desirable in many situations.

[0008] The use of balloon catheters to deliver various types of stents has become widely used in the medical field. Such relatively non-invasive techniques offer many advantages to both patient and surgeon. Notwithstanding the advances made in this area, several problems still exist with respect to preventing the stent from unwanted movement on the uninflated balloon during insertion, placement, and final positioning of the stent prior to expansion and full deployment. Often the stent moves relative to the balloon during its negotiation through tortuous vessels and becomes off-centered on the inflatable balloon, such that it incompletely or improperly expands. In a worst case scenario, the balloon may move such that its expansion and proper positioning are not possible. For example, EP-A-0442657 discloses a catheter system of the type described above where the stent is arranged around the expandable catheter portion and where collars or sleeves are mounted on the catheter serving only to secure the stent at its end portions.

[0009] Owing to its collars, this known catheter system has a relatively large diameter. Moreover the catheter system is associated with the drawback that there is a risk of the stent moving away from the catheter surface during introduction of the catheter system through the small bending radii of a blood vessel, thereby causing damage to the blood vessel.

[0010] U.S. Pat. No. 4,950,227 discloses a similar system wherein, however, an alternative stent embodiment is used, viz. the so-called "knitted stent", whereby the risk of the stent moving away from the catheter surface is reduced but not completely eliminated. Like the above-described catheter system, however, the catheter system known from this U.S. patent is disadvantageous, too, due to the use of collars for mechanical securing of the stent and the ensuing increased outer diameter.

[0011] Efforts to solve the unwanted movement of the stent during insertion have included using adhesive to bond the stent to the balloon. For example, U.S. Pat. No. 5,100,429 employs a photo-degradable adhesive to bond the balloon to the stent. Light is then used to degrade the adhesive once the stent is inserted into the body. In this

disclosure the stent used is of the type which is rolled around the catheter assembly which means that the aggregate system has a relatively large cross section at this point. Thereby the fields of application of the system are restricted. Moreover, practice has shown that there will always be residues of adhesive left on the implanted stent, which residue is to be degraded so as not to cause occlusion of the blood vessel. Thereby the implantation is rendered more difficult and the system presupposes particular adhesives, e.g. a light-degradable adhesive, and means, e.g. a light source, in connection with the catheter to degrade the adhesive.

[0012] The fact that thus the known catheter systems which incorporated stents have relatively large transverse dimensions due to their having portions which overlap the stent ends or optionally the entire stent, or due to the stent being rolled around the catheter assembly, the fields of application of such catheter systems are restricted. Moreover, there is a certain risk associated with the known systems that adhesive residues adhere to the implanted stent.

[0013] It is therefore one object of the invention to provide a catheter system of the type which in a simple manner ensures reliable securing of the stent against the catheter and simultaneously allows such catheter system to be designed with a substantially reduced transverse dimension compared to the prior art and without the risk of adhesive residues or catheter materials sticking to the implanted stent.

SUMMARY OF THE INVENTION

[0014] This is obtained with a catheter system which is characterized in that the stent is adhesively connected to the expandable catheter portion with adhesive forces between stent and support which are less powerful than the shear forces applied by the expandable portion which influence the adhesive connection when this portion is expanded. The stent is releasably connected at the bondline to the expandable portion of the catheter by adhesion forces which are weaker than the shear forces created at the bondline when the expandable portion is expanded and whereby said bondline adhesively fails at the stent surface, i.e. stent/adhesive interface, during expansion to release said stent. The term "adhesively fails" as used herein is meant to indicate failure at the interface and not in the matrix of the adhesive per se.

[0015] Thus, the adhesive communication may be formed by use of a suitable adhesive or through softening of the catheter surface and subsequent positioning of the stent thereon.

[0016] According to a particularly suitable embodiment of the invention, the stent is at least partially depressed into the catheter surface in the expandable catheter portion in its unexpanded state. Thereby the further advantage is obtained that the depression formed by depressing the stent into the catheter surface prevents axial displacement of the stent relative to the catheter and the transverse dimension of the catheter system is further reduced.

[0017] The idea of using adhesives to bond the stent to the balloon has inherent problems with respect to adhesive residue which may be left behind once the bond is broken. Such residue, even if biodegradable over time, may present problems and cause blockage in smaller vessels, as well as other side effects.

[0018] The present invention seeks to offer a solution to securing the stent to the inflatable portion of the catheter,

such that a releasable bond is formed without the risk of adhesive residue. In one embodiment, the bond is formed by the same material as the inflatable portion of the balloon. This can be achieved by softening the exterior wall of the balloon and depressing the stent into the softened, inflatable wall and allowing the softened material to adhere to the stent. The formation of such a bond is, in effect, a hot-melt joint. This bond can be effected with a number of different types of stents, including wire stents or cage stents, as well as porous tubular stents. The bond joint may occur at each point of contact between the stent and the balloon surface, or it may be formed at preselected, spaced apart contact points.

[0019] In another embodiment, a separate adhesive material, being the same or different from the material comprising the balloon wall, may be employed. In this case, however, it is necessary that the adhesive material have a modulus of elasticity which is substantially similar to the modulus of the balloon. This is to allow the adhesive to remain stationary relative to the balloon during expansion of the balloon and release itself from the stent without leaving residue. While it is not necessary that the moduli between the adhesive and the inflatable portion (balloon) be exactly the same, it is preferred that the degree of difference between the adhesive modulus of elasticity and the stent modulus of elasticity be maximized and the differential between the modulus of the inflatable balloon and that of the adhesive be minimized.

[0020] This requirement is to prevent the adhesive from shearing from the balloon during expansion and remaining on the stent once it is deployed. If the adhesive has a modulus of expansion which is much closer to the modulus of the balloon than of the stent, the adhesive will have a tendency to remain stationary with respect to the balloon but will move at the bondline joint with respect to the stent. This can further be illustrated with respect to **FIGS. 8A and 8B**. At a given contact surface between the stent and the wall surface of the balloon, various contact points can be identified. During expansion, all of these points begin to move nearly simultaneously in a shear direction. If the modulus of elasticity of the adhesive is such that the adhesive points do not move relative to the balloon, i.e., expand with the balloon, the shear forces will not lift the adhesive from the balloon surface and the adhesive will remain attached to the wall. However, at the bondline interface between the stent and the adhesive, the points of contact are now moving relative to each other and the bond will then be overcome by the shear forces and be released from the stent, thereby freeing the stent from adhesive and permitting deployment of the stent into the vessel without adhesive residue. If the differences between the moduli of the stent and the adhesive are great enough, the release of the bond between these components can easily be effectuated, since all the points of contact will substantially move simultaneously. This principle can be illustrated in simplified fashion through the use of an adhesive bandage on the skin. If the adhesive bandage is removed by peeling very slowly, it is difficult and painful to remove. However, if the adhesive bandage is elastomeric and can be stretched, it can be easily removed by stretching its ends in opposite directions, thereby applying shear forces at opposite ends. In this manner, the bandage lifts very easily, without pulling the skin and with a nominal amount of force. This is because all the points of adhesive contact are moving relative to the skin which remains stationary.

[0021] The present invention seeks to take advantage of such principles by providing a catheter system which includes a catheter member having an inflatable portion and a stent member which is capable of permanent deformation when expanded and which is releasably attached to said inflatable portion by a bond, whereby upon inflation of said inflatable portion, the bond is released from the stent to permit deployment of the stent member into the body.

[0022] In the present invention the incorporation of additional elements, e.g. collars, for mechanically securing the end portions of the stent or optionally the entire stent assembly is avoided and the entire catheter system may thus be constructed with substantially smaller transverse dimensions, i.e. diameter, than the prior art, which is of considerable importance when introduction into the patient of the catheter with its integral stent is effected through an introducer sheath, thereby also making it possible to subsequently select an introducer sheath with a smaller diameter. The size of the introducer sheath is crucial to the expediency of the patient's recovery and discharge from the hospital following treatment. As a consequence of this reduction of the required hospitalization period, the option that a narrower introducer sheath may be used both contributes to the well being of the patient and rationalizes the operation of the hospital.

[0023] In one embodiment, the present invention includes a catheter system for introducing and implanting a stent in a body, said system including a catheter member having first and second ends, said first end having an inflatable portion, a lumen in fluid communication with said inflatable portion and said second end to provide means for inflating said inflatable portion; and an expandable stent member capable of permanent deformation when expanded, at least a portion of said stent member being attached to said inflatable portion by a bond, whereby upon inflation of said inflatable portion said bond is released from said stent member to permit deployment of said stent member and removal of said catheter member.

[0024] The bond may comprise an adhesive which must be selected from among those which has a modulus of elasticity such that upon expansion of the catheter's expandable or inflatable portion, the bond, i.e., adhesive connection, between the inflatable portion (balloon) and the adhesive itself, is influenced or subjected to a weaker force at the balloon/adhesive bondline than the force which is influencing the stent/adhesive bondline. By selecting such an adhesive for this purpose, it is ensured that the adhesive will remain on the catheter surface during implantation of the stent. The selection of an appropriate adhesive can be made on the basis of the modulus of elasticity. By selecting an adhesive with a modulus of elasticity which more closely approximates the modulus of elasticity of the inflatable portion of the catheter, very little shear force will be placed on the balloon/adhesive bondline (interface) during balloon expansion. A relatively higher shear force will be experienced, however, at the stent/adhesive bondline due to the large differences in the modulus of elasticity between the stent and the adhesive per se.

[0025] Although the adhesive may be selected from a material which is different from that of the balloon, it is preferred to form the adhesive bond using the balloon material per se. This is accomplished by softening the

balloon material, depressing the stent into the softened area and allowing the balloon material to adhere at the points of contact. As previously described, this adhesive connection is essentially a hot-melt joint whereby the stent releasably bonds to the balloon. In this instance, since no separate or additional adhesive is used to form the bond, there is no residue which remains once the balloon expansion releases the stent. In this embodiment, the modulus of elasticity of the balloon and the adhesive are substantially identical since they are the same material. Their moduli are significantly smaller than that of the stent. Thus, the differential between the stent and balloon moduli are maximized to produce the desired result.

[0026] The stent is advantageously depressed into the catheter surface in the expandable portion in a depth corresponding to from one twentieth to one half of the stent material thickness and more advantageously from one tenth to one third.

[0027] Moreover the invention relates to a method of producing a catheter system for the introduction and implantation of a stent which catheter system comprises a catheter with an expandable portion at its first end and a plastically deformable stent arranged around the expandable catheter portion.

[0028] The method includes the steps of positioning the stent around the expandable catheter portion, softening the surface of the expandable catheter and applying pressure to the stent to obtain at least partial depression into the catheter surface.

[0029] A particularly simple way of doing this is by arranging the catheter carrying the stent on the inflatable catheter portion in a device which encloses the stent and introducing a fluid under pressure into the catheter through the elements intended therefor at the opposite end of the catheter so as to expand the expandable catheter portion and urge the stent towards the inside of the device whereby the stent is depressed into the catheter surface.

[0030] The fluid pressure in the catheter is then subsequently reduced whereby the cross section of the expandable catheter portion is concurrently reduced and the catheter bearing the depressed stent may be removed from the device.

[0031] The method described above is thus both simple and efficient for the production of catheters according to the invention where the stent is depressed into the catheter surface.

[0032] In another embodiment, a separate adhesive is used to join the stent and inflatable portion. The adhesive is selected to form a bond which releases only at the stent/adhesive interface and not at the balloon/adhesive interface.

[0033] The softening of the catheter surface may for instance be effected by application of a solvent. However, it is particularly advantageous to soften the catheter surface by heating, this process being easily controllable. When the softened catheter surface resumes its stable state, the stent will moreover adhere to the catheter material which contributes further to the securing of the stent during introduction of the catheter into a blood vessel. When an adhesive is applied the catheter surface may be constituted of such an adhesive layer.

BRIEF DESCRIPTION OF THE DRAWINGS

[0034] The invention will now be described in further detail with reference to the drawings, wherein

[0035] **FIG. 1** is an overall view of the catheter system according to the invention.

[0036] **FIG. 2** is a more detailed view of the expandable portion of a catheter in its unexpanded state and having a stent secured thereto.

[0037] **FIG. 3** is a sectional view through a catheter in its longitudinal direction and at the expandable portion.

[0038] **FIG. 4** shows the catheter and the stent corresponding to **FIG. 2** where, however, the catheter is expanded.

[0039] **FIG. 5** is a sectional view through a catheter at its expandable portion where the catheter is expanded.

[0040] **FIGS. 6A and 6B** are more detailed sectional views through a section of a catheter where a stent is depressed into the catheter surface and shown in the unexpanded and expanded states, respectively.

[0041] **FIG. 7** is a schematical view of a useful device for bonding the inflatable portion of the catheter to the stent.

[0042] **FIGS. 8A and 8B** are schematic sectional views taken longitudinally through a catheter at its expandable portion showing the use of a separate adhesive bonding the stent to the balloon.

DESCRIPTION OF THE PREFERRED EMBODIMENTS

[0043] **FIG. 1** shows one embodiment of the catheter system according to the invention. The catheter system comprises a catheter **1** with an expandable portion **2** at its first end, a stent **3** arranged around the expandable catheter portion, and elements at the opposite end of the catheter intended for communication with means for expanding the expandable portion **2**.

[0044] **FIG. 2** is a more detailed view of the stent **3**. The stent is made of a coherent metal thread. This thread is curved and thus it appears as a band coiled around the catheter whereby a tubular stent **3** is formed.

[0045] **FIG. 3** shows the construction of a catheter **1** which in a manner known per se is provided with an expandable portion. Herein, the introduction end **4** of the catheter and an inner tubular member **5** is formed integrally. The introduction end **4** is open between its tip and the tubular member **5**. Hereby a guide wire (not shown) may be used for the introduction of the catheter into a blood vessel. Around and at a distance from the inner tubular member **5** an outer tubular member **6** is arranged. The outer tubular member is made partly of an elastically deformable material **7**, preferably a thermoplastic elastomer, partly of a non-deformable material **8**.

[0046] When the elements at the opposite end of the catheter are connected to e.g. a fluid pressure source, fluid under pressure will enter the space between the inner and the outer tubular member and thereby cause the elastomeric material **7** to be extended and the cross section of the catheter to be increased as will appear from **FIG. 4**. At the same time the stent material is deformed as the curves are

moved away from each other. **FIG. 5** shows a section through a catheter in the state shown in **FIG. 4**.

[0047] **FIG. 6A** shows how the stent **3** is depressed into the surface of the elastically deformable catheter material **7** in an unexpanded state of the catheter. Since the catheter material **7** is extended under the influence of pressure, the partially circular depression formed in the catheter surface and shown in **FIG. 6A** will be so deformed that the contact face between catheter and stent is reduced as indicated in **FIG. 6B**. It is outlined schematically that a point P, which in an unexpanded state is situated immediately adjacent to the stent thread, is situated a distance from the stent thread at P' in the expanded state of the catheter. Thus, partial displacement of the contact elements is effected relative to the stent and the catheter surface, respectively. Discontinuation of the pressure influence and the ensuing reduction of the catheter cross section leaves the stent in its expanded state as will appear from **FIG. 4**.

[0048] **FIG. 7** shows an end portion of a catheter where a stent is arranged around an expandable catheter portion, while the stent is not yet depressed into the catheter surface. According to a preferred embodiment of the method according to the invention the catheter **1** and the stent **3** are introduced into a heating device **9**. The temperature in the heating device is maintained at from 50° C. to 250° C., preferably about 150° C., and after a certain period of time depending on the actual temperature, the catheter surface will be softened. The elements at the opposite end of the catheter are connected to e.g. a fluid pressure source and fluid under pressure causes the expandable portion of the catheter to expand and to urge the stent towards the inner wall of the device whereby the stent is depressed into the catheter surface. When the pressure is reduced, the cross section of the catheter will be reduced whereupon the catheter and the stent may be removed from the device. When the catheter surface is softened and the stent subsequently depressed into the surface, an adhesive connection between catheter and stent is also obtained which contributes further to secure that the stent is fixed relative to the catheter during introduction into a blood vessel. The expansion occurring during mounting of the stent in the catheter surface is of a range which causes only elastic deformation thereof. Thus, any expansion of the stent during this mounting process reverses itself to the non-expanded state once the thus formed catheter system is removed from the fixture.

[0049] **FIG. 8A** shows the unexpanded balloon and **FIG. 8B** shows the expanded balloon with the inflation forces f_1 and shear forces shown with directional arrows at the bondline interface between the adhesive and stent. **FIG. 8A** represents an embodiment of the present invention showing the use of a separate adhesive in the form of a fillet **10** which defines a bondline at interface **11** between stent **3** and fillet **10**. The adhesive forms the connection between stent **3** and the external surface of balloon **12**. In this view, the balloon is in an unexpanded state, i.e. deflated. The external surface **12** and the internal surface **13** of the balloon define a thickness t_1 which is the thickness of the inflatable balloon. Two points are marked on the balloon surface as d_1 and d_2 . The distance between these two points, which are positioned at the corners of the adhesive fillet **10**, is defined as 1_1 indicating the starting length between the two points. During inflation as depicted in **FIG. 8B**, inflationary force f_1 is applied to the internal surface **13** of the balloon such that

expansion is initiated. Simultaneously, as the balloon stretches, shear forces f_s exist at the bondlines of the adhesive connection. The elastomeric adhesive forming fillet **10** has been chosen to have an elastic modulus such that it expands along with the balloon. During the expansion, the thickness of the balloon is diminished to t_2 (less than t_1) and the shear forces which act throughout the adhesive connection separate at bondline **11** causing the release of the stent from the adhesive and leaving a gap **14** such that the balloon can be removed to allow permanent fixture of the stent **3** in the body. No adhesive residue remains on the stent during the expansion of the balloon. There is less movement between the adhesive and the balloon interface than between the stent and adhesive interface, thereby indicating that less force is required at bondline **11** to release the stent since adhesive **10** and stent **3** were in movement relative to each other during the expansion process.

[0050] The material from which the expandable portion of the catheter is made may be chosen from a number of thermoplastic elastomeric polymers which are capable of being inflated. Preferably, however, the expandable balloon is made from polyurethane.

[0051] The balloon may take a number of configurations and shapes designed to perform in various ways. Additionally, reinforcement and/or expansion control fibers may be provided to the balloon. Generally, these fibers are embedded in the matrix of the balloon in a helical pattern such that they will prevent expansion beyond a pre-specified limit. These fibers are generally selected from a non-elastomeric thermoplastic material such as polyethylene or polyethylene terephthalate. One example of such a reinforced balloon is described in U.K. Patent No. 1,566,674 whereby a reinforcement web is embedded in the expandable balloon. In the balloon's inflated state, the reinforcement web has a rhomb or helical configuration where one rhomb axis is substantially parallel with the catheter axis to which the balloon is attached. Expansion of the expandable catheter portion causes the rhombs to change their axis length such that in the uninflated (unloaded) state, the length of the second transverse axis in its fully expanded state will be increased.

[0052] This means that the length of the expandable catheter portion is reduced, i.e. that an axial movement occurs during expansion whereby the stent length is reduced corresponding to the length reduction of the expandable catheter portion, whereby the release of the stent from the catheter is further promoted. This expansion also contributes to the partial displacement of the contact faces as explained above in connection with **FIGS. 6A and 6B**. However, other catheters will also be suitable for use in connection with the catheter system according to the invention. Moreover, it is also possible to use all types of balloon-expandable stents.

1. A dilatation balloon comprising fibers in a matrix material.
2. The dilatation balloon of claim 1 wherein said fibers are reinforcement fibers.
3. The dilatation balloon of claim 1 wherein said fibers are expansion control fibers.
4. The dilatation balloon of claim 1 wherein said fibers are embedded in the matrix material of the balloon.

5. The dilatation balloon of claim 4 wherein said fibers are embedded in the matrix material of the balloon in a helical pattern.

6. The dilatation balloon of claim 1 wherein said fibers are thermoplastic.

7. The dilatation balloon of claim 6 wherein said fibers are non-elastomeric.

8. The dilatation balloon of claim 6 wherein said fibers are selected from the group consisting of polyethylene, polyethylene terephthalate and mixtures thereof.

9. The dilatation balloon of claim 1 wherein said matrix material is thermoplastic.

10. The dilatation balloon of claim 9 wherein said matrix material comprises an elastomer.

11. The dilatation balloon of claim 1 wherein said matrix material comprises polyurethane.

12. The dilatation balloon of claim 1 where said matrix material is non-elastomeric and said fibers are elastomeric.

13. The dilatation balloon of claim 1 further in combination with a catheter assembly, a stent or a combination thereof.

14. A catheter system for introducing and implanting a stent member in a body comprising a catheter member having first and second ends, said first end having an inflatable portion comprising a matrix material and fibers, a lumen in fluid communication with said inflatable portion and said second end to provide means for inflating said inflatable portion.

15. The catheter system of claim 14 further in combination with a stent.

16. The catheter system of claim 14 wherein said fibers are reinforcement fibers.

17. The catheter system of claim 14 wherein said fibers are expansion control fibers.

18. The catheter system of claim 14 wherein said fibers are embedded in the matrix material of the inflatable portion.

19. The catheter system of claim fibers are embedded in the matrix material of the inflatable portion in a helical pattern.

20. The catheter system of claim 14 wherein said fibers are thermoplastic.

21. The catheter system of claim 20 wherein said fibers are non-elastomeric.

22. The catheter system of claim 14 wherein said fibers are selected from the group consisting of polyethylene, polyethylene terephthalate and mixtures thereof.

23. The catheter system of claim 14 wherein said inflatable portion is formed from a thermoplastic elastomer.

24. The catheter system of claim 14 wherein said inflatable portion is formed from polyurethane.

25. The catheter system of claim 14 wherein said inflatable portion is formed of a non-elastomeric material enclosed within an elastomeric material.

26. The catheter system of claim 14 further comprising an expandable stent member capable of permanent deformation when expanded.

27. The catheter system of claim 14 wherein at least a portion of said stent member is releasably attached to said inflatable portion by a bond.

* * * * *