



(19) **United States**

(12) **Patent Application Publication**
Balthes

(10) **Pub. No.: US 2003/0162461 A1**

(43) **Pub. Date: Aug. 28, 2003**

(54) **PROCESS, COMPOSITION AND COATING OF LAMINATE MATERIAL**

(60) Provisional application No. 60/358,857, filed on Feb. 22, 2002. Provisional application No. 60/359,017, filed on Feb. 22, 2002. Provisional application No. 60/359,602, filed on Feb. 26, 2002. Provisional application No. 60/400,173, filed on Jul. 31, 2002.

(76) Inventor: **Garry E. Balthes, Elkhart, IN (US)**

Correspondence Address:
BARNES & THORNBURG
600 ONE SUMMIT SQUARE
FORT WAYNE, IN 46802

Publication Classification

(51) **Int. Cl.⁷** **D04H 5/06**; D04H 1/00;
D04H 5/00; D04H 13/00;
D04H 1/54; D04H 3/14
(52) **U.S. Cl.** **442/411**; 442/327; 442/409;
442/414; 442/416; 442/417

(21) Appl. No.: **10/366,973**

(22) Filed: **Feb. 14, 2003**

(57) **ABSTRACT**

Related U.S. Application Data

A fibrous moldable substrate is provided having a fibrous material and a binder. The fibrous material and binder is subjected to heat such that only a portion of the binder is wetted to the fibrous material.

(63) Continuation-in-part of application No. 10/287,250, filed on Nov. 4, 2002.

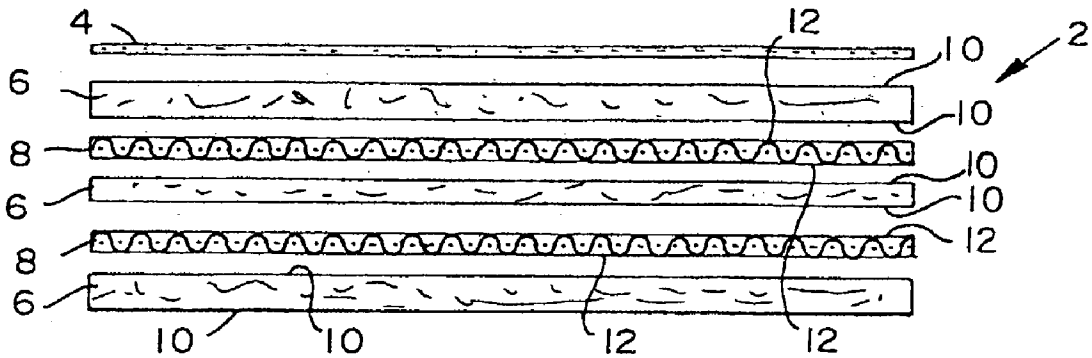

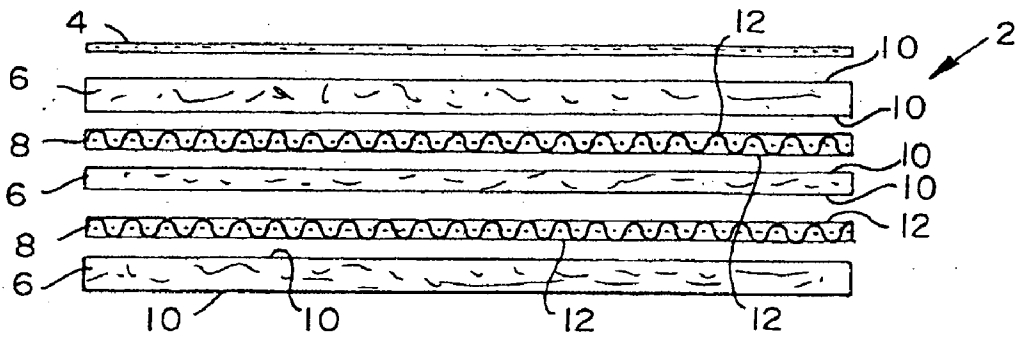

FIG. 1

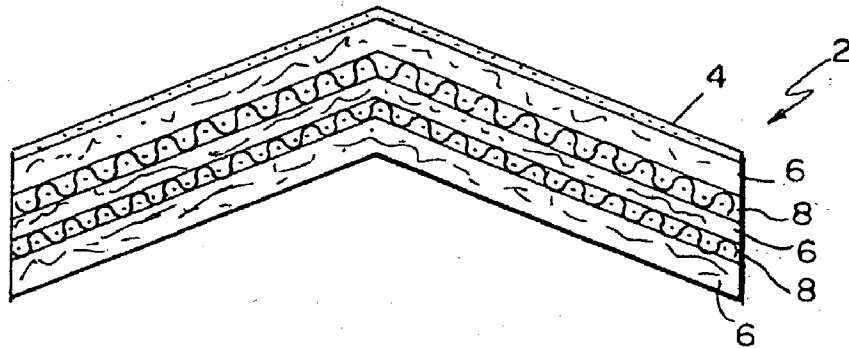

FIG. 2

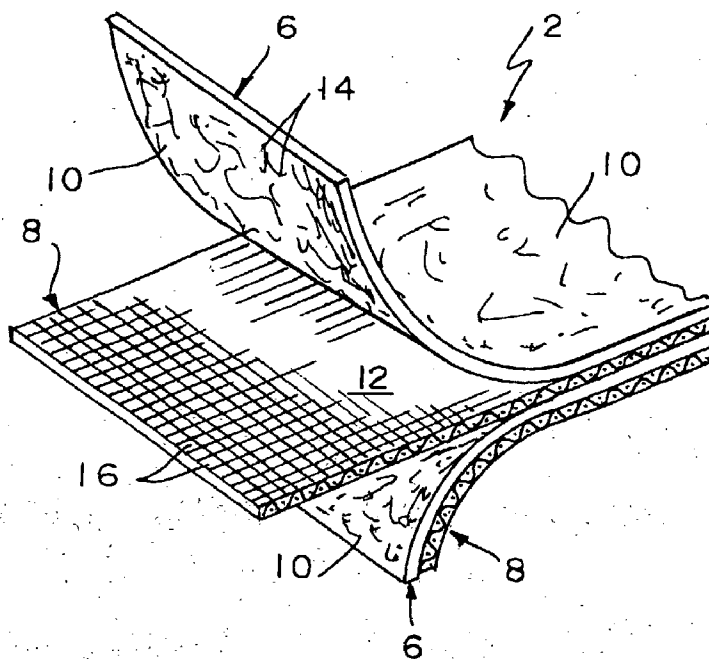
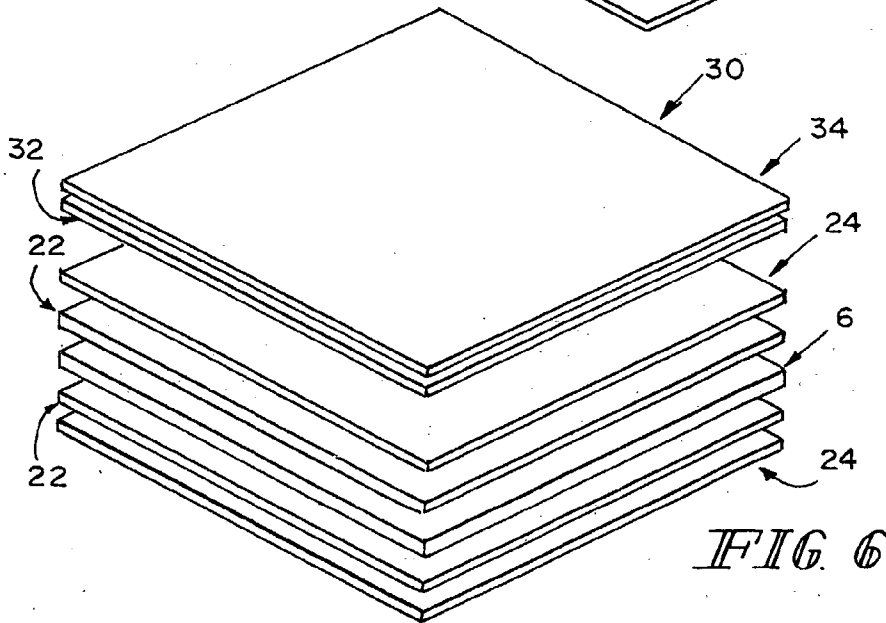
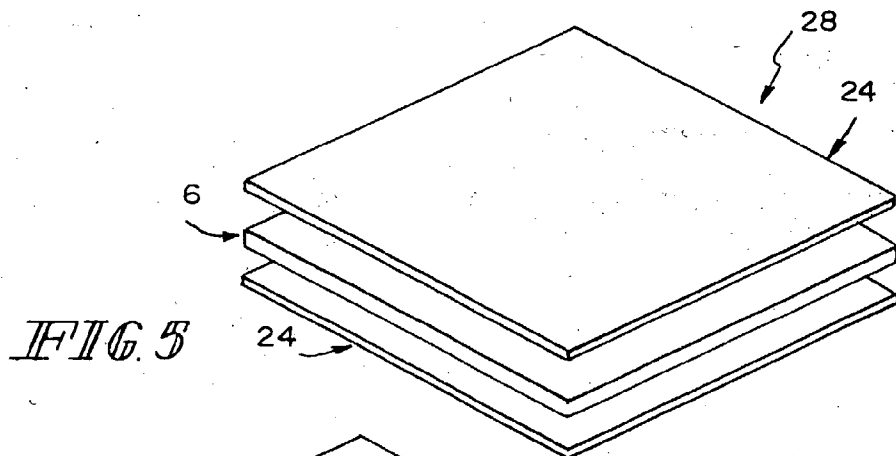
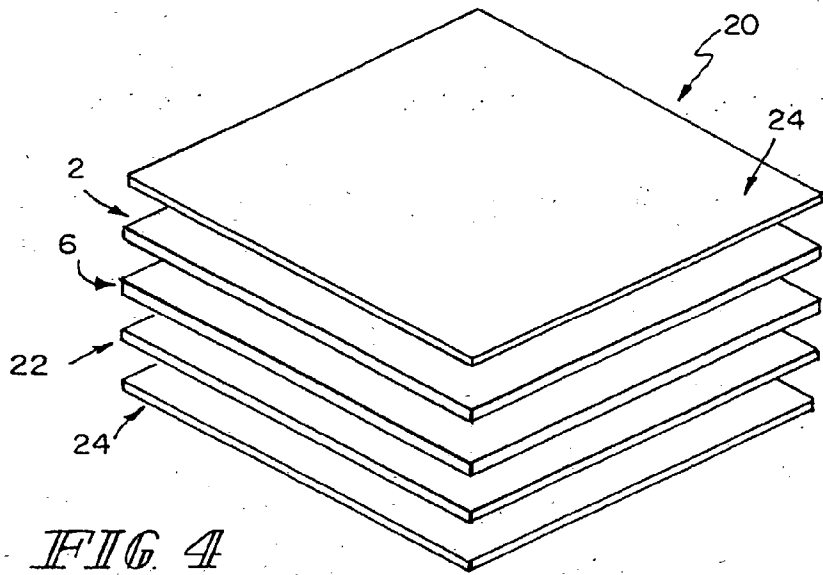

FIG. 3



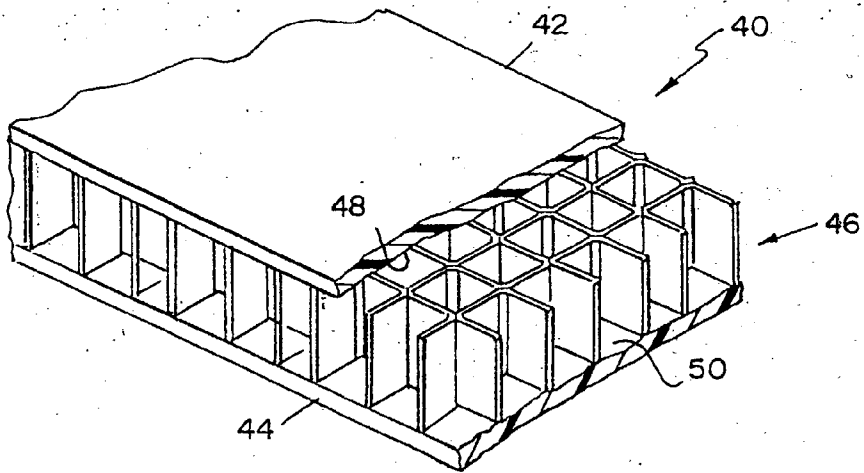

FIG. 7

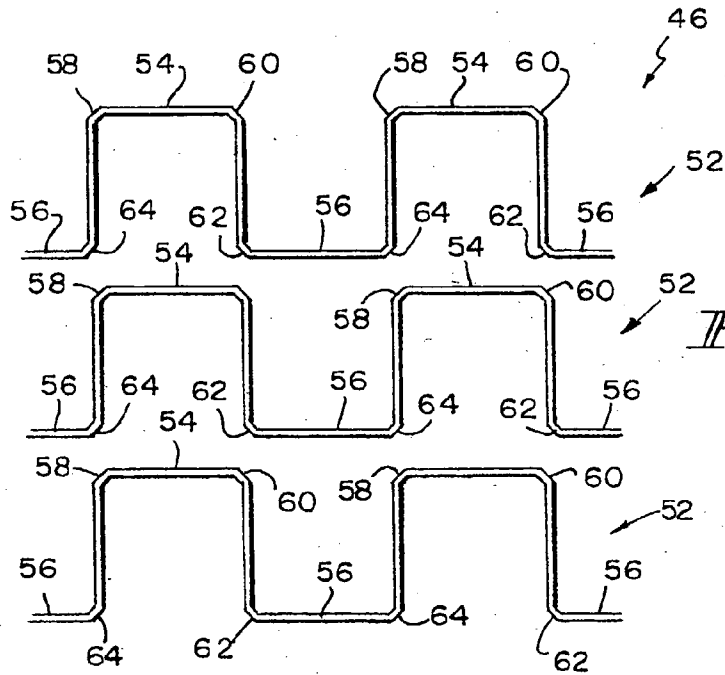

FIG. 8

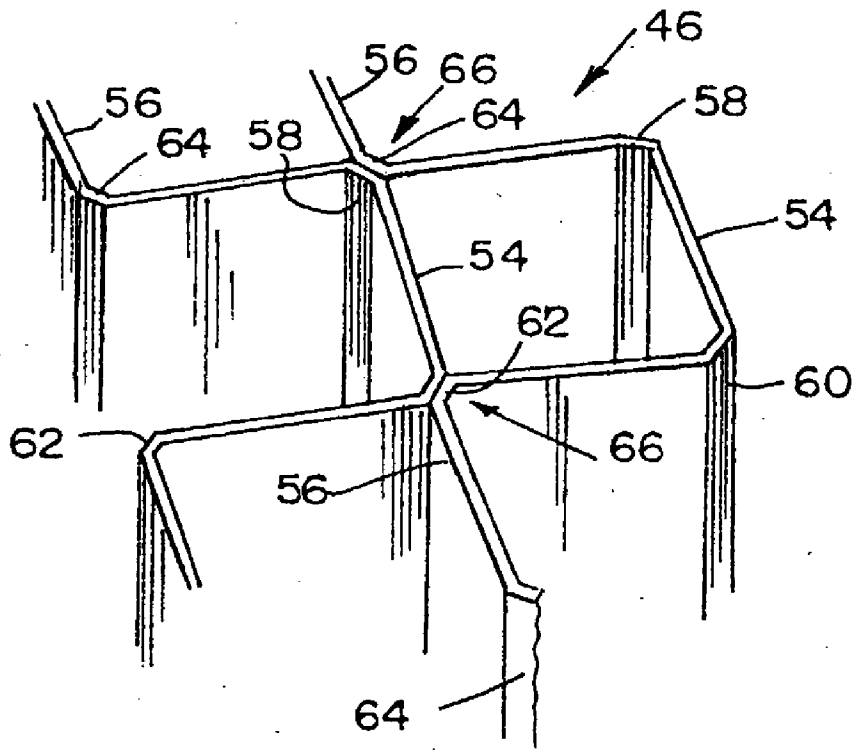

FIG. 9

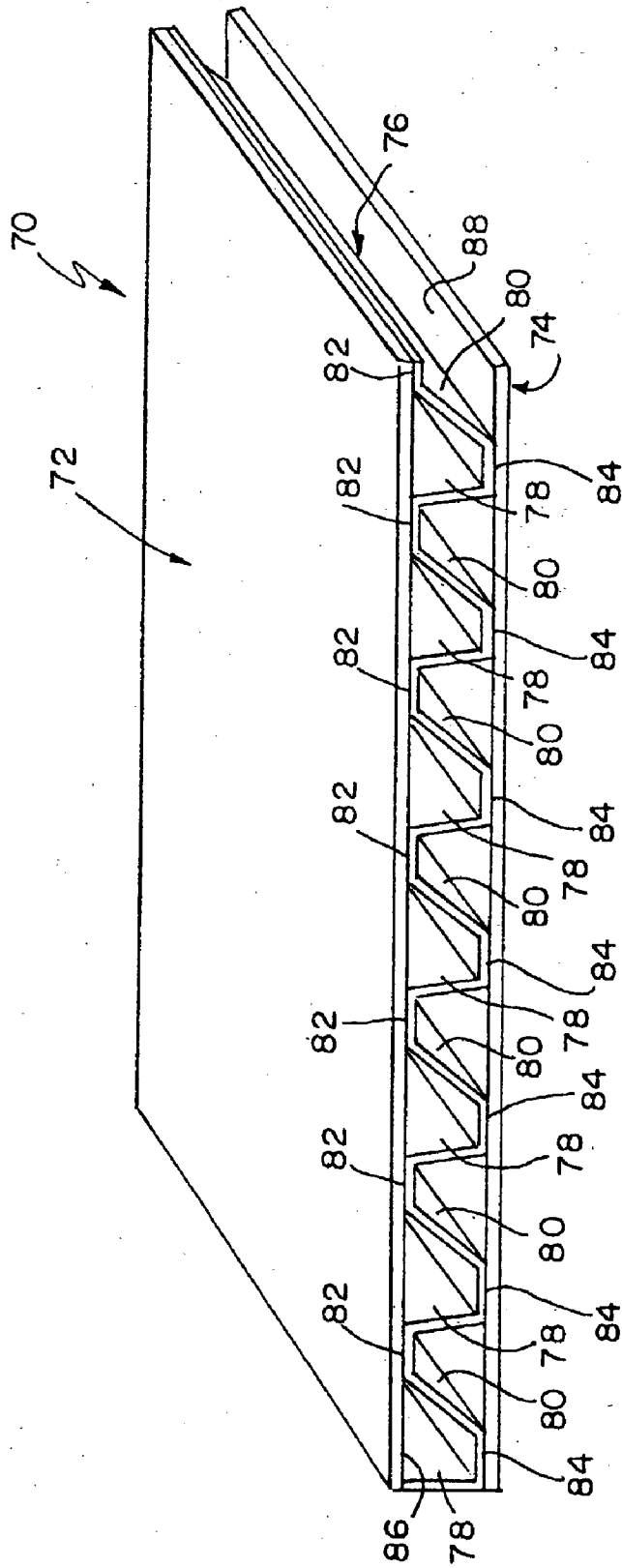

FIG 10

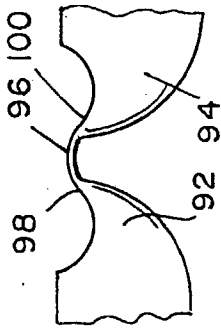

FIG. 11b

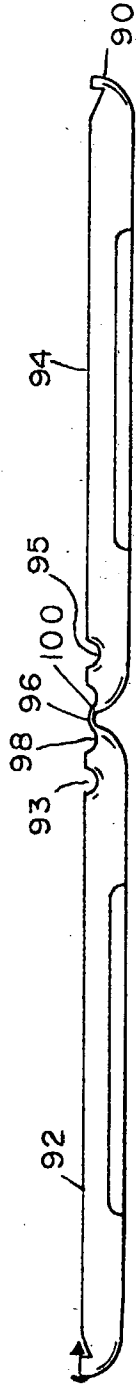

FIG. 11a

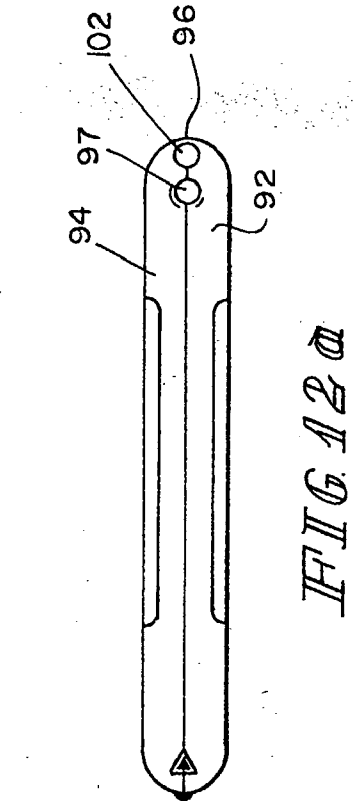

FIG. 12a

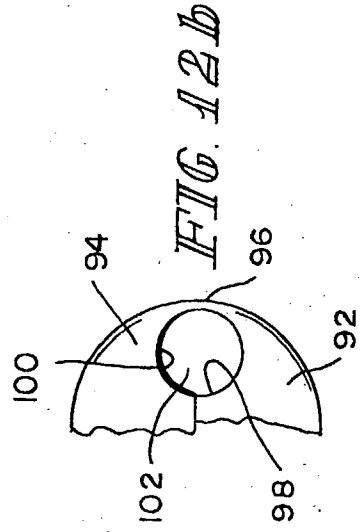

FIG. 12b

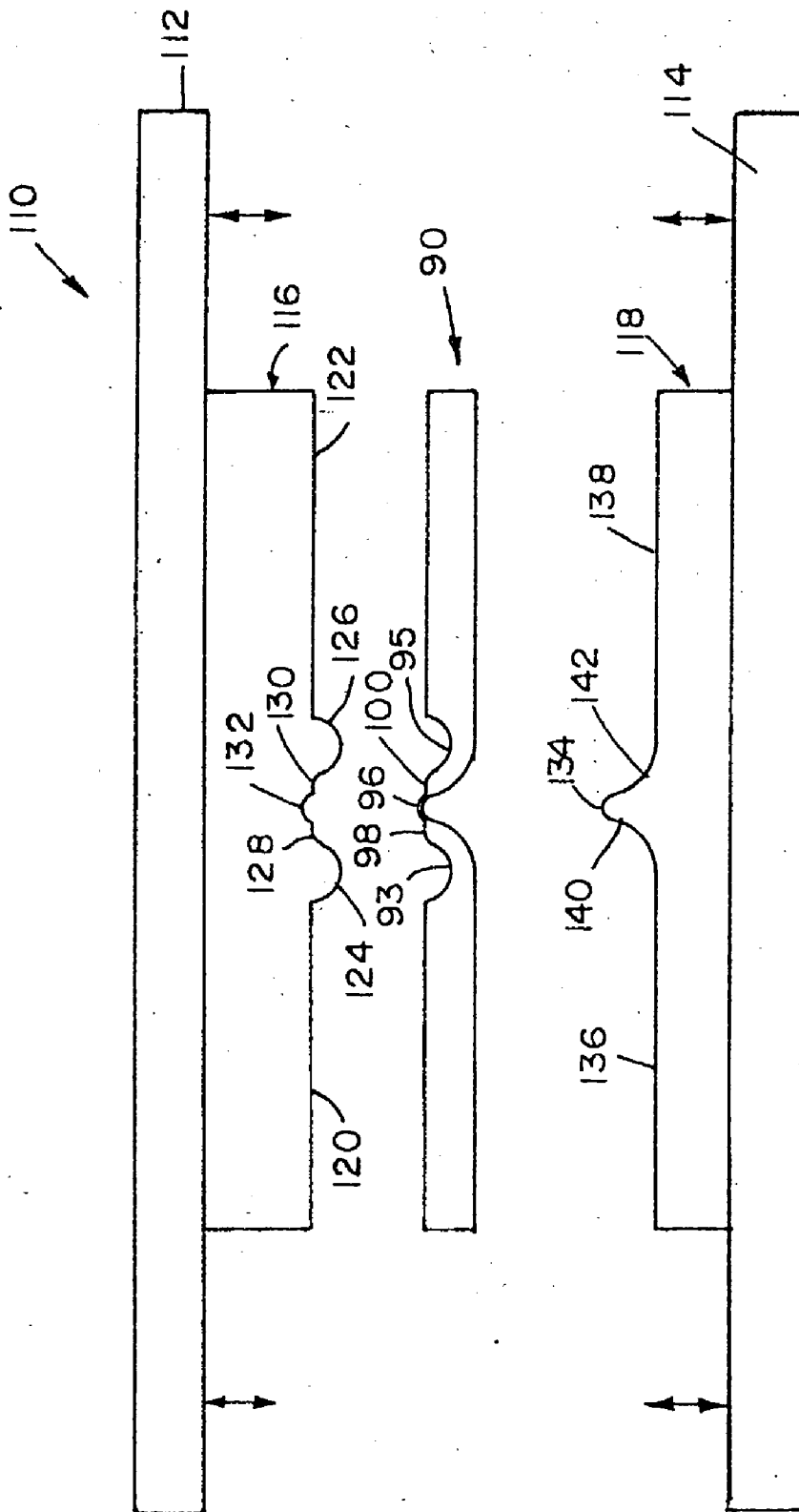

FIG. 13

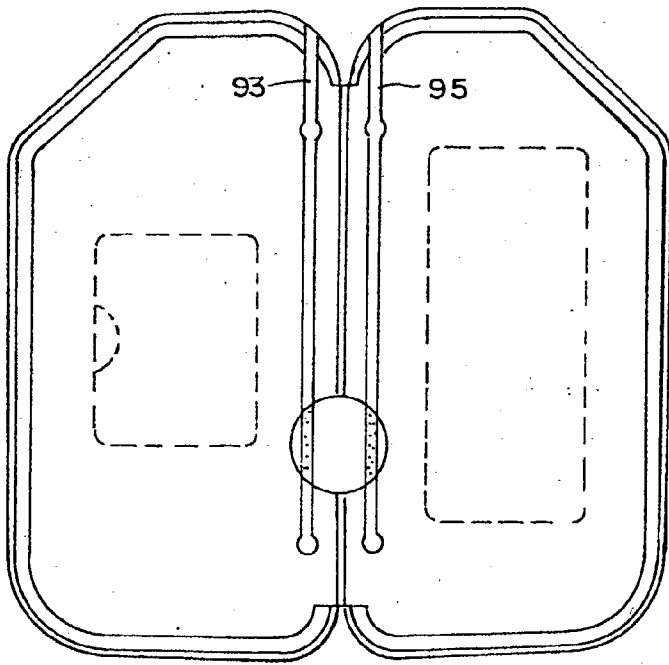

FIG. 14a

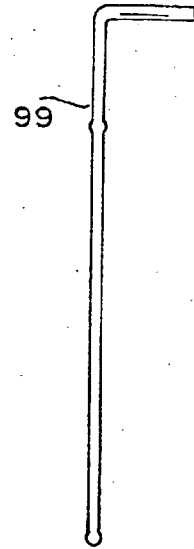

FIG. 14b

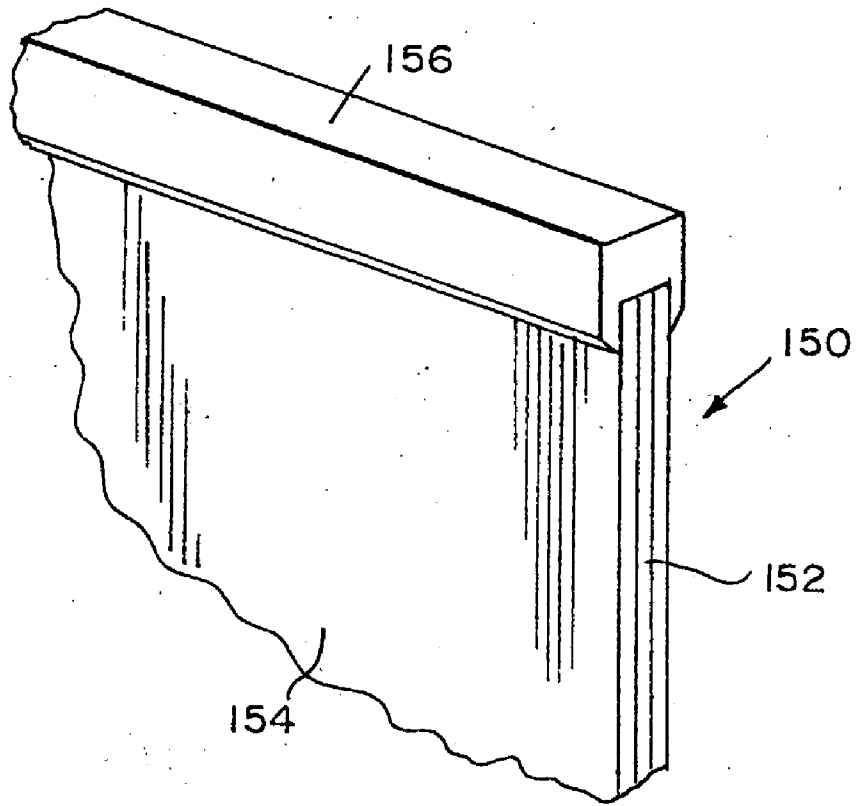

FIG. 15

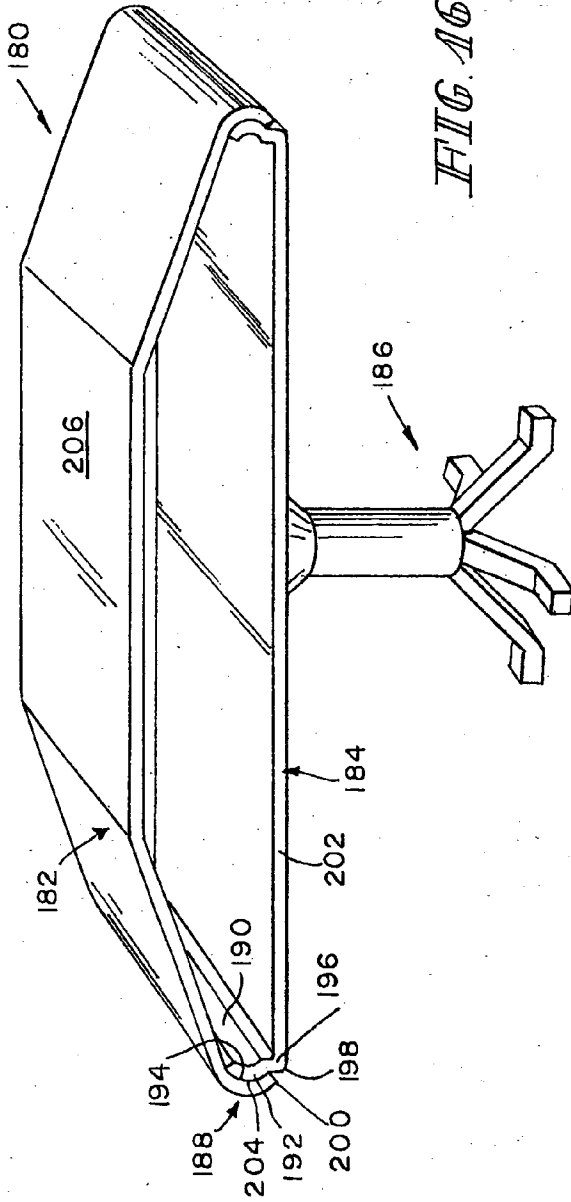

FIG. 16

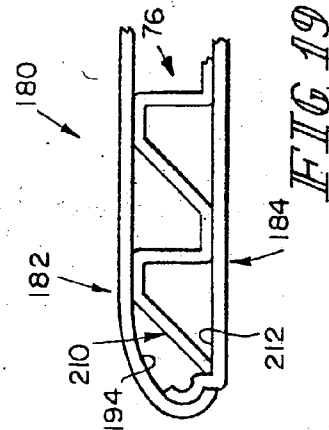

FIG. 19

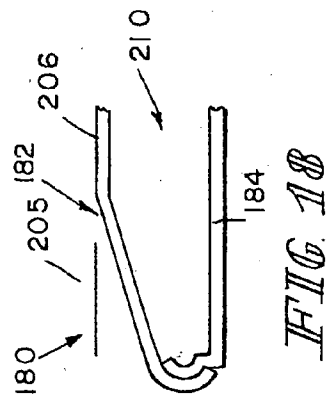

FIG. 18

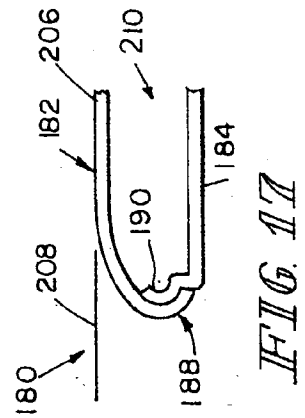

FIG. 17

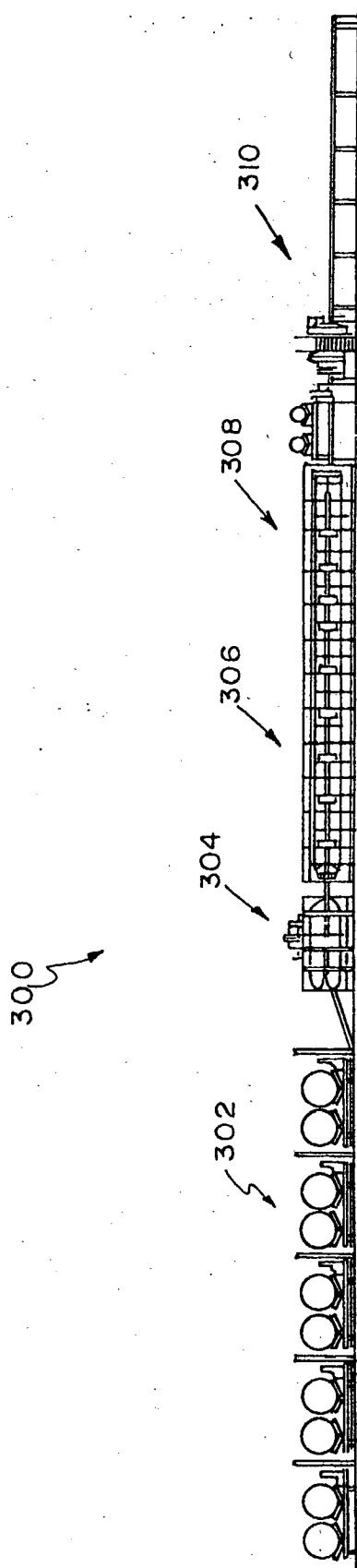

FIG. 20

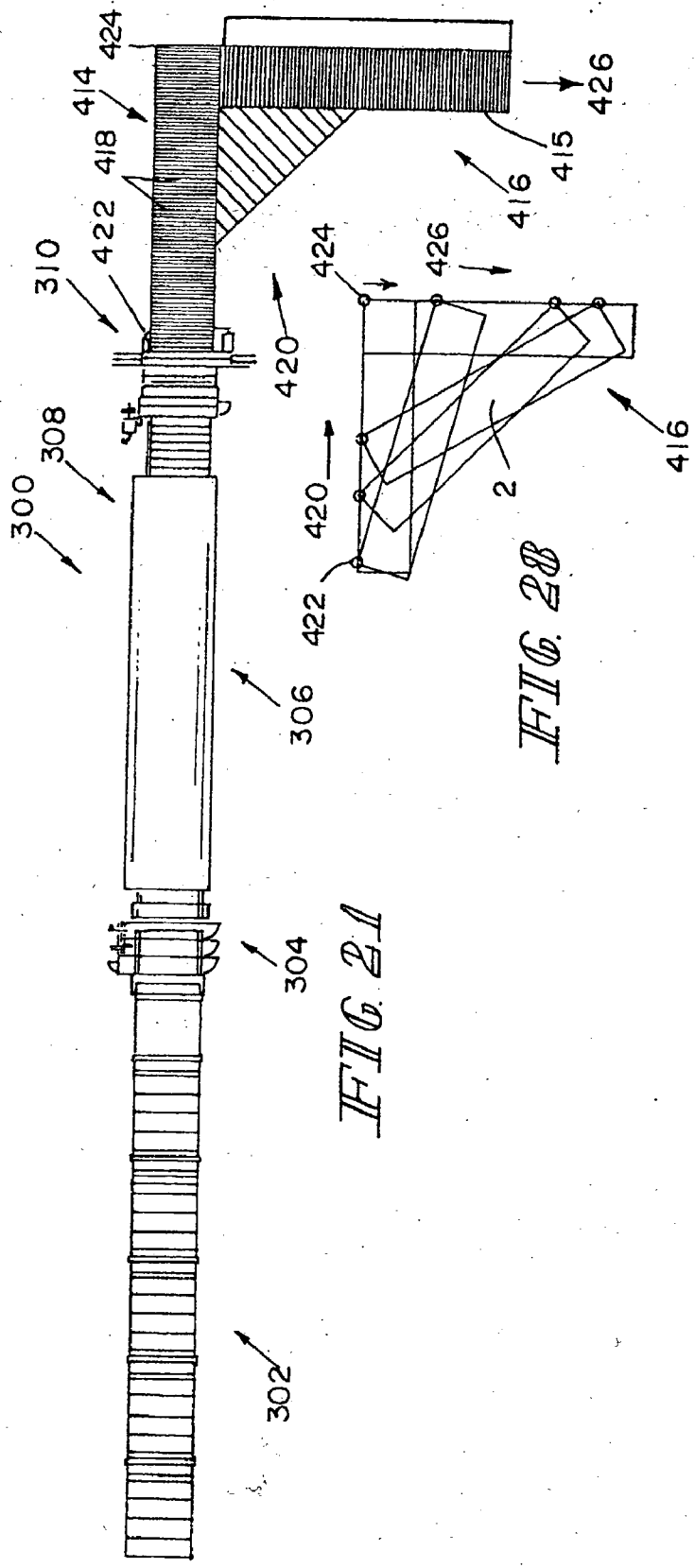

FIG. 21

FIG. 2B

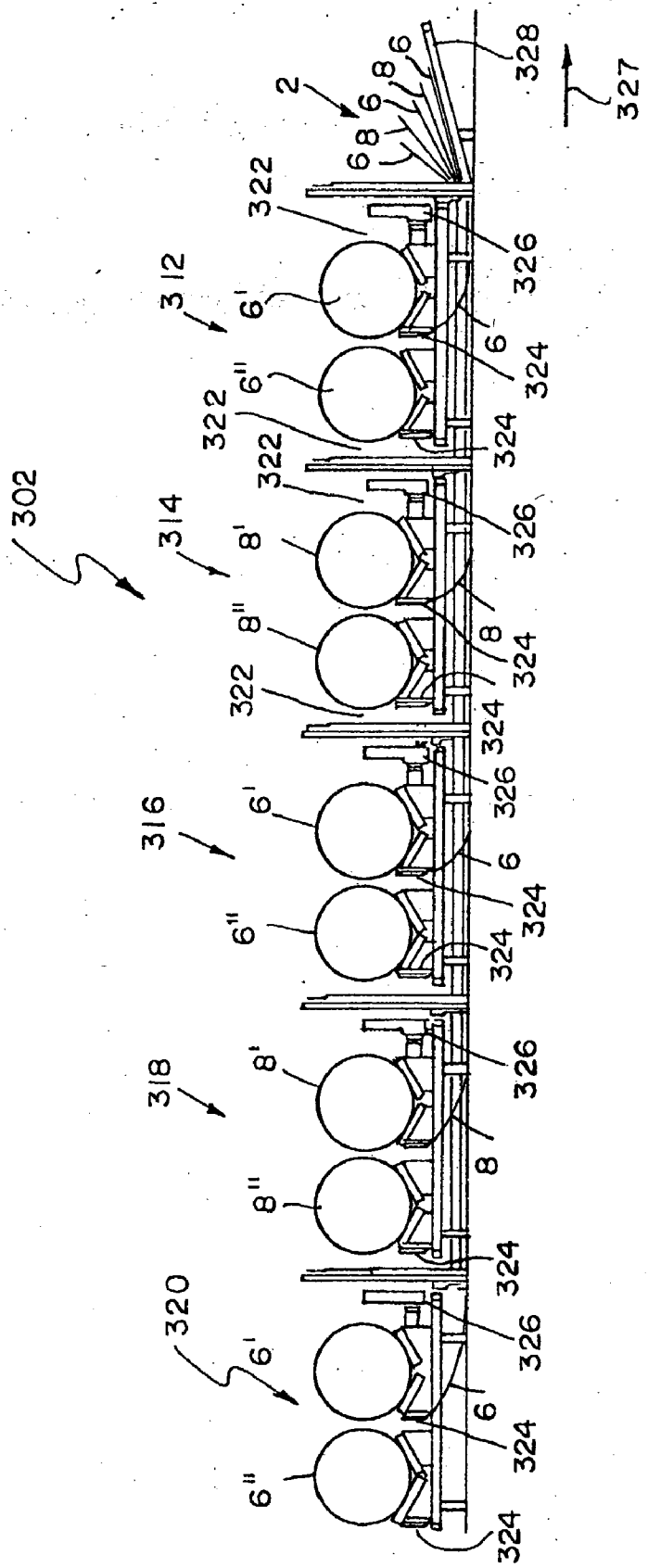

FIG. 22

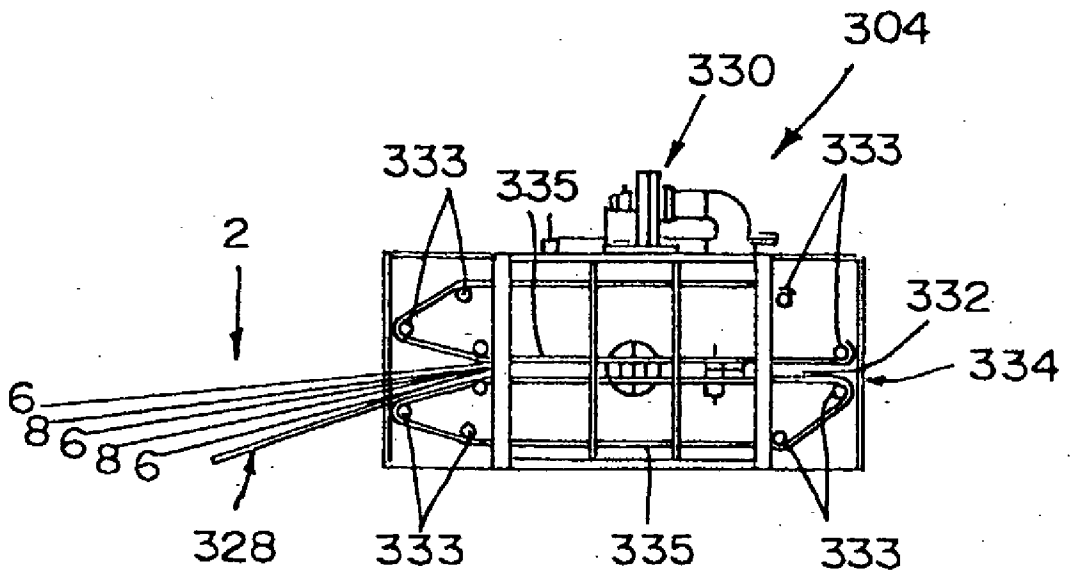

FIG. 23

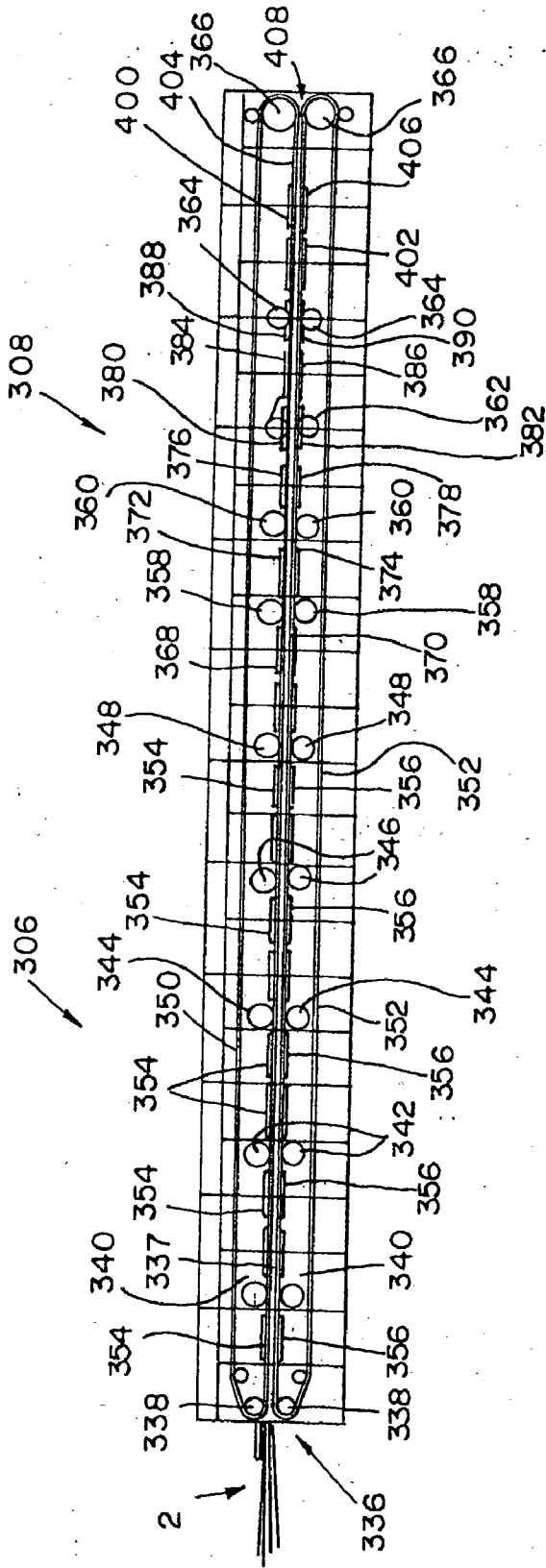

FIG. 24

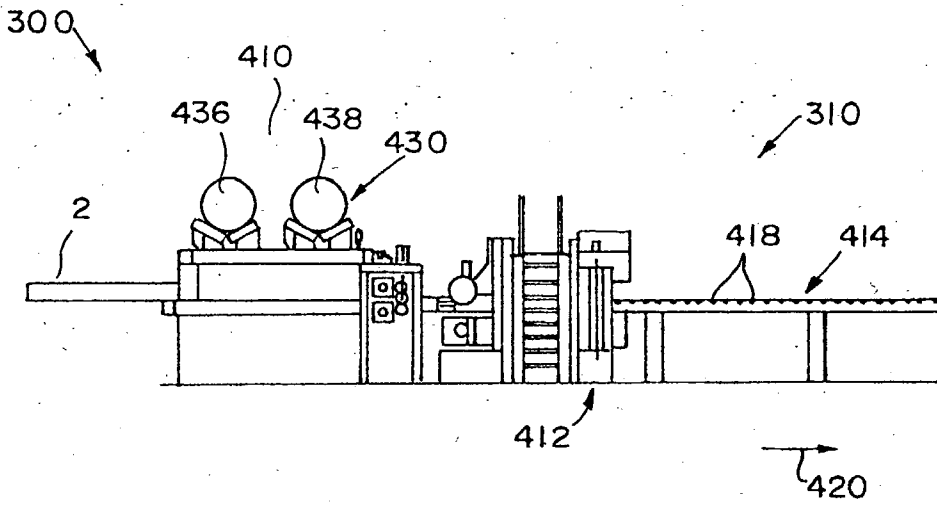

FIG 25

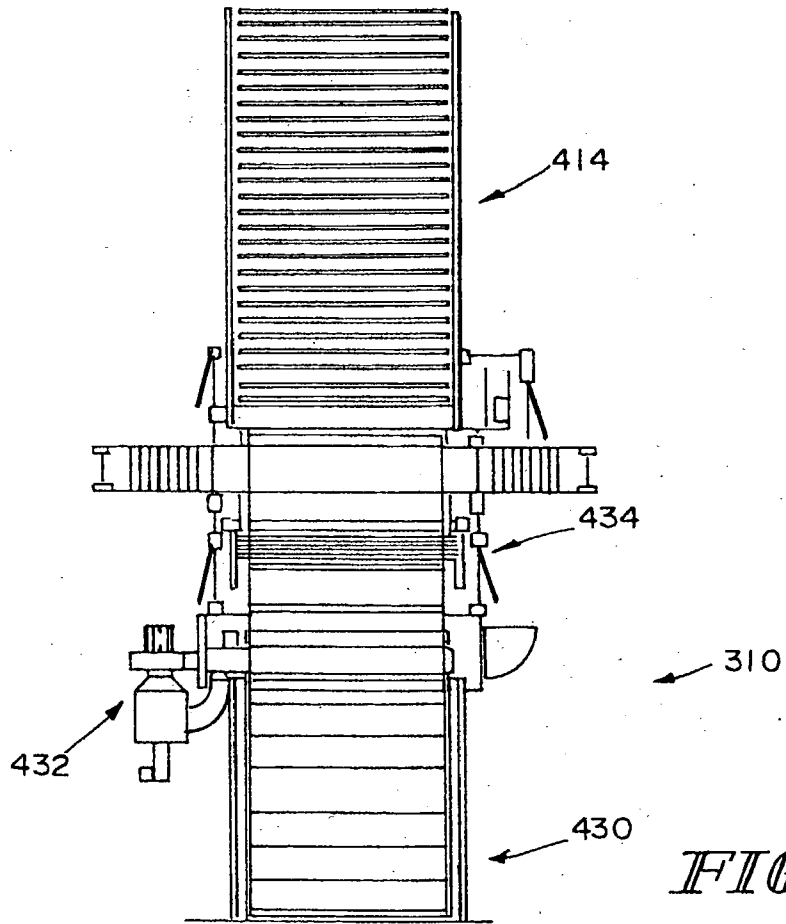

FIG 26

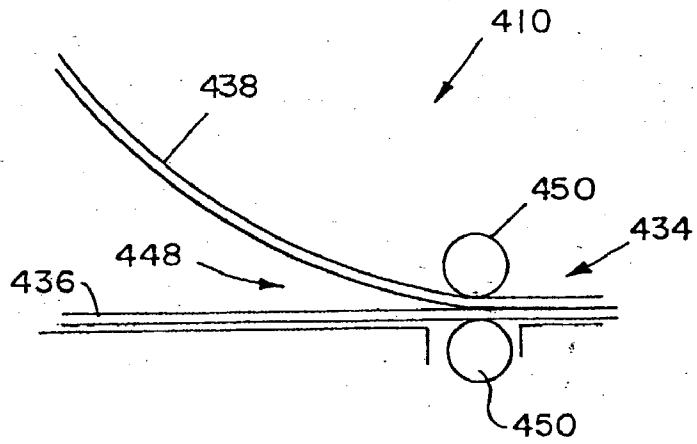

FIG. 27

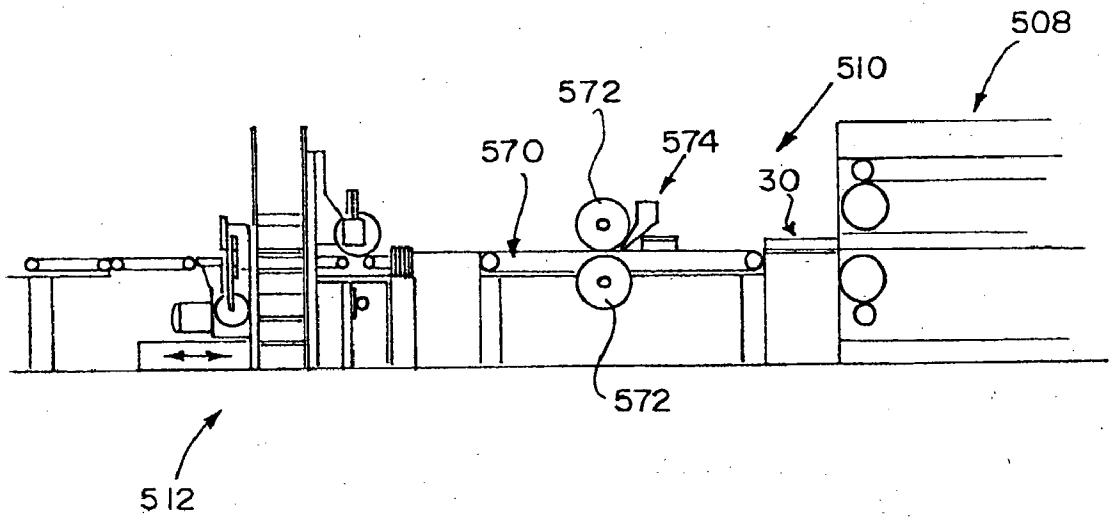
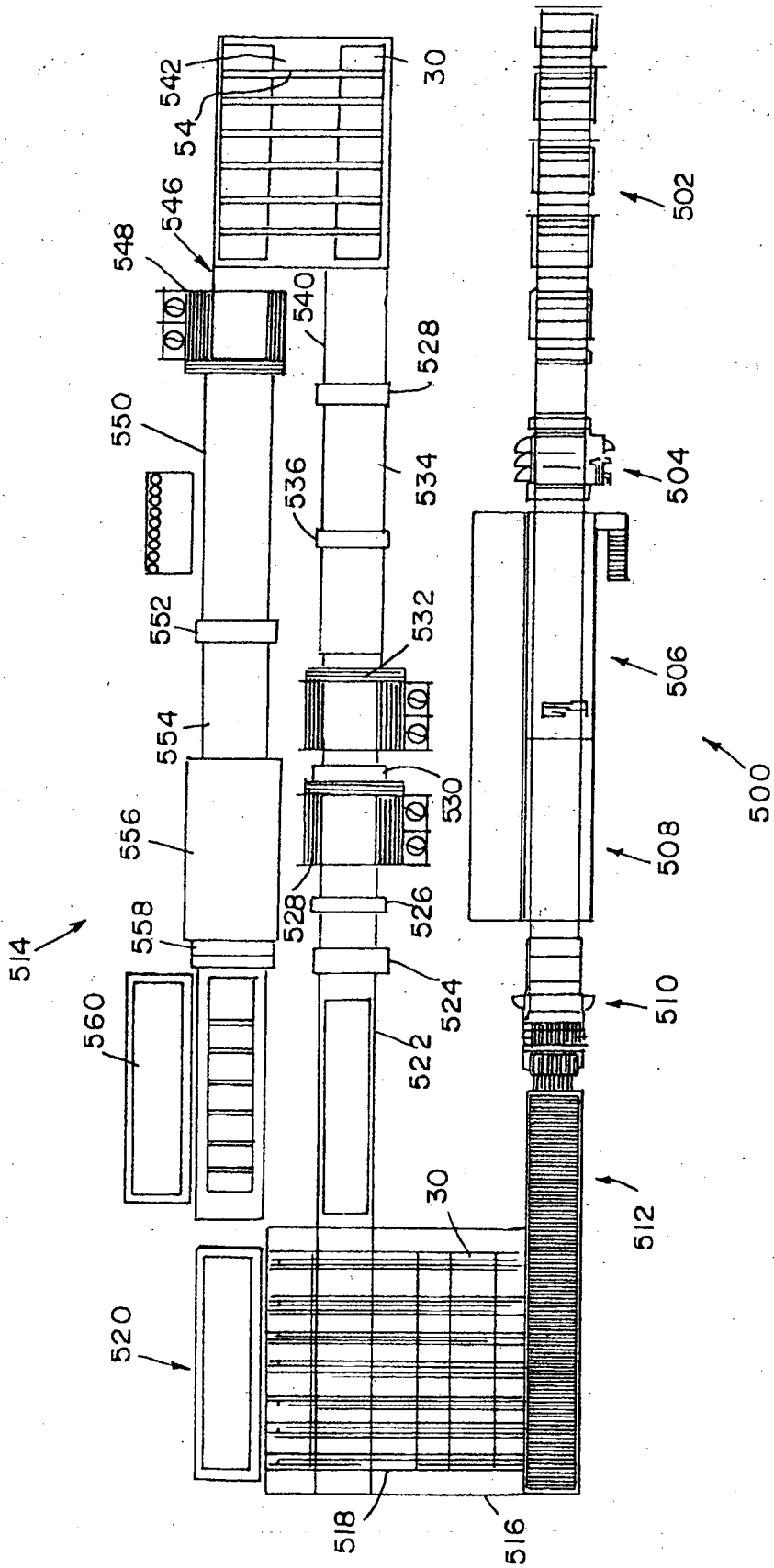

FIG. 30

FIG. 29



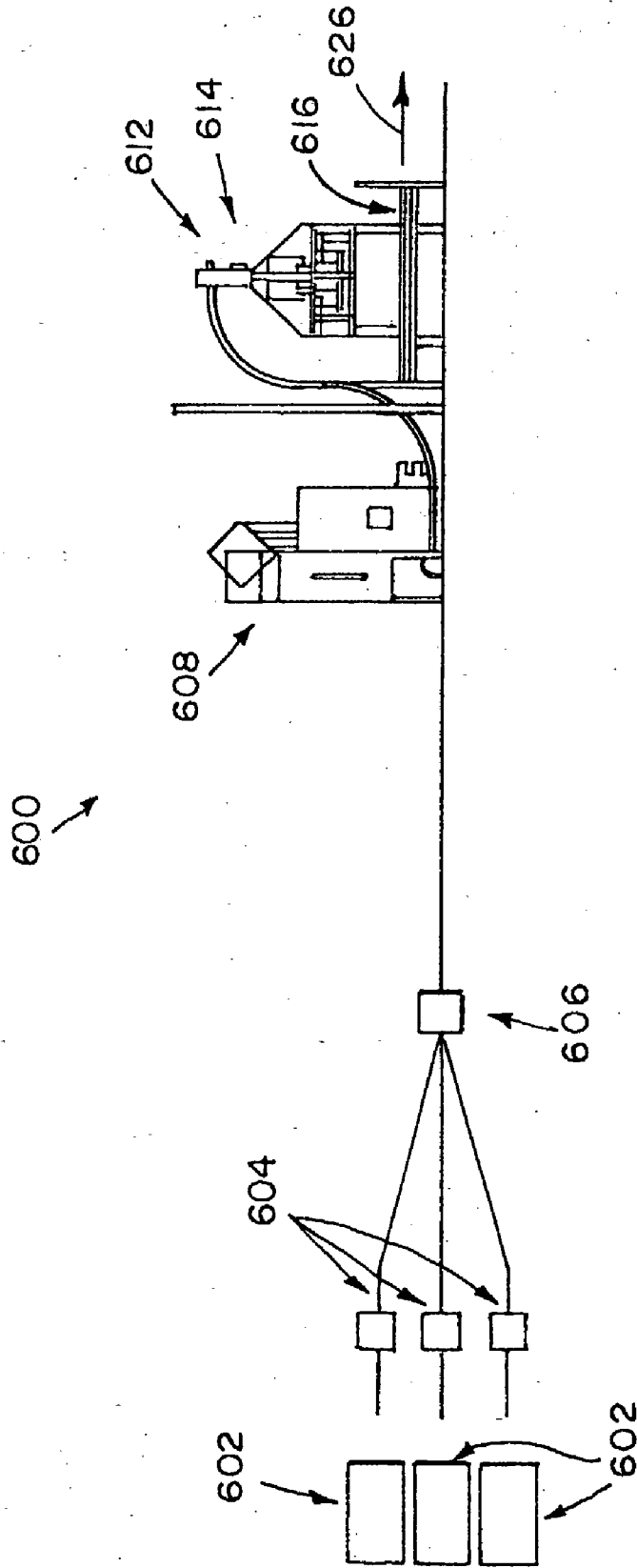

FIG. 31

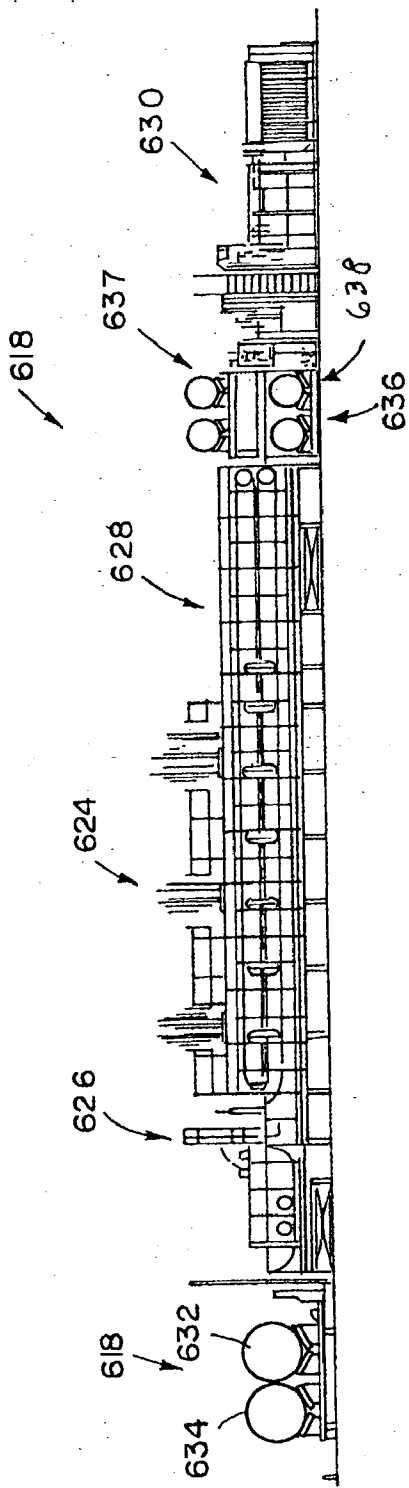

FIG. 32

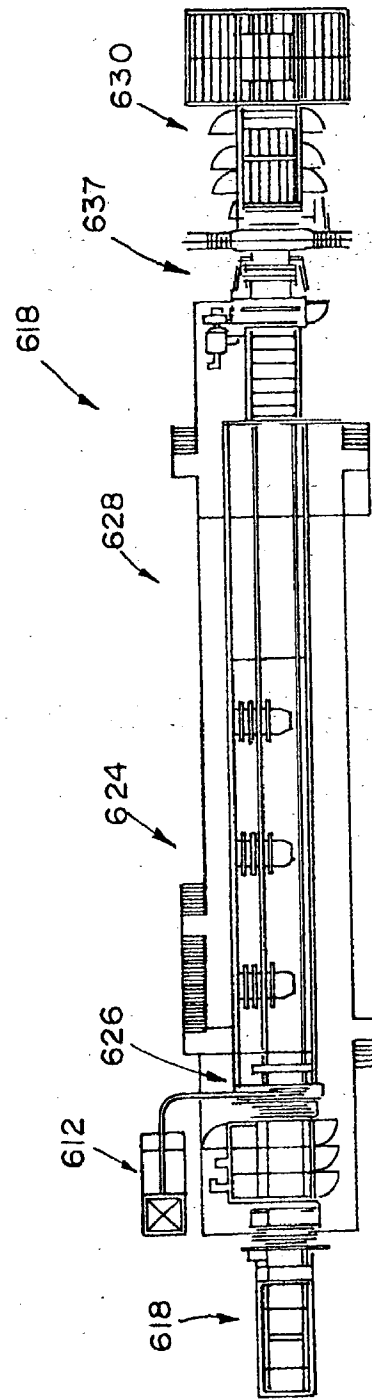

FIG. 33

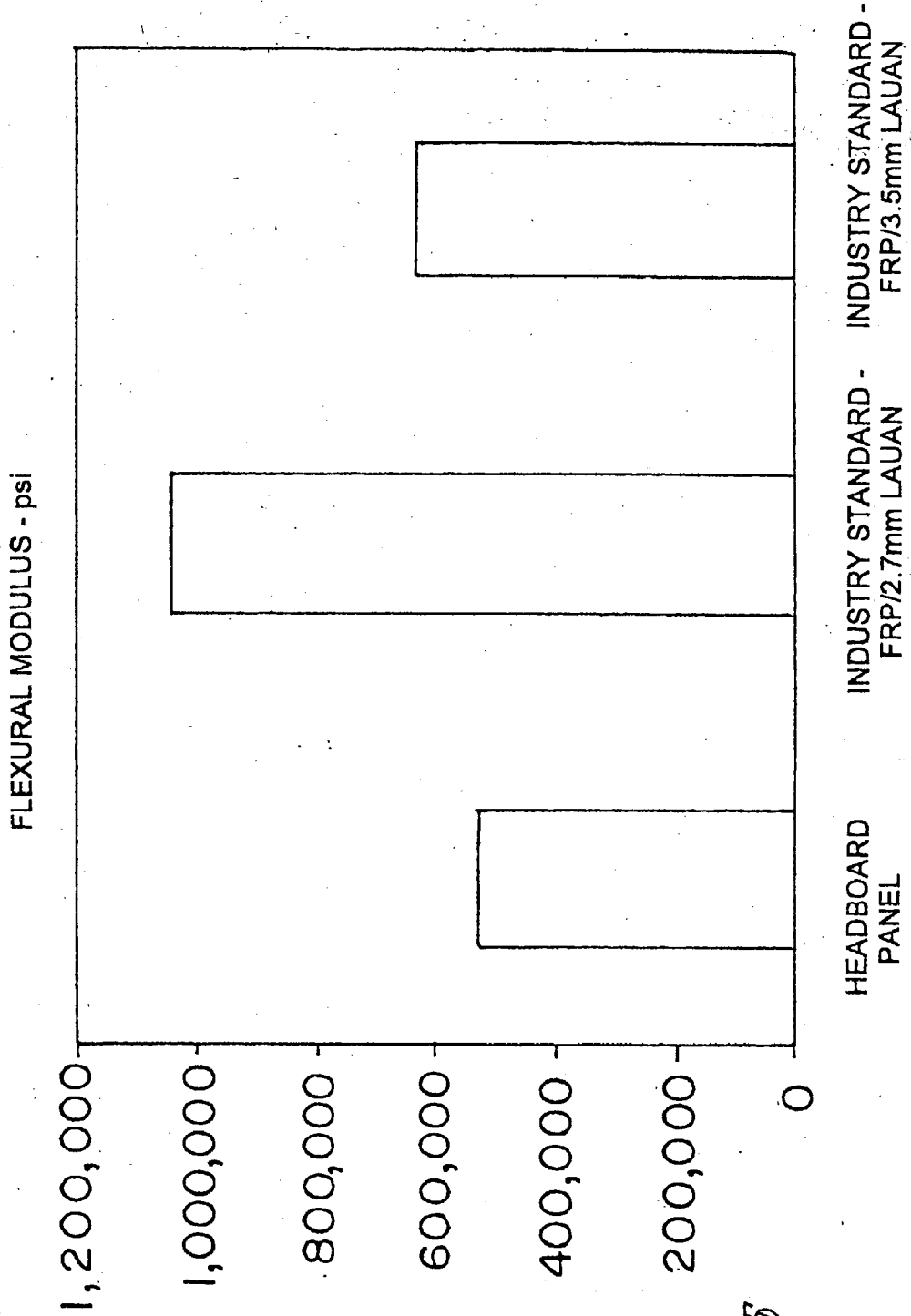
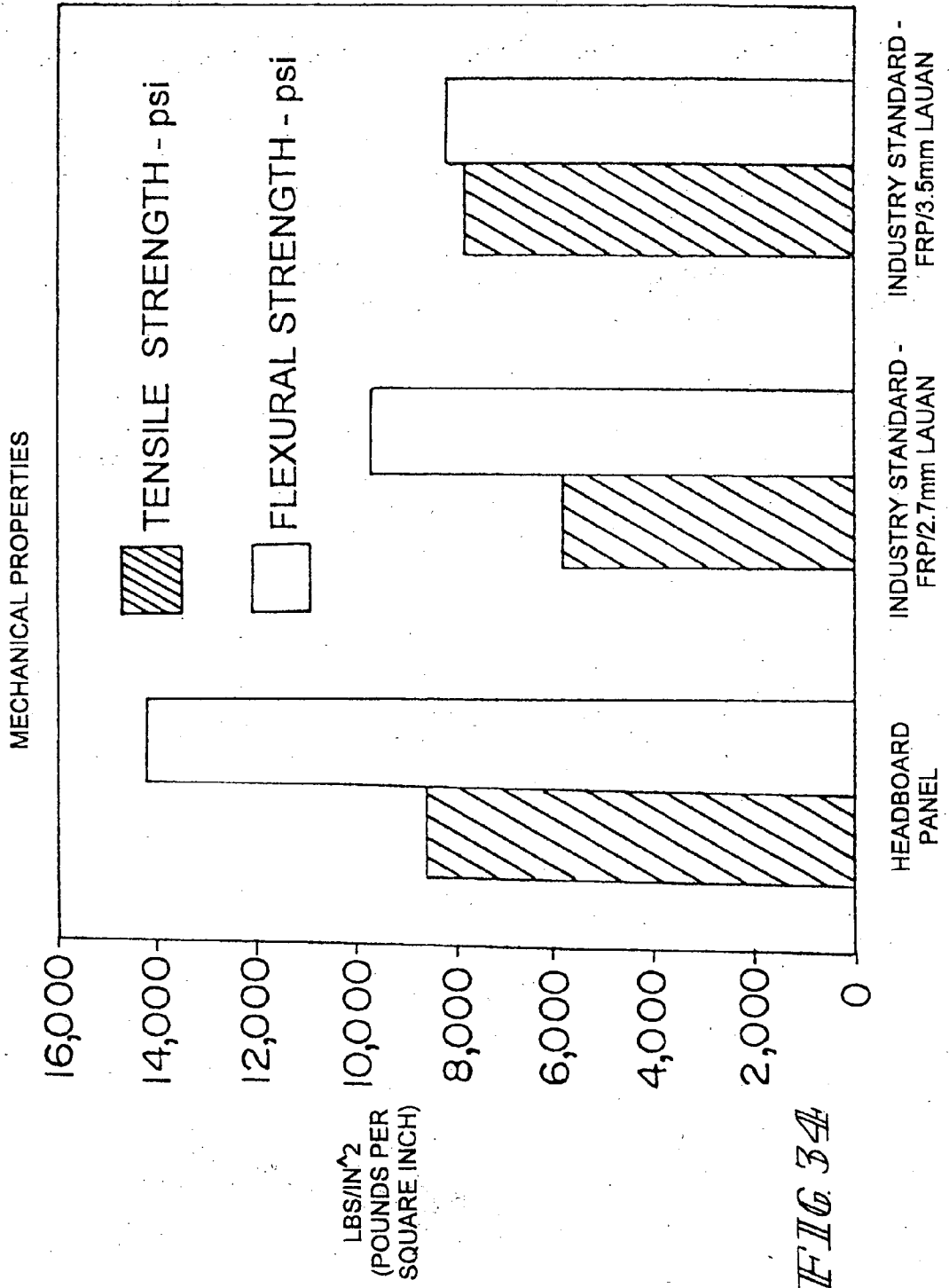

FIG. 35



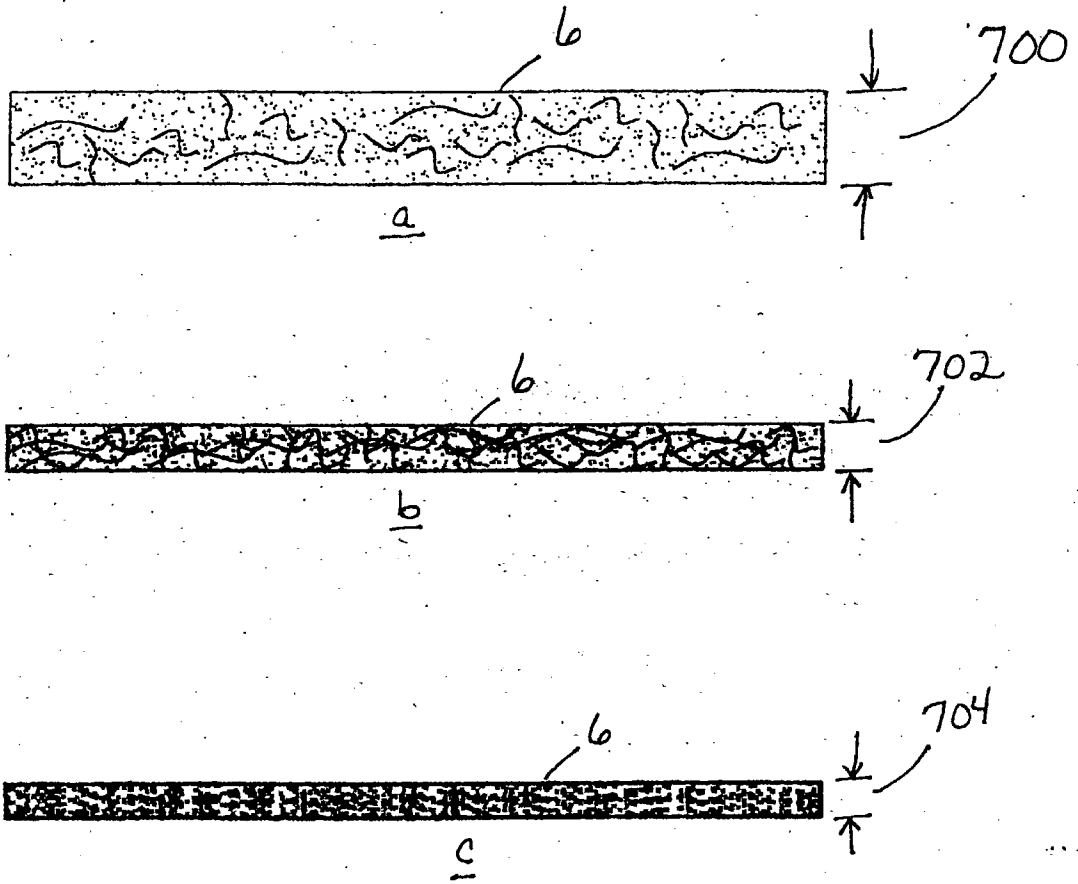

Fig. 36

PROCESS, COMPOSITION AND COATING OF LAMINATE MATERIAL

RELATED APPLICATIONS

[0001] The present application is also a Continuation-in-Part of U.S. patent application Ser. No. 10/287,250, filed on Nov. 4, 2002, which is related to and claims priority to the following U.S. Provisional Patent Applications: Serial No. 60/347,858, filed on Nov. 7, 2001, entitled Laminated Panels and Processes; Serial No. 60/349,541, filed on Jan. 18, 2002, entitled Truss Panel; Serial No. 60/358,857, filed on Feb. 22, 2002, entitled Compression Molded Visor; Serial No. 60/359,017, filed on Feb. 22, 2002, entitled Assemblies and Tooling for Work Surfaces; Serial No. 60/359,602, filed on Feb. 26, 2002, entitled Compression Molded Visor, and Serial No. 60/400,173, filed on Jul. 31, 2002, entitled Composite Material. To the extent not included below, the subject matter disclosed in these applications is hereby expressly incorporated into the present application.

TECHNICAL FIELD

[0002] The present disclosure relates to fiber boards panels, and more particularly fiber board laminated composites, uses and structures, and processes of making the same.

BACKGROUND AND SUMMARY

[0003] Industry is consistently moving away from wood and metal structural members and panels, particularly in the vehicle manufacturing industry. Such wood and metal structural members and panels have high weight to strength ratios. In other words, the higher the strength of the wood and metal structural members and panels, the higher the weight. The resulting demand for alternative material structural members and panels has, thus, risen proportionately. Because of their low weight to strength ratios, as well as their corrosion resistance, such non-metallic panels have become particularly useful as structural members in the vehicle manufacturing industry as well as office structures industry, for example.

[0004] Often such non-metallic materials are in the form of composite structures or panels which are moldable into three-dimensional shapes for use in any variety of purposes. It would, thus, be beneficial to provide a composite material structure that has high strength using oriented and/or non-oriented fibers with bonding agents having compatible chemistries to provide a strong bond across the composite's layers. It would be further beneficial to provide a manufacturing and finish coating process for such structures in some embodiments.

[0005] It will be appreciated that the prior art includes many types of laminated composite panels and manufacturing processes for the same. U.S. Pat. No. 4,539,253, filed on Mar. 30, 1984, entitled High Impact Strength Fiber Resin Matrix Composites, U.S. Pat. No. 5,141,804, filed on May 22, 1990, entitled Interleaf Layer Fiber Reinforced Resin Laminate Composites, U.S. Pat. No. 6,180,206 B1, filed on Sep. 14, 1998, entitled Composite Honeycomb Sandwich Panel for Fixed Leading Edges, U.S. Pat. No. 5,708,925, filed on May 10, 1996, entitled Multi-Layered Panel Having a Core Including Natural Fibers and Method of Producing the Same, U.S. Pat. No. 4,353,947, filed Oct. 5, 1981, entitled Laminated Composite Structure and Method of

Manufacture, U.S. Pat. No. 5,258,087, filed on Mar. 13, 1992, entitled Method of Making a Composite Structure, U.S. Pat. No. 5,503,903, filed on Sep. 16, 1993, entitled Automotive Headliner Panel and Method of Making Same, U.S. Pat. No. 5,141,583, filed on Nov. 14, 1991, entitled Method of and Apparatus for Continuously Fabricating Laminates, U.S. Pat. No. 4,466,847, filed on May 6, 1983, entitled Method for the Continuous Production of Laminates, and U.S. Pat. No. 5,486,256, filed on May 17, 1994, entitled Method of Making a Headliner and the Like, are all incorporated herein by reference to establish the nature and characteristics of such laminated composite panels and manufacturing processes herein.

[0006] Accordingly, the following disclosure provides a fibrous moldable substrate comprising a mat. The mat comprises a fibrous material and a binder. The fibers of the fibrous material are randomly oriented. The fibrous material and binder is subjected to heat such that only a portion of the binder is wetted to the fibrous material.

[0007] Illustrative embodiments may provide the fibrous material being hemp and/or kenaf; the fibrous material being about 50 weight percent hemp and 50 weight percent kenaf; the mat being about 25 weight percent hemp, about 25 weight percent kenaf and about 50 weight percent the binder; the binder being a thermomelt binder; the binder being polypropylene; the mat comprises about 24.75 weight percent hemp, about 24.75 weight percent kenaf, about 50 weight percent a polypropylene binder material and about 0.05 weight percent maleic anhydride; the mat being subjected to a compression force where its cross-section is reduced; the mat experiences insubstantial two-dimensional shrinkage while being subjected to the heat; and the fibrous material being selected from a group comprising hemp, kenaf, flax and jute.

[0008] Another embodiment of the disclosure provides a fibrous moldable substrate also comprising a mat. The mat too comprises a fibrous material and a binder. The fibers of the fibrous material are randomly oriented. The fibrous material and binder is subjected to heat such that only a portion of the binder is wetted to the fibrous material and the binder become dimensionally stable when cooled.

[0009] Illustrative embodiments may provide the fibrous material being hemp and/or kenaf; the fibrous material being about 50 weight percent hemp and 50 weight percent kenaf; the mat being about 25 weight percent hemp, about 25 weight percent kenaf and about 50 weight percent the binder; the binder being a thermomelt binder; the binder being polypropylene; the mat comprises about 24.75 weight percent hemp, about 24.75 weight percent kenaf, about 50 weight percent a polypropylene binder material and about 0.05 weight percent maleic anhydride; the mat being subjected to a compression force where its cross-section is reduced; the mat experiencing insubstantial two-dimensional shrinkage while being subjected to the heat; and the fibrous material is selected from a group comprising hemp, kenaf, flax and jute.

[0010] Another embodiment of the disclosure too provides a fibrous moldable substrate comprising a mat. The mat comprising a fibrous material and a binder, wherein fibers of the fibrous material are randomly oriented, and the fibrous material and binder is subjected to heat such that only a portion of the binder is wetted to the fibrous material; In addition, the mat is semipermeable when cooled.

[0011] Additional features and advantages of this disclosure will become apparent to those skilled in the art upon consideration of the following detailed description of illustrated embodiments exemplifying the best mode of carrying out such embodiments as presently perceived.

BRIEF DESCRIPTION OF DRAWINGS

[0012] The present disclosure will be described hereafter with reference to the attached drawings which are given as non-limiting examples only, in which:

[0013] **FIG. 1** is an exploded side view of a laminated hardboard panel;

[0014] **FIG. 2** is a side view of the laminated hardboard panel of **FIG. 1** in an illustrative-shaped configuration;

[0015] **FIG. 3** is a perspective view of a portion of the laminated hardboard panel of **FIG. 1** showing partially-peeled plies of woven and non-woven material layers;

[0016] **FIG. 4** is another embodiment of a laminated hardboard panel;

[0017] **FIG. 5** is another embodiment of a laminated hardboard panel;

[0018] **FIG. 6** is another embodiment of a laminated hardboard panel;

[0019] **FIG. 7** is a perspective view of a honeycomb core laminated panel;

[0020] **FIG. 8** is a top, exploded view of the honeycomb section of the panel of **FIG. 7**;

[0021] **FIG. 9** is a perspective view of a portion of the honeycomb section of the panel of **FIG. 7**;

[0022] **FIG. 10** is a perspective view of a truss core laminated panel;

[0023] **FIG. 11a** is a side view of an illustrative hinged visor body in the open position;

[0024] **FIG. 11b** is a detail view of the hinge portion of the visor body of **FIG. 11a**;

[0025] **FIG. 12a** is a side view of an illustrative hinged visor body in the folded position;

[0026] **FIG. 12b** is a detail view of the hinge portion of the visor body of **FIG. 12a**;

[0027] **FIG. 13** is an end view of a die assembly to compression mold a fiber material body and hinge;

[0028] **FIG. 14a** is a top view of the visor body of **FIGS. 11 and 12** in the open position;

[0029] **FIG. 14b** is an illustrative visor attachment rod;

[0030] **FIG. 15** is a perspective view of a wall panel comprising a laminated panel body;

[0031] **FIG. 16** is a work body;

[0032] **FIG. 17** is a sectional end view of a portion of the work body of **FIG. 16** showing an illustrative connection between first and second portions;

[0033] **FIG. 18** is a sectional end view of a portion of the work body of **FIG. 16** showing another illustrative connection between first and second portions;

[0034] **FIG. 19** is a sectional end view of a portion of the work body of **FIG. 16** showing another illustrative connection between first and second portions;

[0035] **FIG. 20** is a side view of a hardboard manufacturing line;

[0036] **FIG. 21a** is a top view of the hardboard manufacturing line of **FIG. 20**;

[0037] **FIG. 22** is a side view of the uncoiling and mating stages of the hardboard manufacturing line of **FIG. 20**;

[0038] **FIG. 23** is a side view of the pre-heating stage of the hardboard manufacturing line of **FIG. 20**;

[0039] **FIG. 24** is a side view of the heat, press and cooling stages of the hardboard manufacturing line of **FIG. 20**;

[0040] **FIG. 25** is a side view of a laminating station and shear and trim stages as well as a finishing stage of the hardboard manufacturing line of **FIG. 20**;

[0041] **FIG. 26** is a top view of the laminating station and shear and trim stages as well as the finishing stage of the hardboard manufacturing line of **FIG. 20**;

[0042] **FIG. 27** is a side view of a portion of the laminating station stage of the hardboard manufacturing line of **FIG. 20**;

[0043] **FIG. 28** is another top view of the shear and trim stages as well as the finishing stage of the hardboard manufacturing line of **FIG. 20**;

[0044] **FIG. 29** is a top view of another embodiment of a laminated hardboard manufacturing line;

[0045] **FIG. 30** is a side view of the calendaring stage of the hardboard manufacturing line of **FIG. 29**;

[0046] **FIG. 31** is a diagrammatic and side view of a portion of a materials recycling system;

[0047] **FIG. 32** is a side view of a materials recycling system and laminated hardboard manufacturing line;

[0048] **FIG. 33** is a top view of the materials recycling system and laminated hardboard manufacturing line of **FIGS. 31 and 32**;

[0049] **FIG. 34** is a mechanical properties chart comparing the tensile and flexural strength of an illustrative laminated hardboard panel with industry standards;

[0050] **FIG. 35** is a mechanical properties chart comparing the flexural modulus of an illustrative laminated hardboard panel with industry standards; and

[0051] **FIGS. a through c36** are sectional views of the fibrous material layer subjected to various amounts of heat and pressure.

[0052] Corresponding reference characters indicate corresponding parts throughout the several views. The exemplification set out herein illustrates several embodiments, and such exemplification is not to be construed as limiting the scope of this disclosure in any manner.

DETAILED DESCRIPTION OF THE DRAWINGS

[0053] An exploded side view of a laminated composite hardboard panel **2** is shown in **FIG. 1**. Hardboard panel **2**

illustratively comprises a fascia cover stock **4** positioned as the surface layer of panel **2**. Fascia cover stock **4** may be comprised of fabric, vinyl, leathers, acrylic, epoxies, or polymers, etc. It is appreciated, however, that hardboard panel **2** may include, or not include, such a fascia cover.

[0054] The laminated composite hardboard panel **2** illustratively comprises a first sheet of fibrous material layer **6**. Fibrous material layer **6** illustratively comprises a natural fiber, illustratively about 25 weight percent hemp and about 25 weight percent kenaf with the balance being illustratively polypropylene. The fibers are randomly oriented to provide a nonspecific orientation of strength. Variations of this fibrous material are contemplated including about 24.75 weight percent hemp and about 24.75 weight percent kenaf combination with about 50 weight percent polypropylene and about 0.05 weight percent maleic anhydride. Other such fibrous materials can be used as well, such as flax and jute. It is also contemplated that other blend ratios of the fibrous material can be used to provide a nonspecific orientation of strength. It is further contemplated that other binders in place of polypropylene may also be used for the purpose discussed further herein. Furthermore, it is contemplated that other fibrous materials which have high process temperatures in excess of about 400 degrees F., for example, may be used as well.

[0055] A woven fiber layer **8** illustratively comprises a woven glass with a polypropylene binder, and is illustratively located between the fibrous material layers **6**. It is appreciated that other such woven, non-metal fiber materials may be used in place of glass, including nylon, Kevlar, fleece and other natural or synthetic fibers. Such woven fiber provides bi-directional strength. In contrast, the fibrous material layers **6** provide nonspecific-directional strength, thus giving the resulting composite enhanced multi-directional strength.

[0056] Each surface **10** of fibrous material layers **6** that is adjacent to woven material layer **8** bonds to surfaces **12** of layer **8**. A bond is created between fibrous material layer **6** and woven material layer **8** by a high temperature melt and pressure process as discussed further herein. Because the glass and fibrous layers have compatible binders (i.e., the polypropylene, or comparable binder), layers **6**, **8** will melt and bind, forming an amalgamated bond between the same. Layers **6**, **8** having polypropylene as a common chain in each of their respective chemistries makes the layers compatible and amenable to such three-dimensional molding, for example.

[0057] It is appreciated that panel **2** may comprise a plurality of fibrous material layers **6**, with woven material layers **8** laminated between each pair of adjacent surfaces **10** and **12**, respectively. A pealed view of hardboard panel **2**, shown in FIG. 3, illustrates such combined use of woven and nonspecific-directional or randomly-oriented fibers. The random fibers **14** make up fibrous material layer **6**, whereas the woven fibers **16** make up the fiber layer **8**. Because bulk mass can increase the strength of the panel, it is contemplated that more alternating fibrous and woven fiber layers used in the laminated composite will increase the strength of the panel. The number of layers used, and which layer(s) will be the exterior layer(s), can be varied, and is often dictated by the requirements of the particular application. Testing was conducted on illustrative hardboard panels to

demonstrate tensile and flexural strength. The hardboard laminated material consisted of a first layer of 600 gram 80 percent polypropylene 20 percent polyester fleece, a second layer of 650 gram fiberglass mix (75 percent 0.75 K glass/25 percent polypropylene and 10 percent maleic anhydride), a third layer 1800 gram 25 percent hemp/25 percent kenaf with 5 percent maleic anhydride and the balance polypropylene, a fourth layer of the 650 g fiberglass mix, and a fifth layer of the 600 g 80 percent polypropylene 20 percent polyester fleece. This resulted in an approximate 4300 gram total weight hardboard panel.

[0058] The final panel was formed by subjecting it to a 392 degrees F. oven with a 6 millimeter gap and heated for about 400 seconds. The material was then pressed using a 4.0 millimeter gap. The final composite panel resulted in an approximate final thickness of 4.30 millimeter.

[0059] To determine such panel's tensile and flexural properties, ASTM D 638-00 and ASTM D790-00 were used as guidelines. The panel samples' shape and size conformed to the specification outlined in the standards as closely as possible, but that the sample thickness varied slightly, as noted above. A Tinius Olson Universal testing machine using industry specific fixtures was used to carry out the tests.

[0060] Two lauan boards were coated with a gelcoat finish and formed into final 2.7 millimeter and 3.5 millimeter thickness boards, respectively. These boards were used as a baseline for comparison with the hardboard panel of the present disclosure. Each of the samples were then cut to the shape and sizes pursuant the above standards. The tensile and flexural properties of the lauan boards were determined in the same manner as the hardboard panel above. Once the results were obtained they were then charted against the results of the hardboard panel for comparison, as shown below and in FIGS. 34 and 35. The results herein represent the average over 10 tested samples of each board.

Panel Description	Avg. Tensile Strength - psi	Avg. Flexural Strength - psi	Avg. Flexural Modulus - psi
Hardboard panel	8,585	14,228	524,500
Industry standard - FRP/2.7 mm lauan	5,883	9,680	1,045,700
Industry standard - FRP/3.5 mm lauan	7,900	8,260	624,800

[0061] As depicted by FIG. 2, laminated panel **2** can be formed into any desired shape by methods known to those skilled in the art. It is appreciated that the three-dimensional molding characteristics of several fibrous sheets in combination with the structural support and strength characteristics of glass/polypropylene weave materials located between pairs of the fibrous sheets will produce a laminated composite material that is highly three-dimensionally moldable while maintaining high tensile and flexural strengths. Such a laminated panel is useful for the molding of structural wall panel systems, structural automotive parts, highway trailer side wall panels (exterior and interior), recreational vehicle side wall panels (exterior and interior), automotive and building construction load floors, roof systems, modular constructed wall systems, and other such moldable parts. Such a panel may replace styrene-based chemical set poly-

mers, metal, tree cut lumber, and other similar materials. It is believed that such a moldable laminated panel can reduce part cost, improve air quality with reduced use of styrene, and reduce part weight. Such a panel may also be recyclable, thereby giving the material a presence of sustainability.

[0062] Another embodiment of a hardboard panel **20** is shown in **FIG. 4**. This panel **20** comprises a fibrous material layer **6** serving as the core, and is bounded by fiberglass layers **22** and fleece layers **24**, as shown. For example, the fibrous material layer **6** may comprise the conventional non-oriented fiber/polypropylene mix as previously discussed, at illustratively 1800 or 2400 g weights. The fiberglass layer comprises a 50 weight percent polypropylene/about 50 weight percent maleic anhydride (illustratively 400 g/m²) mix. The fleece layer comprises an about 50 weight percent material provides good adhesion with the polypropylene and is water-proof at ambient conditions. Furthermore, the polyester is a compatible partner with the polypropylene because it has a higher melt temperature than the polypropylene. This means the polypropylene can melt and bond with the other layer without adversely affecting the polyester. In addition, the maleic anhydride is an effective stiffening agent having high tensile and flexural strength which increases overall strength of the panel.

[0063] It is contemplated that the scope of the invention herein is not limited only to the aforementioned quantities, weights and ratio mixes of material and binder. For example, the fleece layer **24** may comprise an about 80 weight percent polypropylene/about 20 weight percent polyester (illustratively 600 g/m²) mix. The laminated composite panel **20** shown in **FIG. 4** may include, for example, both fleece layers **24** comprising the 50/50 polypropylene/polyester mix, or one layer **24** comprising the 50/50 polypropylene/polyester mix, or the 80/20 polypropylene/polyester mix. In addition, same as panel **2**, the binder used for panel **20** can be any suitable binder such as polypropylene, for example.

[0064] Another embodiment of a laminated hardboard panel **28** is shown in **FIG. 5**. This panel **28** comprises a fibrous material layer **6** serving as the core which is bounded by fleece layers **24**, as shown. As with panel **20**, the fibrous material layer **6** of panel **28** may comprise the conventional, non-oriented fiber/polypropylene mix as previously discussed, at illustratively 1800 or 2400 g weights. Each fleece layer **24** may comprise an about 50 weight percent polypropylene/about 50 weight percent polyester (illustratively 300 g/m²) mix, or may alternatively be an about 80 weight percent polypropylene/about 20 weight percent polyester (illustratively 600 g/m²) mix. Or, still alternatively, one fleece layer **24** may be the 50/50 mix and the other fleece layer **24** may be the 80/20 mix, for example.

[0065] Another embodiment of a laminated hardboard panel **30** is shown in **FIG. 6**. This panel **30**, similar to panel **20** shown in **FIG. 4**, comprises a fibrous material layer **6** serving as the core which is bounded by fiberglass layers **22** and fleece layers **24**. The formulations for and variations of the fleece layer **24**, the fiberglass layers **22** and the fibrous material layer **6** may comprise the formulations described in the embodiment of panel **20** shown in **FIG. 4**. Laminated panel **30** further comprises a calendared surface **32**, and illustratively, a prime painted or coated surface **34**. The calendaring process assists in making a Class A finish for automobile bodies. A Class A finish is a finish that can be

exposed to weather elements and still maintain its aesthetics and quality. For example, an embodiment of the coated surface **34** contemplated herein is designed to satisfy the General Motors Engineering standard for exterior paint performance: GM4388M, rev. June 2001. The process for applying the painted or coated finish is described with reference to the calendaring process further herein below.

[0066] Further illustrative embodiment of the present disclosure provides a moldable panel material, for use as a headliner, for example, comprising the following constituents by weight percentage:

[0067] about 10 weight percent polypropylene fibers consisting of polypropylene (about 95 weight percent) coupled with maleic anhydride (about 5 weight percent), though it is contemplated that other couplers may work as well;

[0068] about 15 weight percent kenaf (or similar fibers such as hemp, flax, jute, etc.) fiber pre-treated with an anti-fungal/anti-microbial agent containing about 2 weight percent active ingredient; wherein the fibers may be pre-treated off-line prior to blending;

[0069] about 45 weight percent bi-component (about 4 denier) polyester fiber; wherein the bi-component blend ratio is about 22.5 weight percent high melt (about 440 degrees F.) polyester and about 22.5 weight percent low melt polyester (about 240 to about 300 degrees F. which is slightly below full melt temperature of polypropylene to permit control of polypropylene movement during heat phase); wherein, alternatively, like fibers of similar chemistry may also be used; and

[0070] about 30 weight percent single component polyester fiber (about 15 denier) high melt (about 440 degrees F.); wherein, alternatively, like fibers of similar chemistry may be used.

[0071] Again, such a material can be used as a headliner. This is because the formulation has a higher heat deflection created by stable fibers and high melt polypropylene, and by polyester and the cross-linked polymer to the polymer of the fibers. Furthermore, coupled polypropylene has cross-linked with non-compatible polyester low melt to form a common melt combined polymer demonstrating higher heat deflection ranges. The anti-fungal treated natural fiber protects any cellulous in the fiber from colonizing molds for the life of the product should the head liner be exposed to high moisture conditions.

[0072] It is appreciated that other formulations can work as well. For example, another illustrative embodiment may comprise about 40 percent bi-component fiber with 180 degree C. melt temperature, about 25 percent single component PET-15 denier; about 15 percent G3015 polypropylene and about 20 percent fine grade natural fiber. Another illustrative embodiment may comprise about 45 percent bi-component fiber semi-crystalline 170 degree C. melt temperature, about 20 percent single component PET-15 denier, about 15 percent low melt flow (10-12 mfi) polypropylene and about 20 percent fine grade natural fiber. It is further contemplated that such compositions disclosed herein may define approximate boundaries of usable formulation ranges of each of the constituent materials.

[0073] A cutaway view of a honeycomb composite panel **40** is shown in **FIG. 7**. The illustrated embodiment comprises top and bottom panels, **42, 44**, with a honeycomb core **46** located there between. One illustrative embodiment provides for a polypropylene honeycomb core sandwiched between two panels made from a randomly-oriented fibrous material. The fibrous material is illustratively about 30 weight percent fiber and about 70 weight percent polypropylene. The fiber material is illustratively comprised of about 50 weight percent kenaf and about 50 weight percent hemp. It is contemplated, however, that any hemp-like fiber, such as flax or other cellulose-based fiber, may be used in place of the hemp or the kenaf. In addition, such materials can be blended at any other suitable blend ratio to create such suitable panels.

[0074] In one illustrative embodiment, each panel **42, 44** is heat-compressed into the honeycomb core **46**. The higher polypropylene content used in the panels provides for more thermal plastic available for creating a melt bond between the panels and the honeycomb core. During the manufacturing of such panels **40**, the heat is applied to the inner surfaces **48, 50** of panels **42, 44**, respectively. The heat melts the polypropylene on the surfaces which can then bond to the polypropylene material that makes up the honeycomb core. It is appreciated, however, that other ratios of fiber to polypropylene or other bonding materials can be used, so long as a bond can be created between the panels and the core. In addition, other bonding materials, such as an adhesive, can be used in place of polypropylene for either or both the panels and the core, so long as the chemistries between the bonding materials between the panels and the core are compatible to create a sufficient bond.

[0075] A top detail view of the one illustrative embodiment of honeycomb core **46** is shown in **FIG. 8**. This illustrative embodiment comprises individually formed bonded ribbons **52**. Each ribbon **52** is formed in an illustrative battlement-like shape having alternating merlons **54** and crenellations **56**. Each of the corners **58, 60** of each merlon **54** is illustratively thermally-bonded to each corresponding corner **62, 64**, respectively, of each crenellation **56**. Such bonds **66** which illustratively run the length of the corners are shown in **FIG. 9**. Successive rows of such formed and bonded ribbons **52** will produce the honeycomb structure, as shown.

[0076] Another embodiment of the honeycomb composite panel comprises a fibrous material honeycomb core in place of the polypropylene honeycomb core. Illustratively, the fibrous material honeycomb core may comprise about 70 weight percent polypropylene with about 30 weight percent fiber, for example, similar to that used for top and bottom panels **42, 44**, previously discussed, or even a 50/50 weight percent mix. Such formulations are illustrative only, and other formulations that produce a high strength board are also contemplated herein.

[0077] A perspective view of a truss composite **70** is shown in **FIG. 10**. Truss panel composite **70** is a light weight, high strength panel for use in either two- or three-dimensional body panel applications. The illustrated embodiment of truss composite **70** comprises upper and lower layers **72, 74**, respectively, which sandwich truss member core **76**. Each of the layers **72, 74, 76** is made from a combination fibrous/polypropylene material, similar to

that described in foregoing embodiments. Each layer **72, 74, 76** comprises a non-directional fibrous material, illustratively, about 25 weight percent hemp and about 25 weight percent kenaf with the balance being polypropylene. The fibers are randomly oriented to provide a non-specific orientation of strength. Illustrative variations of this fibrous material are contemplated, which may include, for example, an approximately 24.75 weight percent hemp and 24.75 weight percent kenaf combination with 50 weight percent polypropylene and 0.05 weight percent maleic anhydride. Other ratios of fibrous materials, however, are also contemplated to be within the scope of the invention. In addition, other fibrous materials themselves are contemplated to be within the scope of the invention. Such materials may be flax, jute, or other like fibers that can be blended in various ratios, for example. Additionally, it is appreciated that other binders in place of polypropylene may also be used to accomplish the utility contemplated herein.

[0078] The truss core **76** is illustratively formed with a plurality of angled support portions **78, 80** for beneficial load support and distribution. In the illustrated embodiment, support portion **78** is oriented at a shallower angle relative to upper and lower layers **72, 74**, respectively, than support portion **80** which is oriented at a steeper angle. It is appreciated that such support portions can be formed by using a stamping die, continuous forming tool, or other like method. It is further appreciated that the thickness of any of the layers **72, 74**, or even the truss core **76** can be adjusted to accommodate any variety of load requirements. In addition, the separation between layers **72, 74** can also be increased or decreased to affect its load strength.

[0079] Between each support portion is an alternating contact portion, either **82, 84**. The exterior surface of each of the alternating contact portions **82, 84** is configured to bond to one of the inner surfaces **86, 88** of layers **72, 74**, respectively. To create the bond between layers **72, 74** and truss core **76**, superficial surface heat, about 450 degrees F. for polypropylene, is applied to the contact surfaces to melt the surface layer of polypropylene, similar to the process discussed further herein. At this temperature, the polypropylene or other binder material is melted sufficiently to bond same with the polypropylene of the core. In this illustrative embodiment, contact portion **82** bonds to the surface **86** of upper layer **72**, and contact portion **84** bonds to the surface **88** of layer **74**. Once solidified, a complete bond will be formed without the need for an additional adhesive. It is appreciated, however, that an adhesive may be used in place of surface heat bonding.

[0080] The outer surfaces of layers **72, 74** may be configured to accommodate a fascia cover stock (not shown). Such fascia cover stock may be comprised of fabric, vinyl, acrylic, leathers, epoxies, or polymers, paint, etc. In addition, the surfaces of layer **72, 74** may be treated with a polyester to waterproof the panel.

[0081] An end view of a hinged visor body **90** is shown in **FIG. 11a**. This disclosure illustrates a visor, similar to a sun visor used in an automobile. It is appreciated, however, that such a visor body **90** is disclosed herein for illustrative purposes, and it is contemplated that the visor does not represent the only application of a formed hinged body. It is contemplated that such is applicable to any other application that requires an appropriate hinged body.

[0082] In the illustrated embodiment, body 90 comprises body portions 92, 94 and a hinge 96 positioned therebetween. (See FIGS. 11b and 12b.) Body 90 is illustratively made from a low density fibrous material, as further described herein below. In one embodiment, the fibrous material may comprise a randomly-oriented fiber, illustratively about 50 weight percent fiber-like hemp or kenaf with about 50 weight percent polypropylene. The material is subjected to hot air and to variable compression zones to produce the desired structure. (See further, FIG. 13.) Another illustrative embodiment comprises about 25 weight percent hemp and about 25 weight percent kenaf with the balance being polypropylene. Again, all of the fibers are randomly oriented to provide a non-specific orientation of strength. Other variations of this composition are contemplated including, but not limited to, about a 24.75 weight percent hemp and about a 24.75 weight percent kenaf combination with about 50 weight percent polypropylene and about 0.05 weight percent maleic anhydride. Additionally, other fibrous materials are contemplated to be within the scope of this disclosure, such as flax and jute in various ratios, as well as the fibers in various other blend ratios. It is also appreciated that other binders in place of polypropylene may also be used for the utility discussed herein.

[0083] The illustrated embodiment of body 90 comprises hinge portion 96 allowing adjacent body portions 92, 94 to move relative to each other. The illustrative embodiment shown in FIGS. 11a and b depicts body 90 in the unfolded position. This embodiment comprises body portions 92, 94 having a thickness such that hinge portion 96 is provided adjacent depressions 98, 100 on the surface body portions 92, 94, respectively. Because body 90 is a unitary body, the flexibility of hinge portion 96 is derived from forming same into a relatively thin member, as herein discussed below. In such folding situations as shown in FIG. 12a, material adjacent the hinge may interfere with the body's ability to fold completely. These depressions 98, 100 allow body portions 92, 94 to fold as shown in FIG. 12a, without material from said body portions interfering therewith. As shown in FIG. 12b, a cavity 102 is formed when body portions 92, 94 are folded completely. It is contemplated, however, that such occasions may arise wherein it may not be desired to remove such material adjacent hinge portion 96, as depicted with depressions 98, 100. Such instances is contemplated to be within the scope of this disclosure.

[0084] In the illustrative embodiment shown in FIG. 11b, hinge portion 96 forms an arcuate path between body portions 92, 94. The radii assists in removing a dimple that may occur at the hinge when the hinge is at about 180 degrees of bend. As shown in FIG. 12b, hinge portion 96 loses some of its arcuate shape when the body portions 92, 94 are in the folded position. It is appreciated, however, that such a hinge 96 is not limited to the arcuate shape shown in FIG. 11a. Rather, hinge portion 96 may be any shape so long as it facilitates relative movement between two connecting body portions. For example, hinge portion 96 may be linear shaped. The shape of the hinge portion may also be influenced by the size and shape of the body portions, as well as the desired amount of movement between said body portions.

[0085] Illustratively, in addition to, or in lieu of, the fibrous material forming the visor hinge via high pressure alone, the hinge may also be formed by having a band of

material removed at the hinge area. In one illustrative embodiment, a hinge having a band width about 1/8 inch wide and a removal depth of about 70 weight percent of thickness mass allows the hinge full compression thickness after molding of about 0.03125 inch, for example. The convex molding of the hinge may straighten during final folding assembly, providing a straight mid line edge between the two final radiuses. It is contemplated that the mold for the mirror depressions, etc., plus additional surface molding details can be achieved using this process. It is further anticipated that the cover stock may be applied during the molding process where the cover is bonded to the visor by the polypropylene contained in the fibrous material formulation.

[0086] The illustrative embodiment of body 90 includes longitudinally-extending depressions 93, 95 which form a cavity 97. (See FIGS. 11a, 12a and 14a.) Cavity 97 is configured to receive bar 99, as discussed further herein. (See FIG. 14b.) It is appreciated that such depressions and cavities described herein with respect to body 90 are for illustrative purposes. It is contemplated that any design requiring such a moldable body and hinge can be accomplished pursuant the present disclosure herein.

[0087] As previously discussed, body 90 may be comprised of low density material to allow variable forming geometry in the visor structure, i.e., high and low compression zones for allowing pattern forming. For example, the panels portion may be a low compression zone, whereas the hinge portion is a high compression zone. In addition, the high compression zone may have material removed illustratively by a saw cut during production, if required, as also previously discussed. This allows for a thinner high compression zone which facilitates the ability for the material to be flexed back and forth without fatiguing, useful for such a hinge portion.

[0088] An end view of a die assembly 110 for compression molding a fiber material body and hinge is shown in FIG. 13. The form of the die assembly 110 shown is of an illustrative shape. It is contemplated that such a body 90 can be formed into any desired shape. In the illustrated embodiment, assembly 110 comprises illustrative press plates 112, 114. Illustratively, dies 116, 118 are attached to plates 112, 114, respectively. Die 116 is formed to mirror corresponding portion of body 90. It is appreciated that because the view of FIG. 13 is an end view, the dies can be longitudinally-extending to any desired length. This illustrative embodiment of die 116 includes surfaces 120, 122 and includes compression zones 124, 126, 128, 130. Zones 124, 126 are illustratively protrusions that help form the depressions 93, 95, respectively, of body 90, as shown. (See also FIG. 11a) Zones 128, 130 are illustratively protrusions that help form the depressions 98, 100, respectively, of body 90, as shown. (See also FIG. 11a.) And zone 132 is illustratively a form that, in cooperation with zone 134 of die 118, form hinge portion 96.

[0089] This illustrative embodiment of die 118 includes surfaces 136, 138 and includes compression zones 140, 142, 134. Zones 140, 142 are illustratively sloped walls that help form zone 134. (See also FIG. 11a.) Zone 134 is illustratively a peak that, in cooperation with zone 132 creates a high compression zone to form hinge portion 96, and, illustratively, depressions 98, 100, if desired. Again, it is

appreciated that the present pattern of such zones shown is not the only such pattern contemplated by this disclosure.

[0090] In the illustrated embodiment, body **90**, in the illustrative form of a hinged visor, is folded as that shown in **FIG. 12a**. It is further contemplated that during forming the body may be heated by hot air to bring it up to forming temperatures. The heating cycle time may be about 32 seconds, and the toll time after clamp for cool down will be around 45 to 50 seconds, depending on tool temperature. Furthermore, skins, like a fabric skin can be bonded to the visor during this step.

[0091] Another embodiment of the hardboard panel is a low density panel, illustratively, an approximately 2600 gram panel with about 50 weight percent fiber-like hemp, kenaf, or other fiber material with about 50 weight percent polypropylene. Such materials are subjected to hot air to produce a light-weight, low density panel. The panel material may be needle-punched or have a stretched skin surface applied thereon for use as a tackable panel, wall board, ceiling tile, or interior panel-like structure.

[0092] A portion of a dry-erase board **150** is shown in **FIG. 15**. Such a board **150** may comprise a hardboard panel **152** (similar to panel **2**) pursuant the foregoing description along with a surface coating **154**. The surface coating, as that described further herein, provides an optimum work surface as a dry-erase board. Surface coating **154**, for example, can be a Class A finish previously described. This illustrative embodiment includes a frame portion **156** to enhance the aesthetics of board **150**. One embodiment may comprise a dual-sided board with a low density tack board on one side and a dry-erase hardboard on the other side.

[0093] An illustrative embodiment of a work body in the form of a table top **180**, is shown in **FIG. 16**. The view illustrated therein is a partial cut-away view showing the mating of a top **182** to an underside **184**. An illustrative pedestal **186** supports table top **180** in a conventional manner. It is appreciated, however, that the table top **180** is shown in an exaggerated view relative to pedestal **186** so as to better illustrate the relevant detail of the table top **180**.

[0094] In the illustrated embodiment, the periphery **188** of top **182** is arcuately formed to create a work surface edging. The top **182** is attached to the underside **184** via a portion of the periphery **190** of the same mating with the top **182**. Periphery **190** illustratively comprises an arcuate edge portion **192** which is complementarily shaped to the interior surface **194** of periphery **188** of top **182**. Adjacent the arcuate edge portion **192** is an illustrative stepped portion **196**. Stepped portion **196** provides a notch **198** by extending the underside panel **202** of the underside **184** downward with respect to top **182**. Notch **198** provides spacing for edge **200** of periphery **188**. Such an arrangement provides an appearance of a generally flush transition between top **182** and underside **184**. Interior surface **194** of periphery **188** and outer surface **204** of periphery **190** can be mated and attached via any conventional method. For example, the surfaces can be ionize-charged to relax the polypropylene so that an adhesive can bond the structures. In addition, a moisture-activated adhesive can be used to bond the top **182** with the underside **184**.

[0095] Detailed views of the mating of top **182** and underside **184** is shown in **FIGS. 17 and 18**. The conformity

between peripheries **188** and **190** are evident from these views. Such allows sufficient bonding between top **182** and underside **184**. The generally flush appearance between the transition of top **182** and underside **184** is evident as well through these views. The variations between illustrative embodiments are depicted in **FIGS. 17 and 18**. For example, top surface **206** is substantially coaxial with level plane **208** in **FIG. 17**, whereas top surface **206** is angled with respect to level plane **208**. It is appreciated, as well, that the disclosure is not intended to be limited to the shapes depicted in the drawings. Rather, other complementarily-shaped mating surfaces that produce such a transition between such top and bottom panels are contemplated to be within the scope of the invention herein.

[0096] Such mating of top **182** and underside **184** may produce a cavity **210**, as shown in **FIGS. 16 through 19**. Depending on the application, cavity **210** may remain empty, or may contain a structure. For example, **FIG. 19** shows an end view of table top **180** with a truss member core support **76** illustratively located therein. Truss member core **76** can be of the type previously described and be attached to the interior surfaces **194**, **212** via conventional means, such as an adhesive, for example. Such a core structure can provide increased strength to table top **180**. In fact, such strength can expand the uses of the work body to other applications in addition to a table top. For example, such can be used as a flooring, or side paneling for a structure or a vehicle. It is contemplated that other such cores can be used in place of the truss member. For example, a foam core or honeycomb core can be used in place of the truss.

[0097] An illustrative hardboard manufacturing line **300** is shown in **FIGS. 20 through 28**. Line **300** is for manufacturing laminated hardboard panels of the type shown in **FIGS. 1 through 3**, and indicated by reference numeral **2**, for example. The manufacturing process comprises the mating of the several layers of materials, illustratively layers **6** and **8** (see **FIG. 1**), heating and pressing said layers into a single laminated composite panel, cooling the panel, and then trimming same. In the illustrative embodiment, line **300** comprises the following primary stages: uncoiling and mating **302** (**FIG. 22**), pre-heating **304** (**FIG. 23**), heat and press **306** (**FIG. 24**), cooling **308** (also **FIG. 24**), laminating station (**FIGS. 25 through 28**), and shear and trim **310** (also **FIGS. 25 through 28**.) A top view of line **300** is shown in **FIG. 21**. It is appreciated that the line **300** may be of a width that corresponds to a desired width of the composite material. **FIG. 21** also illustrates the tandem arrangement of each of the stages **302**, **304**, **306**, **308**, **310**.

[0098] The uncoiling and mating stage **302** is shown in **FIG. 22**. In the illustrative embodiment, the materials used for forming the composite are provided in rolls. It is appreciated that the materials may be supplied in another manner, but for purposes of the illustrated embodiment, the material will be depicted as rolls. Illustratively, stage **302** holds rolls of each illustrative layer **6** and **8** in preparation for mating. As illustrated, stage **302** comprises a plurality of troughs **312** through **320**, each of which being illustratively capable of holding two rolls, a primary roll and a back-up roll, for example. In one embodiment, it is contemplated that any number of troughs can be used, and such number may be dependent on the number of layers used in the laminated body.

[0099] For this illustrative embodiment, line 300 is configured to manufacture a laminated composite panel 2 similar to that shown in FIGS. 1 through 3. It is appreciated, however, that the utility of line 302 is not limited to making only that panel. Rather, such a line is also capable of manufacturing any laminated panel that requires at least one of the stages as described further herein. Troughs 312, 316, and 320 each comprise a primary roll 6' and a back-up roll 6" of layer 6. In this example, layer 6 is illustratively a non-oriented fibrous material. Similarly, troughs 314 and 318 each comprise a primary roll 8' and a back-up roll 8" of layer 8 which is illustratively the woven fiber layer. Each roll rests on a platform system 322 which comprises a sensor 324 and a stitching device 326. Sensor 324 detects the end of one roll to initiate the feed of the back-up roll. This allows the rolls to create one large continuous sheet. For example, once fibrous material primary roll 6' is completely consumed by line 302, and sensor 324 detects the end of that primary roll 6' and causes the beginning of back-up roll 6" to join the end of primary roll 6'. This same process works with primary roll 8' and back-up roll 8" as well.

[0100] To secure each roll of a particular material together, stitching device 326 stitches, for example, the end of primary rolls 6' or 8' with the beginning of the back-up rolls 6" or 8", respectively. The stitched rolls produce a secure bond between primary rolls 6', 8' and back-up rolls 6" and 8", respectively, thereby forming the single continuous roll. Illustratively, stitching device 326 trims and loop stitches the ends of the materials to form the continuous sheet. Also, illustratively, the thread used to stitch the rolls together is made from polypropylene or other similar material that can partially melt during the heating stages, thereby creating a high joint bond in the final panel. It is contemplated, however, any suitable threads can be used which may or may not be of a polymer.

[0101] Each trough of stage 302 is configured such that, as the material is drawn from the rolls, each will form one of the layers of the laminated composite which ultimately becomes the hardboard panel. Fibrous material layer 6 of primary roll 6' from trough 312 illustratively forms the top layer with the material from each successive trough 314 through 320, providing alternating layers of layers 6 and 8 layering underneath, as shown exiting at 321 in FIG. 22. Each roll of material is illustratively drawn underneath the troughs exiting in direction 327. The resulting layered materials exit stage 302 at 321, pass over bridge 328, and enter the pre-heating stage 304.

[0102] Pre-heat stage 304, as shown in FIG. 23, comprises an oven 323 which forces hot air at approximately 240 degrees F. into the composite layers. Oven 323 comprises a heater-blower 330 which directs heated air into composite chamber 332 which receives the material layers. This hot air removes moisture from layers 6, 8, as well as heats the center-most layers of the same. Because often such materials are hydrophobic, the removal of the moisture causes the center of the materials to cool. The forced heat causes the center to be warmed, even while the moisture is being removed. This pre-heat allows the process to become more efficient during the heat and press stage 306. Stage 308 illustratively comprise a roller/belt system which includes rollers 333 that move belts 335, as shown in FIG. 23. Illustratively, these belts are located above and below the

panel 2, defining at least a portion of chamber 332. Belts 335 assist in urging panel 2 through stage 304 and on to stage 306.

[0103] The preheated composite layers exit through opening 334 of stage 304 and enter the heat and press stage 306, as shown in FIG. 24. The pre-heated composite panel 2 enters stage 306 through opening 336 and into chamber 337. The heat and press stage 306, uses a progression of increasingly narrowly-spaced rollers located between heat zones, thereby reducing the vertical spacing in chamber 337. The combination of the heat and the narrowing rollers reduces the thickness of panel 2 transforming same into a laminated composite panel 2 of desired thickness. For example, stage 306 comprises pairs of spaced rollers 338, 340, 342, 344, 346, 348 through which the composite layers pass. The rollers are linearly spaced apart as shown in FIG. 24. In one illustrative embodiment, to make a 4 millimeter panel, rollers 338 will initially be spaced apart about 15 millimeters. Successively, rollers 340 will be spaced apart about 12 millimeters, rollers 342 will be spaced apart about 9 millimeters, rollers 344 will be spaced apart about 6 millimeters, and finally, rollers 346 and 348 will be each spaced apart about 4 millimeters. This gradual progression of pressure reduces stress on the rollers, as well as the belts 350, 352 driving the rollers. Such belts 350, 352 generally define the top and bottom of chamber 337 through which panel 2 travels. Because of the less stress that is applied to belts 350 and 352 which drive rollers 338, 340, 342, 344, 346, 348, such belts 350, 352 can be made from such materials as Teflon glass, rather than conventional materials such as a metal. The Teflon belts absorb less heat than metal belts do, so more of the heat generated will be transferred to the lamination of panel 2, in contrast to production lines using conventional metal belts. In one illustrative embodiment, stages 306 and 308 are approximately 10 meters long and approximately 4 meters wide.

[0104] In one illustrative embodiment, located between every two pairs of rollers are a pair of surfaces or platens 354, 356 between which the panel 2 moves during the lamination process. Illustratively, platens 354, 356 receive hot oil or similar fluid. It is appreciated, however, that other methods of heating the platens can be used. In the present embodiment, however, the hot oil causes the platens 354, 356 to raise the core temperature of the panel 2 to about 340 degrees F. The combination of the compression force generated by the rollers 338, 340, 342, 344, 346, 348 and the heat generated by the platens 354, 356 causes the polypropylene in the material layers 6, 8 to melt, causing same to begin fusing and compacting into the panel 2 of desired thickness.

[0105] After the layers 6, 8 of the composite panel 2 is heated, fused, and reduced to a desired thickness, the resulting composite panel 2 is cooled at cooling stage 308. In the illustrated embodiment, cooling stage 308 is an extension of the heat and press stage 306 to the extent that stage 308 also includes pairs of rollers 358, 360, 362, 364, 366 which are similarly situated to, and arranged linearly with, rollers 338, 340, 342, 344, 346, 348. The space between each of the rollers is about the same as the space between the last pair of rollers of the heat and press stage 306, in this case rollers 348. In the forgoing example, the rollers 348 were illustratively spaced apart about 4 millimeters. Accordingly, the spacing between the rollers of each pair of rollers 358, 360,

362, 364, 366 of stage **308**, through which the panel passes, is also spaced apart about 4 millimeters. Cooling stage **308** treats platens **372** through **406** that are cooled with cold water, illustratively at approximately 52 degrees F., rather than being treated with hot oil, as is the case with heat and press stage **306**. This cooling stage rapidly solidifies the melted polypropylene, thereby producing a rigid laminated hardboard panel **2**.

[**0106**] Hardboard panel **2** exits the cooling stage **308** at exit **408**, as shown in **FIG. 24**, and enters the shear and trim stage **310**, as shown in **FIGS. 25 through 28**. In one illustrative embodiment, composite panel **2** passes through an interior wall laminating stage **410** and into the trim and cutting stage **412**. When panel **2** passes through stage **412**, its edges can be trimmed to a desired width and the panel cut to any desired length with the panel exiting to platform **414**. A top view of line **300** is shown in **FIG. 21** which includes the various aforementioned stages **302, 304, 306, 308, 310** as well as finishing a stage **416**. This stage **416** is illustratively for applying an acrylic or other like resin finish to the surface of the composite panel. Specifically, once such a composite panel **2** exits the shear and trim stage **310**, it is supported on a plurality of rollers **418** and placed along the length of platform **414** to move panel **2** in direction **420**. In one illustrative embodiment, panel **2** may be rotated into position, as shown in **FIG. 28**, to finishing stage **416**. To rotate panel **2**, movable catches **422, 424**, one at the proximal end of platform **414** and the other at the distal end of platform **414**, as shown in **FIGS. 21 and 28**, both move concurrently to move panel **2**. Catch **422** moves a corner of panel **2** in direction **420** while catch **424** moves the other corner of panel **2** in direction **426**, ultimately positioning panel **2** on platform **415** at stage **416**. It is appreciated, however, that it is not required to locate such a finishing stage at an angle relative to line **300**. Alternatively, stage **416** may be located linearly with the remainder of line **300**.

[**0107**] Illustratively, before applying the acrylic finish to panel **2** at stage **416**, its surface is first prepared. The illustrative process for preparing the surface of panel **2** is first sanding the surface to accept the finish coat. After sanding the surface of panel **2**, a wet coating of the resin is applied. Illustratively, the resin is polyurethane. The acrylic resin can then be UV cured, if necessary. Such curing is contemplated to take as much as 24 hours, if necessary. Initial cooling, however, can take only three seconds. Such an acrylic coating has several uses, one is the dry-erase board surface, previously discussed, as well as exterior side wall panels for recreational vehicles and pull type trailers. It is further contemplated herein that other surface coatings can be applied at stage **416** as known by those skilled in the art.

[**0108**] In another illustrative embodiment, interior wall laminating stage **410**, though part of line **300**, can be used to create wall panel composites from panel **2**. When making such panel, rather than panel **2** passing through stage **410**, as previously discussed panel **2** is laminated at stage **410**. In this illustrative embodiment, as shown in **FIGS. 25 and 26**, for example, stage **412** comprises an uncoiling hopper **430**, a hot air blower **432**, and a roller stage **434**. Hopper **430** is configured to support illustratively two rolls of material. For this illustrative embodiment, a base substrate layer **436**, and a finish surface material layer **438** is located in hopper **430**. It is appreciated that the base substrate layer **436** can be any

suitable material, including the fibrous material layer **6** as previously discussed or a priming surface material. The finish surface material layer **438** can be of any finishing or surface material such as vinyl, paper, acrylic, or fabric. Uncoiling hopper **430** operates similar to that of stage **302** to the extent that they both uncoil rolls of material. Hopper **430** operates differently from stage **302**, however, to the extent that both layers **436** and **438** uncoil concurrently, rather than in tandem, like rolls **6'** and **6''**, for example. In other words, both layers **436, 438** will form the layers of the composite top coat, rather than form a single continuous layer for a board, as is the case with roll **6'** and **6''**.

[**0109**] In the illustrative embodiment, base substrate layer **436** uncoils below the finish surface material layer **438**, as shown in **FIGS. 26 and 27**. In addition, both layer **436** and layer **438** form a composite as they enter roller stage **434**. The hot air blower **432** blows hot air **448** at approximately 450 degrees F. in direction **448** between layer **436** and layer **438**. This causes the surfaces, particularly the base material layer **436** surface, to melt. For example, if the base substrate layer **436** is fibrous material layer **6**, the polypropylene on the surface of this material melts. As layer **436** and layer **438** pass between a pair of rollers **450** at the roller stage **434**, the melted polypropylene of layer **436** bonds with the layer **438**, forming a composite of fibrous material having the finish surface material **438**. After the materials have formed a laminated composite, they can then proceed to the shear and trim stage **310**.

[**0110**] It is contemplated that finish surface material layer **438** may comprise several finish materials applied to base material layer **436** either concurrently or in tandem. For example, a roll of material layer **438** may comprise a roll that includes a section of vinyl, attached to a section of paper, and then fabric, and then vinyl again. Uncoiling this roll and bonding it to layer **436** produces a single composite board having several tandemly positioned finish surfaces that can be sheared and cut at stage **310** as desired.

[**0111**] Another illustrative hardboard manufacturing line **500** is shown in **FIGS. 29 and 30**. Line **500** is another embodiment for manufacturing laminated hardboard panels of the type illustratively shown in **FIGS. 4 through 6**. This manufacturing line **500** is similar to manufacturing line **300** previously discussed, wherein process **500** comprises the mating of several layers of materials, illustratively layers **22, 24**, as well as the calendaring surface **32** and coated surface **34**, as shown illustratively in panel **30** of **FIG. 6**. Manufacturing line **500** comprises the following panel manufacturing stages: the uncoiling and mating stages **502**, the pre-heating stage **504**, the heat and press stage **506**, the cooling stage **508**, the calendaring stage **510**, and the shear and trim stage **512**.

[**0112**] One illustrative embodiment of line **500** comprises a calendaring stage **510**. This stage is located in the same location as the laminating stage **410** of line **300**, as shown in **FIG. 25**. The purpose of the calendaring stage is to smooth the top surface of the illustrative panel **30** to prepare it for the paint application of line **514**. Conventionally, using belts **350, 352** in conjunction with the heated platens may cause the texture of those belts, similar to a cloth pattern, to be embedded in the surfaces of the panel **30**. (See, also, **FIG. 24**.) The calendaring process removes this pattern to provide a smoother surface in anticipation of the paint application. In

the illustrated embodiment shown in **FIG. 30**, calendaring stage **510** comprises a conveying line **570** and spaced apart rollers **572**, as well as a heat source **574**. As panel **30** exits the cooling stage **508**, it is transferred to the calendaring stage **510** where the heat source, illustratively infrared heat or heated air, or a combination of both, is applied to the surface of the panel **30**. Panel **30** is then directed between the two spaced apart rollers **572** which will then smooth the surface that has been heated by heater **574**. In one embodiment, it is contemplated that at least one of the rollers is temperature controlled, illustratively with water, to maintain the rollers up to an approximate 120 degrees F. It is further contemplated that the heated air or IR heater is controlled to only heat the surface of panel **30** and not the center of the board itself. Furthermore, it is contemplated that the roller can subject up to an approximate 270 pounds per linear inch force on the surface of the panel **30** in order to smooth out any pattern in the surface and/or related defects thereon to produce a calendared surface **32** as previously discussed with respect to **FIG. 6**. It will be appreciated that this calendaring process will prepare the surface **32** of panel **30** so that it may receive a Class A auto finish. Once the panel **30** exits the calendaring stage **510**, it then is transferred to the shear and trim stage **512** where the panel will take its final shape prior to the paint stage.

[0113] In contrast to manufacturing line **300**, however, line **500** further comprises paint application line **514**. Paint line **514** comprises a transfer conveyer **516** which moves panels, in this illustrative case panel **30**, from the shear and trim stage **512** to the paint line **514**. This is accomplished illustratively by rollers on conveyer **518** moving panel **30** perpendicularly from shear and trim stage **512** to paint line **514** which is illustratively positioned parallel to line **500**. If, for example, panel **30** or the other panels **20** and **28** do not receive a paint application, they can be removed from the line at an off-load point **520**. If panel **30**, for example, will be receiving a paint application, it is loaded onto paint line **514** via a staging section **522** as shown in **FIG. 29**. The first stage of the paint process of paint line **514** is to flame treat the top surface of panel **30** at **524**. The flame treatment process is a means to relax the surface tension and ionize-charge the board for chemical bonding. This will decrease the surface tension of the plastic or the bonding material. Such decrease in surface tension allows the plastic to have a similar surface tension to that of the paint that will create better adhesion of the paint to the board. In the illustrative embodiment, the flame treatment uses a blue flame approximately $\frac{1}{4}$ inch in height, and the board is passed below the flame of about $\frac{3}{8}$ of an inch at a rate of about 26 feet per minute. It is appreciated, however, that other means of heating the surface of panel **30** is contemplated and, in regards to the flame size, temperature, and the distance of the board from the flame, is illustrative and not considered to be the sole embodiment of this disclosure.

[0114] It is contemplated that much of the paint line will be enclosed and, because of such, after the flame treatment stage **524**, an air input section is added to create positive pressure within the line. In the illustrative embodiment, a fan is added to this section to input air which will blow dust and debris away from the panel to keep it clean. The next stage of paint line **514** is the adhesion promoter spray booth **528**. Booth **528** applies a plastic primer to the surface of panel **30** that integrates with the plastic in the board to assist in better adhesion of subsequent paint layers. In this illustrative

embodiment, a down-draft spray of the primer is applied to the surface of panel **30**. Exiting booth **528**, another air input section **530** is illustratively located to further create positive pressure to continue preventing dust or other contaminants from resting on the surface of the panel.

[0115] After panel **30** exits the adhesion promoter booth **528**, it enters the UV primer seal spray booth **532**. Booth **532** applies a UV filler paint to further level the surface of the panel **30**, as well as serve as an additional primer for the final UV cure paint. It is appreciated, however, that depending on the application of the panel, the UV filler can be replaced with a UV paint or other paint as a topcoat. In this illustrative embodiment, however, the booth **532** uses a down-draft spray to apply the primer seal onto panel **30**.

[0116] Exiting booth **528**, panel **30** then enters an ambient flash stage **534** wherein the panel **30** rests to allow solvents from the paint to evaporate. Though not shown, the solvents are drawn from the ambient flash stage **534** where the solvents are burned so as to not enter the atmosphere. In addition, stage **534** may include an input fan **536**, similar to air inputs **526** and **530**, to maintain positive pressure in this section.

[0117] After allowing the solvents to dissipate from the surface of the panel **30**, it is transported under a UV cure lamp **538** to further cure the paint. The UV cure **538** is illustratively a high-intensity, ultra-violet light to which the paint is sensitive, and which will further cure the paint.

[0118] After passing through UV cure **538**, the panel **30** is passed through an infrared oven **540**. The panel **30** is moved through oven **540** at an illustrative rate of 2.5 meters per minute and the IR oven is set at about 165 degrees F. This step further assists to drive out any remaining solvents that might not have been driven out prior to the UV cure. In addition, those solvents are also then sent off and burned before reaching the atmosphere.

[0119] Once exiting the IR oven **540**, panel **30** is transferred to a side transfer section **542** which allows either removal of panel **30** if the paint applied at booth **532** was the final application of paint, or through conveyors **544** as shown in **FIG. 29**, if panel **30** is to be transferred to a secondary paint line **546**.

[0120] If panel **30** is transferred to secondary paint line **546**, it is passed through another spray booth **548**. Booth **548** uses a down-draft spray to apply a UV topcoat over top the UV filler and adhesion promoter coats previously discussed. The UV topcoat will be the finished coat that provides the Class A auto finish as previously discussed, for example. Once the topcoat has been applied onto the surface of panel **30**, the following process is similar to that as described with respect to paint line **514** which is that the panel **30** is again subjected to an ambient flash at section **550**, similar to ambient flash stage **534** previously discussed, wherein the solvents are allowed to evaporate, and are driven off and burned. Furthermore, the panel is transferred through a UV cure **552** section, similar to that of **538** and as previously discussed, the UV cure **552** serves also as UV high-intensity light to further cure the topcoat applied at **548**. After passing through the UV section **552**, panel **30** then enters infrared oven **554**, which is similar to IR oven **540** previously discussed, wherein the panel is subjected to a temperature of about 165 degrees F. for about 2.5 minutes.

[0121] When panel 30 exits the IR oven, it enters an inspection booth 556 where the surface is inspected for defects in the paint or in the board. The inspection can be either manually accomplished by visual inspection of the surface and identifying such defects, or can be accomplished through an automated inspection process comprising sensors to locate defects, etc. In addition, the inspection booth 556 also serves as a cool-down process for the process. The inspection booth 556 maintains a temperature of about 78 degrees F. with about 50 weight percent relative humidity to cool down at least the surface of the board from the approximate 165 degrees F. from the IR oven to about 80 degrees F. If a board does not pass inspection, it will be removed for repair or recycling. If the board does pass inspection, it will pass through a pinch roller 558 that will apply a slip sheet which is illustratively a thin 4 millimeter polypropylene sheet that protects the painted surface of panel 30 and allow the same to be stacked at the off-load section 560.

[0122] Composite materials, like those used to manufacture automobile bodies and interiors, have the potential to be recycled into new materials. An impediment to such recycling, however, is incompatible particle sizes of otherwise potentially recyclable constituents. For example, a variety of combinations of polypropylene, vinyl, polyester, ABS, and fibrous materials may be used to produce a panel or core product for a panel.

[0123] In the recycle system 600, shown in FIGS. 31 through 33, several materials are collected and segregated based on a desired composition at 602. Each material is granulated to reduce its particle size. The degree to which each material is granulated can be varied depending on the chemistry desired in the resulting panel. After each material is granulated, the loss and weight is determined at 604. This is done so that the cross-section and weight can be controlled before the resultant material is laminated into a panel. The materials are blended into a composition at 606 and transferred to collector 608. The composition is then transferred from collector 608 through a metal detector 612 which is configured to remove metal particles. The remaining composition is then deposited into a scatter box 614. Scatter box 614 allows particles of a particular maximum size to deposit onto granulate belt 616. The loss and weight of the resulting composition is then determined again to maintain the density of the final panel. The composition is then transferred to the recycle composition storage 626 in anticipation for deposit with the other laminate constituents.

[0124] The recycled composition manufacturing panel line 618, shown in FIGS. 32 and 33, is similar to line 300 shown in FIG. 20. Line 618 comprises the following primary stages: uncoiling 620, pre-heater 622, heat and pressure 624, recycled material storage 626, cooling 628, shear and trim 630. In the illustrated embodiment of FIG. 32, rolls 632, 634 of material, such as a fibrous or woven glass material, for example, are located at stage 620. Rolls 632, 634 are uncoiled to form composite layers. These layers are then pre-warmed using pre-heater stage 622, similar to stage 304 used in manufacturing line 300. The recycled composition material from stage 626 exists in the form of chips having an irregular shape with a maximum dimension in any one direction of, illustratively, 0.125 inches, and is then deposited between the composite layers. The new composite layers are then subjected to the same heat, pressure, and

cooling at stages 624 and 628, respectively, as to the heat and press stage 306 and the cooling stage 308 of manufacturing line 300.

[0125] The heat and pressure stage 624 receives the pre-heated composite layers, and through a progression of increasingly narrowly-spaced rollers, compresses the composite layers to a desired thickness similar to that previously discussed. Again, this gradual progression of pressure reduces stress on the rollers and the belts driving the rollers, as discussed with stage 306 of line 300. In addition, the belts that drive the rollers can, too, be made of Teflon glass material, rather than a metal, also previously discussed. Also similar to stage 308, stage 628 includes a pair of surfaces or platens between every two pairs of rollers to allow the composite layer to move there between. Illustratively, the platens receive hot oil. It is appreciated that other methods of heating the platens are contemplated, similar to stage 306. After the composite layers are heated, fused, and reduced to a desired thickness, the resulting panel is cooled. Cooling stage 628 is comparable to stage 308. The final stage is shear and trim 630, which is also similar to the shear and trim stage 310 of line 300.

[0126] As shown in FIGS. 32 and 33, line 618 further includes a dual side lamination stage 636. Stage 636 is similar to stage 410, shown in FIG. 25, except for the additional uncoiling stage 638 located beneath a primary uncoiling stage 637. It is contemplated that applying a surface on both sides of a composite panel is the same as applying a single surface, as shown in FIG. 20, with the exception that warm air will be directed to both sides of the composite panel. The process as shown in FIG. 20 does apply to the lower surface as well.

[0127] A sectional view of fibrous substitute material layer 6 is shown in FIGS. 36a through c. The distinction between the views of FIGS. 36a through c is the amount of heat and pressure applied to fibrous material layer 6. As previously discussed above, fibrous material layer 6 illustratively comprises a mat of illustratively about 25 weight percent hemp and about 25 weight percent kenaf with the balance being illustratively polypropylene. The fibers are randomly oriented to provide a nonspecific orientation of strength. Variations of this fibrous material are contemplated, including an about 24.75 weight percent hemp and about 24.75 weight percent kenaf combination with about 50 weight percent polypropylene and about 0.05 weight percent maleic anhydride. Other such fibrous materials can be used as well, such as flax and jute, for example. It is also contemplated that other blend ratios of the fibrous material can be used. It is further contemplated that other binders in place of polypropylene may also be used for the purpose discussed further herein. Still further, it is contemplated that other fibrous materials which have high process temperatures in excess of about 400 degrees F., for example, may be used as well.

[0128] The fibrous material layer 6 shown in FIG. 36a is considered a virgin version of the layer, similar to that shown in FIG. 1, or on rolls 6' and 6" shown in FIG. 22. This version of layer 6 is considered virgin, because it has not been subjected to a heat treatment or was compressed. The fibers and the binder that compose the layer exist as essentially separate constituents simply mixed together. In this state, the virgin version is highly permeable and pliable. The relative thickness 700 of the layer 6 is relatively greater

than the thicknesses **702** or **704** of layers **6** shown in either **FIGS. 7b** and **7c**, respectively. Furthermore, because the binder, polypropylene, for example, is not bound to the fiber, heating layer **6** may cause it to consolidate or shrink, particularly in its length and width.

[**0129**] In contrast, layer **6** shown in **FIG. 36c**, though comprising the same constituents as layer **6** in **FIG. 36a**, has been subjected considerably to heat and pressure. This embodiment of layer **6** is considered a high density version. In this case, the binder has been fully wetted-out. Fully wetted-out, for the purposes of this discussion means that the binder has, for practical purposes, all liquefied and bonded to the fibrous material of layer **6**. Such produces an essentially non-permeable, dense and rigid body. The binder, typically a thermal melt polymer, like polypropylene, is melted into a liquid state, causing the polymers to adhere to and/or wet-out the fibrous materials. This can produce a consolidation of the composite when cooled which shrinks the layer. This results, however, in a rigid and dimensionally stable flat sheet. If such a layer is then reheated, because the binder is already bonded with the fibrous material, the layer will not shrink, unlike the layer **6** described in **FIG. 36a**. Such high density layers are used to produce the layers **72**, **74** of truss composite **70**, previously discussed with respect to **FIG. 10**, for example.

[**0130**] The version of layer **6** shown in **FIG. 36b**, in contrast to both the virgin and high density versions from **FIGS. 36a** and **c**, respectively, is considered a low density version. This low density version has been subjected to heat and pressure, so that a portion of the binder in the layer has been wetted-out, unlike the virgin version of **FIG. 36a** which has not been subjected to such a process. Furthermore, unlike the high density layer shown in **FIG. 36c**, the binder of the low density layer has not been fully wetted-out. In other words, not all of the binder in the low density layer has liquefied and bonded to the natural fibers, only a portion of the binder has. The remaining binder is still maintained separate from the fibrous material. This makes the low density version rigid, similar to the high density version, yet, also semi-permeable, more akin to the virgin version. In one illustrative embodiment, the binder has melted and soaked into about 50 percent of the fibers that are in the layer. In this case, it is not believed that the fibers per se have grown, nor changed in a specific value. Rather, the fibers have just absorbed the binder.

[**0131**] The low density version can provide accelerated processing for three-dimensional molding, particularly in molding, like that shown in **FIGS. 11** and **12**, where various compression zones are used to form the material. Furthermore, utilizing such a composite provides lower production costs. In addition, because the layer is rigid, yet has some permeability, it can be used as a tack board alone or in conjunction with the dry erase board **150** of **FIG. 15**, for example. The properties also make it conducive to acoustical insulation or ceiling tiles.

[**0132**] Conventional heat sources such as infra red ovens are not used to heat a high density layer **6** material, because it may cause changes to its physical dimensions or cause overheating of the surface area of the high density layer **6** in order to bring the core up to proper processing temperatures. In contrast, contact heating ovens, which use upper and lower heated platens to hold a virgin layer **6** under pressure

during heating to prevent significant shrinkage, are not readily available in the general molding industry that may use such materials. Furthermore, the target cycle times required to heat these layers to molding temperatures require extra energy and equipment.

[**0133**] Using the low density version of layer **6** can, on balance, be a more cost effective way to mold such fibrous material layers. For example, an 1800 gram per meter square sample of fibrous material, as described with respect to **FIGS. 26a** through **c**, may require about 83 seconds of heat time in a contact oven to get the virgin version up to molding temperature. The high density version may require 48 seconds of heat time in an IR oven. The low density board, however, may require only about 28 seconds of heat time in an air circulated hot air oven. This is to reach a core temperature of about 340 to 350 degrees F.

[**0134**] When heating the low density version in a simple air circulated hot air oven, the energy required to heat low density board is 50 percent less than the required energy to heat the layer through a contact oven and 70 percent less than the required energy to heat a consolidated hard board utilizing infra red oven. The high density layer is typically only heated by an infrared oven. This is because the high density version does not have the permeability for hot air, and contact ovens may overheat and damage the layer.

[**0135**] Some benefits of the high density version over the virgin version are also found in the low density version. First of all, similar to how the high density version requires less packaging space than the virgin because of its reduced thickness, the low density version too requires less packaging space since its thickness is also less than that of the virgin version. Such translates into reduced shipping costs. Secondly, because the low density version is rigid, like the high density version, the low density version can be handled much easier with mechanical devices, such as grippers and clamps. This can be more difficult with the virgin version which is more pliable. Also, the low density material does not always have to be pre-heated. Some applications of the virgin version may require the layer to be preheated so as to dimensionally stabilize the material. This is not necessary with the low density version. In contrast, for those production lines that use a needle system to handle materials, particularly, for materials like the virgin version of layer **6**, the high density version would not receive such needles, because of the solidified binder. The low density version, however, still being semi-permeable, may receive such needles, allowing it to be transported easily, similar to that of the virgin version.

[**0136**] Manufacture of the low density version like that shown in **FIG. 36c** comprises subjecting the virgin version to both heat and pressure. The heat and pressure is illustratively provided by an oven which comprises compressed rolls that pinch the material to reduce its ability to shrink while it is being heated. The rolls have belts with holes disposed therethrough, through which the hot air passes. The layer is being held as structurally rigid as possible so it does not suck-in and become narrow and thick in the middle. The heat and pressure causes the binder to liquefy, and under the rollers, causes the melted binder to be absorbed into and surround the natural fiber. The layer may shrink to some minor extent, but that can be compensated for during this manufacturing process. When the layer is removed from the oven, cold air is blown on it to solidify the layer.

[0137] Typically, thermal melt polymers are heat sensitive, and at temperatures above 240 degrees F. will attempt to shrink (deform). Therefore, the opposing air permeable belts having opposing pressures limits the amount of heat sink shrinkage that will occur during this process. Once the initial heating has occurred (polymers changed from a solid to liquid state), and consolidation of thermal melt and non-thermal melt fibers are achieved, the consolidated layer 6 becomes thermal dimensionally stable. After heating, and while the consolidated mat is under compression between the opposing air permeable belts, the layer is chilled by ambient air being applied equally on opposite sides of the consolidated mat to, again, bring the thermal melt polymers back to a solid state.

[0138] Although the present disclosure has been described with reference to particular means, materials and embodiments, from the foregoing description, one skilled in the art can easily ascertain the essential characteristics of the present disclosure and various changes and modifications may be made to adapt the various uses and characteristics without departing from the spirit and scope of the present invention as set forth in the following claims.

What is claimed is:

1. A fibrous moldable substrate comprising:
 - a mat comprising a fibrous material and a binder;
 - wherein fibers of the fibrous material are randomly oriented; and
 - wherein the fibrous material and binder is subjected to heat such that only a portion of the binder is wetted to the fibrous material.
2. The fibrous moldable substrate of claim 1, wherein the fibrous material is hemp.
3. The fibrous moldable substrate of claim 1, wherein the fibrous material is kenaf.
4. The fibrous moldable substrate of claim 1, wherein the fibrous material comprises hemp and kenaf.
5. The fibrous moldable substrate of claim 4, wherein the fibrous material comprises about 50 weight percent hemp and 50 weight percent kenaf.
6. The fibrous moldable substrate of claim 1, wherein the mat comprises about 25 weight percent hemp, about 25 weight percent kenaf and about 50 weight percent the binder.
7. The fibrous moldable substrate of claim 1, wherein the binder is a thermomelt binder.
8. The fibrous moldable substrate of claim 7, wherein the binder is polypropylene.
9. The fibrous moldable substrate of claim 1, wherein the mat comprises about 24.75 weight percent hemp, about 24.75 weight percent kenaf, about 50 weight percent a polypropylene binder material and about 0.05 weight percent maleic anhydride.
10. The fibrous moldable substrate of claim 1, wherein the mat is subjected to a compression force where its cross-section is reduced.
11. The fibrous moldable substrate of claim 1, wherein the mat experiences insubstantial two-dimensional shrinkage while being subjected to the heat.

12. The fibrous moldable substrate of claim 1, wherein the fibrous material is selected from a group comprising hemp, kenaf, flax and jute.

13. A fibrous moldable substrate comprising:

a mat comprising a fibrous material and a binder;

wherein fibers of the fibrous material are randomly oriented;

wherein the fibrous material and binder is subjected to heat such that only a portion of the binder is wetted to the fibrous material; and

wherein the binder become dimensionally stable when cooled.

14. The fibrous moldable substrate of claim 13, wherein the fibrous material is at least semi-rigid.

15. The fibrous moldable substrate of claim 12, wherein the fibrous material is hemp.

16. The fibrous moldable substrate of claim 13, wherein the fibrous material is kenaf.

17. The fibrous moldable substrate of claim 13, wherein the fibrous material comprises hemp and kenaf.

18. The fibrous moldable substrate of claim 17, wherein the fibrous material comprises about 50 weight percent hemp and 50 about weight percent kenaf.

19. The fibrous moldable substrate of claim 13, wherein the mat comprises about 25 weight percent hemp, about 25 weight percent kenaf and about 50 weight percent the binder.

20. The fibrous moldable substrate of claim 13, wherein the binder is a thermomelt binder.

21. The fibrous moldable substrate of claim 20, wherein the binder is polypropylene.

22. The fibrous moldable substrate of claim 13, wherein the mat comprises about 24.75 weight percent hemp, about 24.75 weight percent kenaf, about 50 weight percent a polypropylene binder material and about 0.05 weight percent maleic anhydride.

23. The fibrous moldable substrate of claim 13, wherein the mat is subjected to a compression force where its cross-section is reduced.

24. The fibrous moldable substrate of claim 13, wherein the mat experiences insubstantial two-dimensional shrinkage while being subjected to the heat.

25. The fibrous moldable substrate of claim 13, wherein the fibrous material is selected from a group comprising hemp, kenaf, flax and jute.

26. A fibrous moldable substrate comprising:

a mat comprising a fibrous material and a binder;

wherein fibers of the fibrous material are randomly oriented;

wherein the fibrous material and binder is subjected to heat such that only a portion of the binder is wetted to the fibrous material; and

wherein the mat is semipermeable when cooled.

* * * * *