

F. J. RIBBLE.  
Ratchet-Wheel and Pawl-Mechanism for Rotating  
Shafts by Treadle Power.

No. 207,682.

Patented Sept. 3, 1878.

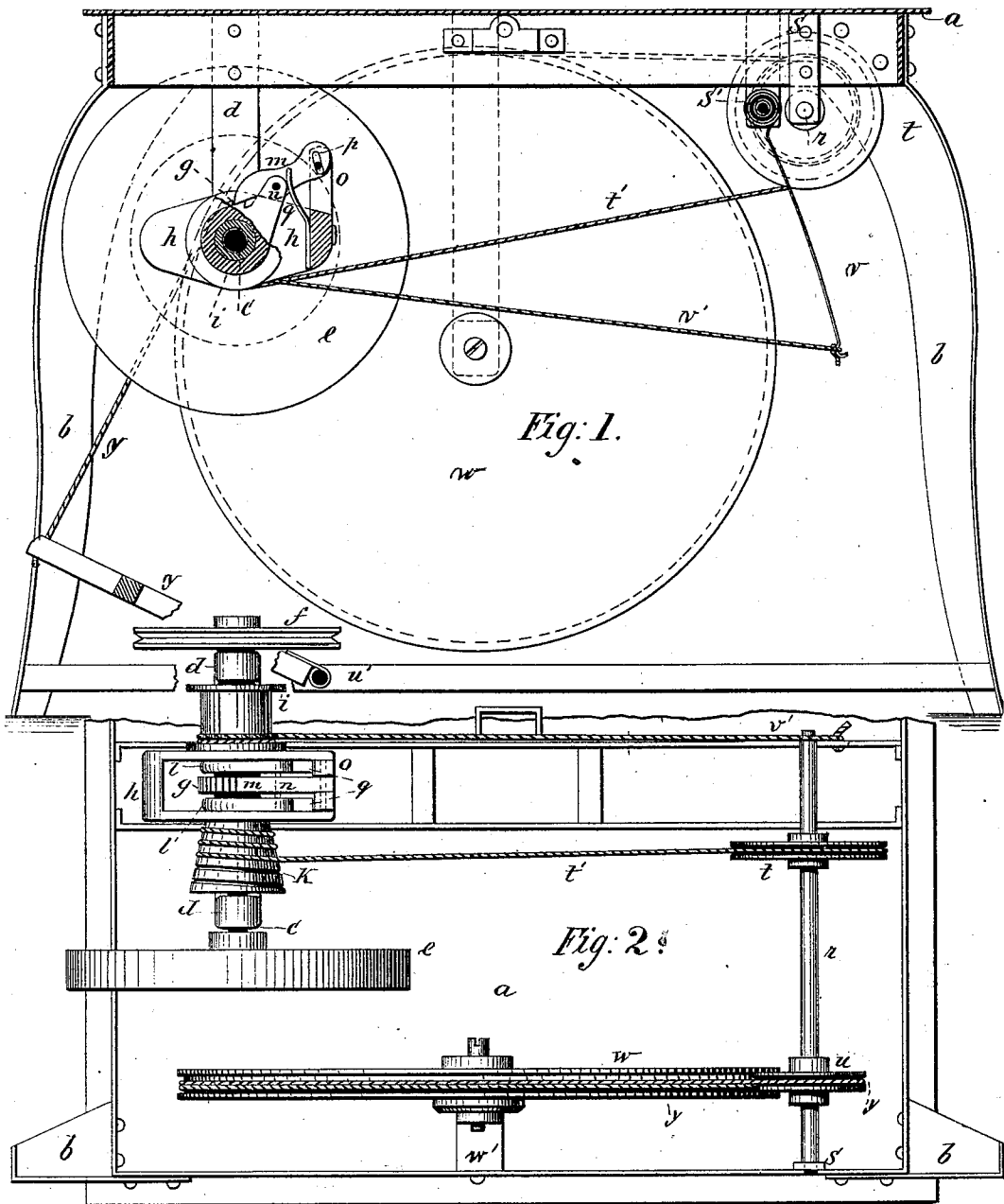

WITNESSES:

*Achilles Schehl.*  
*C. Sedgwick*

*Inventor:*  
*F. J. Ribble*  
BY *Munn & Co.*

ATTORNEYS.

# UNITED STATES PATENT OFFICE.

FRANCIS J. RIBBLE, OF CAMPBELLSPORT, WISCONSIN.

IMPROVEMENT IN RATCHET-WHEEL AND PAWL MECHANISMS FOR ROTATING SHAFTS BY TREADLE-POWER.

Specification forming part of Letters Patent No. 207,682, dated September 3, 1878; application filed June 28, 1878.

*To all whom it may concern:*

Be it known that I, FRANCIS J. RIBBLE, of Campbellsport, in the county of Fond du Lac and State of Wisconsin, have invented a new and Improved Foot-Power Machine, of which the following is a specification:

The object of my invention is to furnish a simple and efficient power which will give a rapid and continuous motion without a crank for driving a circular or scroll saw.

My invention consists in a ratchet-wheel and pawl-carrier upon the driving-shaft, operated by connections from a treadle to cause the pawl to turn the ratchet-wheel and driving-shaft, and then return the pawl to the starting-point. A cord is unwound from a spool to move the pawl and ratchet-wheel by winding the cord upon a wheel propelled by the treadle, and the ratchet is returned by the reaction of a spring acting through a cord on a second spool to return the parts to their normal position.

The pawl is pivoted to arms of the pawl-carrier, and also to arms which are hung loosely upon the shaft of the ratchet-wheel, said pawl being held in contact with the ratchet-wheel by springs bearing upon the loose arms, to which the pawls are pivoted.

In the drawing, Figure 1 is a sectional elevation of my improved foot-power as attached to a table, and Fig. 2 is an inverted plan of the same.

Similar letters of reference indicate corresponding parts.

The table *a*, of wood or iron, is supported by legs *b*. This table *a* is to be of a convenient size and character to fit it for use with a circular or scroll saw, or whatever work it is desired to do with the power. *c* is the driving-shaft, hung in bearings on the hangers *d d*, which are attached to the under side of the table. The shaft *c* has at one end a fly-wheel, *e*, and at the other end the pulley *f*, which pulley *f* may be used to belt from, and it is also provided with a crank-pin for connecting a scroll-saw. *g* is a ratchet-wheel, keyed to the shaft *c* centrally between the wheels *e* and *f*. *h* is a pawl-carrier, loose upon the shaft *c*. *i* and *K* are spools, loose on the shaft *c*, and connected to the pawl-carrier *h*, one at each side thereof, so as to move with it. The spool

*i* is an ordinary flanged spool, while spool *K* is conical, and has upon it a spiral groove. *l l* are arms hung loosely upon the shaft *c*, inside of the pawl-carrier *h*, one at each side of the ratchet-wheel *g*; and *m* is the pawl or dog, pivoted near its center, at *n*, between the arms *l l*. The tail of the pawl *m* passes through slots in the right-angle projection *o* from the end of the carrier *h*, and is loosely connected by a pin passing through *o* and through a slot, *p*, across the end of the pawl. *q q* are flat springs, attached inside the pawl-carrier *h*, and bearing upon the arms *l l*, to cause the pawl *m* to engage with the teeth of *g*. *r* is a secondary shaft, hung in hangers *S S* at the under side of the table *a*, and having keyed upon it the grooved wheels *t* and *u*. *v* is an arm projecting from a spiral spring, *S'*. The shafts *c* and *r* are parallel, the arm *v* is in line with the spool *i*, and there is a cord, *v'*, from the end of *v*, connected to *i*. The grooved wheel *t* is in line with the spool *K*, and a cord, *t'*, connected upon *t*, is attached to the small end of *K*, and wound in the spiral groove on its surface. *w* is a wheel of large diameter, hung upon the hanger *w'*, at the under side of the table *a*, in line with the wheel *u*; and *y* is a cord passing from wheel *u* once around the wheel *w*, and connected to the moving end of a treadle, *y*, which is pivoted at *w'* on the frame of the table *a*. The periphery of the wheel *w* is grooved to retain the cord *y* in place.

When the machine is at rest the position of the above-described parts is as shown in the drawing. The pedal is raised; the cord *y'* is wound around wheel *w* and once around wheel *u*; the cord *t'* is wound upon the conical spool *K*, and connected at its end in the groove of wheel *t*; the cord *v'* is wound one or more turns around spool *i*, in the opposite direction to that which the cord *t'* is wound on spool *K*, and the arm *v* and spring *S'* are free from tension.

If the treadle be depressed, the cord *y* is drawn upon, which revolves the large wheel *w*, and unwinds the cord *y'* from *u*; the shaft *r* and wheel *t* are thereby revolved, and the cord *t'* wound upon *t*, which unwinds it from *K*. The diameter of *t* should be large enough to cause the cord *t'* to be almost entirely unwound from *K* by the downward movement of the

treadle *y'*. The cord *t'*, in unwinding from spool K, revolves it, and spool *i* and the pawl-carrier *h*, and causes the pawl *m* to engage with the ratchet-wheel *g*, and thereby turn the shaft *c*, driving-pulley *f*, and fly-wheel *e*, to propel the saw or other device connected with *f*. The cord *v'* is at the same time wound upon *i*, drawing the arm *v* forward and winding the spring S. As soon as the treadle reaches its extreme downward movement it is relieved from pressure, and the spring S will then return the arm *v* to its normal position, unwinding the cord *v'* from spool *i*, which returns the ratchet to its first position, the pawl passing over the teeth without effect. This movement also rewinds the cord *t'* upon K, thereby unwinding it from wheel *t*, which reverses the motion of the shaft *r* and wheels *u* and *w*, and raises the treadle.

The fly-wheel *e*, by its momentum, continues the motion of the shaft *c* in the direction it is first started, and the treadle may be again operated as before, so as to impart a rapid and continuous revolution to the shaft *c*.

There is no dead-center to be overcome in this machine; and by the use of the cone pulley or spool, I obtain high speed when the machine is first started, and the speed gradually increases as the cord is unwound from the cone.

The manner shown of connecting the pawl to the carrier *h* causes the pawl to act instantly the treadle is depressed, and relieves the pawl on its return movement, so as to avoid friction.

I do not limit myself to the size or character of the wheels and other parts described, as they may be varied without departing from my invention.

Having thus described my invention, I claim as new and desire to secure by Letters Patent—

1. The ratchet-wheel *g*, pawl-carrier *h*, pawl *m*, spools *i* and K, wheel or crank *f*, and fly-wheel *e*, arranged substantially as described upon the main shaft *c*, in combination with the grooved wheels *t* and *u*, spring-arm *v*, wheel *w*, treadle *y*, and cords *t'* *v'* *y'*, substantially as and for the purposes set forth.

2. The pawl-carrier *h*, spools *i* K, and pawl *m*, in combination with the ratchet-wheel, substantially as described, and for the purposes set forth.

3. The combination of the pivoted pawl *m*, the pawl-carrier *h*, the pivoted arms *l*, and the springs *q* with the shaft and ratchet-wheel, as and for the purpose set forth.

FRANCIS JAMES RIBBLE.

Witnesses:

J. H. DILL,  
P. J. HAHN.