



- (51) **International Patent Classification:**
A24D 3/04 (2006.01) *A24D 3/14* (2006.01)
- (21) **International Application Number:**
PCT/IB2008/001758
- (22) **International Filing Date:**
15 April 2008 (15.04.2008)
- (25) **Filing Language:** English
- (26) **Publication Language:** English
- (71) **Applicant (for all designated States except US):** PT HANJAYA MANDALA SAMPOERNA TBK. [ID/ID]; JI Rungkut Industri Raya No.18, Surabaya 60293 (ID).
- (72) **Inventors; and**
- (75) **Inventors/Applicants (for US only):** PANJAITAN, Daniel; JI Kayujati IV/27, Rawamangun, Jakarta timur 13220 (ID). SURYANEGARA, Imam, Taufik; JI Dahlia No. 6, RT06/RW01, Lanudal Juanda, Sedati-sidoarjo 61253 (ID).
- (81) **Designated States (unless otherwise indicated, for every kind of national protection available):** AE, AG, AL, AM,

AO, AT, AU, AZ, BA, BB, BG, BH, BR, BW, BY, BZ, CA, CH, CN, CO, CR, CU, CZ, DE, DK, DM, DO, DZ, EC, EE, EG, ES, FI, GB, GD, GE, GH, GM, GT, HN, HR, HU, ID, IL, IN, IS, JP, KE, KG, KM, KN, KP, KR, KZ, LA, LC, LK, LR, LS, LT, LU, LY, MA, MD, ME, MG, MK, MN, MW, MX, MY, MZ, NA, NG, NI, NO, NZ, OM, PG, PH, PL, PT, RO, RS, RU, SC, SD, SE, SG, SK, SL, SM, SV, SY, TJ, TM, TN, TR, TT, TZ, UA, UG, US, UZ, VC, VN, ZA, ZM, ZW.

- (84) **Designated States (unless otherwise indicated, for every kind of regional protection available):** ARIPO (BW, GH, GM, KE, LS, MW, MZ, NA, SD, SL, SZ, TZ, UG, ZM, ZW), Eurasian (AM, AZ, BY, KG, KZ, MD, RU, TJ, TM), European (AT, BE, BG, CH, CY, CZ, DE, DK, EE, ES, FI, FR, GB, GR, HR, HU, IE, IS, IT, LT, LU, LV, MC, MT, NL, NO, PL, PT, RO, SE, SI, SK, TR), OAPI (BF, BJ, CF, CG, CI, CM, GA, GN, GQ, GW, ML, MR, NE, SN, TD, TG).

Published:

— with international search report (Art. 21(3))

- (54) **Title:** FILTER FOR A SMOKING ARTICLE

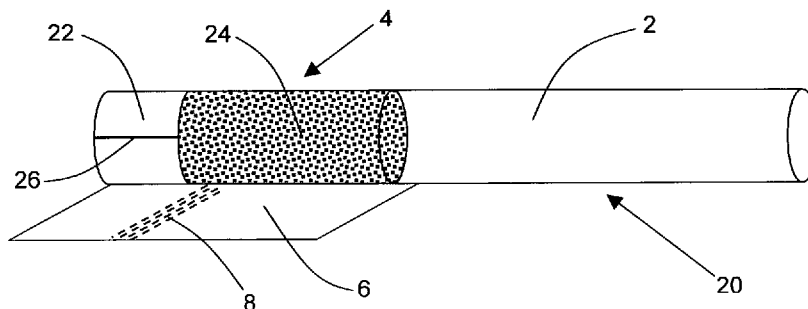

Figure 2

- (57) **Abstract:** A filter (4) for a smoking article has a clove segment (14)(24) comprising clove particles. The filter (4) preferably comprises a mouth end segment (22) downstream of the clove segment (24). The filter (4) may also comprise a rod end segment (32) comprising filtration material upstream of the clove segment (24). Preferably, one or both of the mouth end segment (22) and the rod end segment (32) comprises at least one liquid flavourant. The rod end segment (32) may include a sorbent.

WO 2009/127894 A1

FILTER FOR A SMOKING ARTICLE

The present invention relates to a filter for a smoking article and to a smoking article comprising such a filter.

Filter cigarettes typically comprise a rod of tobacco cut filler surrounded by a paper wrapper and a cylindrical filter aligned in an end-to-end relationship with the wrapped tobacco rod and attached thereto by tipping paper. Ventilation in the form of circumferential perforations is commonly provided at a location along the filter, to mix the mainstream smoke produced during combustion of the wrapped tobacco rod with ambient air.

To enhance the flavour of the mainstream smoke, it is known to provide filter cigarettes that include flavourants. In particular, it is known to provide filter cigarettes in which one or more flavourants are mixed with the tobacco in the tobacco rod in order to provide additional flavour to the mainstream smoke as the tobacco is burnt. For example, cigarettes in which clove particles are mixed with the cut tobacco and a casing in the tobacco rod are popular in certain countries, such as Indonesia. Such cigarettes are known as "kretek" cigarettes. As the cloves in kretek cigarettes are burnt, their flavour and aroma is released into the mainstream smoke. However, the burning of the cloves can result in the generation of sparks, which may be undesirable for the consumer.

It would be desirable to provide a filter for a smoking article that, in use, provides improved clove flavour delivery to the mainstream smoke as it is drawn from a rod of smokable material through the filter.

According to the present invention there is provided a filter for a smoking article including a clove segment comprising clove particles.

The term "clove" is used to denote the dried, unopened flower buds of the clove tree (*Syzygium aromaticum*), commonly used as a spice. The clove particles in the filter of the present invention may include whole cloves. Alternatively, or in addition, the clove particles may comprise ground or crushed cloves, or cloves that have been otherwise processed to reduce the particle size.

According to the invention there is also provided a smoking article comprising a wrapped rod of smokable material and a filter according to the present invention attached to the rod of smokable material, preferably by tipping paper. Preferably, the smoking article is a filter cigarette.

If desired, smoking articles according to the present invention may comprise a rod of smokable material including clove particles.

As the mainstream smoke is drawn through the filter during smoking, flavour compounds, such as oils, from the clove particles are volatilised. The mainstream smoke

enriched with the volatile oils from the clove particles flows downstream through the clove segment into the consumer's mouth.

The clove flavours provided during smoking are similar to those provided during smoking of a kretek cigarette. The taste of a kretek cigarette can therefore be simulated using filters according to the present invention, without the need to provide clove particles in the tobacco rod. Unlike in a kretek cigarette, the clove particles in filters according to the present invention are not burnt during smoking and therefore the problems associated with the burning of the cloves, as discussed above, are substantially eliminated.

Filters according to the present invention may consist of the clove segment alone. However, in particularly preferred embodiments of the present invention, the filter is a multi-component filter having a clove segment comprising clove particles, and one or more additional segments. The additional one or more segments may be provided upstream, or downstream, or both upstream and downstream of the clove segment.

Throughout the specification, the terms "upstream" and "downstream" are used to describe the relative positions of segments of multi-component filters of the invention in relation to the direction of the mainstream smoke drawn from a rod of smokable material through the multi-component filter during use. For example, in a multi-component filter of the present invention in which an additional mouth end segment is provided downstream of the clove segment, the mainstream smoke is drawn first through the clove segment and then through the mouth end segment.

In a first aspect of the present invention, the clove particles in the clove segment are distributed through a plug of fibrous filtration material, such as cellulose acetate tow or paper. A filter plasticiser may be applied to the fibrous filtration material in a conventional manner, by spraying it onto the separated fibres, preferably before applying the clove particles to the filtration material.

Preferably, the clove particles are substantially evenly distributed along the length the plug of fibrous filtration material.

Preferably, filters according to the first aspect of the present invention further comprise a mouth end segment downstream of the clove segment. The mouth end segment may comprise a hollow tube or recess. The hollow tube or recess may be formed when the multi-component filter is attached to a rod of smokable material by, for example, tipping paper to form a smoking article according to the present invention. Where the mouth end segment comprises a hollow tube or recess, the length of the mouth end segment is preferably between about 3 mm and about 4 mm.

In a second aspect of the invention, the clove segment comprises a cavity at least partially filled with clove particles. The cavity is provided between a mouth end segment and a

rod end segment. Preferably, between 40% and 100% of the volume of the cavity is filled with clove particles, more preferably between 60% and 80% of the volume of the cavity. The size of the clove particles within the cavity may vary according to the filled volume of the cavity but is preferably between about 0.1 mm and 2.5 mm. Most preferably, the clove particles are between 0.4 mm and 0.8 mm in size. Cavity filters according to the second aspect of the invention may be produced using known machinery for producing charcoal filters, such as that described in EP-A-1,571,933. Such machinery is available from Filtrona International Ltd., Great Britain.

In filters according to the second aspect of the invention, the clove segment is preferably between about 2 mm and about 12 mm in length, more preferably between 3 mm and 8 mm and most preferably between 4 mm to 6 mm.

In a third aspect of the invention, the clove segment comprises a plug of tobacco leaf through which the clove particles have been distributed. The tobacco leaf may be shredded, cut, or otherwise reduced in size. Preferably, the tobacco leaf has a cut width of between 0.3 mm and 1.2 mm, most preferably between 0.6 mm and 0.9 mm

Preferably the tobacco leaf in the clove segment is dried. Preferably the moisture content of the tobacco leaf is about 15% or less by weight.

The clove segment may include tobacco leaf to which casing comprising, for example, sugars or humectants has been applied.

In a fourth aspect of the invention, the clove segment comprises reconstituted sheet comprising clove particles. The reconstituted sheet may be made completely of clove particles. Alternatively the reconstituted sheet may be, for example, a reconstituted sheet of tobacco with clove particles distributed therein. The reconstituted sheet is preferably shredded, cut or otherwise reduced in size. Preferably, the reconstituted sheet has a cut width of between 0.15 mm and 1.5 mm, more preferably between 0.3 mm and 1.0 mm and most preferably between 0.5 mm and 0.8 mm.

In a fifth aspect of the invention, filters according to the present invention further comprise a flavour release segment. The inclusion of a flavour release segment further enhances flavour delivery to the consumer during smoking.

Preferably, the flavour release segment comprises tobacco leaf. The tobacco leaf may be shredded, cut, or otherwise reduced in size. Preferably, the tobacco leaf has a cut width of between about 0.3 mm and 1.2 mm, most preferably between about 0.6 mm and 0.9 mm.

Preferably the tobacco leaf in the flavour release segment is dried. Preferably the moisture content of the tobacco leaf is about 15% or less by weight.

Preferably, the length of the flavour release segment is between about 6 mm and about 12 mm, more preferably between about 6 mm and about 10 mm.

The flavour release segment may include tobacco leaf to which casing comprising, for example, sugars or humectants has been applied.

The clove segment of filters according to the present invention may further comprise plant leaf in addition to the clove particles. The term "plant leaf" is used to denote a material consisting of the leaves of a plant, which have preferably been cut or shredded to provide a particulate material. The plant leaf may be tobacco leaf, or non-tobacco plant leaf. The clove segment may include leaf from one or more plants. Preferably, the plant leaf is shredded, cut or otherwise reduced in size. More preferably, the plant leaf has a cut width of between about 0.25 mm and about 3 mm, most preferably between about 1 mm and about 2 mm. Preferably, the plant leaf is dried to a moisture content of between about 8 % and about 10 %.

If the plant leaf is non-tobacco plant leaf, preferably the plant leaf is herb leaf from herbaceous plants including, but not limited to, peppermint, lemon balm, basil cinnamon, lemon basil, chive, coriander, basil, lavender, sage, tea, thyme and carvi.

In addition or alternatively, the clove segment may comprise particles of a spice other than clove, such as cinnamon or ginger.

Multi-component filters according to the present invention may include a mouth end segment downstream of the clove segment. The mouth end segment may, in some embodiments, advantageously prevent clove particles from the clove segment reaching the mouth of the consumer during smoking. Preferably, the mouth end segment comprises filtration material. More preferably, the mouth end segment comprises filtration material that has substantially no particulate phase filtration efficiency or very low particulate phase filtration efficiency. The mouth end segment may, for example, comprise cellulosic material, such as cellulose acetate tow, or other suitable fibrous filtration material of low filtration efficiency.

Where the mouth end segment comprises filtration material, the length of the mouth end segment is preferably between about 3 mm and about 12 mm, more preferably between about 6 mm and about 8 mm.

Alternatively, or in addition to the mouth end segment, multi-component filters according to the present invention may comprise a rod end segment upstream of the clove segment. Preferably, the rod end segment comprises fibrous filtration material. The rod end segment may, for example, comprise cellulosic material, such as cellulose acetate tow, or other suitable fibrous filtration materials such as paper. The inclusion of a rod end segment comprising filtration material advantageously provides additional filtration efficiency.

Alternatively or in addition, the rod end segment may comprise at least one sorbent capable of removing at least one gas phase constituent from mainstream smoke drawn through the filter. Preferably, the at least one sorbent is selected from the group consisting of activated carbon, active aluminium, zeolites, sepiolites, molecular sieves and silica gel.

The rod end segment may include one or more flavourants, preferably one or more liquid flavourants, to further enhance flavour delivery to the consumer during smoking.

For example, the rod end segment may comprise a plug of filtration material including one or more threads impregnated with liquid flavourant. The one or more threads may be made from cellulose acetate yarn, rayon, cotton, or any other hydrophilic textile or non-textile material capable of absorbing or adsorbing the liquid flavourant. The threads may be coloured, for example, to indicate the type of flavourant impregnated therein. If more than one thread is provided, the threads may be the same or different colours and may be impregnated with the same or different liquid flavourants. Preferably, the threads are between about 0.6 mm and about 2.0 mm in diameter, more preferably about 0.8 mm in diameter. Filter plugs comprising flavourant bearing threads suitable for use in rod end segments of multi-component filters according to the present invention, and methods and apparatuses for producing such plugs, are described in US Patents Nos. 4,281,671 and 7,074,170 and are available from the American Filtrona Company, Richmond, Virginia, USA.

Alternatively, the rod end segment may include a plurality of beads impregnated with liquid flavourant. The beads may be formed from, for example, a cellulosic material bonded with a polyvinyl acetate binder, or from tobacco powder bonded with microcrystalline cellulose. Beads suitable for use in rod end segments of multi-component filters according to the present invention are manufactured and sold under the brand Viscopearls® by Rengo Co. Ltd., Japan. Methods and apparatuses for producing such beads are also described in Japanese Patent Application No. 10182842. The beads may be of the same or different diameters and colours. The colour of the beads may, for example, indicate the type of flavourant with which they are impregnated. Preferably, the beads are between about 0.2 mm and about 2 mm in diameter.

Liquid flavourants for use in the rod end segments of multi-component filters according to the present invention may include one or more flavour ingredients to create a certain flavour type and may be natural extracts, synthetic flavours, or a combination thereof. Liquid flavourants and flavour types that may be included in the rod end segment of multi-component filters according to the present invention include, but are not limited to, menthol, peppermint, spearmint, coffee, tea, spices (such as cinnamon, clove and ginger), cocoa, vanilla and fruit flavourants. In preferred embodiments of the present invention the rod end segment of the multi-component filter preferably comprises a liquid clove flavourant.

The mouth end segment may comprise at least one flavourant, such as those previously described above for the rod end segment. Preferably, if a flavourant is provided, the mouth end segment includes one or more threads impregnated with liquid flavourant.

Multi-component filters according to the present invention may include mouth end segments comprising at least one flavourant or rod end segments comprising at least one

flavourant or mouth end segments comprising at least one flavourant and rod end segments comprising at least one flavourant. Where the mouth end segment and the rod end segment comprise at least one flavourant, the at least one flavourant in the mouth end segment may be the same as or different to the at least one flavourant in the rod end segment.

In use, as mainstream smoke is drawn from a rod of smokable material through the multi-component filter, flavour is released into the mainstream smoke from the clove particles in the clove segment. In embodiments of the present invention in which at least one flavourant is provided in the rod end segment, flavour is also released upstream of the clove segment as previously described above. In embodiments of the present invention in which at least one flavourant is alternatively or additionally provided in the mouth end segment, flavour is also released downstream of the clove segment. Multi-component filters according to the present invention may, therefore, provide dual or triple flavour enhancement to mainstream smoke drawn through the filter during smoking.

Multi-component filters according to the present invention may be produced by forming separate continuous rods comprising multiple units of each individual segment of the multi-component filter and then combining these separate rods in a known manner in one or more stages to form a continuous filter rod comprising multiple units of the multi-component filter. The continuous filter rod may then be subsequently severed at regular intervals by a cutting mechanism to yield a succession of discrete multi-component filters according to the invention.

Preferably, smoking articles according to the present invention comprise a wrapped rod of tobacco cut filler.

In certain embodiments, the wrapper used to wrap the tobacco rod may be coated with a solution of encapsulated flavours in β -cyclodextrin, which odorises the mainstream smoke during smoking. A suitable example of such a coating is Emanate(s)[®] (available from V. Mane Fils, France) which is a product consisting of a range of β -cyclodextrin inclusion complexes such as Eugenol.

Preferably, smoking articles according to the present invention have a total nicotine free dry particulate matter (NFDPM) or "tar" delivery of up to about 12 mg. More preferably, the "tar delivery" is between 0.1 mg and 10 mg and still more preferably, about 6 mg or less.

Preferably, the overall length of smoking articles according to the present invention is between about 70 mm and about 128 mm, more preferably about 84 mm.

Preferably, the external diameter of filters and smoking articles according to the present invention is between about 5 mm and 8.5 mm, more preferably about 7.9 mm.

Preferably, the overall length of filters according to the present invention is between about 18 mm and about 36 mm, more preferably about 27 mm. Preferably, the length of each

individual segment of multi-component filters according to the present invention is between about 5 mm and about 22 mm.

Smoking articles according to the present invention may be packaged in containers, for example in soft packs or hinge-lid packs, with an inner liner coated with one or more flavourants.

The invention will be further described, by way of example only, with reference to the accompanying drawings, in which:

Figure 1 shows a side view of a filter cigarette comprising a single segment filter according to a first embodiment of the first aspect of the invention.

Figures 2 and 3 show side views of two filter cigarettes comprising multi-component filters according to second and third embodiments, respectively, of the first aspect of the present invention;

Figures 4 to 7 show schematic longitudinal cross sections of four filter cigarettes comprising multi-component filters according to fourth to seventh embodiments, respectively, of the first aspect of the present invention;

Figure 8 shows a side view of a filter cigarette comprising a multi-component filter according to an embodiment of the second aspect of the present invention; and

Figure 9 shows a side view of a filter cigarette comprising a multi-component filter according to an embodiment of the fifth aspect of the present invention.

The filter cigarettes shown in Figures 1 to 9 have several components in common and these components have been given the same reference numerals. In each of the side views, portions have been broken away to illustrate interior details of the filter.

Each filter cigarette generally comprises an elongate, cylindrical wrapped tobacco rod 2 attached at one end to an axially aligned, elongate, cylindrical, filter 4. The wrapped tobacco rod 2 and the filter 4 are joined in a conventional manner by tipping paper 6, which circumscribes the entire length of the filter and an adjacent portion of the wrapped tobacco rod 2. To ventilate mainstream smoke produced during combustion of the wrapped tobacco rod 4 with ambient air, a plurality of annular perforations 8 are provided through the tipping paper 6 at a location along the filter 4.

The filter 4 of the cigarette 10 according to the first embodiment of the invention shown in Figure 1 is a single segment filter consisting of a clove segment 14 adjacent to and abutting the wrapped tobacco rod 2. The clove segment 14 comprises a plug of cellulose acetate tow with particles of ground cloves substantially evenly distributed through it.

The filter 4 of the filter cigarette 20 according to the second embodiment of the invention shown in Figure 2 includes two segments in abutting end-to-end relationship: a mouth end segment 22, distant from the wrapped tobacco rod 2; and a clove segment 24, located

upstream of the mouth end segment 22 and adjacent to and abutting the wrapped tobacco rod 2. The mouth end segment 22 comprises a plug of cellulose acetate tow of low filtration efficiency plasticised with glycerol triacetate. The clove segment 24 comprises a plug of cellulose acetate tow with particles of ground cloves substantially evenly distributed through it. The mouth end segment 12 of the filter cigarette 20 further comprises a central cotton thread 26 loaded with clove oil that extends axially through the plug of cellulose acetate tow, parallel to the longitudinal axis of the filter cigarette 20. In alternative embodiments, this thread may be absent.

In an alternative embodiment of the present invention (not shown), the mouth end segment 22 of the multi-component filter 4 shown in Figure 2 is replaced by a recess, which has substantially no filtration efficiency, formed by the tipping paper 6.

The filter cigarette 30 shown in Figure 3 has a multi-component filter 4 that includes three segments in abutting end-to-end relationship: a mouth end segment 22, distant from the tobacco rod 2; a clove segment 24 located upstream of the mouth end segment; and a rod end segment 32, located upstream of the clove segment 24 and adjacent to and abutting the wrapped tobacco rod 2. The mouth end segment 22 and the clove segment 24 are of the same construction as those previously described for the filter cigarette 20 shown in Figure 2.

The rod end segment 32 comprises a plug of cellulose acetate tow of medium to high filtration efficiency which, in use, partially filters out particulate phase components of the mainstream smoke.

The multi-component filter 4 of the filter cigarette 40 shown in Figure 4 is of similar construction to the multi-component filter 4 of the filter cigarette 30 shown in Figure 3 and described above. However, the mouth end segment 22 of the filter cigarette 40 shown in Figure 4 further comprises a central cotton thread 26 loaded with clove oil that extends axially through the plug of cellulose acetate tow, parallel to the longitudinal axis of the filter cigarette 40.

The multi-component filter 4 of the filter cigarette 50 shown in Figure 5 is also of similar construction to the multi-component filter 4 of the filter cigarette 30 shown in Figure 3 and described above. However, the rod end segment 32 of the multi-component filter 4 of the filter cigarette 50 shown in Figure 5 comprises a central cotton thread 52 loaded with clove oil that extends axially through the plug of cellulose acetate tow, parallel to the longitudinal axis of the filter cigarette 50.

The multi-component filter 4 of the filter cigarette 60 shown in Figure 6 is once again of similar construction to the multi-component filter 4 of the filter cigarette 30 shown in Figure 3 and described above. However, both the rod end segment 32 and the mouth end segment 22 of the multi-component filter 4 of the filter cigarette 60 shown in Figure 6 comprise a central

cotton thread 26, 52 loaded with clove oil that extends axially through the plug of cellulose acetate tow, parallel to the longitudinal axis of the filter cigarette 60.

In alternative embodiments of the present invention (not shown), the rod end segments 32 of the multi-component filters of the filter cigarettes, 40, 50, 60 shown in Figures 4, 5 and 6 may further comprise at least one sorbent capable of removing gas phase constituents from mainstream smoke drawn through the filters 4. The at least one sorbent is, for example, activated carbon, activated aluminium, zeolites or sepiolites provided on the cellulose acetate tow.

The multi-component filter 4 of the filter cigarette 70 shown in Figure 7 is of similar construction to the multi-component filter 4 of the filter cigarette 50 shown in Figure 5 and described above. However, the rod end segment 32 of the multi-component filter 4 of the filter cigarette 70 shown in Figure 7 comprises a plurality of Viscopearls® loaded with menthol, in place of the central cotton thread 52.

In alternative embodiments of the present invention (not shown), the mouth end segments 22 of the multi-component filters 4 of the filter cigarettes 30, 40, 50, 60, 70 shown in Figures 3 to 7 is replaced by a recess, which has substantially no filtration efficiency, formed by the tipping paper 6.

The filter cigarette 80 shown in Figure 8 has a multi-component filter 4 similar in construction to the multi-component filters 4 of the filter cigarettes 30, 40, 50, 60 shown in Figures 3 to 6, which includes three segments in abutting end-to-end relationship: a mouth end segment 22, distant from the tobacco rod 2; a clove segment 24 located upstream of the mouth end segment; and a rod end segment 32, located upstream of the clove segment 24 and adjacent to and abutting the wrapped tobacco rod 2. The mouth end segment 22 and the rod end segment 24 are of the same construction as those previously described for the filter cigarettes 30, 40, 50, 60 shown in Figures 3 to 6. The clove segment 24 comprises a cavity containing particles of ground clove.

It will be appreciated that either or both of the mouth end segment 22 and the rod end segment 42 of the filter cigarette 80 shown in Figure 8 may include a flavourant, as previously described above for the filter cigarettes 30, 40, 50, 60 shown in Figures 3 to 6.

The filter cigarette 90 shown in Figure 9 has a multi-component filter 4 that includes four segments in abutting end-to-end relationship: a mouth end segment 22, distant from the tobacco rod 2; a clove segment 24 located upstream of the mouth end segment, a flavour release segment 92 located upstream of the clove segment; and a rod end segment 32, located upstream of the flavour release segment 92 and adjacent to and abutting the wrapped tobacco rod 2. The mouth end segment 22, the clove segment 24 and the rod end segment 32 are of the same construction as the mouth end segment, the clove segment and the rod end segment

previously described for the filter cigarettes 30, 40, 50, 60, 70 shown in Figures 3 to 7. The flavour release segment 92 comprises a plug of densely packed fine cut tobacco.

To form the filter cigarettes 10, 20, 30, 40, 50, 60, 70, 80, 90 according to the embodiments of the present invention shown in Figures 1 to 9, the filters 4 are produced and then joined to the wrapped tobacco rods 2, which are produced in a conventional manner, by the tipping paper 6 using known filter cigarette making equipment.

To produce the multi-component filters 4 of the filter cigarettes 20, 30, 40, 50, 60, 70, 80, 90 shown in Figures 2 to 9, separate continuous rods comprising multiple units of each segment 22, 24, 32, 92 of the multi-component filter 4 are produced in a known manner and then combined to form a continuous filter rod comprising multiple units of the multi-component filter 4. The continuous filter rod is then severed at regular intervals by a cutting mechanism to yield a succession of discrete multi-component filters.

CLAIMS:

1. A filter (4) for a smoking article having a clove segment (14)(24) comprising clove particles.
2. A filter (4) according to claim 1 wherein the clove segment (14)(24) comprises a plug of cellulose acetate tow with clove particles distributed therein.
3. A filter (4) according to claim 1 or 2 wherein the clove segment (14)(24) further comprises plant leaf.
4. A filter (4) according to claim 3 wherein the clove segment (14)(24) comprises a plug of cut tobacco leaf with clove particles distributed therein.
5. A filter (4) according to claim 1 wherein the clove segment (14)(24) comprises reconstituted sheet comprising clove particles.
6. A filter (4) according to any preceding claim further comprising at least one of: a mouth end segment (22) downstream of the clove segment (24) and a rod end segment (32) upstream of the clove segment (14).
7. A filter (4) according to claim 6 comprising a rod end segment (32) upstream of the clove segment (24) and a mouth end segment (22) downstream thereof, wherein the clove segment (24) comprises a cavity defined between the mouth end segment (22) and the rod end segment (32), at least partially filled with clove particles.
8. A filter (4) according to any preceding claim further comprising a flavour release segment (92) between the mouth end segment (22) and the clove segment (24).
9. A smoking article (10)(20)(30)(40)(50)(60)(70)(80)(90) comprising:
a wrapped rod of smokable material (2); and
a filter (4) according to any preceding claim attached to the rod of smokable material (2) by tipping paper (6).

10. A smoking article (10)(20)(30)(40)(50)(60)(70)(80) according to claim 9 wherein the filter comprises a mouth end segment (22) and wherein the mouth end segment (22) is a hollow tube or recess.

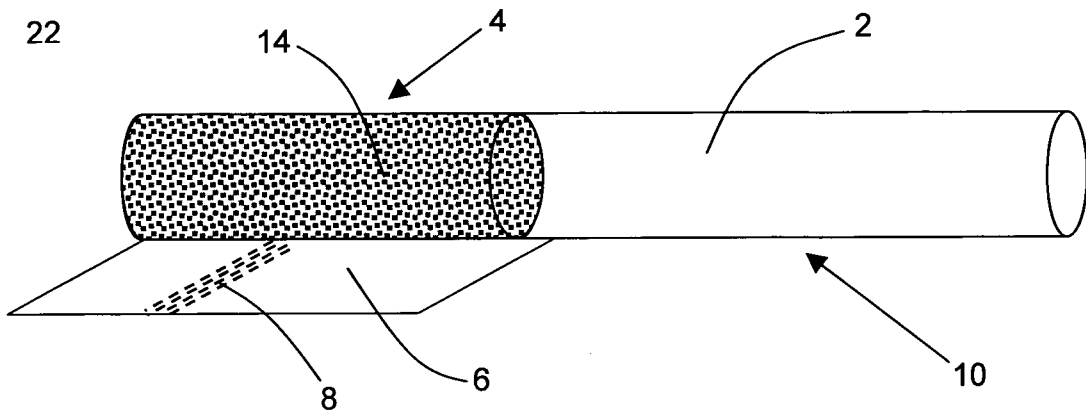

Figure 1

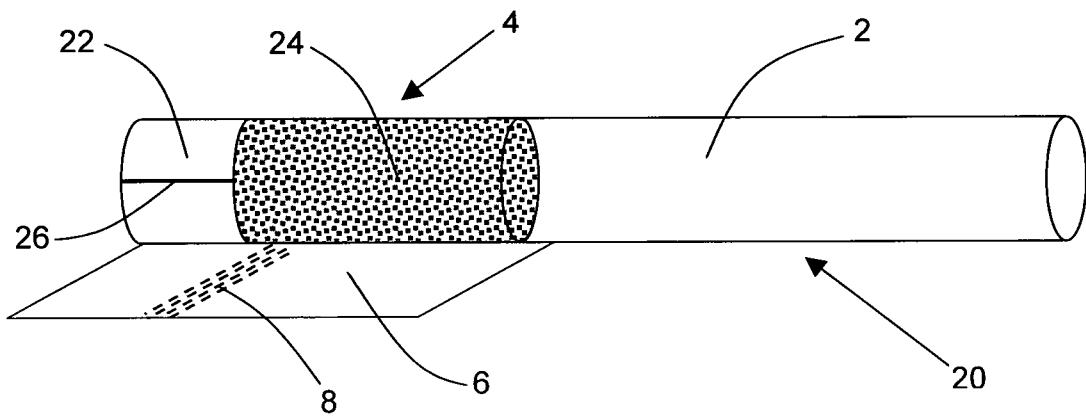

Figure 2

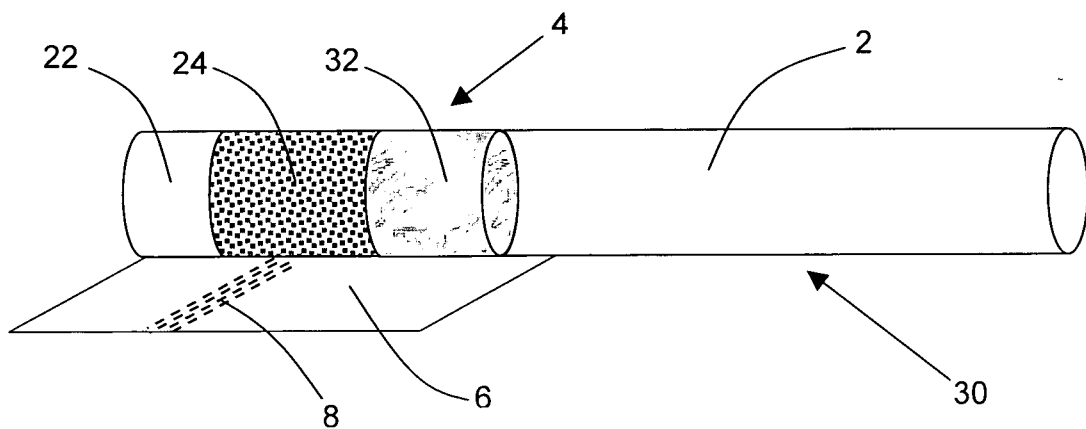

Figure 3

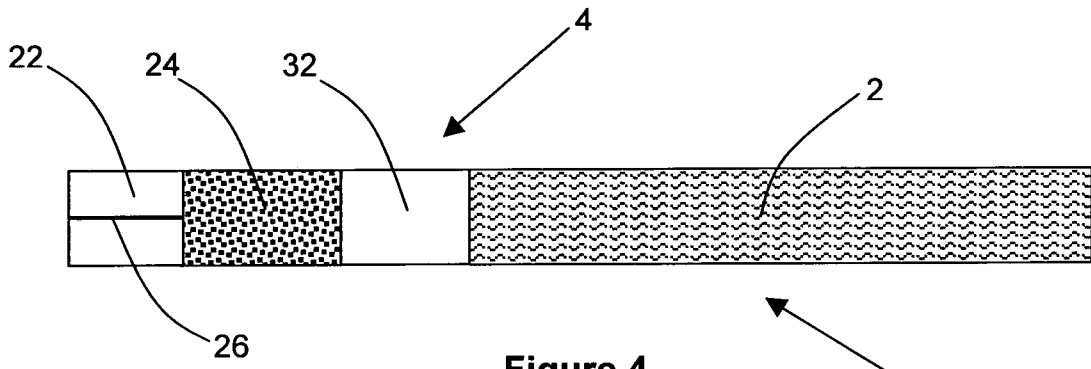

Figure 4

40

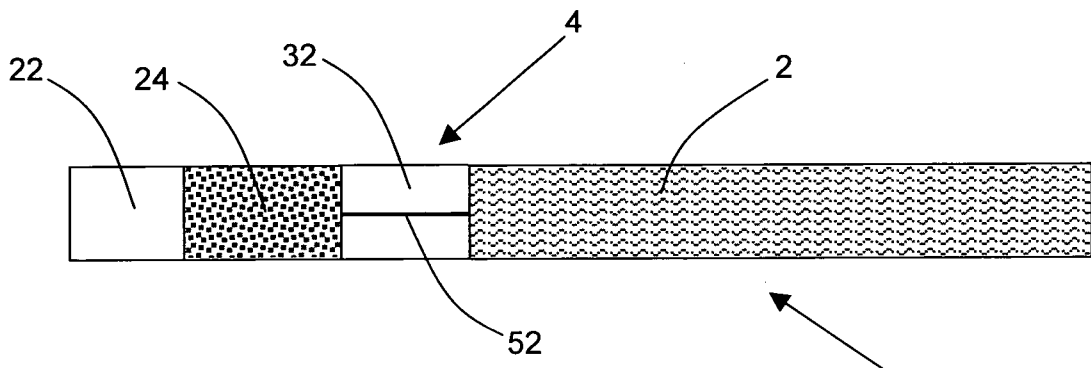

Figure 5

50

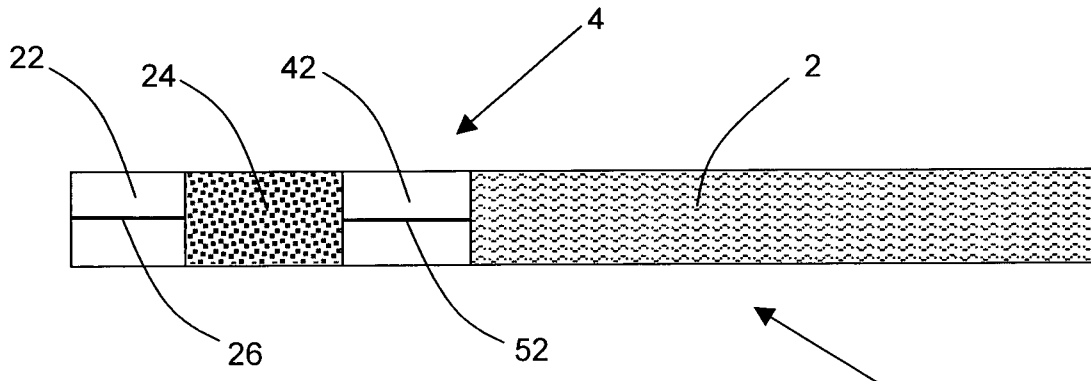
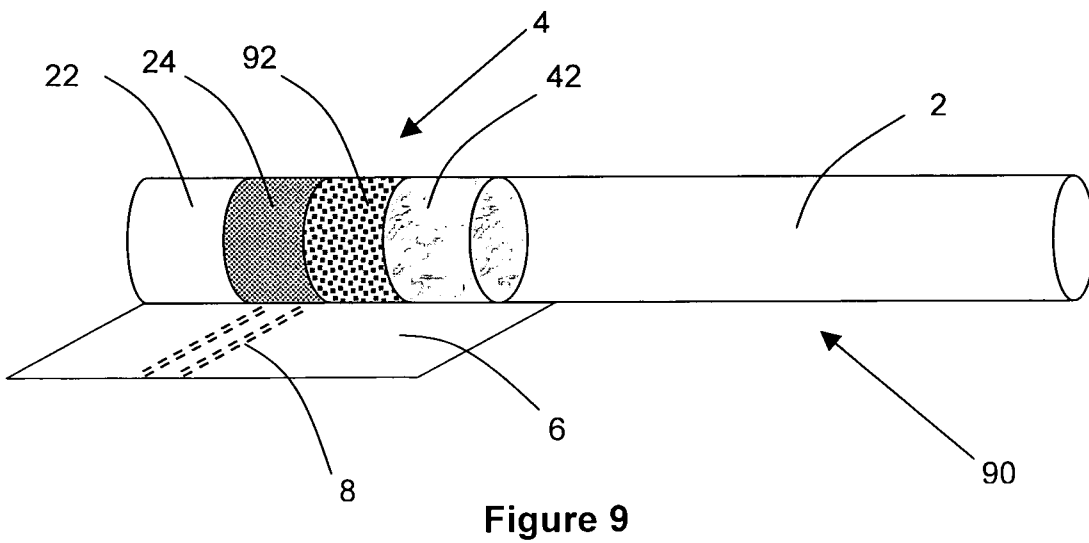
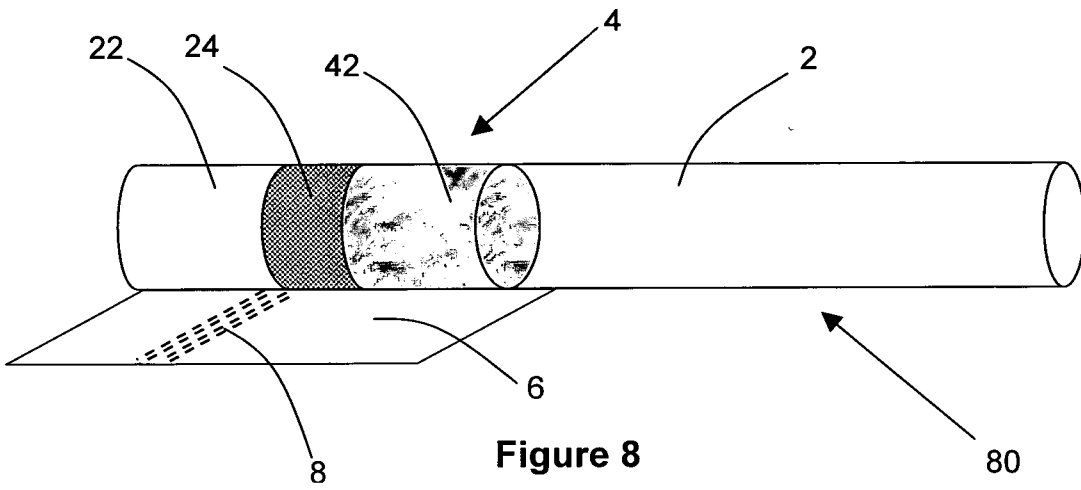
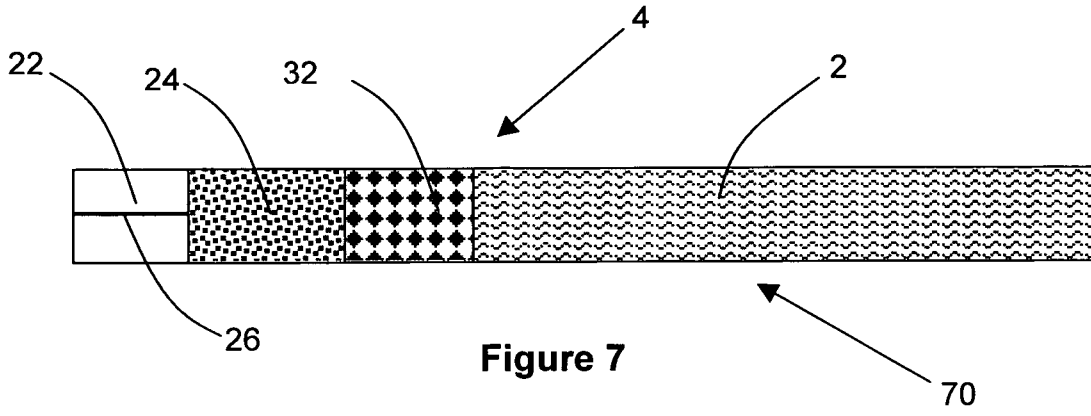

Figure 6

60



INTERNATIONAL SEARCH REPORT

International application No
PCT/IB2008/001758

A. CLASSIFICATION OF SUBJECT MATTER
INV. A24D3/04 A24D3/14

According to International Patent Classification (IPC) or to both national classification and IPC

B. FIELDS SEARCHED

Minimum documentation searched (classification system followed by classification symbols):
A24D

Documentation searched other than minimum documentation to the extent that such documents are included in the fields searched

Electronic data base consulted during the international search (name of data base and, where practical, search terms used)

EPO-Internal

C. DOCUMENTS CONSIDERED TO BE RELEVANT

Category*	Citation of document, with indication, where appropriate, of the relevant passages	Relevant to claim No.
X	EP 1 889 550 A (PHILIP MORRIS PROD [CH]) 20 February 2008 (2008-02-20) paragraph [0016] - paragraph [0069]; figures -----	1-10
X	EP 0 292 949 A (JAPAN TOBACCO INC [JP]) 30 November 1988 (1988-11-30) column 2, line 49 - column 3, line 1; figures -----	1,6,7,9
X	EP 1 905 318 A (REYNOLDS TOBACCO CO R [US]) 2 April 2008 (2008-04-02) paragraph [0063] - paragraph [0071]; figures ----- -/--	1,6,9

Further documents are listed in the continuation of Box C.

See patent family annex.

* Special categories of cited documents :

- *A* document defining the general state of the art which is not considered to be of particular relevance
- *E* earlier document but published on or after the international filing date
- *L* document which may throw doubts on priority claim(s) or which is cited to establish the publication date of another citation or other special reason (as specified)
- *O* document referring to an oral disclosure, use, exhibition or other means
- *P* document published prior to the international filing date but later than the priority date claimed

- *T* later document published after the international filing date or priority date and not in conflict with the application but cited to understand the principle or theory underlying the invention
- *X* document of particular relevance; the claimed invention cannot be considered novel or cannot be considered to involve an inventive step when the document is taken alone
- *Y* document of particular relevance; the claimed invention cannot be considered to involve an inventive step when the document is combined with one or more other such documents, such combination being obvious to a person skilled in the art.
- *&* document member of the same patent family

Date of the actual completion of the international search

27 January 2009

Date of mailing of the international search report

05/02/2009

Name and mailing address of the ISA/
European Patent Office, P.B. 5818 Patentlaan 2
NL - 2280 HV Rijswijk
Tel. (+31-70) 340-2040,
Fax: (+31-70) 340-3016

Authorized officer

Marzano Monterosso

INTERNATIONAL SEARCH REPORT

International application No

PCT/IB2008/001758

C(Continuation). DOCUMENTS CONSIDERED TO BE RELEVANT

Category*	Citation of document, with indication, where appropriate, of the relevant passages	Relevant to claim No.
X	US 2007/074733 A1 (RASOULI FIROOZ [US] ET AL) 5 April 2007 (2007-04-05) paragraph [0069] - paragraph [0073]; figures -----	1,2,9
X	US 2003/168071 A1 (HAN SEUNG HEE [KR]) 11 September 2003 (2003-09-11) paragraph [0032] - paragraph [0036] -----	1,9

INTERNATIONAL SEARCH REPORT

Information on patent family members

International application No

PCT/IB2008/001758

Patent document cited in search report		Publication date	Patent family member(s)	Publication date
EP 1889550	A	20-02-2008	AR 062901 A1	17-12-2008
			BR PI0703419 A	25-03-2008
			EP 1958523 A2	20-08-2008
			WO 2008015570 A2	07-02-2008
			JP 2008035861 A	21-02-2008
			KR 20080012749 A	12-02-2008
			UA 82969 C2	26-05-2008
			US 2008029114 A1	07-02-2008
EP 0292949	A	30-11-1988	DE 3854281 D1	14-09-1995
			DE 3854281 T2	11-01-1996
			GR 3017096 T3	30-11-1995
			HK 96696 A	14-06-1996
			PH 25732 A	18-10-1991
			US 4889144 A	26-12-1989
EP 1905318	A	02-04-2008	EP 1908361 A1	09-04-2008
			EP 1908362 A1	09-04-2008
US 2007074733	A1	05-04-2007	AU 2006313451 A1	18-05-2007
			CA 2623219 A1	18-05-2007
			CN 101277621 A	01-10-2008
			EP 1933654 A2	25-06-2008
			WO 2007054826 A2	18-05-2007
			KR 20080059582 A	30-06-2008
US 2003168071	A1	11-09-2003	CN 1442096 A	17-09-2003
			JP 3718200 B2	16-11-2005
			JP 2003289844 A	14-10-2003
			KR 20030072130 A	13-09-2003