

(19) World Intellectual Property
Organization
International Bureau



(43) International Publication Date
6 October 2005 (06.10.2005)

PCT

(10) International Publication Number
WO 2005/092618 A1

- (51) International Patent Classification⁷: **B41F 27/14**
- (21) International Application Number:
PCT/IB2005/000776
- (22) International Filing Date: 25 March 2005 (25.03.2005)
- (25) Filing Language: English
- (26) Publication Language: English
- (30) Priority Data:
10 2004 015 248.9 29 March 2004 (29.03.2004) DE
- (71) Applicant (for all designated States except US): **GOSS INTERNATIONAL MONTATAIRE SA** [FR/FR]; Square Hippolyte Marinoni, F-60160 MONTATAIRE (FR).
- (72) Inventor; and
- (75) Inventor/Applicant (for US only): **METROPE, Jacques** [FR/FR]; 7 rue François Fernandez, F-60290 LAIGNEVILLE (FR).
- (74) Agents: **DOMENEGO, Bertrand** et al.; Cabinet Lavoix, 2, Place d'Estienne d'Orves, F-75441 Paris Cedex 09 (FR).
- (81) Designated States (unless otherwise indicated, for every kind of national protection available): AE, AG, AL, AM, AT, AU, AZ, BA, BB, BG, BR, BW, BY, BZ, CA, CH, CN, CO, CR, CU, CZ, DE, DK, DM, DZ, EC, EE, EG, ES, FI, GB, GD, GE, GH, GM, HR, HU, ID, IL, IN, IS, JP, KE, KG, KP, KR, KZ, LC, LK, LR, LS, LT, LU, LV, MA, MD, MG, MK, MN, MW, MX, MZ, NA, NI, NO, NZ, OM, PG, PH, PL, PT, RO, RU, SC, SD, SE, SG, SK, SL, SM, SY, TJ, TM, TN, TR, TT, TZ, UA, UG, US, UZ, VC, VN, YU, ZA, ZM, ZW.
- (84) Designated States (unless otherwise indicated, for every kind of regional protection available): ARIPO (BW, GH, GM, KE, LS, MW, MZ, NA, SD, SL, SZ, TZ, UG, ZM, ZW), Eurasian (AM, AZ, BY, KG, KZ, MD, RU, TJ, TM), European (AT, BE, BG, CH, CY, CZ, DE, DK, EE, ES, FI, FR, GB, GR, HU, IE, IS, IT, LT, LU, MC, NL, PL, PT, RO, SE, SI, SK, TR), OAPI (BF, BJ, CF, CG, CI, CM, GA, GN, GQ, GW, ML, MR, NE, SN, TD, TG).
- Published:
— with international search report
- For two-letter codes and other abbreviations, refer to the "Guidance Notes on Codes and Abbreviations" appearing at the beginning of each regular issue of the PCT Gazette.

(54) Title: PACKING SLEEVE FOR A PRINTING UNIT CYLINDER OF AN OFFSET PRINTING PRESS

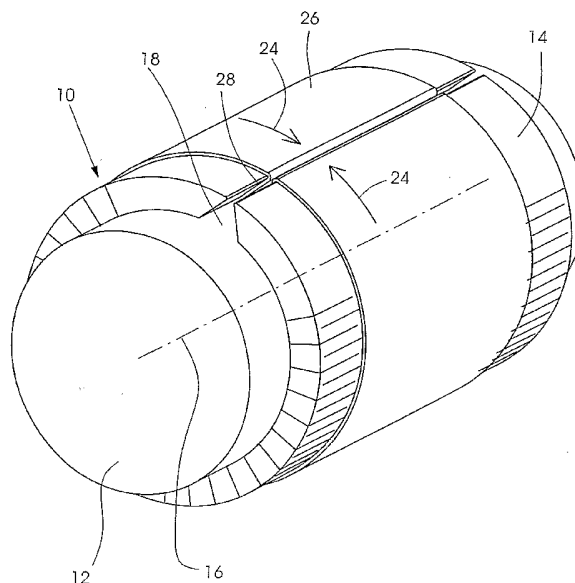

(57) Abstract: A packing sleeve (10) having an outer lateral surface (14) for a printing unit cylinder (12) of an offset printing press is disclosed, wherein the outer lateral surface (14) has at least one region (38) with an area (20) containing a number of incisions (22), which increase the elasticity of the packing sleeve (10) in the peripheral direction (24). The packing sleeve (10) according to the invention can advantageously be used to enlarge the effective outer diameter of a printing unit cylinder (12) in an offset printing press by drawing the packing sleeve (10) over the printing unit cylinder (12) in the offset printing press.

WO 2005/092618 A1

Packing sleeve for a printing unit cylinder of an offset printing press

The invention relates to a packing sleeve having an outer lateral surface for a printing unit cylinder of an offset printing press.

In a printing press, the circumferential length of the printing plate cylinder is a basically limiting parameter for the format or the printing length of products to be produced. In order to achieve flexibility and variability, it is desirable to overcome this limitation to permit a variation in print length or a variation in format. For general geometrical reasons, it is known that the circumferential length of a cylinder, here the printing plate cylinder or rather the transfer cylinder, is proportional to its radius. To vary the circumferential length of a fixed-radius cylinder in a printing press, on which cylinder a printing plate is receivable, sleeve-form packings (packing sleeves) of different thickness can advantageously be mounted on the cylinder. Such sleeves can in specific constructions be seamless or slit. In other words, packing sleeves can be closed tubes or bodies comprising plate-form objects, which have been bent so that remote extreme edges lie opposite one another. With the sleeve mounted, and with a consequently larger radius, the potential or maximum achievable print length is then greater or longer than without the mounted sleeve. The circumferential length of a transfer cylinder or rubber blanket cylinder needed for an offset printing process can also be varied correspondingly. An enlargement of the effective outer diameter of the cylinder, that is, the circumferential length effective in printing mode, can therefore be achieved.

It is known, for example, from the document US 5,813,336, to mount sleeve-form saddles on printing unit cylinders in a printing press, especially printing plate cylinders and transfer cylinders. Plate-form printing plates can be fixed to sleeve-form saddles. In their outer lateral surface the described sleeve-form saddles have an opening that runs substantially parallel to the figure axis, especially the axis of rotational symmetry of the saddle. The leading edge and trailing edges of a printing plate to be received can be inserted in the opening and be fixed with a printing plate

fixing means, not specified in detail. Sleeve-form saddles are provided in different thicknesses (having different outer diameters).

Such packing sleeves have to have a good dimensional stability, for example, they must be able to withstand a compression as a result of cylinders rolling on one another, that is, a force acting in the radial direction. On the other hand, they must be resilient in the peripheral direction (circumferential direction), if a printing plate or a rubber blanket to be received on the outer lateral surface is to be tensioned. At the same time, the surface regions that absorb the tension forces should withstand the pressure generated, so that a comparatively rigid, stiff or low-resilience material is preferred for this in order to avoid wear.

It is an object of the present invention to produce a packing sleeve having anisotropic elasticity properties.

That object is achieved in accordance with the invention by a packing sleeve having the features according to claim 1. Advantageous embodiments of the invention are characterised in the dependent claims.

According to the invention, a packing sleeve, especially of a metallic material, for a printing unit cylinder of an offset printing press, especially a printing plate cylinder or a rubber blanket cylinder, comprises an outer lateral surface having at least one region with an area containing a number of incisions, slits, gaps or elongate openings, which increase the elasticity of the packing sleeve in the peripheral direction. In other words, the number of incisions reduces the dimensional stability in the peripheral direction or circumferential direction. A resilient deformation of the packing sleeve in the peripheral direction becomes possible. In particular, the incisions can have a small width in relation to their length; the incisions can have an orientation. In particular, each web in the area containing of the incisions has a small width, a small average area or a small thickness and is deformable. Very fine incisions can be produced, for example, by means of a laser beam, especially a carbon dioxide laser.

The invention provides a packing sleeve, especially a slit packing sleeve, which has the desired resilient properties for use as an intermediate sleeve for

varying the circumferential length of a printing unit cylinder, whilst at the same time an actually relatively stiff or rigid material can be used. In particular, the material itself may have isotropic elasticity properties. It is clear to the expert that the thickness, gauge, or the outer diameter of the packing sleeve according to the invention remains substantially unchanged upon elongation or strain in the peripheral direction. The packing sleeve according to the invention in this way provides a resilient recovery force in the circumferential direction, corresponding to the force of a linear spring.

It is also immediately obvious to the expert being addressed that the concept according to the invention can be applied to packing sleeves of any convenient material, for example, plastics materials or composite materials. The packing sleeve can preferably consist of steel or aluminium. The packing sleeve can also be called an intermediate sleeve or a saddle: if the printing unit cylinder is a printing plate cylinder, a printing plate is to be received on the packing sleeve, and if the printing unit cylinder is a blanket cylinder, a printing blanket or rubber blanket is to be received on the packing sleeve.

In preferred embodiment, the incisions contained in the area run on the outer lateral surface of the packing sleeve substantially parallel to the figure axis of the packing sleeve, especially to the axis of rotational symmetry of the packing sleeve. In addition, or as an alternative, the incisions in the area can be arranged along lines, incisions of adjacent lines lying offset, preferably regularly offset, with respect to one another. In other words, the area can have a pattern, especially a regular pattern of incisions. Depending on the shaping of the incisions and the ratio of the volume of the material webs around the incisions to the volume of the incisions, the area with a number of incisions can also be referred to as a netlike or honeycomb structure. This area has a macroscopic structuring in material webs and incisions. Preferably, the ratio of the length of the incisions to the spacing of adjacent lines amounts here to a number between 5.00 and 50.00, especially a number between 12.00 and 25.00.

The dilatation, elongation or deformation is dependent on the number of incisions, especially lines along which the incisions are arranged: the larger is this number, the weaker is the deformation of each individual incision.

In one embodiment, a packing sleeve according to the invention can
5 comprise a number of segments that are welded together alternately discontinuously. For example, for a packing sleeve welded together from 21 individual segments, for an elongation of around 0.4 mm, each incision, here the unwelded gap, will have a width of 0.02 mm.

In certain embodiments of the packing sleeve according to the invention, the
10 region can extend substantially over the entire outer lateral surface. Furthermore, it is advantageous if the width of the incisions is sufficiently small that a printing plate to be received on the packing sleeve according to the invention is not deformed by the incisions during printing mode.

In a further development, the packing sleeve according to the invention can
15 have a slot or an opening in the outer lateral surface for receiving edges of a plate-form printing plate or of a printing blanket. Such a slot or such a opening can be in particular trapezoidal or prismatic, a widening being effected from the outer lateral surface towards the inner lateral surface. The slot can be continuous, that is, it can cut through the packing sleeve from the outer lateral surface to the inner lateral
20 surface. In particular, in an advantageous embodiment, in an area surrounding the slot, wherein the surrounding area can be small compared with the overall outer lateral surface of the packing sleeve, the packing sleeve may have no incisions.

Associated with the concept of the invention is also the use of a packing
sleeve, as depicted in this description generally and in various embodiments and
25 developments, for enlarging the effective outer diameter of a printing unit cylinder, especially a printing plate cylinder or a rubber blanket cylinder in an offset printing press, preferably a web-fed rotary offset printing press, by drawing the packing sleeve over the printing plate cylinder in the offset printing press.

Further advantages and advantageous embodiments and developments of the invention are explained with reference to the following Figures and the description thereof. In the Figures:

- 5 Figure 1 shows two states of a plate-form object that can be shaped to form a packing sleeve according to the invention,
- Figure 2 shows an embodiment of a packing sleeve according to the invention on a printing unit cylinder, and
- 10 Figure 3 shows an embodiment of a packing sleeve according to the invention that receives a cylinder packing.

Figure 1 shows two states of a plate-form object 30, especially of steel or aluminium, which can be shaped to form a packing sleeve 10 according to the invention (see Figures 2 and 3). The plate-form object 30 comprises a region 38 with an area 20 of incisions 22. The incisions 22 can be apertures or cut-outs. Preferably, these incisions 22 are continuous, that is to say, the incisions 22 cut through the plate-form object 30, especially in the form of slots or elongate slits.

20 The incisions 22 are arranged along lines, incisions on adjacent lines being arranged offset or alternating with respect to one another. The left-hand side of Figure 1 shows the plate-form object 30 in the resting state 32 or force-free state. In this situation, the plate-form object 30 has a specific dimension and a specific resilient behaviour, which are contingent upon its form and its material. The right-hand side

25 of Figure 1 shows the plate-form object 30 in a second state 34, in which a force 36, a tensile force, acts on the plate-form object 30 with a force component perpendicular to the run of the incisions 22. By virtue of the incisions 22 in the area 20, which have an orientation and hence an anisotropy owing to their shaping, the resilient behaviour of the plate-form object 30 changes, especially anisotropically,

30 compared with an object of corresponding form without incisions. Perpendicular to

the run of the incisions 22, a force 36 causes a dilatation of the plate-form object 30. This deformation or elongation is resilient; on cessation of the force effect, the plate-form object 30 reverts to its resting state 32, as shown on the left-hand side of Figure 1. To cite an example: a packing sleeve according to the invention of 35 mm
5 thick steel, in which alternating incisions of a length of 200 mm are arranged in twenty lines spaced 10 mm apart, can be extended by 0.4 mm with 35 daN per metre of the packing sleeve width (in the direction of the figure axis).

Figure 2 shows an embodiment of a packing sleeve 10 according to the invention on a printing unit cylinder 12. Without loss of generality in respect of the
10 topology and the geometry of a packing sleeve according to the invention, the embodiment shown here is a packing sleeve having slits passing right through it. The packing sleeve 10 has an outer lateral surface 14 and has a figure axis 16, which in the mounted state coincides with the axis of rotation of the printing unit cylinder 12. On the outer lateral surface 14 there is an area 20 containing a number
15 of incisions 22. The incisions 22 are arranged along lines substantially parallel to the figure axis 16. Adjacent lines in the circumferential direction have alternating incisions 22, so that a netlike structure of webs between the incisions 22 is created. The packing sleeve 10 can be tensioned in the peripheral direction 24. A slot 18 serves to receive edges of a cylinder packing (see Figure 3). In the area 19
20 surrounding the slot 18 the packing sleeve has no incisions 22.

For the sake of completeness, it should be mentioned that to change the fixing state of the packing sleeve, especially for mounting or demounting, the printing unit cylinder of this embodiment has a device for tensioning the packing sleeve in the peripheral direction, said device not being more specifically shown
25 here although it is known from the prior art. In the relaxed state, the packing sleeve can be moved relatively easily relative to the printing unit cylinder. As an alternative to this solution, changing of the fixing state, that is, mounting and demounting of the packing sleeve, can be facilitated by stretching the packing sleeve, especially an embodiment of the packing sleeve having an area of incisions that do not cut
30 completely through the packing sleeve from the outer to the inner lateral surface, by

means of compressed air issuing from the printing unit cylinder, so that the packing sleeve is readily displaceable relative to the printing unit cylinder. Such devices are also known from the prior art.

As already mentioned, the packing sleeve according to the invention can be
5 manufactured from a lightweight material, for example aluminium, so that manipulation thereof is simplified. Furthermore, recesses can be present, especially on the inner lateral surface of the packing sleeve, so that the weight of the packing sleeve is reduced, without altering the stiffness.

Figure 3 is a schematic view relating to an embodiment of a packing sleeve
10 10 according to the invention which receives a cylinder packing 26, for example, a printing plate or a printing blanket (rubber blanket). The cylinder packing 26 is held by clamping and stretching the packing sleeve 10 in the peripheral direction 24. The cylinder packing 26 has bent-over edges 28, which engage in the slot 18. The slot 18 widens prism-form from the outer lateral surface 14 inwards towards the figure
15 axis 16. The lateral faces of the slot are thus undercut or angled; the lateral faces and the outer lateral surface enclose an acute angle, so that when a force is effective in the peripheral direction 24, the cylinder packing 26 is stretched in the circumferential direction.

In summary it should again be emphasised that the packing sleeve
20 according to the invention, in particular a metallic packing sleeve, has especially advantageously a resilience adapted in the circumferential direction to the tension forces, whilst the regions of the outer lateral surface that are subjected to load transmission and to wear and tear experience no weakening or reduction in rigidity by virtue of the hardness and the stiffness of the material used, in particular the
25 metal used.

LIST OF REFERENCE NUMERALS

	10	Packing sleeve
	12	Printing unit cylinder
5	14	Outer lateral surface
	16	Figure axis
	18	Slot
	20	Area
	22	Incision
10	24	Peripheral direction
	26	Cylinder packing
	28	Edge
	30	Plate-form object
	32	Resting state
15	34	Second state
	36	Force
	38	Region

CLAIMS

1. A packing sleeve (10) having an outer lateral surface (14) for a printing unit cylinder (12) of an offset printing press, characterised in that the outer lateral surface (14) has at least one region (38) with an area (20) having a number of incisions (22), which increase the elasticity of the packing sleeve (10) in the peripheral direction (24).
2. A packing sleeve (10) according to claim 1, characterised in that the incisions (22) run substantially parallel to the figure axis (16) of the packing sleeve (10).
3. A packing sleeve (10) according to claim 1 or 2, characterised in that the incisions (22) in the area (20) are arranged along lines, incisions (22) of adjacent lines lying offset with respect to one another.
4. A packing sleeve (10) according to claim 3, characterised in that the ratio of the length of the incisions (22) to the spacing of adjacent lines amounts to a number between 5.00 and 50.00.
5. A packing sleeve (10) according to any one of the preceding claims, characterised in that the region (38) extends substantially over the entire outer lateral surface (14).
6. A packing sleeve (10) according to any one of the preceding claims, characterised in that the width of the incisions (22) is sufficiently small that a printing plate to be received on the packing sleeve (10) is not deformed during printing mode.

7. A packing sleeve (10) according to any one of the preceding claims, characterised in that the packing sleeve (10) has a slot (18) in the outer lateral surface (14) for receiving edges (28) of a plate-form printing plate or of a printing blanket.
8. A packing sleeve (10) according to claim 6, characterised in that an area (19) surrounding the slot (18) has no incisions (22).
9. A packing sleeve (10) according to any one of the preceding claims, characterised in that the packing sleeve (10) consists of steel or aluminium.
10. Use of a packing sleeve (10) according to any one of the preceding claims for enlarging the effective outer diameter of a printing unit cylinder (12) in an offset printing press, by drawing the packing sleeve (10) over the printing unit cylinder (12) in the offset printing press.

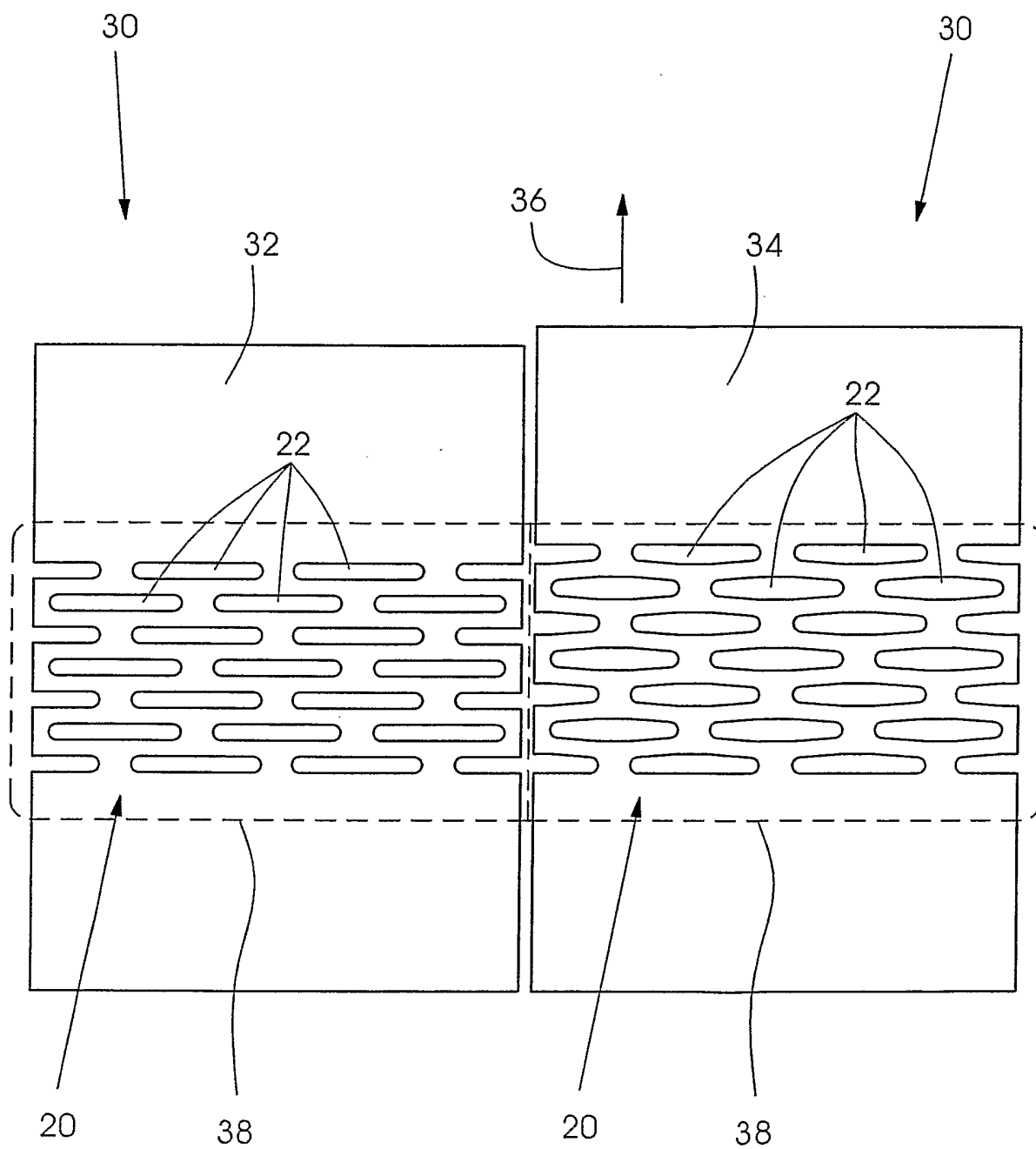

Fig.1

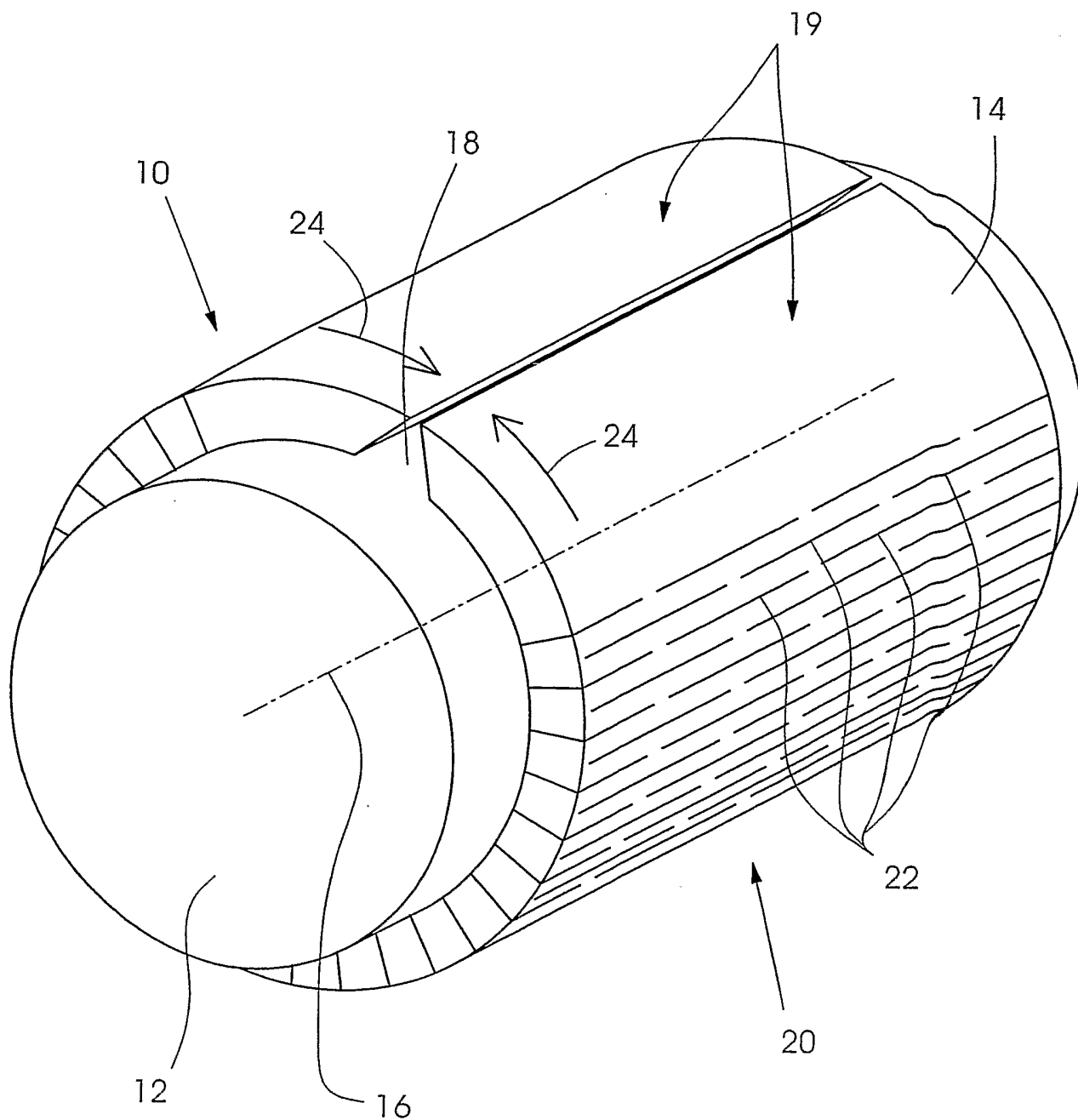

Fig.2

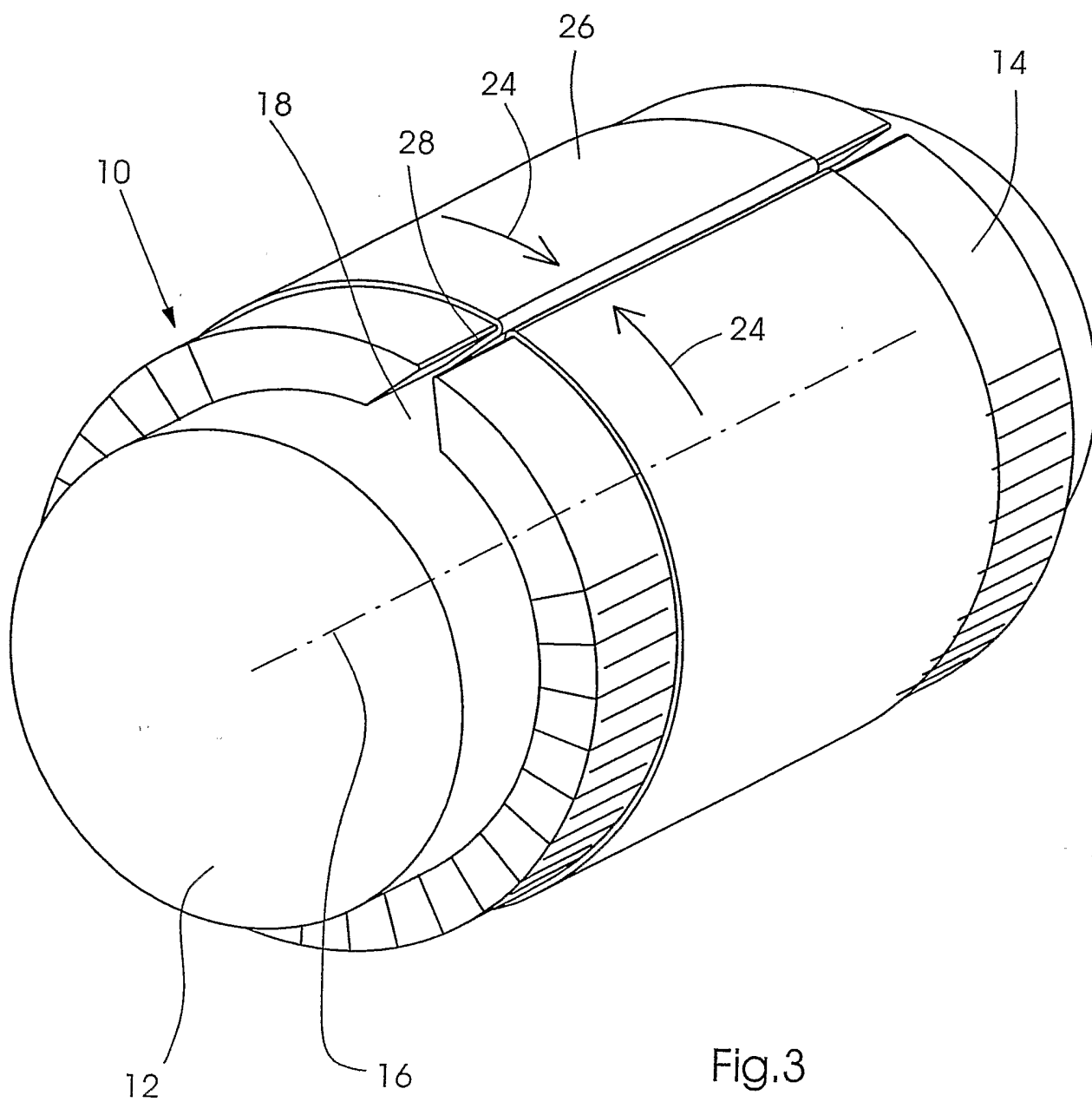

Fig.3

INTERNATIONAL SEARCH REPORT

International Application No
PCT/IB2005/000776

A. CLASSIFICATION OF SUBJECT MATTER
IPC 7 B41F27/14

According to International Patent Classification (IPC) or to both national classification and IPC

B. FIELDS SEARCHED

Minimum documentation searched (classification system followed by classification symbols)
IPC 7 B41F

Documentation searched other than minimum documentation to the extent that such documents are included in the fields searched

Electronic data base consulted during the international search (name of data base and, where practical, search terms used)

EPO-Internal, WPI Data

C. DOCUMENTS CONSIDERED TO BE RELEVANT

Category *	Citation of document, with indication, where appropriate, of the relevant passages	Relevant to claim No.
X	DE 199 18 432 A1 (SAUERESSIG GMBH & CO) 26 October 2000 (2000-10-26)	1-5, 10
Y	column 3, lines 1-18, 37-40	7, 9
A	US 5 813 336 A (GUARALDI ET AL) 29 September 1998 (1998-09-29)	1, 7, 9, 10
Y	column 2, lines 47-67 column 8, lines 1-5, 33-40 figure 8a	7, 9
A	EP 1 375 145 A (DUCHENAUD UNIFLEXO) 2 January 2004 (2004-01-02)	1, 10
A	column 1, paragraphs 1, 2, 4	
A	US 3 820 460 A (MC ELREATH C, US) 28 June 1974 (1974-06-28)	1
	column 1, lines 53-67	

Further documents are listed in the continuation of box C.

Patent family members are listed in annex.

* Special categories of cited documents :

- *A* document defining the general state of the art which is not considered to be of particular relevance
- *E* earlier document but published on or after the international filing date
- *L* document which may throw doubts on priority claim(s) or which is cited to establish the publication date of another citation or other special reason (as specified)
- *O* document referring to an oral disclosure, use, exhibition or other means
- *P* document published prior to the international filing date but later than the priority date claimed

- *T* later document published after the international filing date or priority date and not in conflict with the application but cited to understand the principle or theory underlying the invention
- *X* document of particular relevance; the claimed invention cannot be considered novel or cannot be considered to involve an inventive step when the document is taken alone
- *Y* document of particular relevance; the claimed invention cannot be considered to involve an inventive step when the document is combined with one or more other such documents, such combination being obvious to a person skilled in the art.
- *&* document member of the same patent family

Date of the actual completion of the international search

20 June 2005

Date of mailing of the international search report

01/07/2005

Name and mailing address of the ISA

European Patent Office, P.B. 5818 Patentlaan 2
NL - 2280 HV Rijswijk
Tel. (+31-70) 340-2040, Tx. 31 651 epo nl,
Fax: (+31-70) 340-3016

Authorized officer

Curt, D

INTERNATIONAL SEARCH REPORT

 In International Application No
 PCT/IB2005/000776

Patent document cited in search report		Publication date	Patent family member(s)	Publication date
DE 19918432	A1	26-10-2000	AU 4536800 A WO 0064675 A1 EP 1177100 A1 US 6823787 B1	10-11-2000 02-11-2000 06-02-2002 30-11-2004
US 5813336	A	29-09-1998	DE 19646135 A1 JP 9183208 A US 6109180 A	26-06-1997 15-07-1997 29-08-2000
EP 1375145	A	02-01-2004	FR 2841176 A1 DE 03356096 T1 EP 1375145 A2 ES 2217997 T1	26-12-2003 21-10-2004 02-01-2004 16-11-2004
US 3820460	A	28-06-1974	NONE	