



INTERNATIONAL APPLICATION PUBLISHED UNDER THE PATENT COOPERATION TREATY (PCT)

<p>(51) International Patent Classification ⁶ : A61B 17/22</p>	<p>A1</p>	<p>(11) International Publication Number: WO 99/53849 (43) International Publication Date: 28 October 1999 (28.10.99)</p>
<p>(21) International Application Number: PCT/US99/08487 (22) International Filing Date: 22 April 1999 (22.04.99)</p> <p>(30) Priority Data: 60/082,810 23 April 1998 (23.04.98) US 60/105,448 23 October 1998 (23.10.98) US</p> <p>(71) Applicant: SCIMED LIFE SYSTEMS, INC. [US/US]; One Scimed Place, Maple Grove, MN 55311-1566 (US). (72) Inventor: LEVEILLEE, Raymond, J.; 11302 Knot Way, Cooper City, FL 33026 (US). (74) Agent: MOORE, Ronda, P.; Testa, Hurwitz & Thibault, LLP, High Street Tower, 125 High Street, Boston, MA 02110 (US).</p>		<p>(81) Designated States: CA, JP, European patent (AT, BE, CH, CY, DE, DK, ES, FI, FR, GB, GR, IE, IT, LU, MC, NL, PT, SE).</p> <p>Published <i>With international search report. Before the expiration of the time limit for amending the claims and to be republished in the event of the receipt of amendments.</i></p>

(54) Title: MEDICAL RETRIEVAL DEVICE WITH LOOP BASKET

(57) Abstract

Basket with atraumatic distal tips allow the capture of material from difficult-to-reach areas of the body, while reducing the risk of tissue damage.

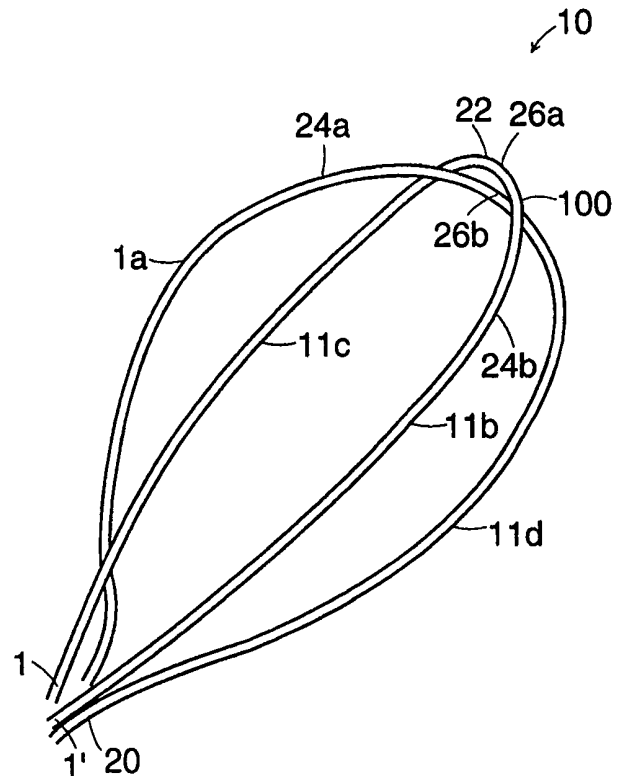

FOR THE PURPOSES OF INFORMATION ONLY

Codes used to identify States party to the PCT on the front pages of pamphlets publishing international applications under the PCT.

AL	Albania	ES	Spain	LS	Lesotho	SI	Slovenia
AM	Armenia	FI	Finland	LT	Lithuania	SK	Slovakia
AT	Austria	FR	France	LU	Luxembourg	SN	Senegal
AU	Australia	GA	Gabon	LV	Latvia	SZ	Swaziland
AZ	Azerbaijan	GB	United Kingdom	MC	Monaco	TD	Chad
BA	Bosnia and Herzegovina	GE	Georgia	MD	Republic of Moldova	TG	Togo
BB	Barbados	GH	Ghana	MG	Madagascar	TJ	Tajikistan
BE	Belgium	GN	Guinea	MK	The former Yugoslav Republic of Macedonia	TM	Turkmenistan
BF	Burkina Faso	GR	Greece			TR	Turkey
BG	Bulgaria	HU	Hungary	ML	Mali	TT	Trinidad and Tobago
BJ	Benin	IE	Ireland	MN	Mongolia	UA	Ukraine
BR	Brazil	IL	Israel	MR	Mauritania	UG	Uganda
BY	Belarus	IS	Iceland	MW	Malawi	US	United States of America
CA	Canada	IT	Italy	MX	Mexico	UZ	Uzbekistan
CF	Central African Republic	JP	Japan	NE	Niger	VN	Viet Nam
CG	Congo	KE	Kenya	NL	Netherlands	YU	Yugoslavia
CH	Switzerland	KG	Kyrgyzstan	NO	Norway	ZW	Zimbabwe
CI	Côte d'Ivoire	KP	Democratic People's Republic of Korea	NZ	New Zealand		
CM	Cameroon		Republic of Korea	PL	Poland		
CN	China	KR	Republic of Korea	PT	Portugal		
CU	Cuba	KZ	Kazakstan	RO	Romania		
CZ	Czech Republic	LC	Saint Lucia	RU	Russian Federation		
DE	Germany	LI	Liechtenstein	SD	Sudan		
DK	Denmark	LK	Sri Lanka	SE	Sweden		
EE	Estonia	LR	Liberia	SG	Singapore		

MEDICAL RETRIEVAL DEVICE WITH LOOP BASKET

Cross-Reference to Related Applications

This application is based on and claims priority to provisional U.S. patent application serial number 60/082,810 which was filed on April 23, 1998, and U.S. provisional patent application serial number 60/105,448 which was filed on October 23, 1998.

Technical Field

5 The invention relates generally to medical devices for retrieving material from within a body. More particularly, the invention relates to medical retrieval baskets that have atraumatic distal ends that are contoured or tipless both to minimize the chances of damage to tissue during use and to enhance the ability of the basket to capture material (e.g., stones) disposed or lodged in “pockets” or other areas that are difficult to access in the body.

Background Information

10 Known stone retrieval devices typically have baskets that are constructed by joining multiple legs together at a base of the basket and at a distal end or tip of the basket such that a “cage” is formed. At the distal tip, the individual legs are joined by soldering, adhesives, etc. such that a protruding tip results. This protrusion or outward projection at the distal end of the basket
15 can poke tissue and cause tissue trauma. In general, the tips or ends of known baskets protrude outward and thus can cause damage by poking or piercing tissue. Also, the protruding tips of known baskets generally do not permit access to or intimate contact with certain areas within the body such as “pockets,” and thus stones residing in such areas are difficult or impossible to retrieve with known baskets.

- 2 -

Summary of the Invention

It is an object of the invention to provide a medical retrieval basket that does not have a substantially protruding distal basket end or basket tip. That is, a basket according to the invention is atraumatic and does not have any significant distal protrusion or outward projection
5 that can poke tissue, pierce tissue, or otherwise cause trauma to tissue.

It is another object of the invention to provide a medical retrieval basket that permits access to and/or intimate contact with certain areas within the body such as "pockets" where material to be retrieved (e.g., stones) might reside or be lodged, impacted, or embedded. A tipless or contoured tip basket arrangement can access these areas and retrieve material from
10 those areas whereas a conventional basket with a traumatic tip would not be able to do so because of the traumatic protruding tip that prevents intimate contact between the distal end of the basket and body tissue.

It is yet another object of the invention to provide a method of using such baskets to retrieve material from within a body. The material can be biological or foreign matter. The
15 material can be, for example, urological stones or any of a variety of other types of material found in the body.

A basket according to the invention is formed by a plurality of wires, each wire forming a loop. Thus, the basket according to the invention is tipless and atraumatic, and lacks a protruding
distal tip.

The invention generally relates to a medical retrieval device. The device comprises a
20 sheath, a handle, and an atraumatic basket. The sheath has a proximal end and a distal end. The handle is located at the proximal end of the sheath. The basket can remove material from a body, and it is moveable between a collapsed position when the basket is enclosed within the sheath and an expanded position when the basket is extended from the distal end of the sheath. The basket
25 has four or more legs (e.g., six, or eight legs). At least a distal end portion of the atraumatic basket is tipless and formed by a plurality of wires, each wire forming a loop. The apex of each of the loops is positioned at the distal end of the basket. The ends of each loop are attached to one another at the basket base or to an elongated member. The loops are unattached and freely
moveable at the distal end of the basket.

The foregoing and other objects, aspects, features, and advantages of the invention will
30 become more apparent from the following description and from the claims.

- 3 -

Brief Description of the Drawings

In the drawings, like reference characters generally refer to the same parts throughout the different views. Also, the drawings are not necessarily to scale, emphasis instead generally being placed upon illustrating the principles of the invention.

5 FIG. 1A illustrates one embodiment of a medical retrieval device with an atraumatic basket according to the invention with the basket in an expanded position.

FIG. 1B illustrates one embodiment of a medical retrieval device with an atraumatic basket according to the invention with the basket in a collapsed position.

10 FIG. 2A illustrates an embodiment according to the invention of a basket formed by a plurality of loops, the loops being unattached where the loops intersect at the distal end of the basket.

FIG. 2B illustrates an embodiment according to the invention of another embodiment of the basket illustrated in FIG. 2A comprising more than two basket loops.

Description

15 The basket 10 shown in FIG. 1A is the type that can be collapsed within a sheath 12 for entry into the body. A medical device or extractor 6 that includes the basket 10 of the invention also includes the sheath 12 and a proximal handle 8. The handle 8, sheath 12 and basket 10 illustrated in FIGS. 1A and 1B are not shown in their correct size or proportion to each other. The sheath 12 has at least one lumen 14 therein, and it extends from the handle 8 to a distal sheath
20 end 16. An elongated member such as a cable, coil, shaft, guidewire or mandril wire 18 extends within the lumen 14 from an actuating mechanism 4 at the device handle 8 to the base 20 of the basket 10 where the cable 18 is attached to the basket base 20. Operation of the actuating mechanism 4 by an operator causes the basket 10 to move relative to the sheath 12 between a collapsed position within the sheath 12 as illustrated in FIG. 1B to an extended position outside of
25 the sheath 12 where the basket 10 is open/expanded and extending beyond the distal end of the sheath 16 as shown in FIG. 1A. Alternatively, the mechanism 4 can cause movement of the sheath 12 to advance the sheath 12 over the stationary basket 10 and cable 18 combination, to thereby collapse the basket 10 within the sheath 12, and the mechanism 4 can slide the moveable sheath 12 back to expose the stationary basket 10 and allow it to open/expand. In general, both
30 types of basket/sheath movement configurations and related handle mechanisms are known, and can be seen in existing product designs available from, for example, Boston Scientific Corporation

- 4 -

(Natick, MA). With the basket withdrawn into and collapsed within the sheath 12 as shown in FIG. 1B, the sheath 12 can be inserted into the body by an operator to a site in the body where the material to be retrieved is located (e.g., a stone in the ureter). The basket 10 is then moved relative to the sheath 12 and placed in the extended position, as illustrated in FIG. 1A, such that the basket 10 dilates the body tract and can be manipulated by the operator to entrap or capture material within the basket 10. The basket 10 can then be moved relative to the sheath 12 to cause the legs 11a, 11b, 11c, 11d of the basket 10 to close around the material and capture it. The captured material is then withdrawn from the body along with the sheath and the basket that is holding the material.

Referring to FIGS. 2A and 2B, a tiplless end 22 of the atraumatic basket 10 is constructed by using single wires to form loops 24a, 24b having legs 11a, 11b, 11c, 11d extending from the apex 26a, 26b of the loops 24a and 24, respectively, the apex 26a, 26b positioned at the basket distal end 22. A plurality of pre-formed wire loops is included in a three-dimensional, atraumatic basket. In this embodiment of an atraumatic wire basket, for example, two wire loops 24a, 24b may be used to form a basket with four legs 11a, 11b, 11c, 11d as shown in FIG. 2A, and three wire loops 24a, 24b, 24c may be used to form a basket with six legs 11a, 11b, 11c, 11d, 11e, 11f as shown in FIG. 2B. Additional wire loops may be used to form a basket with more than the four or six legs shown. The apex 26 of each wire loop 24 intersects the apex 26 of the other wire loops 24 of the basket 10 at the basket distal end 22. The wire loops 24 at the basket distal end are free to slide by one another, i.e., they are not affixed, fused, soldered, welded, glued, joined, secured or attached to one another. The advantages of this configuration of the basket distal end 22 is that the basket end 22 is atraumatic and provides flexibility thereby enhancing the ease by which stones are captured. The two end-sections 1, 1' of each wire loop are brought together at the basket base 20 and held in place by welding, soldering, ligating, gluing, crimping or any other means known in the art. In one embodiment, the end-sections 1, 1' of the wire loops are affixed (not shown) to a cable, coil, shaft, mandril wire or guidewire 18 that runs longitudinally in a sheath 12 as shown in FIG. 1A and FIG. 1B.

In yet another aspect, the invention relates to a method for retrieving material from a body such as a body tract or body canal. Material (e.g., biological or foreign) can be retrieved from a body by using a tiplless, atraumatic wire basket, each wire forming a loop and having an atraumatic distal basket end according to the invention. The basket of the retrieval device has an

- 5 -

atraumatic distal end and thus allows the capture of material that is located in pockets or other difficult-to-access areas within the body. Because the distal basket end is atraumatic, it can make intimate contact with the surface of tissue, even the walls or lining of a pocket-type area, and allow the retrieval of stones or other materials that are unrecoverable with conventional tipped baskets that can cause tissue trauma and are limited in how close the basket can get to the tissue by the existence of the protruding tip. A method for retrieving material from a body includes inserting a retrieval device according to the invention into the body, moving the tipless basket into the extended position, maneuvering the basket via the proximal handle (which is located outside of the body) of the retrieval device until the material (e.g., stone) is entrapped within the three-dimensional basket structure, and then capturing the material within the basket by moving the basket relative to the sheath to close the basket legs around the material. With the material so gripped or held by the basket, the basket can be withdrawn from the body to remove the material from the body. The materials that can be captured with tipless baskets according to the invention include a calculus, or a stone, such as a kidney stone, a ureteral stone, a urinary bladder stone, a gall bladder stone, or a stone within the biliary tree.

Variations, modifications, and other implementations of what is described herein will occur to those of ordinary skill in the art without departing from the spirit and the scope of the invention as claimed. Accordingly, the invention is to be defined not by the preceding illustrative description but instead by the spirit and scope of the following claims.

What is claimed is:

- 6 -

Claims

1 1. A medical retrieval device, comprising:
2 a sheath having a proximal end and a distal end;
3 a handle at the proximal end of the sheath; and
4 a basket for removing material from a body, the basket having a collapsed position where
5 the basket is enclosed within the sheath and an expanded position where the basket extends from
6 the distal end of the sheath, the basket comprising two or more pairs of basket legs, each pair of
7 basket legs formed from a single wire loop, and each pair of said basket legs crossing each other
8 and being unattached and freely moveable with respect to each other at a distal end of the basket.

1 2. A method for retrieving material from a body, comprising:
2 inserting a retrieval device into a body, the retrieval device comprising a sheath having a
3 proximal end and a distal end, a handle at the proximal end of the sheath, and a basket for
4 removing material from a body, the basket having a collapsed position where the basket is
5 enclosed within the sheath, and an expanded position where the basket extends from the distal end
6 of the sheath, the basket comprising two or more pairs of basket legs, each pair of basket legs
7 formed from a single wire loop, and each pair of said basket legs crossing each other and being
8 unattached and freely moveable with respect to each other at a distal end of the basket;
9 capturing the material within the basket; and
10 withdrawing the retrieval device from the body to remove the captured material from the
11 body.

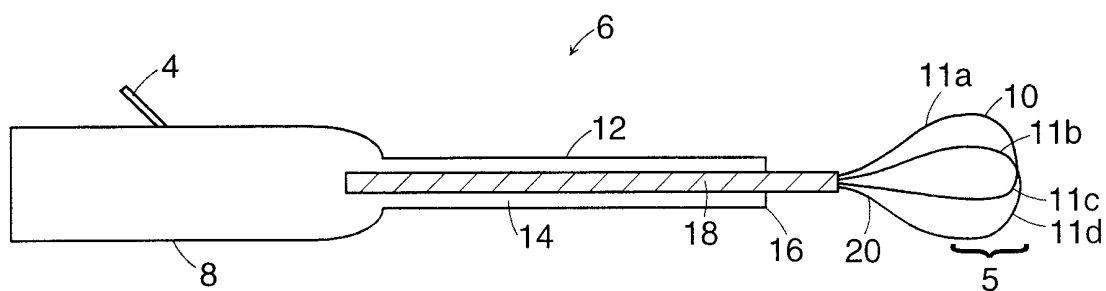

FIG. 1a

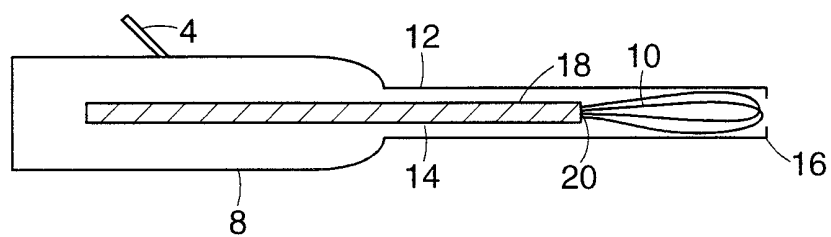

FIG. 1b

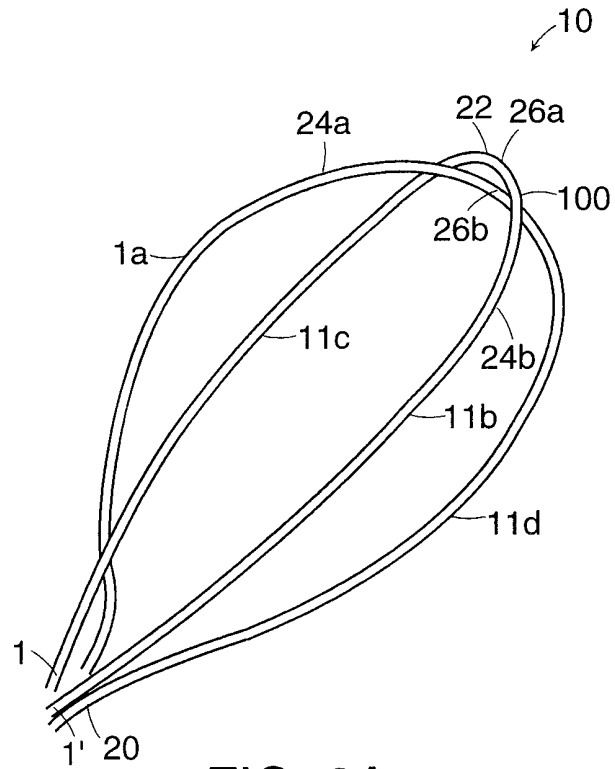

FIG. 2A

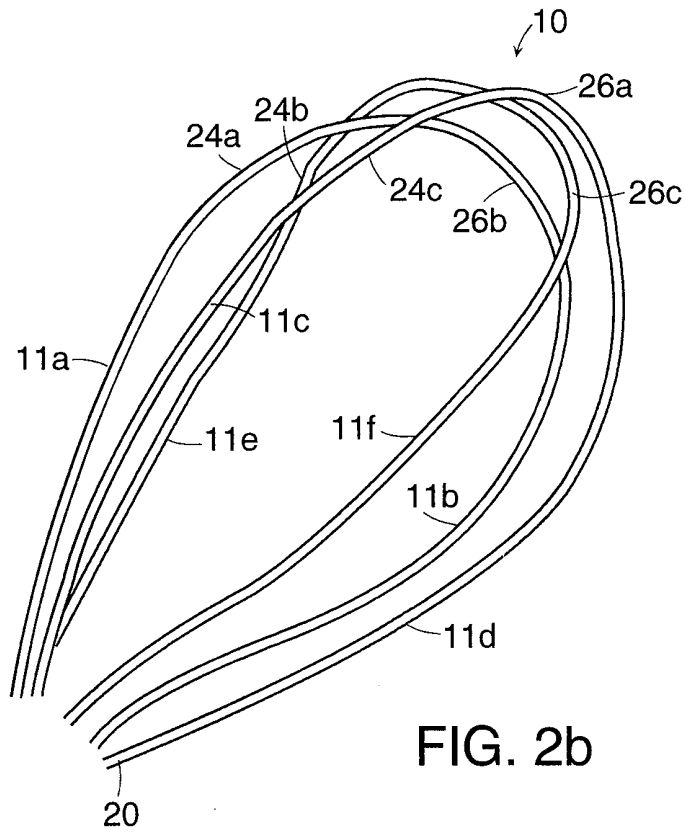

FIG. 2b

INTERNATIONAL SEARCH REPORT

International Application No

PCT/US 99/08487

A. CLASSIFICATION OF SUBJECT MATTER

IPC 6 A61B17/22

According to International Patent Classification (IPC) or to both national classification and IPC

B. FIELDS SEARCHED

Minimum documentation searched (classification system followed by classification symbols)

IPC 6 A61B

Documentation searched other than minimum documentation to the extent that such documents are included in the fields searched

Electronic data base consulted during the international search (name of data base and, where practical, search terms used)

C. DOCUMENTS CONSIDERED TO BE RELEVANT

Category *	Citation of document, with indication, where appropriate, of the relevant passages	Relevant to claim No.
X	EP 0 123 175 A (KORTH KNUT DR ; ANGIOMED GMBH (DE)) 31 October 1984 (1984-10-31) page 10, line 11 - line 18 page 10, line 33 - page 11, line 5; figure 3 ---	1
X	CH 480 059 A (TIMOTIJEVIC ET AL.) 31 October 1969 (1969-10-31) the whole document ---	1
X	DE 42 12 430 A (DIEMER FRANZ) 21 October 1993 (1993-10-21) the whole document -----	1

Further documents are listed in the continuation of box C.

Patent family members are listed in annex.

* Special categories of cited documents :

- "A" document defining the general state of the art which is not considered to be of particular relevance
- "E" earlier document but published on or after the international filing date
- "L" document which may throw doubts on priority claim(s) or which is cited to establish the publication date of another citation or other special reason (as specified)
- "O" document referring to an oral disclosure, use, exhibition or other means
- "P" document published prior to the international filing date but later than the priority date claimed

- "T" later document published after the international filing date or priority date and not in conflict with the application but cited to understand the principle or theory underlying the invention
- "X" document of particular relevance; the claimed invention cannot be considered novel or cannot be considered to involve an inventive step when the document is taken alone
- "Y" document of particular relevance; the claimed invention cannot be considered to involve an inventive step when the document is combined with one or more other such documents, such combination being obvious to a person skilled in the art.
- "&" document member of the same patent family

Date of the actual completion of the international search

17 August 1999

Date of mailing of the international search report

25/08/1999

Name and mailing address of the ISA

European Patent Office, P.B. 5818 Patentlaan 2
NL - 2280 HV Rijswijk
Tel. (+31-70) 340-2040, Tx. 31 651 epo.nl,
Fax: (+31-70) 340-3016

Authorized officer

Hansen, S

INTERNATIONAL SEARCH REPORT

Information on patent family members

International Application No

PCT/US 99/08487

Patent document cited in search report	Publication date	Patent family member(s)	Publication date
EP 0123175 A	31-10-1984	DE 3313895 A DE 3408661 A AT 22222 T	25-10-1984 24-10-1985 15-10-1986
CH 480059 A	31-10-1969	NONE	
DE 4212430 A	21-10-1993	NONE	

INTERNATIONAL SEARCH REPORT

International application No.

PCT/US 99/ 08487

Box I Observations where certain claims were found unsearchable (Continuation of item 1 of first sheet)

This International Search Report has not been established in respect of certain claims under Article 17(2)(a) for the following reasons:

1. Claims Nos.: 2
because they relate to subject matter not required to be searched by this Authority, namely:
Rule 39.1(iv) PCT - Method for treatment of the human or animal body by surgery
2. Claims Nos.:
because they relate to parts of the International Application that do not comply with the prescribed requirements to such an extent that no meaningful International Search can be carried out, specifically:
3. Claims Nos.:
because they are dependent claims and are not drafted in accordance with the second and third sentences of Rule 6.4(a).

Box II Observations where unity of invention is lacking (Continuation of item 2 of first sheet)

This International Searching Authority found multiple inventions in this international application, as follows:

1. As all required additional search fees were timely paid by the applicant, this International Search Report covers all searchable claims.
2. As all searchable claims could be searched without effort justifying an additional fee, this Authority did not invite payment of any additional fee.
3. As only some of the required additional search fees were timely paid by the applicant, this International Search Report covers only those claims for which fees were paid, specifically claims Nos.:
4. No required additional search fees were timely paid by the applicant. Consequently, this International Search Report is restricted to the invention first mentioned in the claims; it is covered by claims Nos.:

Remark on Protest

- The additional search fees were accompanied by the applicant's protest.
- No protest accompanied the payment of additional search fees.