

(19) World Intellectual Property Organization  
International Bureau



(43) International Publication Date  
25 January 2007 (25.01.2007)

PCT

(10) International Publication Number  
**WO 2007/011789 A1**

(51) International Patent Classification:

*H01L 29/15* (2006.01)     *H01L 21/336* (2006.01)  
*H01L 29/10* (2006.01)     *H01L 21/8234* (2006.01)

(21) International Application Number:

PCT/US2006/027503

(22) International Filing Date: 14 July 2006 (14.07.2006)

(25) Filing Language: English

(26) Publication Language: English

(30) Priority Data:

60/699,949     15 July 2005 (15.07.2005)     US  
11/457,269     13 July 2006 (13.07.2006)     US  
11/457,276     13 July 2006 (13.07.2006)     US

(71) Applicant (for all designated States except US): **RJ MEARS, LLC** [US/US]; 1100 Winter Street, Suite 4700, Waltham, MA 02451 (US).

(72) Inventors; and

(75) Inventors/Applicants (for US only): **MEARS, Robert, J.** [GB/US]; 14 Summit Road, Wellesley, MA 02482 (US).  
**KREPS, Scott, A.** [US/US]; 4 Cross Street, Southborough, MA 01772 (US).

(74) Agents: **REGAN, Christopher F.** et al.; 255 S. Orange Ave, Suite 1401, Orlando, FL 32802-3791 (US).

(81) Designated States (unless otherwise indicated, for every kind of national protection available): AE, AG, AL, AM, AT, AU, AZ, BA, BB, BG, BR, BW, BY, BZ, CA, CH, CN, CO, CR, CU, CZ, DE, DK, DM, DZ, EC, EE, EG, ES, FI, GB, GD, GE, GH, GM, HN, HR, HU, ID, IL, IN, IS, JP, KE, KG, KM, KN, KP, KR, KZ, LA, LC, LK, LR, LS, LT, LU, LV, LY, MA, MD, MG, MK, MN, MW, MX, MZ, NA, NG, NI, NO, NZ, OM, PG, PH, PL, PT, RO, RS, RU, SC, SD, SE, SG, SK, SL, SM, SY, TJ, TM, TN, TR, TT, TZ, UA, UG, US, UZ, VC, VN, ZA, ZM, ZW.

(84) Designated States (unless otherwise indicated, for every kind of regional protection available): ARIPO (BW, GH, GM, KE, LS, MW, MZ, NA, SD, SL, SZ, TZ, UG, ZM, ZW), Eurasian (AM, AZ, BY, KG, KZ, MD, RU, TJ, TM), European (AT, BE, BG, CH, CY, CZ, DE, DK, EE, ES, FI, FR, GB, GR, HU, IE, IS, IT, LT, LU, LV, MC, NL, PL, PT, RO, SE, SI, SK, TR), OAPI (BF, BJ, CF, CG, CI, CM, GA, GN, GQ, GW, ML, MR, NE, SN, TD, TG).

Published:

— with international search report

For two-letter codes and other abbreviations, refer to the "Guidance Notes on Codes and Abbreviations" appearing at the beginning of each regular issue of the PCT Gazette.

(54) Title: SEMICONDUCTOR DEVICE INCLUDING A STRAINED SUPERLATTICE BETWEEN AT LEAST ONE PAIR OF SPACED APART STRESS REGIONS AND ASSOCIATED METHODS

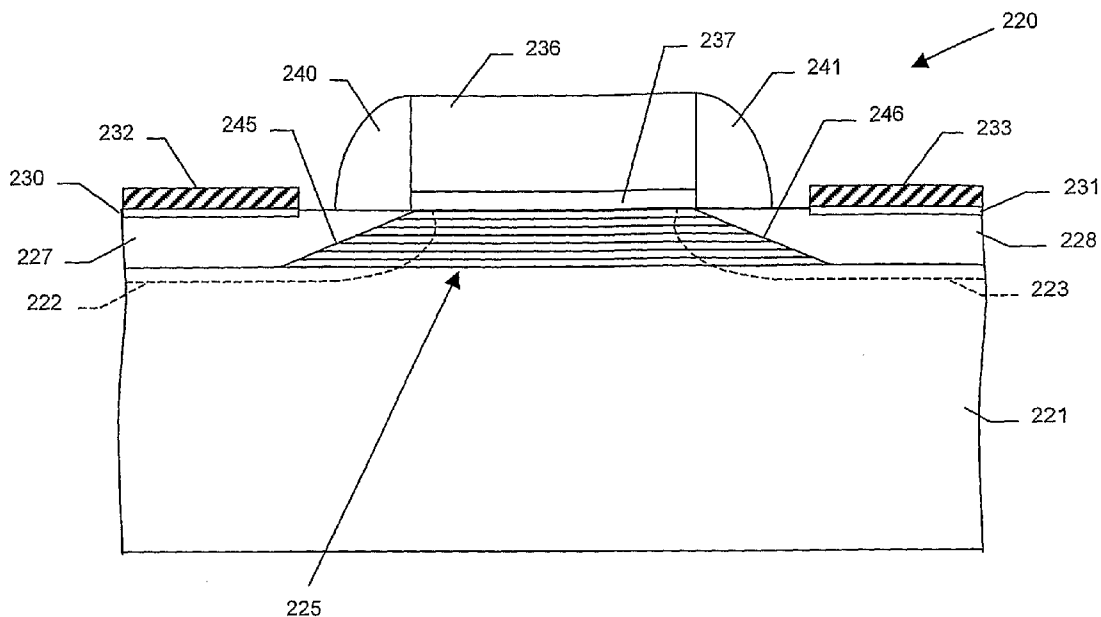

(57) Abstract: A semiconductor device may include at least one pair of spaced apart stress regions (227, 228), and a strained superlattice layer (225) between the at least one pair of spaced apart stress regions and including a plurality of stacked groups of layers. Each group of layers of the strained superlattice layer may include a plurality of stacked base semiconductor monolayers defining a base semiconductor portion and at least one non-semiconductor monolayer constrained within a crystal lattice of adjacent base semiconductor portions.

WO 2007/011789 A1

**SEMICONDUCTOR DEVICE INCLUDING A STRAINED SUPERLATTICE  
BETWEEN AT LEAST ONE PAIR OF SPACED APART STRESS REGIONS  
AND ASSOCIATED METHODS**

**Field of the Invention**

[0001] The present invention relates to the field of semiconductors, and, more particularly, to semiconductors having enhanced properties based upon energy band engineering and associated methods.

**Background of the Invention**

[0002] Structures and techniques have been proposed to enhance the performance of semiconductor devices, such as by enhancing the mobility of the charge carriers. For example, U.S. Patent Application No. 2003/0057416 to Currie et al. discloses strained material layers of silicon, silicon-germanium, and relaxed silicon and also including impurity-free zones that would otherwise cause performance degradation. The resulting biaxial strain in the upper silicon layer alters the carrier mobilities enabling higher speed and/or lower power devices. Published U.S. Patent Application No. 2003/0034529 to Fitzgerald et al. discloses a CMOS inverter also based upon similar strained silicon technology.

[0003] U.S. Patent No. 6,472,685 B2 to Takagi discloses a semiconductor device including a silicon and carbon layer sandwiched between silicon layers so that the conduction band and valence band of the second silicon layer receive a tensile strain. Electrons having a smaller effective mass, and which have been induced by an electric field applied to the gate electrode, are confined in the second silicon layer, thus, an n-channel MOSFET is asserted to have a higher mobility.

[0004] U.S. Patent No. 4,937,204 to Ishibashi et al. discloses a superlattice in which a plurality of layers, less than eight monolayers, and containing a fraction or a binary compound semiconductor layers, are alternately and epitaxially grown. The direction of main current flow is perpendicular to the layers of the superlattice.

[0005] U.S. Patent No. 5,357,119 to Wang et al. discloses a Si-Ge short period superlattice with higher mobility achieved by reducing alloy scattering in the superlattice. Along these lines, U.S. Patent No. 5,683,934 to Candelaria discloses an enhanced mobility MOSFET including a channel layer comprising an alloy of silicon and a second material substitutionally present in the silicon lattice at a percentage that places the channel layer under tensile stress.

[0006] U.S. Patent No. 5,216,262 to Tsu discloses a quantum well structure comprising two barrier regions and a thin epitaxially grown semiconductor layer sandwiched between the barriers. Each barrier region consists of alternate layers of SiO<sub>2</sub>/Si with a thickness generally in a range of two to six monolayers. A much thicker section of silicon is sandwiched between the barriers.

[0007] An article entitled "Phenomena in silicon nanostructure devices" also to Tsu and published online September 6, 2000 by Applied Physics and Materials Science & Processing, pp. 391-402 discloses a semiconductor-atomic superlattice (SAS) of silicon and oxygen. The Si/O superlattice is disclosed as useful in a silicon quantum and light-emitting devices. In particular, a green electroluminescence diode structure was constructed and tested. Current flow in the diode structure is vertical, that is, perpendicular to the layers of the SAS. The disclosed SAS may include semiconductor layers separated by adsorbed species such as oxygen atoms, and CO molecules. The silicon growth beyond the adsorbed monolayer of oxygen is described as epitaxial with a fairly low defect density. One SAS structure included a 1.1 nm thick silicon portion that is about eight atomic layers of silicon, and another structure had twice this thickness of silicon. An article to Luo et al. entitled "Chemical Design of Direct-Gap Light-Emitting Silicon" published in Physical Review Letters, Vol. 89, No. 7 (August 12, 2002) further discusses the light emitting SAS structures of Tsu.

[0008] Published International Application WO 02/103,767 A1 to Wang, Tsu and Lofgren, discloses a barrier building block of thin silicon and oxygen, carbon, nitrogen, phosphorous, antimony, arsenic or hydrogen to thereby reduce current flowing vertically through the lattice more than four orders of magnitude. The insulating layer/barrier layer allows for low defect epitaxial silicon to be deposited next to the insulating layer.

[0009] Published Great Britain Patent Application 2,347,520 to Mears et al. discloses that principles of Aperiodic Photonic Band-Gap (APBG) structures may be adapted for electronic bandgap engineering. In particular, the application discloses that material parameters, for example, the location of band minima, effective mass, etc., can be tailored to yield new aperiodic materials with desirable band-structure characteristics. Other parameters, such as electrical conductivity, thermal conductivity and dielectric permittivity or magnetic permeability are disclosed as also possible to be designed into the material. Despite considerable efforts at materials engineering to increase the mobility of charge carriers in semiconductor devices, there is still a need for greater improvements. Greater mobility may increase device speed and/or reduce device power consumption. With greater mobility, device performance can also be maintained despite the continued shift to smaller devices and new device configurations.

#### Summary of the Invention

[0010] In view of the foregoing background, it is therefore an object of the present invention to provide a semiconductor device with enhanced operating characteristics.

[0011] This and other objects, features, and advantages in accordance with the present invention are provided by a semiconductor device which may include at least one pair of spaced apart stress regions, and a strained superlattice layer between the at least one pair of spaced apart stress regions and including a plurality of stacked groups of layers. More particularly, each

group of layers of the strained superlattice layer may include a plurality of stacked base semiconductor monolayers defining a base semiconductor portion and at least one non-semiconductor monolayer constrained within a crystal lattice of adjacent base semiconductor portions.

[0012] At least one of the stress regions may include silicon and germanium. Further, the at least one pair of spaced apart stress regions may be at least one pair of source and drain regions, for example. Moreover, at least one of the stress regions may have a canted surface adjacent opposing portions of the strained superlattice. In addition, the semiconductor device may also include a semiconductor substrate below the at least one pair of spaced apart stress regions and the strained superlattice layer.

[0013] The strained superlattice layer may have a compressive and/or tensile strain. The strained superlattice layer may also have a common energy band structure therein. By way of example, each base semiconductor portion may include a base semiconductor selected from the group consisting of Group IV semiconductors, Group III-V semiconductors, and Group II-VI semiconductors. More particularly, each base semiconductor portion may include silicon. Moreover, each non-semiconductor monolayer may include a non-semiconductor selected from the group consisting of oxygen, nitrogen, fluorine, and carbon-oxygen.

[0014] Adjacent base semiconductor portions of the strained superlattice layer may be chemically bound together. Furthermore, each non-semiconductor monolayer

may be a single monolayer thick, and each base semiconductor portion may be less than eight monolayers thick. The strained superlattice layer may also have a substantially direct energy bandgap. The strained superlattice layer may also include a base semiconductor cap layer on an uppermost group of layers. In some embodiments, all of the base semiconductor portions may be a same number of monolayers thick. Alternatively, at least some of the base semiconductor portions may be a different number of monolayers thick.

[0015] A method aspect is for making a semiconductor device. The method may include forming a superlattice layer comprising a plurality of stacked groups of layers, and forming at least one pair of spaced apart stress regions on opposing sides of the superlattice layer to induce a strain therein. Each group of layers of the strained superlattice layer may comprise a plurality of stacked base semiconductor monolayers defining a base semiconductor portion and at least one non-semiconductor monolayer constrained within a crystal lattice of adjacent base semiconductor portions

#### Brief Description of the Drawings

[0016] FIG. 1 is a schematic cross-sectional view of a semiconductor device in accordance with the present invention including a stress layer and a strained superlattice above the stress layer.

[0017] FIG. 2 is a greatly enlarged schematic cross-sectional view of the superlattice as shown in FIG. 1.

[0018] FIG. 3 is a perspective schematic atomic diagram of a portion of the superlattice shown in FIG. 1.

[0019] FIG. 4 is a greatly enlarged schematic cross-sectional view of another embodiment of a superlattice that may be used in the device of FIG. 1.

[0020] FIG. 5A is a graph of the calculated band structure from the gamma point (G) for both bulk silicon as in the prior art, and for the 4/1 Si/O superlattice as shown in FIGS. 1-3.

[0021] FIG. 5B is a graph of the calculated band structure from the Z point for both bulk silicon as in the prior art, and for the 4/1 Si/O superlattice as shown in FIGS. 1-3.

[0022] FIG. 5C is a graph of the calculated band structure from both the gamma and Z points for both bulk silicon as in the prior art, and for the 5/1/3/1 Si/O superlattice as shown in FIG. 4.

[0023] FIGS. 6 and 7 are schematic cross-sectional views of alternative embodiments of the semiconductor device of FIG. 1.

[0024] FIG. 8 is a schematic cross-sectional view of another semiconductor device embodiment in accordance with the present invention including a superlattice between a pair of spaced apart stress regions.

[0025] FIG. 9 is a schematic cross-sectional view of yet another semiconductor device embodiment in accordance with the present invention including a superlattice and a stress layer above the superlattice.

[0026] FIG. 10 is a schematic cross-sectional view of a MOSFET including a non-semiconductor monolayer in accordance with the present invention.



[0027] FIG. 11 is a simulated plot of density at the interface versus depth for the non-semiconductor monolayer of FIG. 10.

Detailed Description of the Preferred Embodiments

[0028] The present invention will now be described more fully hereinafter with reference to the accompanying drawings, in which preferred embodiments of the invention are shown. This invention may, however, be embodied in many different forms and should not be construed as limited to the embodiments set forth herein. Rather, these embodiments are provided so that this disclosure will be thorough and complete, and will fully convey the scope of the invention to those skilled in the art. Like numbers refer to like elements throughout, and prime and multiple prime notation are used to indicate similar elements in alternate embodiments.

[0029] The present invention relates to controlling the properties of semiconductor materials at the atomic or molecular level to achieve improved performance within semiconductor devices. Further, the invention relates to the identification, creation, and use of improved materials for use in the conduction paths of semiconductor devices.

[0030] Applicants theorize, without wishing to be bound thereto, that certain superlattices as described herein reduce the effective mass of charge carriers and that this thereby leads to higher charge carrier mobility. Effective mass is described with various definitions in the literature. As a measure of the improvement in effective mass Applicants use a

"conductivity reciprocal effective mass tensor",  $\mathbf{M}_e^{-1}$  and  $\mathbf{M}_h^{-1}$  for electrons and holes respectively, defined as:

$$\mathbf{M}_{e,ij}^{-1}(E_F, T) = \frac{\sum_{E > E_F} \int_{B.Z.} (\nabla_{\mathbf{k}} E(\mathbf{k}, n))_i (\nabla_{\mathbf{k}} E(\mathbf{k}, n))_j \frac{\partial f(E(\mathbf{k}, n), E_F, T)}{\partial E} d^3 \mathbf{k}}{\sum_{E > E_F} \int_{B.Z.} f(E(\mathbf{k}, n), E_F, T) d^3 \mathbf{k}}$$

for electrons and:

$$\mathbf{M}_{h,ij}^{-1}(E_F, T) = \frac{- \sum_{E < E_F} \int_{B.Z.} (\nabla_{\mathbf{k}} E(\mathbf{k}, n))_i (\nabla_{\mathbf{k}} E(\mathbf{k}, n))_j \frac{\partial f(E(\mathbf{k}, n), E_F, T)}{\partial E} d^3 \mathbf{k}}{\sum_{E < E_F} \int_{B.Z.} (1 - f(E(\mathbf{k}, n), E_F, T)) d^3 \mathbf{k}}$$

for holes, where  $f$  is the Fermi-Dirac distribution,  $E_F$  is the Fermi energy,  $T$  is the temperature,  $E(\mathbf{k}, n)$  is the energy of an electron in the state corresponding to wave vector  $\mathbf{k}$  and the  $n^{\text{th}}$  energy band, the indices  $i$  and  $j$  refer to Cartesian coordinates  $x$ ,  $y$  and  $z$ , the integrals are taken over the Brillouin zone (B.Z.), and the summations are taken over bands with energies above and below the Fermi energy for electrons and holes respectively.

[0031] Applicants' definition of the conductivity reciprocal effective mass tensor is such that a tensorial component of the conductivity of the material is greater for greater values of the corresponding component of the conductivity reciprocal effective mass tensor. Again Applicants theorize without wishing to be bound thereto

that the superlattices described herein set the values of the conductivity reciprocal effective mass tensor so as to enhance the conductive properties of the material, such as typically for a preferred direction of charge carrier transport. The inverse of the appropriate tensor element is referred to as the conductivity effective mass. In other words, to characterize semiconductor material structures, the conductivity effective mass for electrons/holes as described above and calculated in the direction of intended carrier transport is used to distinguish improved materials.

[0032] Using the above-described measures, one can select materials having improved band structures for specific purposes. One such example would be a strained superlattice 25 material for a channel region in a MOSFET device. A planar MOSFET 20 including the strained superlattice 25 in accordance with the invention is now first described with reference to FIG. 1. One skilled in the art, however, will appreciate that the materials identified herein could be used in many different types of semiconductor devices, such as discrete devices and/or integrated circuits. By way of example, another application in which the strained superlattice 25 may be used is in FINFETs, as further described in U.S. Application Serial No. 11/426,969, which is assigned to the present Assignee and is hereby incorporated herein in its entirety by reference.

[0033] The illustrated MOSFET 20 includes a substrate 21, a stress layer 26 on the substrate, semiconductor regions 27, 28 on the stress layer, and the strained superlattice layer 25 is on the stress layer between the

semiconductor regions. More particularly, the stress layer 26 may be a graded semiconductor layer, such as a graded silicon germanium layer. Moreover, the semiconductor regions 26, 27 may be silicon or silicon germanium regions, for example. The semiconductor regions 26, 27 are illustratively implanted with a dopant to provide source and drain regions 22, 23 of the MOSFET 20, as will be appreciated by those skilled in the art.

[0034] Various superlattice structures that may be used in the MOSFET 20 are discussed further below. In the case of a silicon-oxygen superlattice, the lattice spacing of the superlattice layer 25 would ordinarily be smaller than that of a silicon germanium stress layer 26. However, the stress layer 26 in this example induces a tensile strain in the superlattice layer 25, which may be used to provide further mobility enhancement in N-channel FETs, for example. Alternatively, the compositions of the superlattice layer 25 and stress layer 26 may be chosen so that the superlattice would otherwise have a larger lattice spacing than the stress layer. This would advantageously induce compressive strain in the superlattice layer 25 that may advantageously provide further mobility enhancement of the superlattice in P-channel FET devices, for example.

[0035] In the illustrated embodiment, the stress layer is a graded semiconductor layer graded in a vertical direction, and the strained superlattice 25 is vertically stacked on the graded semiconductor layer. In an alternative embodiment illustrated in FIG. 6, the MOSFET 20' further includes a substantially ungraded semiconductor layer 42' positioned between the graded

semiconductor layer 26' and a strained superlattice layer 425'. That is, the substantially ungraded semiconductor layer 42' has a substantially consistent composition of semiconductor material (e.g., silicon germanium) throughout from top to bottom and provides a buffer between the stress layer 26' and the superlattice layer 425'. More particularly, the substantially ungraded semiconductor layer 42' may have substantially the same composition as the semiconductor material at the top of the stress layer 42'. Further information on the use of graded and ungraded layers for straining an overlying semiconductor layer (e.g., silicon) may be found in U.S. Patent Publication Nos. 2005/0211982 to Lei et al, 2005/0054175 to Bauer, 2005/0224800 to Lindert et al., and 2005/0051795 to Arena et al., all of which are hereby incorporated herein in their entirety by reference.

[0036] Source/drain silicide layers 30, 31 and source/drain contacts 32, 33 illustratively overlie the source/drain regions 22, 23, as will be appreciated by those skilled in the art. A gate 35 illustratively includes a gate insulating layer 37 adjacent the channel provided by the strained superlattice layer 25, and a gate electrode layer 36 on the gate insulating layer. Sidewall spacers 40, 41 are also provided in the illustrated MOSFET 20.

[0037] It is also theorized that the semiconductor device, such as the illustrated MOSFET 20, enjoys a higher charge carrier mobility based upon the lower conductivity effective mass than would otherwise be present. In some embodiments, and as a result of the band engineering, the superlattice 25 may further have a

substantially direct energy bandgap that may be particularly advantageous for opto-electronic devices, for example, such as those set forth in the co-pending application entitled INTEGRATED CIRCUIT COMPRISING AN ACTIVE OPTICAL DEVICE HAVING AN ENERGY BAND ENGINEERED SUPERLATTICE, U.S. Patent Application Serial No. 10/936,903, which is assigned to the present Assignee and is hereby incorporated herein in its entirety by reference.

[0038] As will be appreciated by those skilled in the art, the source/drain regions 22, 23 and gate 35 of the MOSFET 20 may be considered as regions for causing the transport of charge carriers through the strained superlattice layer 25 in a parallel direction relative to the layers of the stacked groups 45a-45n, as will be discussed further below. That is, the channel of the device is defined within the superlattice 25. Other such regions are also contemplated by the present invention.

[0039] In certain embodiments, the superlattice 25 may advantageously act as an interface for the gate dielectric layer 37. For example, the channel region may be defined in the lower portion of the superlattice 25 (although some of the channel may also be defined in the semiconductor material below the superlattice), while the upper portion thereof insulates the channel from the dielectric layer 37. In still another embodiment, the channel may be defined solely in the stress layer 26, and the strained superlattice layer 25 may be included merely as an insulation/interface layer.

[0040] Use of the superlattice 25 as a dielectric interface layer may be particularly appropriate where

relatively high-K gate dielectric materials are used. The superlattice 25 may advantageously provide reduced scattering and, thus, enhanced mobility with respect to prior art insulation layers (e.g., silicon oxides) typically used for high-K dielectric interfaces. Moreover, use of the superlattice 25 as an insulator for applications with high-K dielectrics may result in smaller overall thicknesses, and thus improved device capacitance. This is because the superlattice 25 may be formed in relatively small thicknesses yet still provide desired insulating properties, as discussed further in co-pending U.S. Application Serial No. 11/136,881, which is assigned to the present Assignee and is hereby incorporated herein in its entirety by reference.

[0041] Applicants have identified improved materials or structures for the channel region of the MOSFET 20. More specifically, the Applicants have identified materials or structures having energy band structures for which the appropriate conductivity effective masses for electrons and/or holes are substantially less than the corresponding values for silicon.

[0042] Referring now additionally to FIGS. 2 and 3, the materials or structures are in the form of a superlattice 25 whose structure is controlled at the atomic or molecular level and may be formed using known techniques of atomic or molecular layer deposition. The superlattice 25 includes a plurality of layer groups 45a-45n arranged in stacked relation, as perhaps best understood with specific reference to the schematic cross-sectional view of FIG. 2. Moreover, an intermediate annealing process as described in co-pending U.S.

Application Serial No. 11/136,834, which is assigned to the present Assignee and is hereby incorporated herein in its entirety by reference, may also be used to advantageously reduce defects and provide smoother layer surfaces during fabrication.

[0043] Each group of layers 45a-45n of the superlattice 25 illustratively includes a plurality of stacked base semiconductor monolayers 46 defining a respective base semiconductor portion 46a-46n and an energy band-modifying layer 50 thereon. The energy band-modifying layers 50 are indicated by stippling in FIG. 2 for clarity of explanation.

[0044] The energy-band modifying layer 50 illustratively comprises one non-semiconductor monolayer constrained within a crystal lattice of adjacent base semiconductor portions. That is, opposing base semiconductor monolayers 46 in adjacent groups of layers 45a-45n are chemically bound together. For example, in the case of silicon monolayers 46, some of the silicon atoms in the upper or top semiconductor monolayer of the group of monolayers 46a will be covalently bonded with silicon atoms in the lower or bottom monolayer of the group 46b, as seen in FIG. 3. This allows the crystal lattice to continue through the groups of layers despite the presence of the non-semiconductor monolayer(s) (e.g., oxygen monolayer(s)). Of course, there will not be a complete or pure covalent bond between the opposing silicon layers 46 of adjacent groups 45a-45n as some of the silicon atoms in each of these layers will be bonded to non-semiconductor atoms (i.e., oxygen in the present



example), as will be appreciated by those skilled in the art.

[0045] In other embodiments, more than one such monolayer may be possible. It should be noted that reference herein to a non-semiconductor or semiconductor monolayer means that the material used for the monolayer would be a non-semiconductor or semiconductor if formed in bulk. That is, a single monolayer of a material, such as semiconductor, may not necessarily exhibit the same properties that it would if formed in bulk or in a relatively thick layer, as will be appreciated by those skilled in the art.

[0046] Applicants theorize without wishing to be bound thereto that energy band-modifying layers 50 and adjacent base semiconductor portions 46a-46n cause the superlattice 25 to have a lower appropriate conductivity effective mass for the charge carriers in the parallel layer direction than would otherwise be present. Considered another way, this parallel direction is orthogonal to the stacking direction. The band modifying layers 50 may also cause the superlattice 25 to have a common energy band structure.

[0047] It is also theorized that the semiconductor device, such as the illustrated MOSFET 20, enjoys a higher charge carrier mobility based upon the lower conductivity effective mass than would otherwise be present. In some embodiments, and as a result of the band engineering achieved by the present invention, the superlattice 25 may further have a substantially direct energy bandgap that may be particularly advantageous for opto-electronic devices, for example, as described in

further detail below. Of course, all of the above-described properties of the superlattice 25 need not be utilized in every application. For example, in some applications the superlattice 25 may only be used for its dopant blocking/insulation properties or its enhanced mobility, or it may be used for both in other applications, as will be appreciated by those skilled in the art.

[0048] In some embodiments, more than one non-semiconductor monolayer may be present in the energy band modifying layer 50. By way of example, the number of non-semiconductor monolayers in the energy band-modifying layer 50 may preferably be less than about five monolayers to thereby provide the desired energy band-modifying properties.

[0049] The superlattice 25 also illustratively includes a cap layer 52 on an upper layer group 45n. The cap layer 52 may comprise a plurality of base semiconductor monolayers 46. The cap layer 52 may have between 2 to 100 monolayers of the base semiconductor, and, more preferably between 10 to 50 monolayers.

[0050] Each base semiconductor portion 46a-46n may comprise a base semiconductor selected from the group consisting of Group IV semiconductors, Group III-V semiconductors, and Group II-VI semiconductors. Of course, the term Group IV semiconductors also includes Group IV-IV semiconductors as will be appreciated by those skilled in the art. More particularly, the base semiconductor may comprise at least one of silicon and germanium, for example.

[0051] Each energy band-modifying layer 50 may comprise a non-semiconductor selected from the group consisting of oxygen, nitrogen, fluorine, and carbon-oxygen, for example. The non-semiconductor is also desirably thermally stable through deposition of a next layer to thereby facilitate manufacturing. In other embodiments, the non-semiconductor may be another inorganic or organic element or compound that is compatible with the given semiconductor processing as will be appreciated by those skilled in the art.

[0052] It should be noted that the term monolayer is meant to include a single atomic layer and also a single molecular layer. It is also noted that the energy band-modifying layer 50 provided by a single monolayer is also meant to include a monolayer wherein not all of the possible sites are occupied, as noted above. For example, with particular reference to the atomic diagram of FIG. 3, a 4/1 repeating structure is illustrated for silicon as the base semiconductor material, and oxygen as the energy band-modifying material. Only half of the possible sites for oxygen are occupied.

[0053] In other embodiments and/or with different materials this one half occupation would not necessarily be the case, as will be appreciated by those skilled in the art. Indeed it can be seen even in this schematic diagram, that individual atoms of oxygen in a given monolayer are not precisely aligned along a flat plane as will also be appreciated by those of skill in the art of atomic deposition. By way of example, a preferred occupation range is from about one-eighth to one-half of

the possible oxygen sites being full, although other numbers may be used in certain embodiments.

[0054] Silicon and oxygen are currently widely used in conventional semiconductor processing, and, hence, manufacturers will be readily able to use these materials as described herein. Atomic or monolayer deposition is also now widely used. Accordingly, semiconductor devices incorporating the superlattice 25 may be readily adopted and implemented as will be appreciated by those skilled in the art.

[0055] It is theorized without Applicants wishing to be bound thereto that for a superlattice, such as the Si/O superlattice, for example, that the number of silicon monolayers should desirably be seven or less so that the energy band of the superlattice is common or relatively uniform throughout to achieve the desired advantages. Of course, more than seven silicon layers may be used in some embodiments. The 4/1 repeating structure shown in FIGS. 2 and 3, for Si/O has been modeled to indicate an enhanced mobility for electrons and holes in the X direction. For example, the calculated conductivity effective mass for electrons (isotropic for bulk silicon) is 0.26 and for the 4/1 SiO superlattice in the X direction it is 0.12 resulting in a ratio of 0.46. Similarly, the calculation for holes yields values of 0.36 for bulk silicon and 0.16 for the 4/1 Si/O superlattice resulting in a ratio of 0.44.

[0056] While such a directionally preferential feature may be desired in certain semiconductor devices, other devices may benefit from a more uniform increase in mobility in any direction parallel to the groups of

layers. It may also be beneficial to have an increased mobility for both electrons or holes, or just one of these types of charge carriers as will be appreciated by those skilled in the art.

[0057] The lower conductivity effective mass for the 4/1 Si/O embodiment of the superlattice 25 may be less than two-thirds the conductivity effective mass than would otherwise occur, and this applies for both electrons and holes. Of course, the superlattice 25 may further comprise at least one type of conductivity dopant therein as will also be appreciated by those skilled in the art. It may be especially appropriate to dope at least a portion of the superlattice 25 if the superlattice is to provide some or all of the channel. However, the superlattice 25 or portions thereof may also remain substantially undoped in some embodiments, as described further in U.S. Application Serial No. 11/136,757, which is assigned to the present Assignee and is hereby incorporated herein in its entirety by reference.

[0058] Referring now additionally to FIG. 4, another embodiment of a superlattice 25' in accordance with the invention having different properties is now described. In this embodiment, a repeating pattern of 3/1/5/1 is illustrated. More particularly, the lowest base semiconductor portion 46a' has three monolayers, and the second lowest base semiconductor portion 46b' has five monolayers. This pattern repeats throughout the superlattice 25'. The energy band-modifying layers 50' may each include a single monolayer. For such a superlattice 25' including Si/O, the enhancement of

charge carrier mobility is independent of orientation in the plane of the layers. Those other elements of FIG. 4 not specifically mentioned are similar to those discussed above with reference to FIG. 2 and need no further discussion herein.

[0059] In some device embodiments, all of the base semiconductor portions of a superlattice may be a same number of monolayers thick. In other embodiments, at least some of the base semiconductor portions may be a different number of monolayers thick. In still other embodiments, all of the base semiconductor portions may be a different number of monolayers thick.

[0060] In FIGS. 5A-5C band structures calculated using Density Functional Theory (DFT) are presented. It is well known in the art that DFT underestimates the absolute value of the bandgap. Hence all bands above the gap may be shifted by an appropriate "scissors correction." However, the shape of the band is known to be much more reliable. The vertical energy axes should be interpreted in this light.

[0061] FIG. 5A shows the calculated band structure from the gamma point (G) for both bulk silicon (represented by continuous lines) and for the 4/1 Si/O superlattice 25 as shown in FIGS. 1-3 (represented by dotted lines). The directions refer to the unit cell of the 4/1 Si/O structure and not to the conventional unit cell of Si, although the (001) direction in the figure does correspond to the (001) direction of the conventional unit cell of Si, and, hence, shows the expected location of the Si conduction band minimum. The (100) and (010) directions in the figure correspond to

the (110) and (-110) directions of the conventional Si unit cell. Those skilled in the art will appreciate that the bands of Si on the figure are folded to represent them on the appropriate reciprocal lattice directions for the 4/1 Si/O structure.

[0062] It can be seen that the conduction band minimum for the 4/1 Si/O structure is located at the gamma point in contrast to bulk silicon (Si), whereas the valence band minimum occurs at the edge of the Brillouin zone in the (001) direction which we refer to as the Z point. One may also note the greater curvature of the conduction band minimum for the 4/1 Si/O structure compared to the curvature of the conduction band minimum for Si owing to the band splitting due to the perturbation introduced by the additional oxygen layer.

[0063] FIG. 5B shows the calculated band structure from the Z point for both bulk silicon (continuous lines) and for the 4/1 Si/O superlattice 25 (dotted lines). This figure illustrates the enhanced curvature of the valence band in the (100) direction.

[0064] FIG. 5C shows the calculated band structure from the both the gamma and Z point for both bulk silicon (continuous lines) and for the 5/1/3/1 Si/O structure of the superlattice 25' of FIG. 4 (dotted lines). Due to the symmetry of the 5/1/3/1 Si/O structure, the calculated band structures in the (100) and (010) directions are equivalent. Thus the conductivity effective mass and mobility are expected to be isotropic in the plane parallel to the layers, i.e. perpendicular to the (001) stacking direction. Note that in the 5/1/3/1 Si/O example

the conduction band minimum and the valence band maximum are both at or close to the Z point.

[0065] Although increased curvature is an indication of reduced effective mass, the appropriate comparison and discrimination may be made via the conductivity reciprocal effective mass tensor calculation. This leads Applicants to further theorize that the 5/1/3/1 superlattice 25' should be substantially direct bandgap. As will be understood by those skilled in the art, the appropriate matrix element for optical transition is another indicator of the distinction between direct and indirect bandgap behavior.

[0066] Turning additionally to FIGS. 7-9, additional embodiments of MOSFETs 120, 220, and 320 each including a strained superlattice layer are now described. In the illustrated embodiments, the various layers and regions that are similar to those discussed above with reference to FIG. 1 are represented by increments of one hundred (e.g., the substrates 121, 221, and 321 shown in FIGS. 7-9, respectively, are similar to the substrate 21).

[0067] In the MOSFET 120, the stress layer is provided by a plurality of spaced apart strain inducing pillars 144 arranged in side-by-side relation on the backside (i.e., bottom) of the substrate 121. By way of example, if compressive strain is desired then the pillars 144 may include plasma enhanced chemical vapor deposition (PECVD) silicon nitride (SiN), metal, or other materials which become compressed upon or after being deposited in trenches etched in the backside of the substrate 121. Moreover, if tensile strain is desired then the pillars may include a thermally formed SiN material or low



pressure chemical vapor deposition (LPCVD) SiN material, for example. Of course, other suitable materials known to those skilled in the art may also be used. Further details on a backside strain-inducing pillar arrangement may be found in U.S. Patent Publication No. 2005/0263753 to Pelella et al., which is hereby incorporated herein in its entirety by reference.

[0068] Moreover, an insulating layer 143 (shown with stippling for clarity of illustration), such as an SiO<sub>2</sub> layer, may also be positioned between the stress layer 125 and the strained superlattice layer to provide a semiconductor-on-insulator embodiment, as shown, although the insulating layer need not be used in all embodiments. Further details on forming a superlattice structure as set forth above on a semiconductor-on-insulator substrate are provided in co-pending U.S. Application Serial No. 11/381,835, which is assigned to the present Assignee and is hereby incorporated herein in its entirety by reference. Of course, semiconductor-on-insulator implementations may be used in other embodiments discussed herein as well.

[0069] Referring to FIG. 8, in the MOSFET 220 the regions 327, 328 define a pair of spaced apart stress regions for inducing strain in the superlattice layer 125 positioned therebetween. More particularly, one or both of the stress regions may include a material that induces a desired strain on the superlattice layer 225. Using the above-noted example, for a silicon-oxygen superlattice layer 225 one or both of the regions 327, 328 may include silicon germanium. Yet, whereas in the MOSFET 20 the silicon germanium induced a tensile strain when

positioned below the superlattice layer 25, when positioned on one or both sides of the superlattice layer 225 the silicon germanium has the opposite effect and compresses the superlattice.

[0070] Thus, in the illustrated embodiment silicon germanium in the stress regions 227, 228 would be advantageous for P-channel implementations because it induces compressive strain. Alternatively, a tensile strain could advantageously be induced in the superlattice layer 225 for N-channel devices by properly selecting the composition of the superlattice and the stress regions 227, 228, as discussed above. It should be noted that in some embodiments the spaced apart stress regions 227, 228 need not include the same materials. That is, strain may be induced as one stress region "pushes" or "pulls" against the other which serves as an anchor.

[0071] In the above-described embodiment, the pair of stress regions 227, 228 are doped to provide the source and drain regions 222, 223. Moreover, the stress regions 227, 228 illustratively include canted surfaces or facets 245, 246 adjacent opposing portions of the strained superlattice. The canted surfaces 245, 246 may result from the etching process used to pattern the superlattice 225 so that the stress inducing material can be deposited adjacent thereto. However, the surfaces 245, 246 need not be canted in all embodiments. Further details on making strained channel devices with strain-inducing source and drain regions are disclosed in U.S. Patent No. 6,495,402 to Yu et al. and U.S. Patent Publication No. 2005/0142768

to Lindert et al., both of which are hereby incorporated herein in their entireties by reference.

[0072] Referring to FIG. 9, the MOSFET 320 illustratively includes a stress layer 347 above the strained superlattice layer 325. By way of example, the stress layer may be a SiN layer deposited over the source, drain, and gate regions of the MOSFET 320 that induces a strain in the underlying semiconductor material, including the superlattice layer 325. As noted above, a tensile or compressive nitride material may be used depending upon the type of strain desired in the superlattice layer 325. Of course, other suitable materials may also be used for the stress layer 347, and multiple stress layers may be used in some embodiments. Moreover, in certain embodiments the superlattice layer 325 may "memorize" the strain induced from the overlying stress layer 347, and the stress layer may thereafter be removed, as will be appreciated by those skilled in the art. Further details on creating strain in semiconductor regions using overlying stress layers may be found in U.S. Patent Publication Nos. 2005/0145894 to Chau et al. and 2005/0247926 to Sun et al., both of which are hereby incorporated herein in their entireties by reference.

[0073] A first method aspect in accordance with the invention for making a semiconductor device, such as the MOSFET 20, is now described. The method includes forming a stress layer 26, and forming a strained superlattice layer 25 above the stress layer. Another method aspect is for making a semiconductor device, such as the MOSFET 220, which includes forming a superlattice layer 225, and forming at least one pair of spaced apart stress regions

227, 228 on opposing sides of the superlattice layer to induce a strain therein. Still another method aspect is for making a semiconductor device, such as the MOSFET 320, which includes forming a superlattice layer 325, and forming a stress layer 347 above the strained superlattice layer to induce a strain therein. Various other method steps and aspects will be appreciated by those skilled in the art from the foregoing description and therefore require no further discussion herein.

[0074] It should be noted that in the above-described embodiments, the strained layer need not always be a superlattice 25. Rather, the strained layer may simply include a plurality of base semiconductor portions 46a-46n, and one or more non-semiconductor monolayers 50 constrained within a crystal lattice of adjacent base semiconductor portions (i.e., the adjacent base semiconductor portions are chemically bound together, as described above). In this embodiment, the base semiconductor portions 46a-46n need not include a plurality of semiconductor monolayers, i.e., each semiconductor portion could include a single layer or a plurality of monolayers, for example.

[0075] A MOSFET 80 illustratively including a non-semiconductor monolayer 81 is schematically shown in FIG. 10 wherein the semiconductor monolayers are in the portions 82a, 82b respectively below and above the non-semiconductor monolayer. The gate dielectric 83 is illustratively above the channel 85, and the gate electrode 84 is above the gate dielectric. The region between the lower portion of the gate dielectric 83 and the upper portion of the channel 85 define an interface

86. The source and drain (not shown) would be positioned laterally adjacent the channel 85, as will be appreciated by those skilled in the art.

[0076] The depth of the monolayer of non-semiconductor material 81 from the interface 86 may be selected based upon the MOSFET design, as will be appreciated by those skilled in the art. For example, a depth of about 4-100 monolayers, and more preferably a depth of about 4-30 monolayers, may be selected for a typical MOSFET 86 for an oxygen layer in a silicon channel. The at least one monolayer of non-semiconductor material may include one or more monolayers that are not fully populated in all of the available sites as described above.

[0077] As discussed above, the non-semiconductor may be selected from the group consisting of oxygen, nitrogen, fluorine, and carbon-oxygen, for example. The at least one monolayer of non-semiconductor material 81 may be deposited using atomic layer deposition techniques, for example, as also described above and as will be appreciated by those skilled in the art. Other deposition and/or implantation methods may also be used to form the channel 85 to include the at least one non-semiconductor material layer 81 within the crystal lattice of adjacent semiconductor layers 82a, 82b.

[0078] A simulated plot 90 of density at the interface versus depth of an oxygen layer in Angstroms is shown in FIG. 11. As will be appreciated by those skilled in the art, in embodiments such as the illustrated MOSFET 80, repeating groups of the superlattice need not be used, yet the at least one non-semiconductor monolayer 81 may still provide enhancement to mobility. In addition,

Applicants also theorize without wishing to be bound thereto that these embodiments will also have lower tunneling gate leakage as a result of the reduced magnitude of the wave functions at the interface 86. It is also theorized that further desirable features of these embodiments include increased energy separation between sub-bands, and the spatial separation of sub-bands, thereby reducing sub-band scattering.

[0079] Of course in other embodiments, the at least one monolayer 81 may also be used in combination with an underlying superlattice as will also be appreciated by those skilled in the art. Further, many modifications and other embodiments of the invention will come to the mind of one skilled in the art having the benefit of the teachings presented in the foregoing descriptions and the associated drawings. Therefore, it is understood that the invention is not to be limited to the specific embodiments disclosed, and that modifications and embodiments are intended.

**THAT WHICH IS CLAIMED IS:**

1. A semiconductor device comprising:  
at least one pair of spaced apart stress regions; and  
a strained superlattice layer between said at least one pair of spaced apart stress regions and comprising a plurality of stacked groups of layers;  
each group of layers of said strained superlattice layer comprising a plurality of stacked base semiconductor monolayers defining a base semiconductor portion and at least one non-semiconductor monolayer constrained within a crystal lattice of adjacent base semiconductor portions.
2. The semiconductor device of Claim 1 wherein said at least one pair of spaced apart stress regions comprises at least one pair of source and drain regions.
3. The semiconductor device of Claim 1 wherein at least one of said stress regions has a canted surface adjacent opposing portions of said strained superlattice.
4. The semiconductor device of Claim 1 wherein at least one of said stress regions comprises silicon and germanium.
5. The semiconductor device of Claim 1 further comprising a semiconductor substrate below said at least one pair of spaced apart stress regions and said strained superlattice layer.
6. The semiconductor device of Claim 1 wherein said strained superlattice layer has a compressive strain.

7. The semiconductor device of Claim 1 wherein said strained superlattice layer has a tensile strain.

8. The semiconductor device of Claim 1 wherein each base semiconductor portion comprises a base semiconductor selected from the group consisting of Group IV semiconductors, Group III-V semiconductors, and Group II-VI semiconductors.

9. The semiconductor device of Claim 1 wherein each non-semiconductor monolayer comprises a non-semiconductor selected from the group consisting of oxygen, nitrogen, fluorine, and carbon-oxygen.

10. The semiconductor device of Claim 1 wherein adjacent base semiconductor portions are chemically bound together.

11. The semiconductor device of Claim 1 wherein each non-semiconductor monolayer is a single monolayer thick.

12. The semiconductor device of Claim 1 wherein each base semiconductor portion is less than eight monolayers thick.

13. The semiconductor device of Claim 1 wherein said strained superlattice layer further comprises a base semiconductor cap layer on an uppermost group of layers.

14. A semiconductor device comprising:  
at least one pair of spaced apart stress regions; and

a strained layer between said at least one pair of spaced apart stress regions and comprising a plurality of stacked base semiconductor portions and at least one



non-semiconductor monolayer constrained within a crystal lattice of adjacent base semiconductor portions.

15. The semiconductor device of Claim 14 wherein said at least one pair of spaced apart stress regions comprises at least one pair of source and drain regions.

16. The semiconductor device of Claim 14 wherein at least one of said stress regions has a canted surface adjacent opposing portions of said strained layer.

17. The semiconductor device of Claim 14 wherein at least one of said stress regions comprises silicon and germanium.

18. The semiconductor device of Claim 14 wherein adjacent base semiconductor portions are chemically bound together.

19. A method for making a semiconductor device comprising:

forming a superlattice layer comprising a plurality of stacked groups of layers; and

forming at least one pair of spaced apart stress regions on opposing sides of the superlattice layer to induce a strain therein;

each group of layers of the strained superlattice layer comprising a plurality of stacked base semiconductor monolayers defining a base semiconductor portion and at least one non-semiconductor monolayer constrained within a crystal lattice of adjacent base semiconductor portions.

20. The method of Claim 19 wherein the at least one pair of spaced apart stress regions comprises at least one pair of source and drain regions.

21. The method of Claim 19 wherein at least one of the stress regions has a canted surface adjacent opposing portions of the superlattice layer.

22. The method of Claim 19 wherein at least one of the stress regions comprises silicon and germanium.

23. The method of Claim 19 wherein each base semiconductor portion comprises a base semiconductor selected from the group consisting of Group IV semiconductors, Group III-V semiconductors, and Group II-VI semiconductors; and wherein each non-semiconductor monolayer comprises a non-semiconductor selected from the group consisting of oxygen, nitrogen, fluorine, and carbon-oxygen.

24. The method of Claim 19 wherein adjacent base semiconductor portions are chemically bound together.

25. A method for making a semiconductor device comprising:

forming a strain layer comprising a plurality of stacked base semiconductor portions and at least one non-semiconductor monolayer constrained within a crystal lattice of adjacent base semiconductor portions; and

forming at least one pair of spaced apart stress regions on opposing sides of the strain layer to induce a strain therein.

26. The method of Claim 25 wherein the at least one pair of spaced apart stress regions comprises at least one pair of source and drain regions.

27. The method of Claim 25 wherein at least one of the stress regions has a canted surface adjacent opposing portions of the strain layer.

28. The method of Claim 25 wherein at least one of the stress regions comprises silicon and germanium.

29. The method of Claim 25 wherein adjacent base semiconductor portions are chemically bound together.



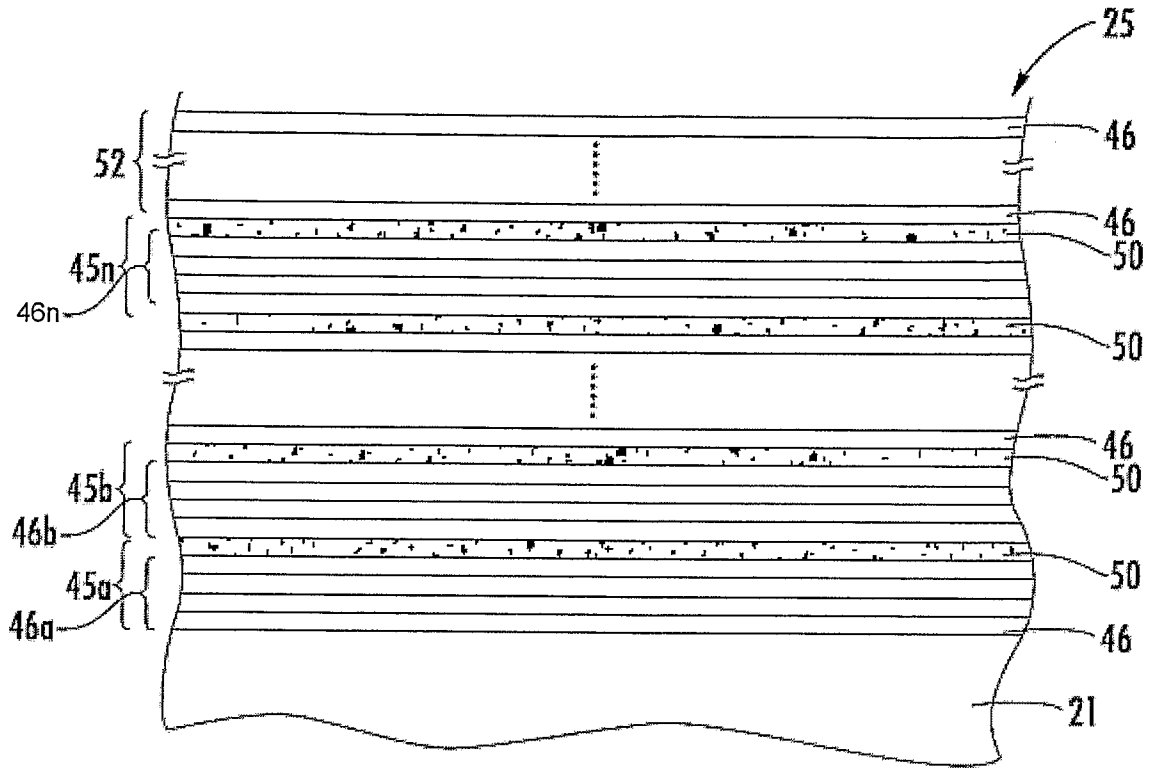
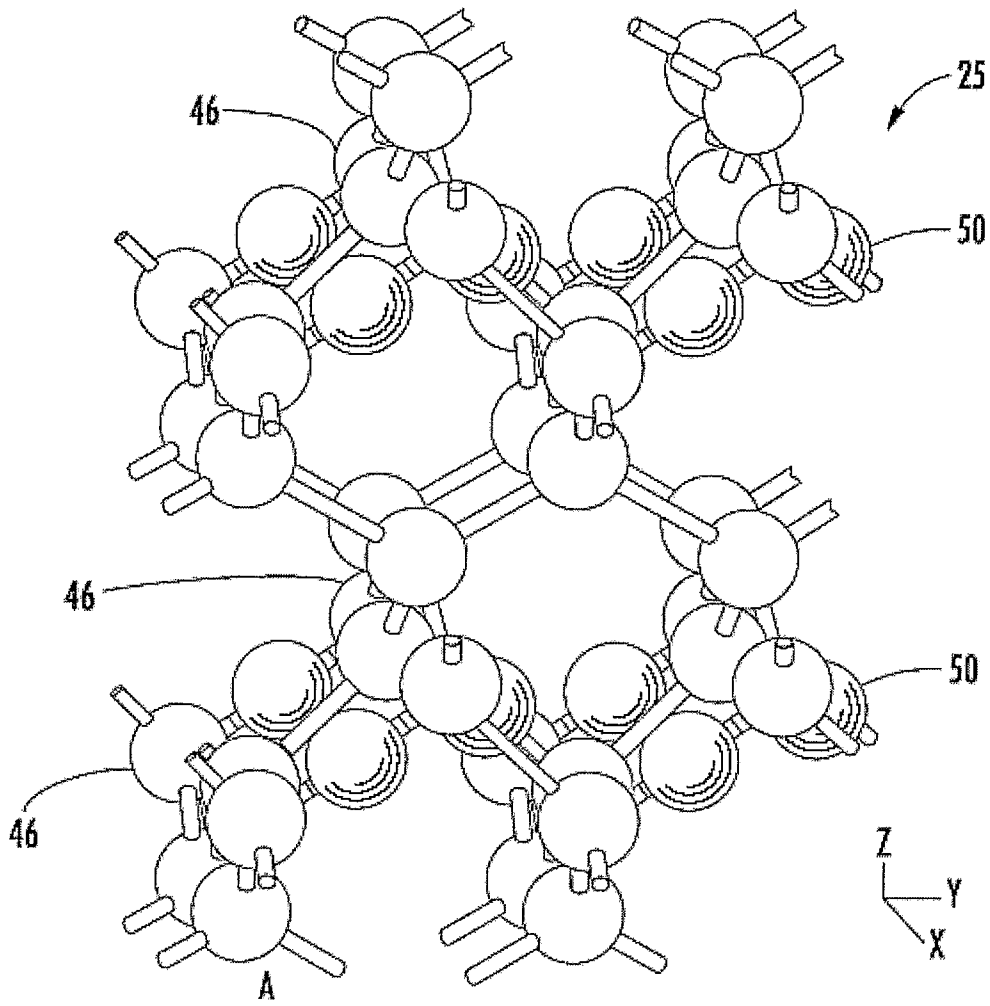

FIG. 2



**FIG. 3**

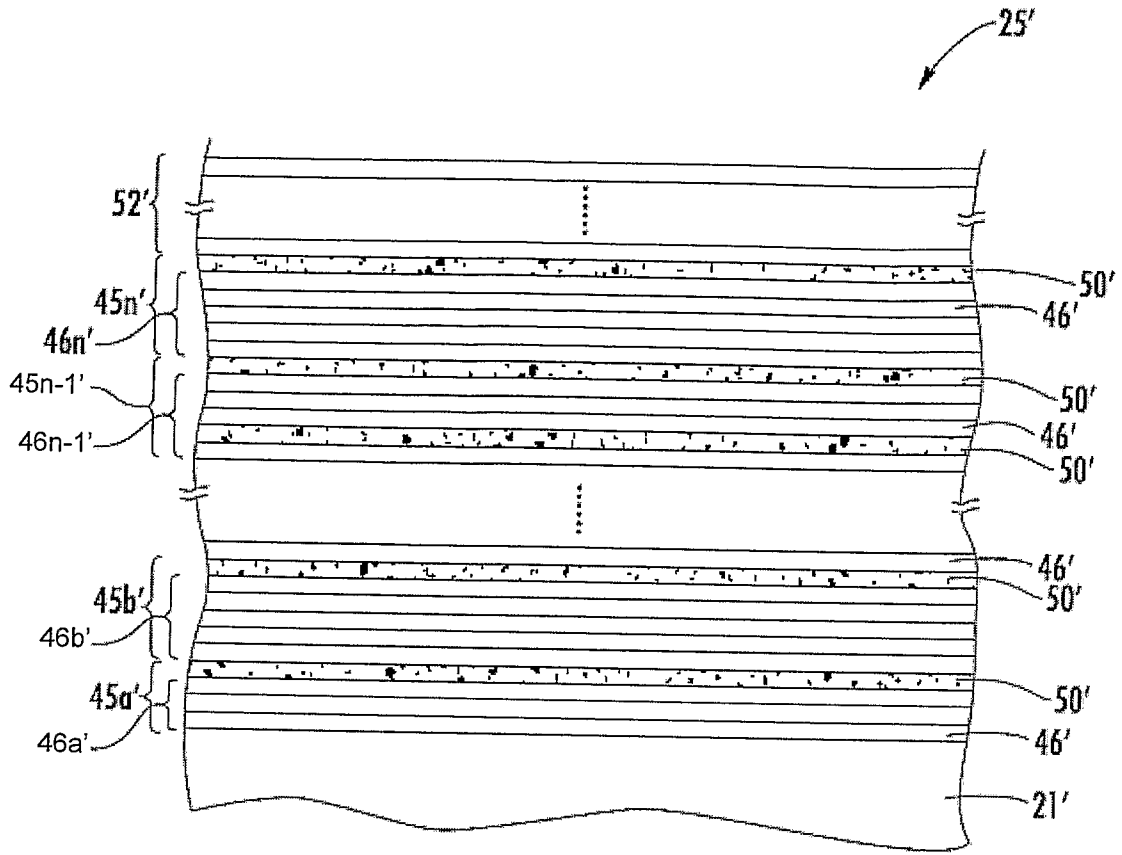
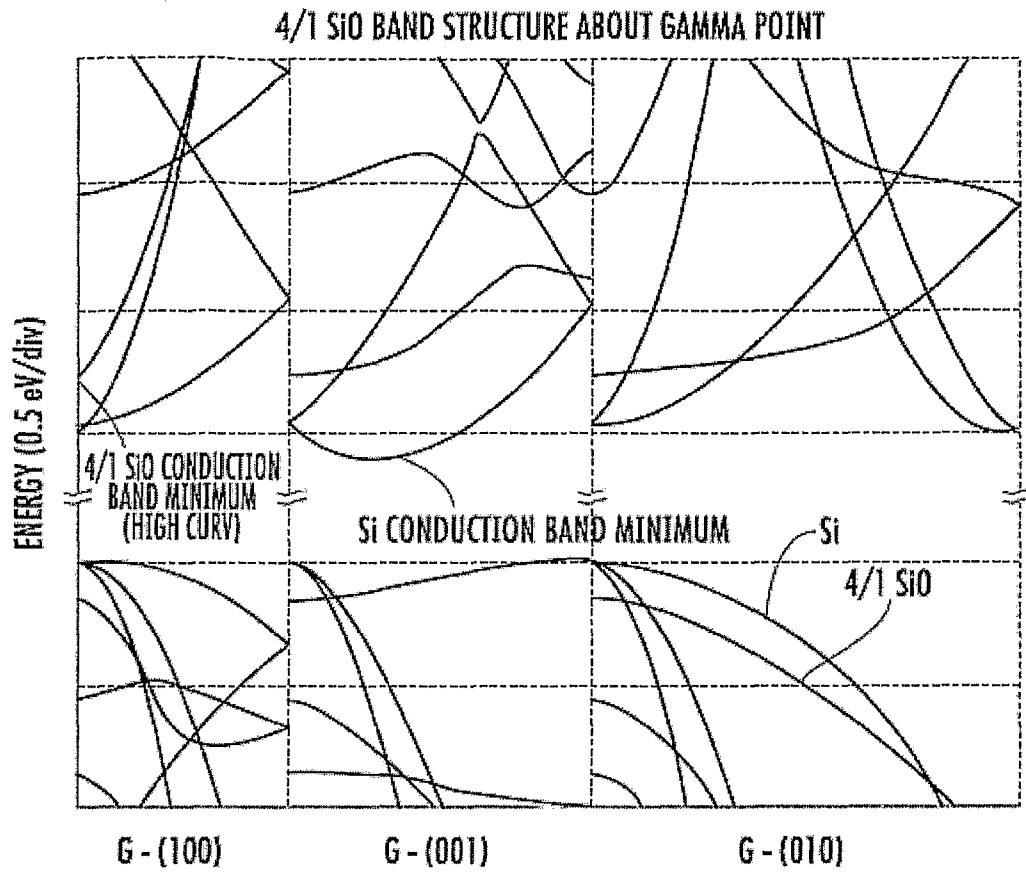
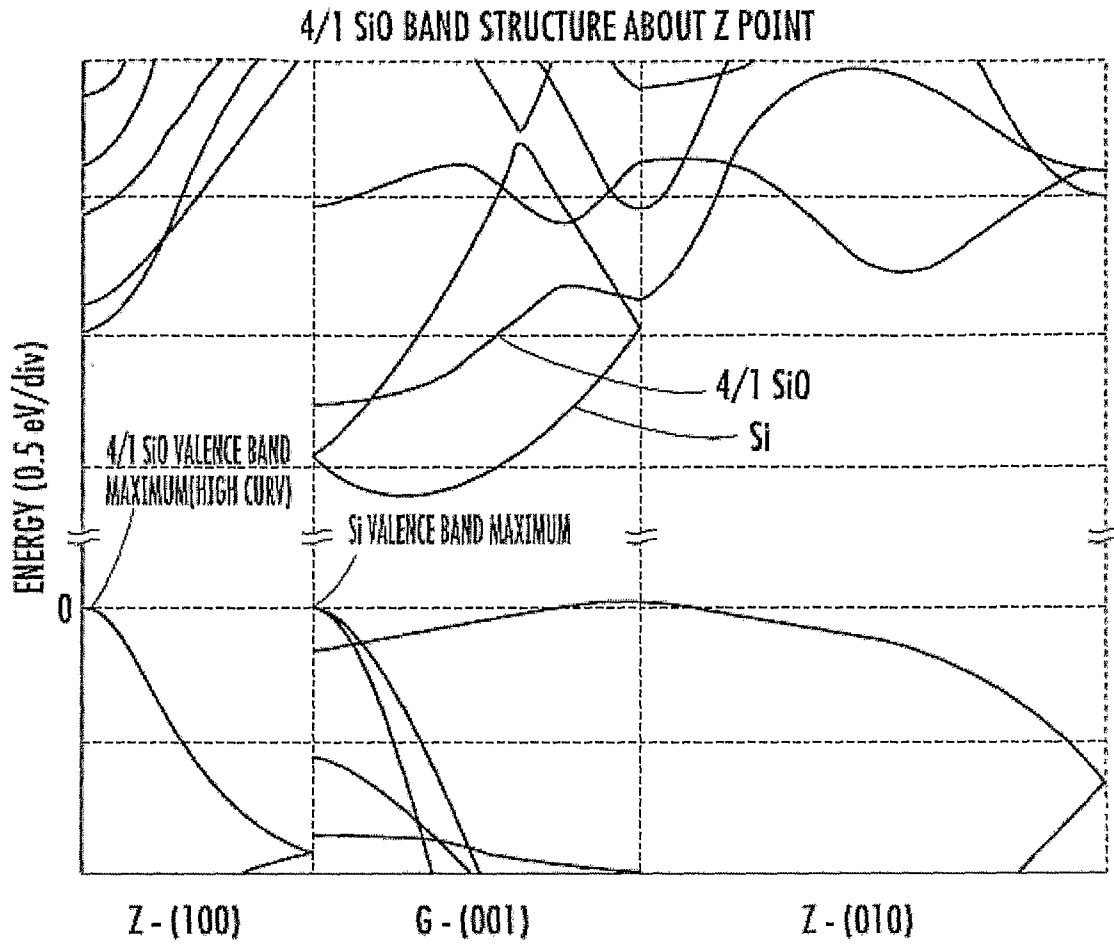

FIG. 4

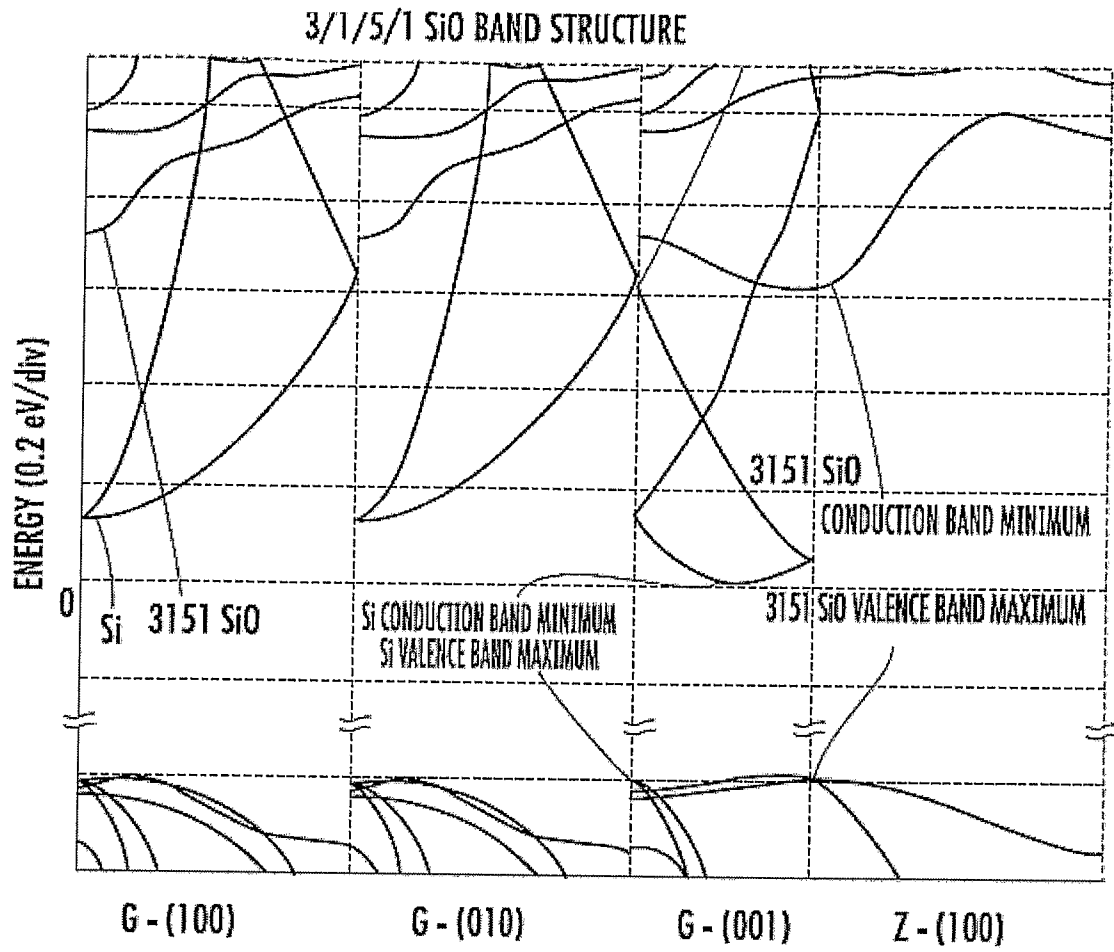

**FIG. 5A**





**FIG. 5B**



**FIG. 5C**

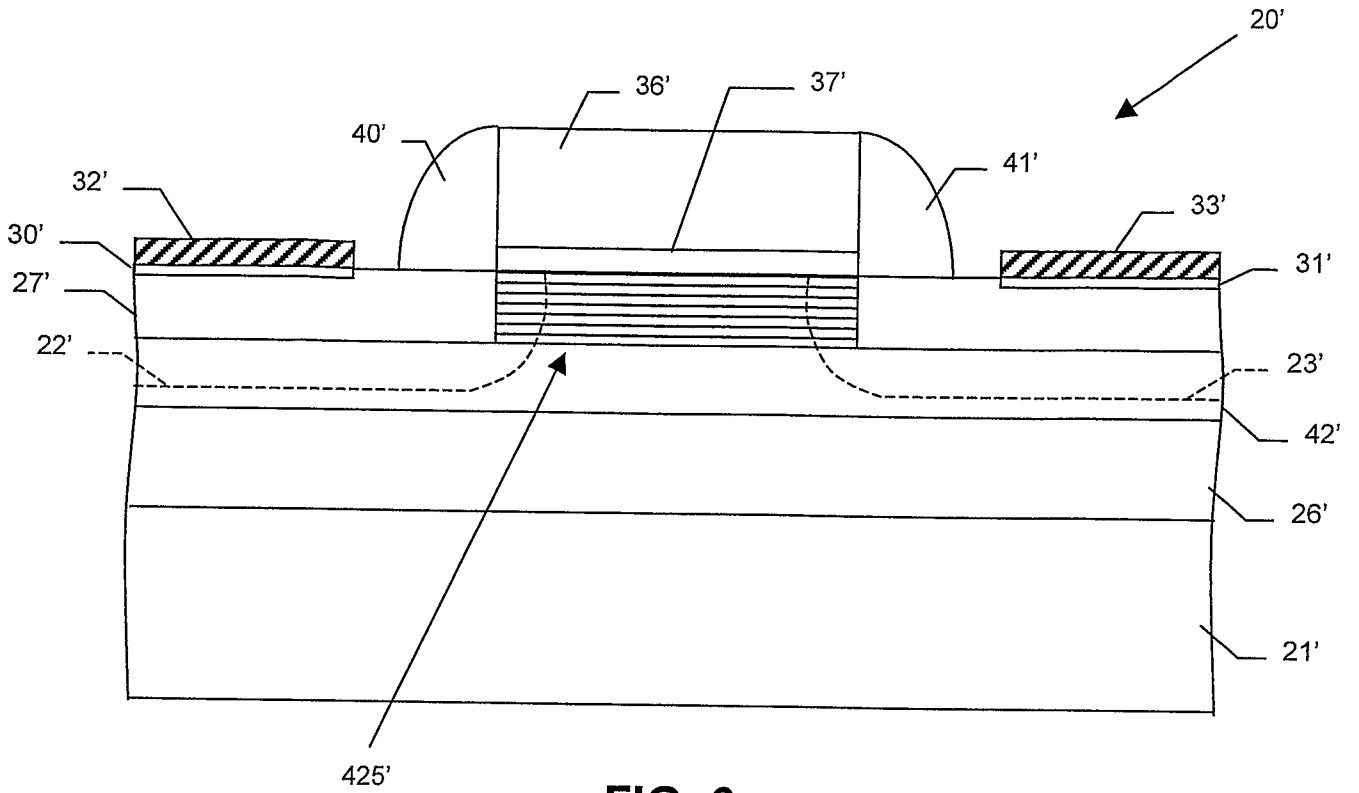

FIG. 6

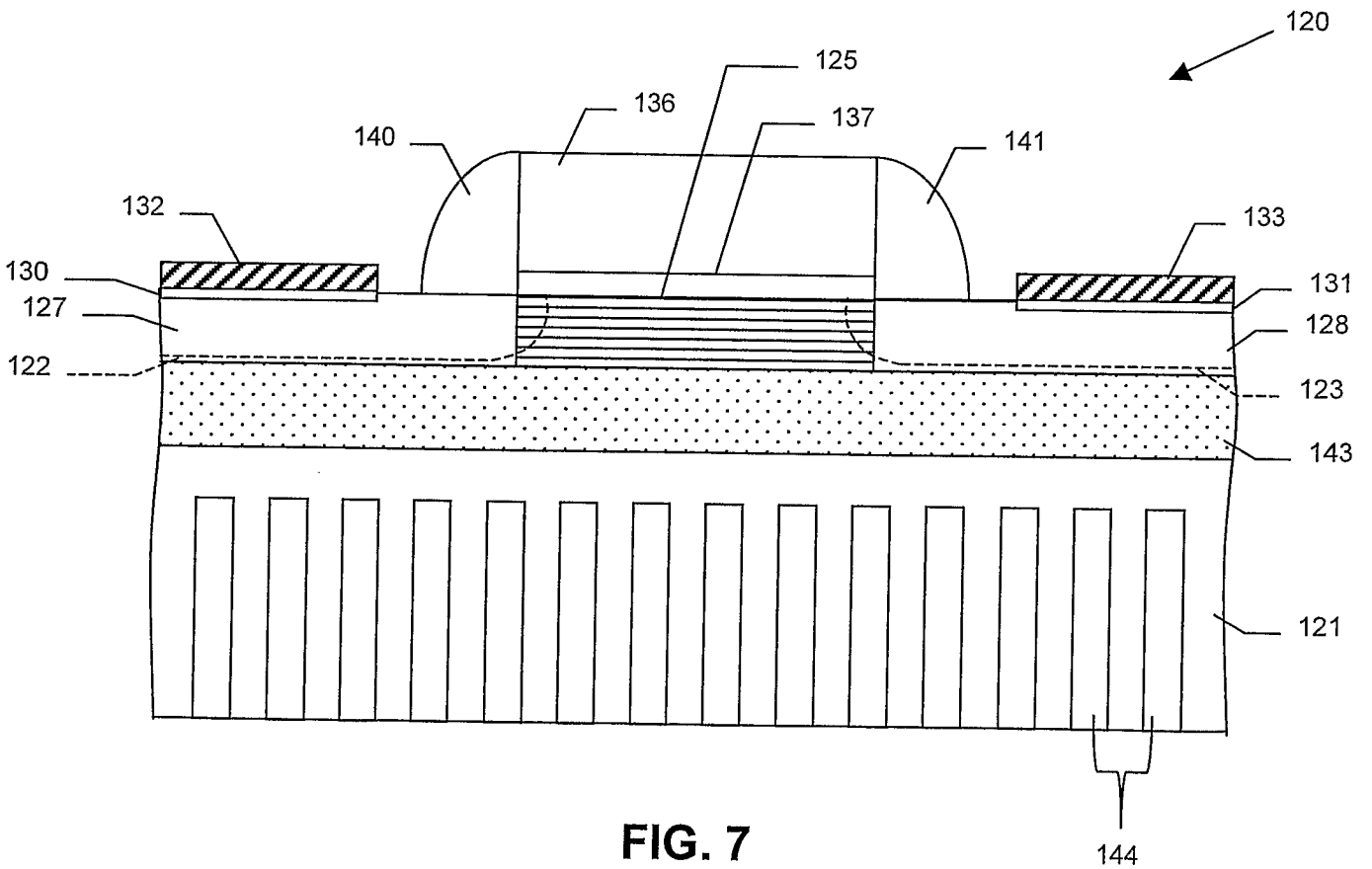

FIG. 7

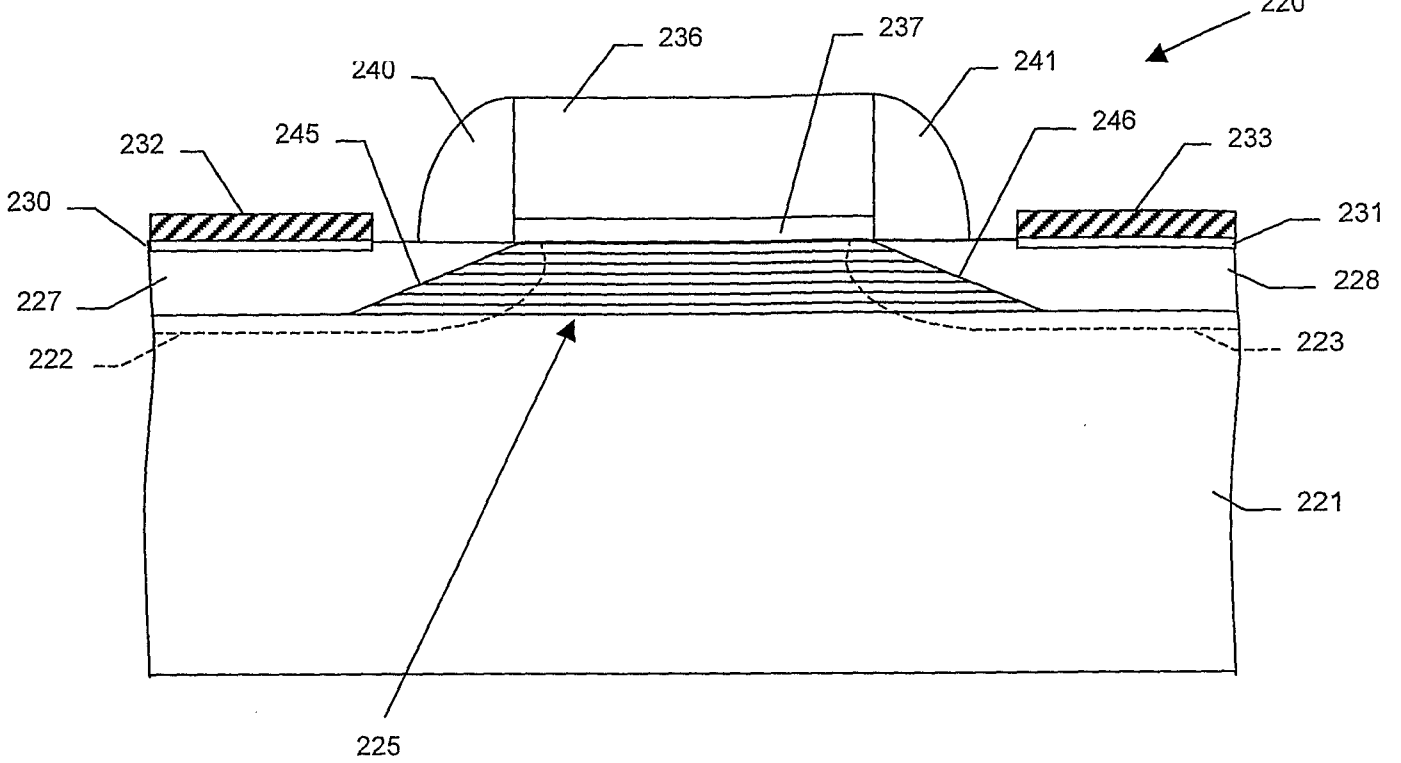

FIG. 8

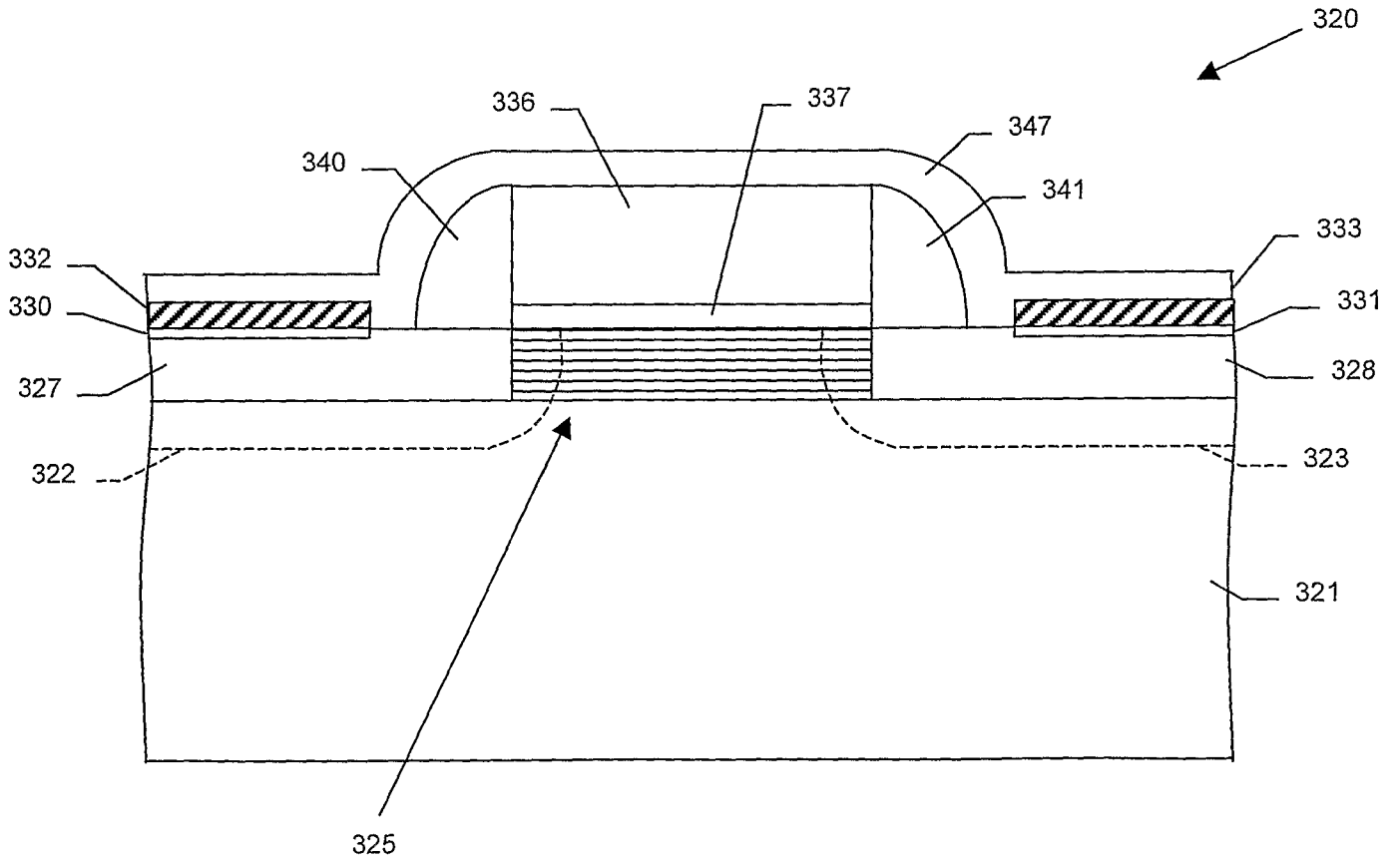

FIG. 9

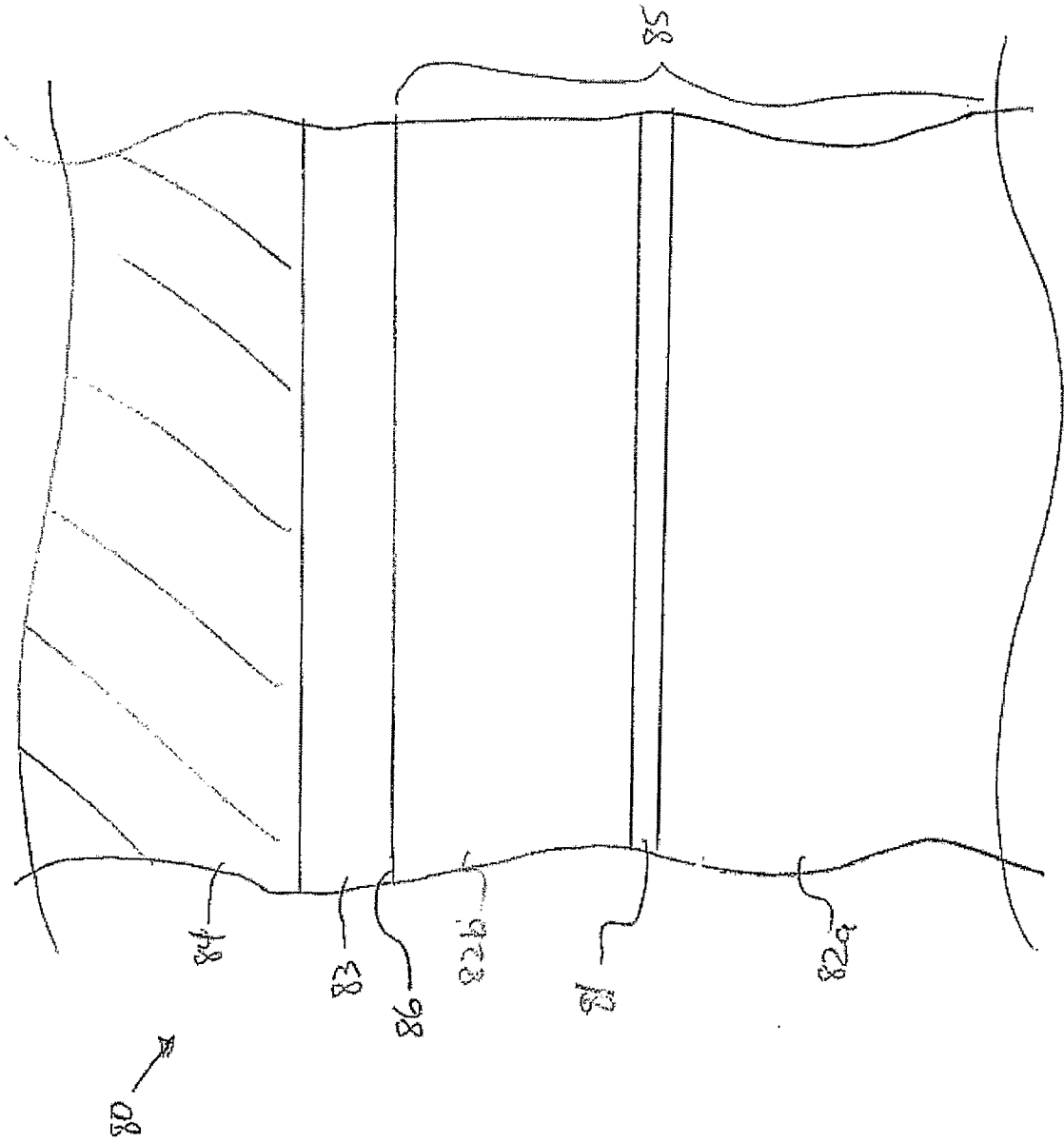

FIG. 10

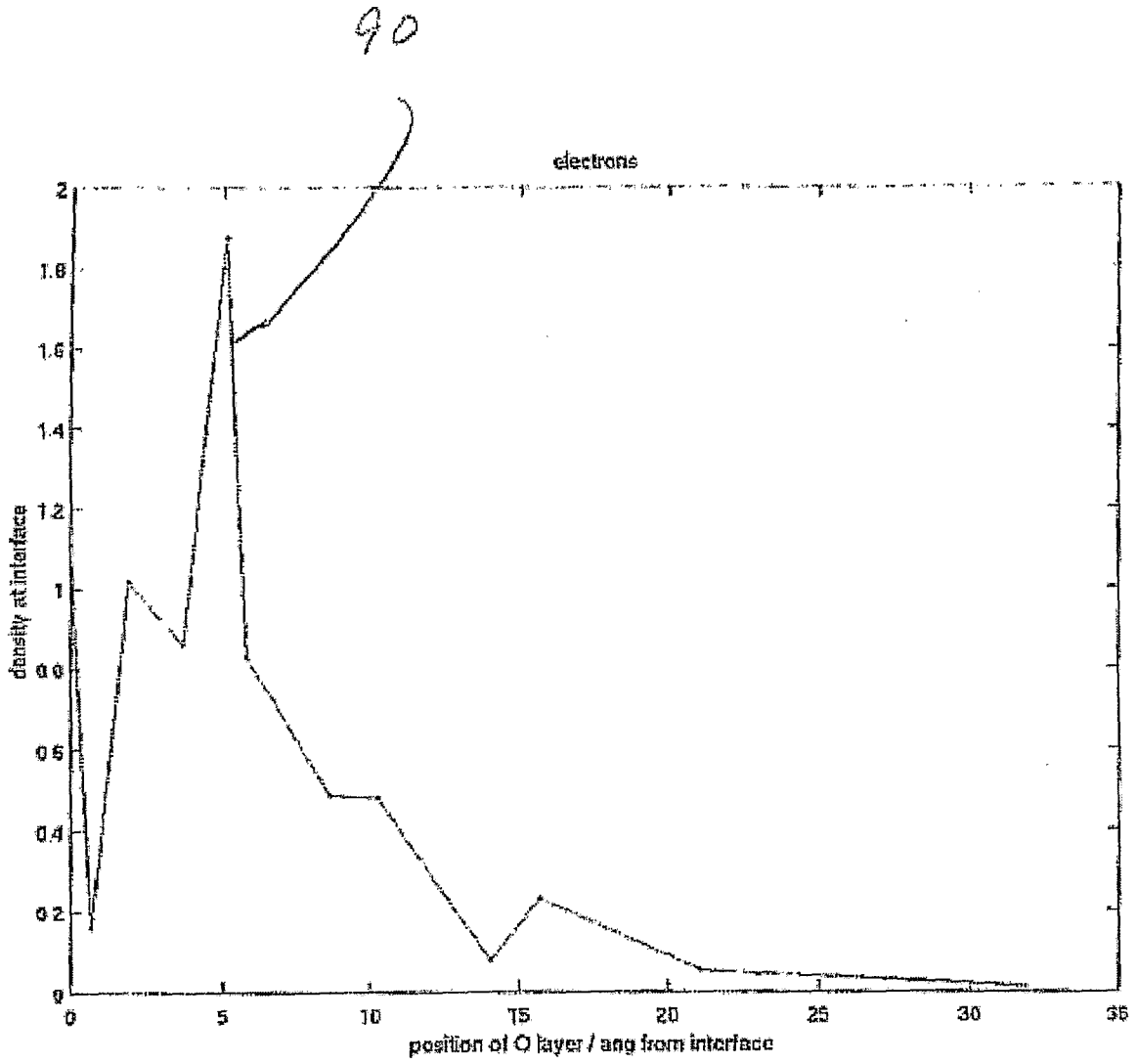

FIG. 11

## INTERNATIONAL SEARCH REPORT

International application No  
PCT/US2006/027503

A. CLASSIFICATION OF SUBJECT MATTER  
INV. H01L29/15 H01L29/10 H01L21/336 H01L21/8234

According to International Patent Classification (IPC) or to both national classification and IPC

## B. FIELDS SEARCHED

Minimum documentation searched (classification system followed by classification symbols)  
H01L

Documentation searched other than minimum documentation to the extent that such documents are included in the fields searched

Electronic data base consulted during the international search (name of data base and, where practical, search terms used)

EPO-Internal

## C. DOCUMENTS CONSIDERED TO BE RELEVANT

Category*	Citation of document, with indication, where appropriate, of the relevant passages	Relevant to claim No.
Y	US 2004/266045 A1 (MEARS ROBERT J [US] ET AL MEARS ROBERT J [US] ET AL) 30 December 2004 (2004-12-30) paragraphs [0013] - [0017], [0036] - [0042], [0049]; claims	1-29
Y	US 2005/142768 A1 (LINDERT NICK [US] ET AL) 30 June 2005 (2005-06-30) abstract paragraph [0013]; figures 2b,2c	1-29
A	WO 2005/013371 A2 (RJ MEARS LLC [US]; MEARS ROBERT J [US]; YIPTONG JEAN AUGUSTIN CHAN SOW) 10 February 2005 (2005-02-10) paragraphs [0029] - [0050]; figures	1-29
	----- -/--	

Further documents are listed in the continuation of Box C.

See patent family annex.

## \* Special categories of cited documents :

- \*A\* document defining the general state of the art which is not considered to be of particular relevance
- \*E\* earlier document but published on or after the international filing date
- \*L\* document which may throw doubts on priority claim(s) or which is cited to establish the publication date of another citation or other special reason (as specified)
- \*O\* document referring to an oral disclosure, use, exhibition or other means
- \*P\* document published prior to the international filing date but later than the priority date claimed

- \*T\* later document published after the international filing date or priority date and not in conflict with the application but cited to understand the principle or theory underlying the invention
- \*X\* document of particular relevance; the claimed invention cannot be considered novel or cannot be considered to involve an inventive step when the document is taken alone
- \*Y\* document of particular relevance; the claimed invention cannot be considered to involve an inventive step when the document is combined with one or more other such documents, such combination being obvious to a person skilled in the art.
- \* & \* document member of the same patent family

Date of the actual completion of the international search

12 October 2006

Date of mailing of the international search report

10/11/2006

Name and mailing address of the ISA/

European Patent Office, P.B. 5818 Patentlaan 2  
NL - 2280 HV Rijswijk  
Tel. (+31-70) 340-2040, Tx. 31 651 epo nl,  
Fax: (+31-70) 340-3016

Authorized officer

Ott, André

## INTERNATIONAL SEARCH REPORT

International application No  
PCT/US2006/027503

C(Continuation). DOCUMENTS CONSIDERED TO BE RELEVANT

Category*	Citation of document, with indication, where appropriate, of the relevant passages	Relevant to claim No.
A	US 2004/262683 A1 (BOHR MARK T [US] ET AL) 30 December 2004 (2004-12-30)  paragraphs [0022] - [0024]; figures -----	1-4, 6, 14-17, 19-22, 25-28



## INTERNATIONAL SEARCH REPORT

Information on patent family members

International application No

PCT/US2006/027503

Patent document cited in search report		Publication date	Patent family member(s)	Publication date
US 2004266045	A1	30-12-2004	US 2004262595 A1 US 2004262597 A1	30-12-2004 30-12-2004
US 2005142768	A1	30-06-2005	NONE	
WO 2005013371	A2	10-02-2005	AU 2004301905 A1 AU 2004306355 A1 CA 2530050 A1 CA 2530067 A1 EP 1644981 A2 EP 1644984 A1 US 2005170591 A1 US 2005167653 A1 US 2005167649 A1 US 2005170590 A1 US 2006019454 A1 US 2005282330 A1 US 2005279991 A1 US 2005272239 A1 US 2006011905 A1 US 2004262596 A1 US 2004262628 A1 US 2005017235 A1 US 2005087736 A1 US 2005087738 A1 WO 2005034245 A1	10-02-2005 14-04-2005 10-02-2005 14-04-2005 12-04-2006 12-04-2006 04-08-2005 04-08-2005 04-08-2005 04-08-2005 26-01-2006 22-12-2005 22-12-2005 08-12-2005 19-01-2006 30-12-2004 30-12-2004 27-01-2005 28-04-2005 28-04-2005 14-04-2005
US 2004262683	A1	30-12-2004	AU 2003297139 A1 CN 1577890 A EP 1639636 A1 WO 2005010982 A1	14-02-2005 09-02-2005 29-03-2006 03-02-2005