

(No Model.)

J. E. McINTOSH.
CENTRIFUGAL GOVERNOR.

No. 346,302.

Patented July 27, 1886.

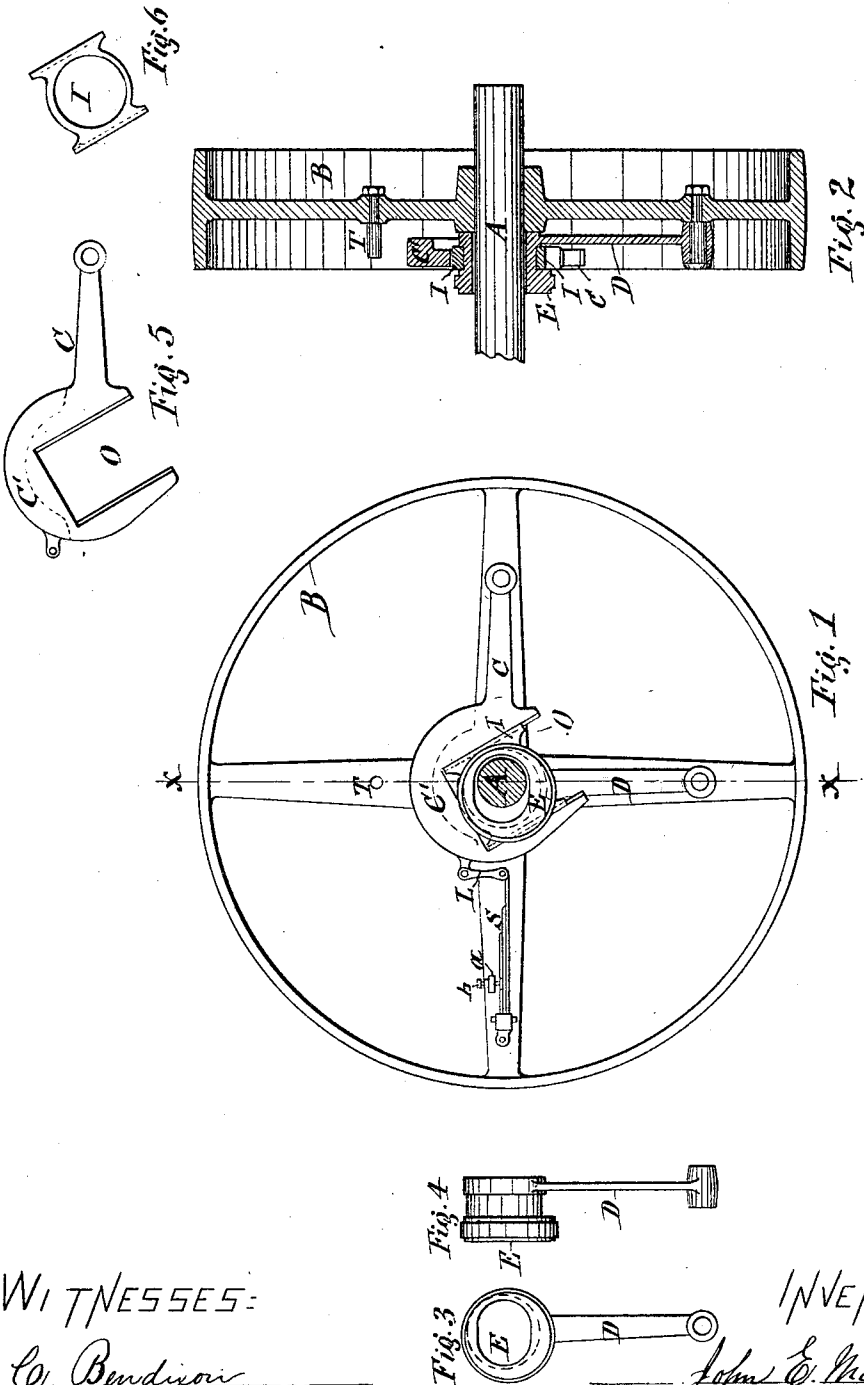

WITNESSES:

C. Bendixon
A. F. Walz

INVENTOR:

John E. McIntosh
per Clerk, L. S. & M. W.
his Atty.

UNITED STATES PATENT OFFICE.

JOHN E. MCINTOSH, OF CAYUGA, NEW YORK.

CENTRIFUGAL GOVERNOR.

SPECIFICATION forming part of Letters Patent No. 346,302, dated July 27, 1886.

Application filed April 26, 1886. Serial No. 200,170. (No model.)

To all whom it may concern:

Be it known that I, JOHN E. MCINTOSH, of Cayuga, in the county of Cayuga, in the State of New York, have invented new and useful
5 Improvements in Centrifugal Governors, of which the following, taken in connection with the accompanying drawings, is a full, clear, and exact description.

This invention has reference to the class of
10 centrifugal governors in which the eccentric is arranged movable diametrically or laterally on the driving-shaft of the engine and carried toward and from concentricity by a movable support, which is connected with the fly-
15 wheel, and is actuated by centrifugal force received from the fly-wheel while in motion.

The invention consists in a materially-simplified construction and combination of the constituent parts of the governor, as herein-
20 after described, and specifically set forth in the claims.

The invention is fully illustrated in the annexed drawings, wherein Figure 1 is a side view of my improved governor. Fig. 2 is a
25 transverse section on line *x x*, Fig. 1. Figs. 3 and 4 are detached face and side views of the eccentric; and Figs. 5 and 6 are detached face views of the arm which guides the eccentric, and of the box by which the eccentric
30 slides in the guide of the said arm.

Similar letters of reference indicate corresponding parts.

A represents the driving-shaft of an engine, and B the fly-wheel or driving-pulley, mounted
35 on said shaft in the usual and well-known manner.

C is an arm, which is pivoted on the side of the wheel B, and has its free end extended toward the shaft, and provided with a weighted
40 head, C', which is provided with a slot, O, by which the free end of the arm C strides the shaft A. In the slot O slides a box, I, and in this box is carried the eccentric E, which is attached to the free end of an arm, D, pivoted
45 on the side of the wheel B in a position at right angles to the arm C. The guide-slot O is arranged in a line at an angle in relation to the arms C D, and consequently said guide-slot crowds the eccentric E toward a concentric
50 position with the shaft when the free end of the arm C is swung from the center of the

wheel, which movement is effected by the centrifugal force exerted on the weighted arm by the wheel when in motion. The free end of the arm C is held normally at the center of
55 the wheel, and thus the eccentric is normally in its extreme eccentric position by the action of a spring, S, which is at one end connected to the wheel, and at the opposite end connected with the head C' or free end of the arm
60 C by a link, L. A lug, *a*, is rigidly attached to the wheel and provided with a screw-threaded eye, through which is extended a set-screw, *b*, and the end of the latter bears on the spring S. By turning this screw it is made
65 to press with greater or less force on the spring, and thus the tension of the latter can be adjusted to exert the desired resistance to the movement of the arm C under the influence of the centrifugal force.

T denotes a lug or pin, which projects from the side of the wheel in such a position as to
70 arrest the movement of the arm C in case of accidental uncoupling of the spring S from said arm.

Having described my invention, what I claim as new, and desire to secure by Letters
75 Patent, is—

1. In combination with the rotary shaft and wheel mounted thereon, two oscillatory arms
80 on the wheel, and having their free ends about the shaft, a guide-head on the free end of one of said arms, and an eccentric on the other arm and supported movably in the aforesaid guide-head, as set forth.

2. In combination with the rotary shaft and wheel mounted thereon, two arms pivoted at
85 right angles to each other on the wheel, and having their free ends about the shaft, a head of the free end of one of said arms, provided with a guide-slot arranged in a line at an
90 angle in relation to the two arms, a spring forcing the free ends of the said arms toward the center of the wheel, a box sliding in said slot, and an eccentric on the free end of the
95 other pivoted arm and carried in said box, substantially as described and shown.

3. In combination with the shaft A and wheel B, the arm C, pivoted on the wheel, and having its free end provided with the slotted
100 head C', astride the shaft, the box I, sliding in said slotted head, the arm D, pivoted on the

wheel at right angles to the arm C, the eccentric E on the free end of the arm D and carried in the box I, the spring S, attached to the wheel and to the free end of the arm C, and
5 the screw *b*, for adjusting the tension of said spring, substantially as described and shown.

In testimony whereof I have hereunto signed my name and affixed my seal, in the presence

of two attesting witnesses, at Syracuse, in the county of Onondaga, in the State of New York, 10 this 12th day of April, 1886.

JOHN E. MCINTOSH. [L. s.]

Witnesses:

FREDERICK H. GIBBS,
E. C. CANNON.