



(19) **United States**

(12) **Patent Application Publication**

(10) **Pub. No.: US 2004/0043160 A1**

Fusaro, JR. et al.

(43) **Pub. Date:**

Mar. 4, 2004

(54) **METHOD FOR COATING ARTICLES USING A PLASMA TRANSFERRED TORCH IN NON-TRANSFERRED MODE, AND RELATED METHODS FOR REPAIRING AND MANUFACTURING ARTICLES**

(52) **U.S. Cl.** 427/446; 427/449; 427/456

(57) **ABSTRACT**

(75) **Inventors:** Robert Anthony Fusaro JR., Schenectady, NY (US); Harvey Donald Solomon, Schenectady, NY (US)

A method for protecting an article from degradation, and a method for in-situ repair of a component of an assembly are presented, wherein the method for protecting comprises providing a substrate; providing a Plasma Transferred Arc (PTA) apparatus; setting the PTA apparatus to operate in a non-transferred arc mode; and disposing at least one coating on the substrate using the PTA apparatus in the non-transferred arc mode. The method for in-situ repair comprises providing a substrate, the substrate comprising a component of an assembly and coupled to the assembly; providing a PTA apparatus; welding the substrate using the PTA apparatus in a transferred arc mode to form a welded region on the substrate; setting the PTA apparatus to operate in a non-transferred arc mode; and disposing at least one coating on the welded region of the substrate using the PTA apparatus in the non-transferred arc mode, wherein the PTA apparatus is operated using a pilot arc power supply to dispose the at least one coating.

Correspondence Address:

**GENERAL ELECTRIC COMPANY
GLOBAL RESEARCH CENTER
PATENT DOCKET RM. 4A59
PO BOX 8, BLDG. K-1 ROSS
NISKAYUNA, NY 12309 (US)**

(73) **Assignee:** General Electric Company, Niskayuna, NY (US)

(21) **Appl. No.:** 10/064,893

(22) **Filed:** Aug. 27, 2002

Publication Classification

(51) **Int. Cl.⁷** C23C 4/08

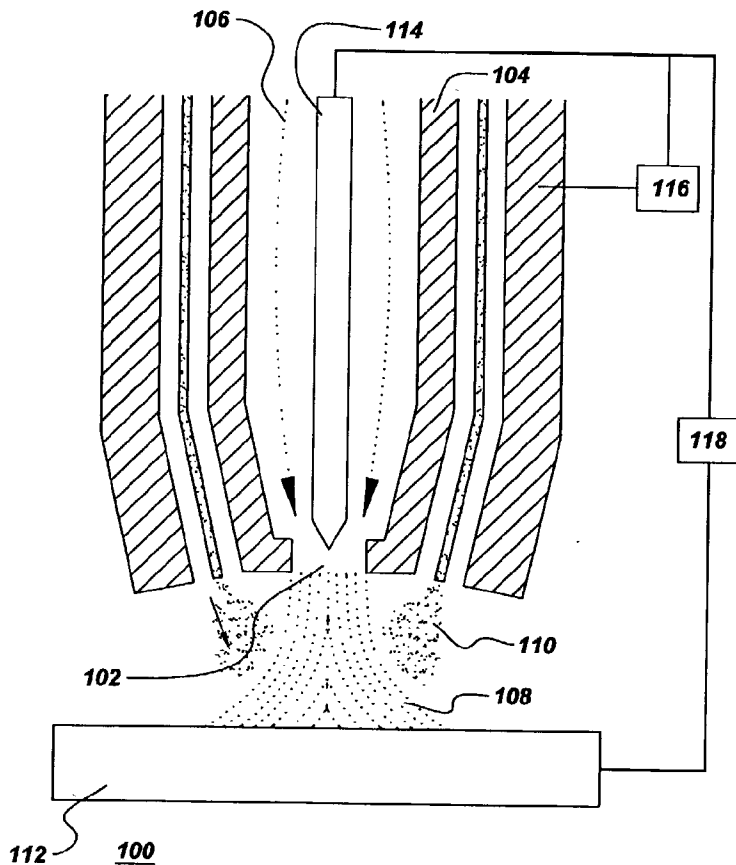

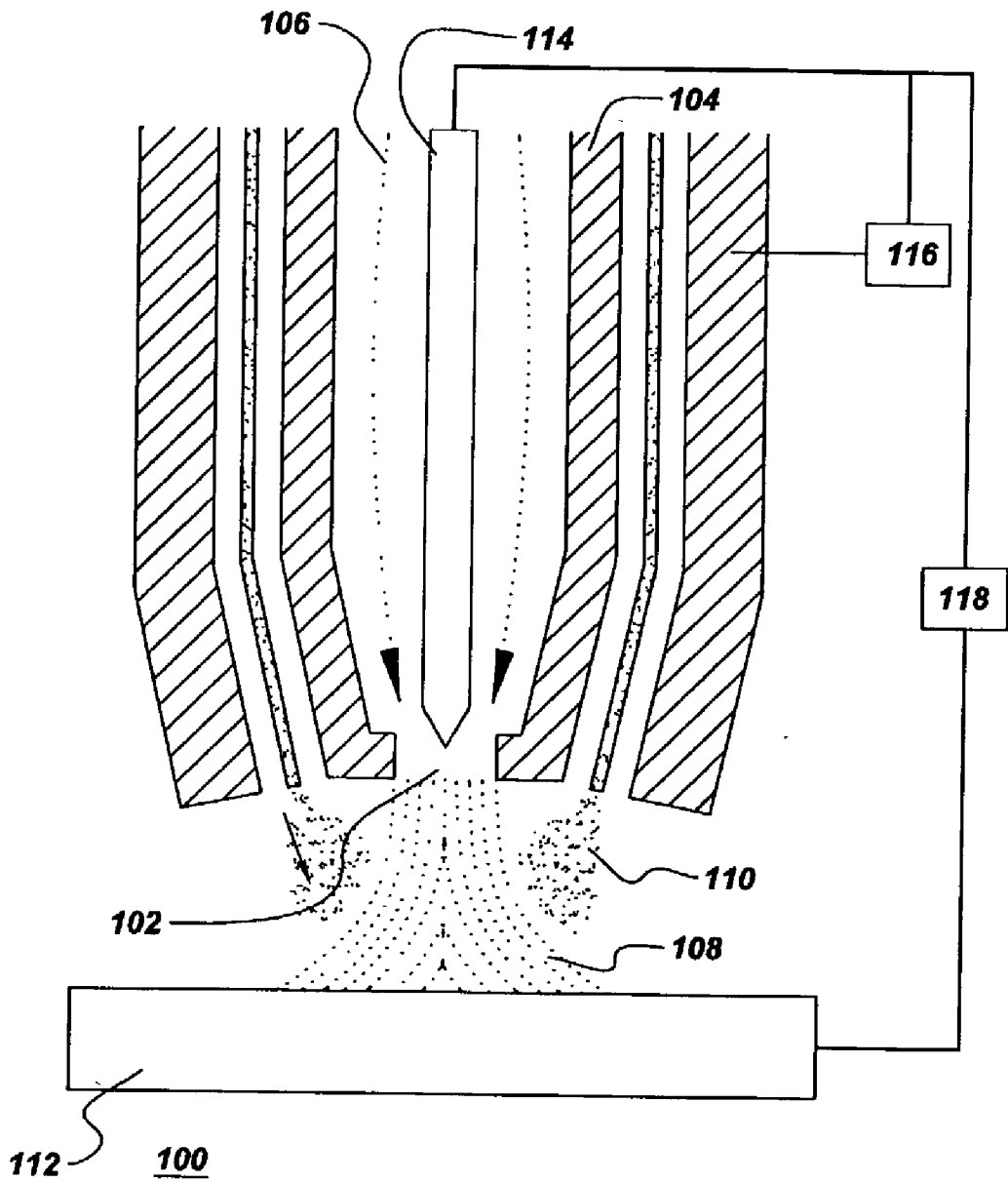

Fig. 1

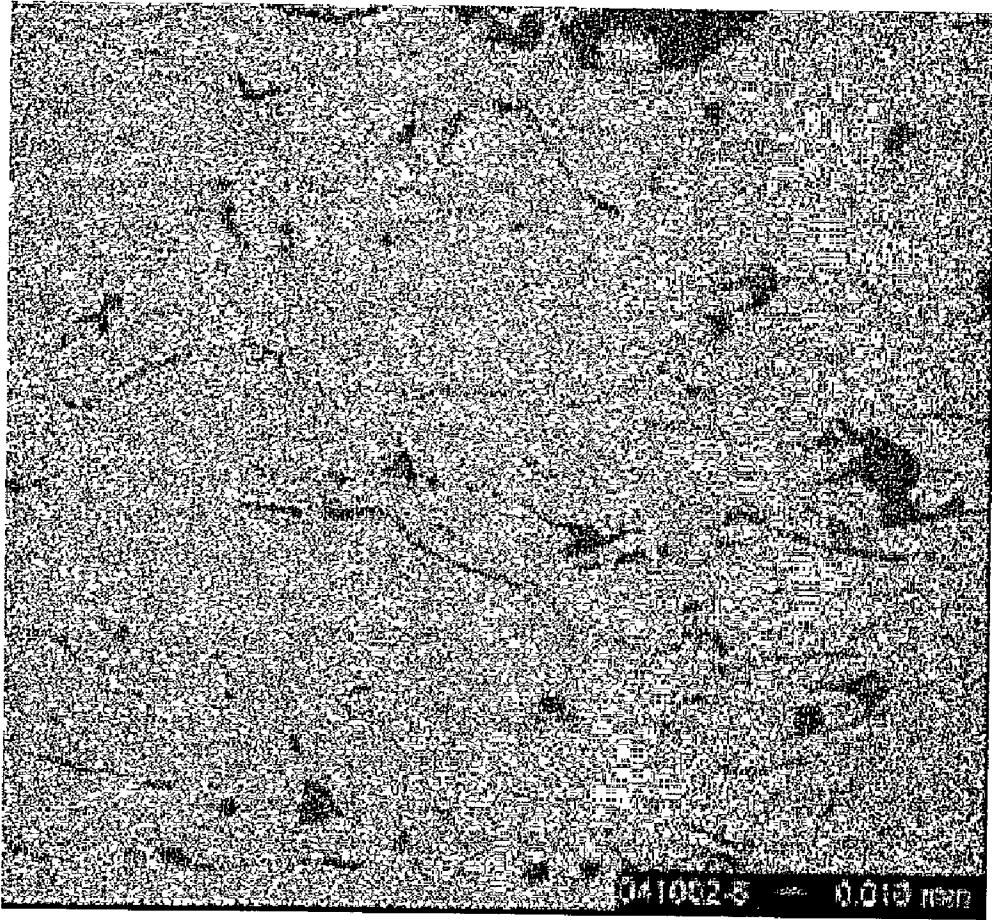

Fig. 2

**METHOD FOR COATING ARTICLES USING A
PLASMA TRANSFERRED TORCH IN
NON-TRANSFERRED MODE, AND RELATED
METHODS FOR REPAIRING AND
MANUFACTURING ARTICLES**

BACKGROUND OF INVENTION

[0001] This invention relates to methods for applying coatings to articles. More particularly, this invention relates to methods for protecting articles from degradation using coatings. This invention also relates to methods for in-situ repair of an article.

[0002] Articles exposed to corrosive, abrasive, or otherwise deleterious environments are often coated with resistant materials designed to isolate the underlying material from exposure to the environment, thereby protecting the article from degradation. Many different protective systems have been developed for use in various industries and applications. Many of these coatings have been developed for use in thermal spray processes, where solid raw materials in powder, wire, or other form are injected into a flame or plasma torch, at least partially melted, and sprayed onto a substrate. For example, plasma-sprayed thermal barrier coating (TBC) systems have been developed for use in gas turbine assemblies and other high-temperature applications, to protect coated components from the effects of heat and oxidation. TBC systems typically comprise a metallic, oxidation-resistant layer, referred to as a "bond coat," and a thermally resistant ceramic topcoat, often comprising stabilized zirconia. Other non-limiting examples of protective coatings include tungsten carbide-cobalt coatings for wear resistance, and nickel-based coatings for corrosion resistance.

[0003] Thermal-spray coatings have been used effectively to extend the useful service lives and capabilities of articles for a considerable number of years. However, despite the effectiveness of coating technology to this end, coated articles eventually require maintenance and repair. Repair operations often include stripping of at least some of the coating from the article, and, in some cases, a further operation, such as welding, is performed on the article in the stripped area to refurbish the underlying article. In order to enhance the performance of the repaired article, selectively applying a new coating over the stripped and refurbished area is desirable. However, current techniques for applying coatings to selective areas are often time-consuming and expensive, requiring complicated masking procedures to ensure that the new coating is sprayed in the precise area of the repair. Furthermore, in complex assemblies of coated components, such as, for example, gas turbine assemblies, current techniques require removal of components from the assembly prior to the repair operation, due in part to the need to provide access to the component for welding and coating equipment. The need for removal of components increases the cost of the operation in terms of labor time and in lost revenue due to component "down-time."

[0004] Therefore, there is a need to provide alternative methods for depositing coatings on articles. There is a further need for methods for repairing coated articles to reduce the cost and time needed to accomplish repairs.

SUMMARY OF INVENTION

[0005] Embodiments of the present invention address these and other needs. One embodiment is a method for

protecting an article from degradation, the method comprising providing a substrate; providing a Plasma Transferred Arc (PTA) apparatus; setting the PTA apparatus to operate in a non-transferred arc mode; and disposing at least one coating on the substrate using the PTA apparatus in the non-transferred arc mode.

[0006] A second embodiment is a method for in-situ repair of a component of an assembly, the method comprising: providing a substrate, the substrate comprising a component of an assembly and coupled to the assembly; providing a PTA apparatus; welding the substrate using the PTA apparatus in a transferred arc mode to form a welded region on the substrate; setting the PTA apparatus to operate in a non-transferred arc mode; and disposing at least one coating on the welded region of the substrate using the PTA apparatus in the non-transferred arc mode, wherein the PTA apparatus is operated using a pilot arc power supply to dispose the at least one coating.

BRIEF DESCRIPTION OF DRAWINGS

[0007] These and other features, aspects, and advantages of the present invention will become better understood when the following detailed description is read with reference to the accompanying drawings in which like characters represent like parts throughout the drawings, wherein:

[0008] **FIG. 1** is a schematic representation of an exemplary PTA apparatus; and

[0009] **FIG. 2** is a photomicrograph of a coating deposited by the method of the present invention.

DETAILED DESCRIPTION

[0010] The method of the present invention comprises providing a substrate. In certain embodiments, providing the substrate comprises providing a substrate comprising at least one of a metal, a ceramic, and a plastic. In particular embodiments, providing the substrate comprises providing a substrate comprising an alloy. The alloy comprises any of several metals common to industry, including at least one of nickel, cobalt, iron, aluminum, and stainless steel.

[0011] In some embodiments, providing the substrate comprises providing a component of a gas turbine assembly. Providing the component, in certain embodiments, comprises removing the component from a turbine assembly. Such an embodiment applies, as a non-limiting example, to certain repair operations in which the component is removed from the assembly to allow access to the damaged region. The component alternatively may be provided as a newly manufactured component, or as a component coupled to a gas turbine assembly. The latter alternative, in which the component is provided coupled to an assembly, is referred to herein as an "in-situ repair" method, about which more will be described herein.

[0012] In the method of the present invention, a Plasma Transferred Arc (PTA) apparatus **100** is provided. A large number of commercial PTA units are available, and the schematic shown in **FIG. 1** is presented merely to illustrate the basic components of a typical PTA apparatus **100**. An electric arc is constricted by passing the arc through an orifice **102** in a nozzle **104**. Gas **106** passing through orifice **102** is heated to the point of ionization by the electric arc, generating a plasma **108**. Injected material **110**, often

injected into plasma **108** in powder form as shown in **FIG. 1**, may be used to deposit a coating on a substrate **112**, or as conventional filler material when the PTA apparatus **100** is used to weld substrate **112**. There are two modes of operating a PTA apparatus. The non-transferred arc mode is in use when electrical current flow occurs from an electrode **114** to nozzle **104** to a first power supply **116**. The transferred arc mode is in use when current flow is from electrode **114** through orifice **102** to substrate **112** to a second power supply **118**. The non-transferred arc as used in a PTA apparatus is referred to as a "pilot arc" and is conventionally used to strike the transferred arc between nozzle **104** and substrate **112**. Additionally, the pilot arc occasionally may be used to stabilize the transferred arc during the PTA coating operation, particularly where low transferred arc power is desirable to maintain low substrate **12** temperatures. First power supply **116** is referred to as a "pilot arc power supply" and is generally designed to supply a significantly lower current than second power supply ("transferred arc power supply") **118**.

[**0013**] In conventional methods of using commercial PTA apparatus **100**, substantially all of the energy used to melt injected material **110** for the purpose of coating substrate **112** is provided by transferred arc power supply **118**. However, in stark contrast to conventional methods, the present inventors have discovered that high-quality coatings can be applied with highly desirable control of coating placement using a conventional PTA apparatus **100** in non-transferred mode, including, for example, heating injected material **110** to deposit a coating on substrate **112** using energy provided substantially exclusively by the pilot arc power supply **116**. Accordingly, the method of the present invention further comprises setting the PTA apparatus to operate in a non-transferred arc mode; and disposing at least one coating on the substrate **112** using the PTA apparatus **100** in the non-transferred arc mode, and in particular embodiments, disposing the at least one coating comprises operating the PTA apparatus **100** using a pilot arc power supply **116** to dispose the at least one coating.

[**0014**] The precise control of coating placement, combined with the compact configuration of the PTA apparatus **100** relative to conventional plasma spray equipment, advantageously provides the method of the present invention with the ability to selectively apply coatings in narrow areas, such as weld beads, for example, and areas that are inaccessible to conventional coating equipment. This ability enables the method of the present invention to be used, for example, in certain "in-situ repair" embodiments as described above, wherein disposing the at least one coating comprises disposing the at least one coating on the component, wherein the component is coupled to a gas turbine assembly. By enabling in-situ repair methods, the method of the present invention provides the potential for significantly faster and more cost effective repair of components, because the conventional step of disassembling the turbine assembly is not needed.

[**0015**] The PTA apparatus **100** provided for use in the method of the present invention is suitable for use in various welding operations in addition to coating methods described above. This welding capability can be advantageously combined with the aforementioned coating capability to provide a welding and coating operation that operates using the same equipment, thereby avoiding the need to change equipment

when the processing changes from welding to coating. Accordingly, in certain embodiments, the method of the present invention further comprises welding the substrate using the PTA apparatus in a transferred arc mode to form a welded region on the substrate prior to disposing the at least one coating on the substrate using the PTA apparatus in the non-transferred arc mode. In particular embodiments, disposing the at least one coating comprises disposing the coating on the welded region of the substrate. The area of coating deposition applied by the PTA apparatus **100** operating according to the method of the present invention is sufficiently narrow to allow fine control of coating coverage such that coverage of a welded region, such as a weld bead, is advantageously accomplished without extensive use of masking, further reducing the time and cost of the overall repair.

[**0016**] Injected material **110** is also referred to herein as "feedstock material," as it serves as raw material for processing into the deposited coating. In certain embodiments of the present invention, disposing the at least one coating comprises using a feedstock material **110** in a form selected from the group consisting of powder, wire, rod, sheet, paste, and combinations thereof. In some embodiments, disposing the at least one coating comprises disposing at least one of a metal and a ceramic, for example, a bond coat material. Alternatives for a bond coat material suitable for disposition by the method of the present invention include a material comprising MCrAlX-type material, wherein M is at least one of nickel, cobalt, and iron, and wherein X is at least one of yttrium and zirconium; and a material comprising an aluminide compound, such as at least one of nickel aluminide and platinum nickel aluminide.

[**0017**] In some embodiments, disposing the at least one coating comprises disposing a thermal barrier coating, such as, for example, a material comprising yttria-stabilized zirconia. Those skilled in the art will appreciate that other types of specific useful coatings are suitable for deposition by the method of the present invention, including, but not limited to, coatings comprising at least one of wear-resistant coatings, such as tungsten carbide-cobalt material; corrosion-resistant coatings; and solders and brazes.

[**0018**] In order to further capitalize on the advantages of the method of the present invention, further embodiments include a method for protecting an article from degradation, the method comprising providing a substrate **112**; providing a PTA apparatus **100**; welding the substrate **112** using the PTA apparatus **100** in a transferred arc mode to form a welded region on the substrate; setting the PTA apparatus **100** to operate in a non-transferred arc mode; and disposing at least one coating on the welded region of the substrate **112** using the PTA apparatus **100** in the non-transferred arc mode, wherein the PTA apparatus **100** is operated using a pilot arc power supply **116** to dispose the at least one coating.

[**0019**] As described above, the fine coating deposition control and compact geometry of a PTA apparatus **100** provides the ability in some cases to repair components without removing them from an overall assembly. Accordingly, embodiments of the present invention include a method for in-situ repair of a component of an assembly, the method comprising providing a substrate, the substrate comprising a component of an assembly and coupled to the assembly; providing a PTA apparatus; welding the substrate using the PTA apparatus in a transferred arc mode to form a welded region on the substrate; setting the PTA apparatus

to operate in a non-transferred arc mode; and disposing at least one coating on the welded region of the substrate using the PTA apparatus in the non-transferred arc mode, wherein the PTA apparatus is operated using a pilot arc power supply to dispose the at least one coating.

[0020] The following example is set forth to further describe exemplary embodiments of the present invention, and should not be construed as limiting the invention in any way. A Stellite Starweld PTA hardfacing apparatus was set in non-transferred arc mode, and using the pilot arc power supply of the PTA apparatus, an MCrAlY-type coating Praxair Ni 211-2 powder was deposited on a type 304 Stainless Steel substrate using the following processing parameters:

- [0021] Current: 150-200 Amps
- [0022] Voltage: 23-29 Volts
- [0023] Gun travel speed: 300-600 mm/sec
- [0024] Powder feed rate: 1-1.5 Lbs/Hr
- [0025] Powder: Praxair Ni211-2 MCrAlY powder.

[0026] The coating, shown in FIG. 2, was prepared in 8 passes, had a thickness of about 0.38 mm and had a microstructure of suitable density and composition for use as a TBC bond coat.

[0027] While various embodiments are described herein, it will be appreciated from the specification that various combinations of elements, variations, equivalents, or improvements therein may be made by those skilled in the art, and are still within the scope of the invention as defined in the appended claims.

1. A method for protecting an article from degradation, said method comprising:

providing a substrate;

providing a Plasma Transferred Arc (PTA) apparatus;

setting said PTA apparatus to operate in a non-transferred arc mode; and

disposing at least one coating on said substrate using said PTA apparatus in said non-transferred arc mode.

2. The method of claim 1, wherein disposing said at least one coating comprises operating said PTA apparatus using a pilot arc power supply to dispose said at least one coating.

3. The method of claim 1, further comprising welding said substrate using said PTA apparatus in a transferred arc mode to form a welded region on said substrate prior to disposing said at least one coating on said substrate using said PTA apparatus in said non-transferred arc mode.

4. The method of claim 3, wherein disposing said at least one coating comprises disposing said coating on said welded region of said substrate.

5. The method of claim 1, wherein providing said substrate comprises providing a substrate comprising at least one of a metal, a ceramic, and a plastic.

6. The method of claim 5, wherein providing said substrate comprises providing a substrate comprising an alloy, said alloy comprising at least one of nickel, cobalt, iron, aluminum, and stainless steel.

7. The method of claim 1, wherein providing said substrate comprises providing a component of a gas turbine assembly.

8. The method of claim 7, wherein providing said component comprises removing said component from said turbine assembly.

9. The method of claim 7, wherein disposing said at least one coating comprises disposing said at least one coating on said component wherein said component is coupled to said gas turbine assembly.

10. The method of claim 1, wherein disposing said at least one coating comprises using a feedstock material in a form selected from the group consisting of powder, wire, rod, sheet, paste, and combinations thereof.

11. The method of claim 1, wherein disposing said at least one coating comprises disposing at least one of a metal and a ceramic.

12. The method of claim 11, wherein disposing said at least one coating comprises disposing a bond coat material.

13. The method of claim 12, wherein disposing said bondcoat material comprises disposing a material comprising MCrAlX-type material, wherein M is at least one of nickel, cobalt, and iron, and wherein X is at least one of yttrium and zirconium.

14. The method of claim 12, wherein disposing said bondcoat material comprises disposing material comprising an aluminide compound.

15. The method of claim 11, wherein disposing said at least one coating comprises disposing a thermal barrier coating.

16. The method of claim 15, wherein disposing said thermal barrier coating comprises disposing a material comprising yttria-stabilized zirconia.

17. A method for protecting an article from degradation, said method comprising:

providing a substrate;

providing a PTA apparatus;

welding said substrate using said PTA apparatus in a transferred arc mode to form a welded region on said substrate;

setting said PTA apparatus to operate in a non-transferred arc mode; and

disposing at least one coating on said welded region of said substrate using said PTA apparatus in said non-transferred arc mode, wherein said PTA apparatus is operated using a pilot arc power supply to dispose said at least one coating.

18. A method for in-situ repair of a component of an assembly, said method comprising:

providing a substrate, said substrate comprising a component of an assembly and coupled to said assembly;

providing a PTA apparatus;

welding said substrate using said PTA apparatus in a transferred arc mode to form a welded region on said substrate;

setting said PTA apparatus to operate in a non-transferred arc mode; and

disposing at least one coating on said welded region of said substrate using said PTA apparatus in said non-transferred arc mode, wherein said PTA apparatus is operated using a pilot arc power supply to dispose said at least one coating.

* * * * *