



(11) **EP 1 747 890 B1**

(12) **EUROPEAN PATENT SPECIFICATION**

(45) Date of publication and mention of the grant of the patent:
09.09.2015 Bulletin 2015/37

(51) Int Cl.:
B41J 2/175^(2006.01)

(21) Application number: **06116943.9**

(22) Date of filing: **11.07.2006**

(54) **Method of determining the droplet size of ink droplets released by an ink jet printer**

Verfahren zur Bestimmung der Tropfengrösse von Tintentropfen , die durch einen Tintenstrahldrucker ausgestossen werden.

Méthode de détermination de la taille de gouttelettes d'encre éjectées par une imprimante à jet d'encre

(84) Designated Contracting States:
AT BE BG CH CY CZ DE DK EE ES FI FR GB GR HU IE IS IT LI LT LU LV MC NL PL PT RO SE SI SK TR

(30) Priority: **26.07.2005 EP 05106848**

(43) Date of publication of application:
31.01.2007 Bulletin 2007/05

(73) Proprietor: **Océ-Technologies B.V.**
5914 CA Venlo (NL)

(72) Inventor: **Reinten, Hans**
5941 BD, Velden (NL)

(74) Representative: **Janssen, Paulus J. P.**
Océ-Technologies B.V.
Corporate Patents,
P.O. Box 101
5900 MA Venlo (NL)

(56) References cited:
US-A- 5 682 183 US-A1- 2003 146 945
US-A1- 2004 021 711 US-A1- 2004 027 432
US-B1- 6 791 704

EP 1 747 890 B1

Note: Within nine months of the publication of the mention of the grant of the European patent in the European Patent Bulletin, any person may give notice to the European Patent Office of opposition to that patent, in accordance with the Implementing Regulations. Notice of opposition shall not be deemed to have been filed until the opposition fee has been paid. (Art. 99(1) European Patent Convention).

Description

[0001] The invention relates to a method of determining the average droplet size of ink droplets released by an ink jet printer with an ink reservoir and a dispensing device for dosing ink to the reservoir. The invention also relates to an ink jet printer typically adapted for performing the method according to the invention.

[0002] Control of droplet speed and droplet size within an ink jet printer is important for maintaining print quality and reliability of the jetting process itself. Both the droplet speed and the droplet size may drift due to various causes, such as drift in piezo-actuation efficiency, batch variations in ink properties, and temperature drift. For most causes of drift, droplet speed and droplet size are coupled. For this reason, it would be satisfying to solely measure the droplet size. Moreover, the droplet size itself commonly provides other relevant information, such as (among others) information about the print quality. A direct way to measure droplet size is by weighing a large known number of droplets by means of a balance. However, including a balance within an ink jet printer is relatively costly and is commonly undesired from a constructive point of view.

[0003] US 2003/014695 A1 and US 5682183 each disclose determining an ink level of an ink reservoir and determining a number of ejected ink droplets and determining from the ink level and the number of ejected droplets an average droplet size.

[0004] US6334658B1 discloses an inkjet printer configured to detect a jetting failure by comparing a calculated ink consumed quantity and a quantity of ink in a single ink pellet.

[0005] It is an object of the invention to provide an improved method for determining the average droplet size of ink droplets released by an ink jet printer.

[0006] This object can be achieved by providing a method according to the preamble, comprising the steps of: A) measuring an amount of ink dosed to the ink reservoir of the inkjet printer, said ink reservoir having a substantially predetermined volume, B) measuring the ink level within said ink reservoir, C) measuring the number of ink droplets released by at least one nozzle operatively connected to the ink reservoir, and D) determining the average ink droplet size based upon the measured values gathered in steps A)-C). By generating a balance of matter, in particular an ink balance, of the ink jet printer as a system with an inlet for ink (ink dosed to the ink reservoir), an outlet for ink (ink released via the nozzle), and an ink container (formed by the ink reservoir itself), different parameters can be obtained during a period of time, based upon which the average droplet size can be calculated by means of an algorithm. Waste-ink created by purging and cleaning the ink reservoir can be compensated for in the method according to the invention, for example by resetting reference values before actually monitoring the printing process, and in particular the jetting process. The accuracy of the method according to

the invention is dependent on the number of the droplets released by the nozzle(s). Laboratory test results show that an average daily use suffices for useful daily information about drift in droplet size. The drift in ink droplet size can therefore be recorded on a daily base, or — if desired — even more frequently. Based on the information of the average droplet size by counting the drive pulse settings can be adjusted thereby enabling permanent optimisation of the print quality and reliability of the printing process. It is noted that also other kind of information may be used to adjust the drive pulse settings, such as drift in alignment of print heads in a scanning direction (which may be measured by means of test patterns on a receiving substrate like a sheet of paper), and the number of printer failures due to air entrapment. The information concerning (possible) drift of the droplet size may also be used for adjusting settings related to colour management and/or the optical (printing) density (OD). An ink jet printer commonly comprises one or more print heads, each print head comprising multiple ink reservoirs, wherein each ink reservoir is provided with at least one nozzle, and commonly multiple nozzles, for releasing ink droplets. Hence, preferably the method according to the invention is applied to the print head or the assembly of print heads as a whole, wherein the print head is considered as being the system as described afore to which the balance of matter is applied. For a skilled person, it could also be conceivable to consider each ink reservoir and its nozzle(s) as a (micro)system to which the method according to the invention is applied. However, in practice it is expected that this latter option is less preferable.

[0007] In a preferred embodiment the method further comprises step E) of measuring the number of pressure pulses, in particular activation pulses, to selectively expel the ink droplets via the nozzle, wherein the average ink droplet size is based upon measured values gathered in steps A)-C) and E) according to step D). By measuring the number of pressure pulses, in particular activation pulses an indication can be obtained of the amount of ink droplets released by the nozzle(s) thereby extending, and hence improving the balance of matter, in particular the balance of ink, of the ink jet printer. There are two basic propulsion techniques for the drop-on-demand ink jet printers. One uses a piezoelectric transducer to produce pressure pulses selectively to expel the droplets and the other technique uses thermal energy, usually the momentary heating of a resistor, to produce a vapour bubble in the ink, which during its growth expels a droplet. Either technique uses ink-filled channels or passages which interconnect an orifice or nozzle and an ink-filled manifold. The pressure pulse may be generated anywhere in the channels or the manifold. However, the bubble generating resistor (hence the name bubble jet) must be located in each channel near the nozzle.

[0008] During step A) the amount of ink dosed to the ink reservoir is measured by counting the number of ink pellets dosed to the ink reservoir, each pellet having a substantially predetermined and identical volume. In this

manner, the ink supply to the ink reservoir can be controlled and dosed relatively accurately. The ink pellets are preferably formed by hot melt ink, id est an ink which is solid at room temperature but liquid at elevated temperature. For this purpose, the ink is first heated in the inkjet print head to a temperature at which it is liquid, id est has a consistency such that it can be ejected in the form of small drops by means of the print head.

[0009] The ink level within the ink reservoir can be detected by means of different kind of sensors such as a float level indicator, electrical resistance, and a thermal sensor. Though preferably, during step B) the ink level within the ink reservoir is measured by means of at least one thermistor, preferably an NTC thermistor. Application of an NTC thermistor is relatively inexpensive with respect to the application of other types of thermal sensors. However, under specific circumstances it could also be conceivable for a person skilled in the art to apply a PTC type thermistor, or even other kinds of temperature sensitive (electronic) detecting means.

[0010] In a preferred embodiment during step C) the number of ink droplets released by the at least one nozzle of the ink reservoir is measured by counting the number of ink droplets released. To this end, preferably a droplet counter is provided to count the number of ink droplets expelled from the ink reservoir via the nozzles.

[0011] The measured values of steps A)-C) (and step E) if applicable) are preferably transmitted to a control unit to process these data to calculate the average droplet size according to step D) by means of an algorithm stored in the control unit. The control unit may be programmed to (automatically) adjust subsequently certain specific printer settings, such as the drive pulse settings, the settings related to colour management, and/or the settings related to the optical density (OD).

[0012] As aforementioned the ink dosed to the ink reservoirs is preferably formed by hot melt pellets. To melt these ink pellets and to keep these pellets in a molten state within the ink reservoir, the ink within the ink reservoir is preferably heated. In this manner, the ink contained within the ink reservoir can be kept easily at an elevated temperature typically of about 130° Celsius.

[0013] The invention also relates to a computer program adapted for carrying out the method according to the invention. In this manner, the average ink droplet size (step D)) can be determined by means of the computer program acting as a software level sensor for performing step B). The computer program may be embedded within the ink jet printer.

[0014] The invention further relates to a computer running the computer program according to the invention. This computer may form part of the ink jet printer according to the invention. The aforementioned control unit may be an integral part of the computer.

[0015] Moreover, the invention relates to an ink jet printer comprising: a print head comprising a plurality of nozzles, and ink channels arranged side by side, each nozzle being connected to an ink reservoir via its asso-

ciated ink channel; and a device for dispensing ink pellets of substantially predetermined and identical volume to the ink reservoir, wherein the ink jet printer further comprises first counting means for counting the number of ink pellets dispensed to the reservoir, second counting means for counting the number of ink droplets released by the nozzles, detecting means for detecting the ink level within each ink reservoir, and controlling means for determining the average droplet size of ink droplets released by the nozzles based upon measured values gathered by the first counting means, the second counting means, and the detecting means. Preferably though not exclusively, the or each ink reservoir is provided with multiple nozzles. By means of different sensors and counters a volume balance of ink can be made up, as a result of which the average droplet size of ink droplets released by the nozzles can be determined relatively simply, though relatively truthfully and accurately. Advantages of determining the average droplet size in this manner are already elucidated above in a comprehensive manner. In a preferred embodiment the second counting means are adapted for counting the number of pressure pulses produced to expel the ink droplets via the nozzles. In this manner, the jetting process, and hence a (possible) drift in droplet size of ink droplets released via the nozzles can be mapped commonly (even) more realistically.

[0016] The invention can further be illustrated by way of the following non-limitative embodiment, wherein:

figure 1 shows a perspective view of an ink jet printer according to the invention.

[0017] Figure 1 shows a perspective view of an ink jet printer 1 according to the invention. In this embodiment the printer 1 comprises a roller 2 to support a substrate 3 and move it along the four print heads 4. The roller 2 is rotatable about its axis as indicated by arrow A. A carriage 5 carries the four print heads 4 and can be moved in reciprocation in the direction indicated by the double arrow B, parallel to roller 2. In this way the print heads 4 can scan the receiving substrate 3, for example a sheet of paper. The carriage 5 is guided over rods 6 and 7 and is driven by means suitable for the purpose (not shown). In the embodiment shown in this figure, each print head 4 contains eight ink reservoirs (not shown) connected to eight ink ducts, each with its own nozzle 8, which form two rows of four nozzles 8 each perpendicular to the axis of the roller 2. In a practical embodiment of the printer 1, the number of ink ducts per print head 4, and a number of nozzles 8 per ink reservoir will commonly be many times greater. Each ink duct is provided with means for energising the ink duct (not shown) and an associated electric actuation circuit (not shown). In this way, the ink duct, the said means for energising the ink duct, and the actuation circuit form a unit which can serve to eject ink drops in the direction of roller 2. If the ink ducts are energised image-wise, an image forms which is built up

from ink drops on the substrate 3. When a substrate is printed with a printer 1 of this kind in which ink drops are ejected from ink ducts, the substrate, or part thereof, is (imaginarily) divided into fixed locations which form a regular field of pixel rows and pixel columns. In one embodiment, the pixel rows are perpendicular to the pixel columns. The resulting separate locations can each be provided with one or more ink drops. The number of locations per unit of length in the directions parallel to the pixel rows and pixel columns is termed the resolution of the printed image, and is indicated, for example, as 400 x 600 d.p.i. ("dots per inch"). By image-wise energization of a row of nozzles of the print head of the printer when it moves over a strip of the substrate 3 in a direction substantially parallel to the pixel rows, the row of nozzles being substantially parallel to the pixel columns, as shown in this figure, an image built up from ink drops forms on the substrate 3. In this embodiment, the printer 1 is provided with a number of dispensing devices 9, one for each colour, only one being shown in this figure for simplification. With a dispensing device of this kind it is possible to dispense ink pellets at each of the print heads 4. The ink used is a hot melt ink. An ink of this kind is solid at room temperature and liquid at elevated temperature. This ink is dispensed in solid form in each of the print heads whereafter the ink in the print head is melted and is brought to operating temperature, typically 130° Celsius. As soon as there is a shortage of liquid ink in one of the print heads, the carriage 5 will be so moved that the relevant print head is disposed beneath the corresponding dispensing device level with dispensing line 10. One or more ink pellets will then be dispensed to the print head, said pellets entering the print head via opening 11. These pellets are then melted and brought to operating temperature. In this way each print head can be provided with sufficient ink at all times. To be able to optimise the printing process, and in particular the print quality determined by multiple factors, such as the optical density (OD), the colour management and drive pulse settings, it is important to know and hence to determine the average droplet size of the ink droplets released via the nozzles 8. To this end, the printer 1 according to this embodiment, and in particular each reservoir further comprises a counter 12 for counting the number of ink droplets released by the nozzles 8, a counter 13 for counting the number of drive pulses produced, and an ink level sensor 14 (schematically shown). The dispensing device 9 comprises a counter 15 for counting the number of ink pellets dispensed. All counters 12, 13, 15 and the ink level sensor 14 are coupled to a control unit 16. Based upon the measured values gathered by the counters 12, 13, 15 and the ink level sensor 14 the average droplet size can be calculated by the control unit 16. The control unit 16 is also adapted to control both the dispensing devices 9 and the printer carriage 5 to timely supply the ink reservoirs with sufficient (and preferably not an overdose) ink dependent on the printing tasks to be performed within a certain timeframe and to be able to optimise the

print quality of the printer 1 permanently dependent on the actual (average) droplet size calculated by the control unit 16.

Claims

1. Method of determining the average droplet size of ink droplets released by an ink jet printer (1), the inkjet printer comprising

- a control unit (16),
- an ink reservoir, the ink reservoir having a substantially predetermined volume
- a print head (4) comprising a plurality of nozzles and ink channels arranged side by side, each nozzle being connected to the ink reservoir via its associated ink channel
- a dispensing device (9) for dispensing ink pellets of substantially predetermined and identical volume to the ink reservoir;
- a carriage (5) carrying the print head, the carriage being moveable for disposing the print head beneath the dispensing device,
- first counting means (15) for counting a number of ink pellets dispensed to the reservoir,
- second counting means (12) for counting the number of ink droplets released by the nozzles,
- detecting means (14) for detecting the ink level within each ink reservoir;

the method comprising the steps of:

- A) measuring an amount of ink dosed to the ink reservoir by the first counting means by counting the number of ink pellets dispensed to the ink reservoir of the print head of the inkjet printer;
- B) measuring the ink level within said ink reservoir by the detecting means (14),
- C) measuring the number of ink droplets released by at least one nozzle (8) operatively connected to the ink reservoir by the second counting means by counting the number of ink droplets released by the nozzles, and
- D) determining the average ink droplet size by the control unit based upon the measured values gathered in steps A) - C); and
- F) controlling the dispensing device and the carriage by the control unit to timely supply the ink reservoir with sufficient ink dependent on the printing tasks to be performed within a certain timeframe and to optimize the print quality of the inkjet printer permanently on the actual average droplet size determined by the control unit.

2. Ink jet printer (1) comprising:

- a print head (4) comprising: a plurality of noz-

zles (8), and ink channels arranged side by side, each nozzle being connected to an ink reservoir via its associated ink channel, and

- a dispensing device (9) for dispensing ink pellets of substantially predetermined and identical volume to the ink reservoir,
- a carriage (5) carrying the print head, the carriage being moveable for disposing the print head beneath the dispensing device,

wherein the ink jet printer further comprises first counting means (15) for counting the number of ink pellets dispensed to the reservoir, second counting means (12) for counting the number of ink droplets released by the nozzles, detecting means (14) for detecting the ink level within each ink reservoir, and a control unit (16) for determining the average droplet size of ink droplets released by the nozzles based upon measured values gathered by the first counting means, the second counting means, and the detecting means; and

wherein the control unit is adapted for controlling the dispensing device and the carriage to timely supply the ink reservoir with sufficient ink dependent on the printing tasks to be performed within a certain time-frame and to optimize the print quality of the inkjet printer permanently on the actual average droplet size determined by the control unit.

Patentansprüche

1. Verfahren zum Bestimmen der mittleren Tropfengröße von Tintentropfen, die von einem Tintenstrahldrucker (1) ausgestoßen werden, wobei der Tintenstrahldrucker aufweist:

- eine Steuereinheit (16),
- ein Tintenreservoir, das ein im wesentlichen vorbestimmtes Volumen hat,
- einen Druckkopf (4) mit einer Vielzahl von Düsen und Tintenkanälen, die Seite an Seite angeordnet sind, wobei jede Düse über ihren zugehörigen Tintenkanal mit dem Tintenreservoir verbunden ist,
- eine Abgabereinrichtung (9) zur Abgabe von Tintenpellets mit einem im wesentlichen vorbestimmten und identischen Volumen in das Tintenreservoir;
- einen Wagen (5), der den Druckkopf trägt, wobei der Wagen beweglich ist, um den Druckkopf unter die Abgabereinrichtung zu bewegen,
- eine erste Zählleinrichtung (15) zum Zählen einer Anzahl von Tintenpellets, die in das Reservoir abgegeben werden,
- eine zweite Zählleinrichtung (12) zum Zählen der Anzahl von Tintentropfen, die von den Düsen ausgestoßen werden,

- eine Detektoreinrichtung (14) zum Detektieren des Tintenpegels innerhalb jedes Tintenreservoirs;

welches Verfahren die folgenden Schritte aufweist:

- A) Messen einer Menge an Tinte, die in das Tintenreservoir eindosiert wurde, mit Hilfe der ersten Zählleinrichtung durch Zählen der Anzahl von Tintenpellets, die in das Tintenreservoir des Druckkopfes des Tintenstrahldruckers abgegeben wurden;
- B) Messen des Tintenpegels in dem Tintenreservoir mit der Detektoreinrichtung (14),
- C) Messen der Anzahl von Tintentropfen, die von wenigstens einer Düse (8) abgegeben werden, die funktionsmäßig mit dem Tintenreservoir verbunden ist, mit Hilfe der zweiten Zählleinrichtung durch Zählen der Anzahl von Tintentropfen, die von den Düsen abgegeben werden, und
- D) Bestimmen der mittleren Tintentropfengröße mit der Steuereinheit auf der Grundlage der gemessenen Werte, die in den Schritten A) - C) erhalten wurden; und
- F) Steuern der Abgabereinrichtung und des Wagens durch die Steuereinheit, um das Tintenreservoir zeitgerecht mit genügend Tinte zu versorgen, in Abhängigkeit von den innerhalb eines bestimmten Zeitrahmens auszuführenden Druckaufgaben, und um die Druckqualität des Tintenstrahldruckers permanent auf die von der Steuereinheit bestimmte aktuelle tatsächliche Tropfengröße zu optimieren.

2. Tintenstrahldrucker (1) mit:

- einem Druckkopf (4), der aufweist: mehrere Düsen (8) und Tintenkanäle, die Seite an Seite angeordnet sind, wobei jede Düse über ihren zugehörigen Tintenkanal mit einem Tintenreservoir verbunden ist, und
- einer Abgabereinrichtung (9) zur Abgabe von Tintenpellets mit einem im wesentlichen vorbestimmten und identischen Volumen in das Tintenreservoir,
- einem Wagen (5), der den Druckkopf trägt, wobei der Wagen beweglich ist, um den Druckkopf unter die Abgabereinrichtung zu bringen,

wobei der Tintenstrahldrucker weiterhin eine erste Zählleinrichtung (15) zum Zählen der Anzahl von Tintenpellets, die in das Reservoir abgegeben werden, eine zweite Zählleinrichtung (12) zum Zählen der Anzahl von Tintentropfen, die von den Düsen abgegeben werden, eine Detektoreinrichtung (14) zum Detektieren des Tintenpegels innerhalb jedes Tintenreservoirs, und eine Steuereinheit (16) aufweist,

zum Bestimmen der mittleren Tropfengröße der von den Düsen abgegebenen Tintentropfen auf der Grundlage der gemessenen Werte, die von der ersten Zählrichtung, der zweiten Zählrichtung und der Detektoreinrichtung erhalten werden; und wobei die Steuereinheit dazu eingerichtet ist, die Abgabereinrichtung und den Wagen zu steuern, um das Tintenreservoir zeitgerecht mit ausreichend Tinte zu versorgen, abhängig von den innerhalb eines bestimmten Zeitrahmens auszuführenden Druckaufgaben, und um die Druckqualität des Tintenstrahldruckers permanent auf die von der Steuereinheit bestimmte aktuelle mittlere Tropfengröße zu optimieren.

Revendications

1. Procédé de détermination de la taille moyenne de gouttelettes d'encre libérées par une imprimante à jet d'encre (1), l'imprimante à jet d'encre comprenant

- une unité de commande (16),
- un réservoir d'encre, le réservoir d'encre présentant un volume sensiblement prédéterminé
- une tête d'impression (4) comprenant une pluralité de buses et canaux d'encre agencés côte à côte, chaque buse étant reliée au réservoir d'encre via son canal d'encre associé
- un dispositif de distribution (9) pour la distribution de particules d'encre de volume identique et sensiblement prédéterminé au réservoir d'encre ;
- un chariot (5) portant la tête d'impression, le chariot étant mobile pour l'agencement de la tête d'impression sous le dispositif de distribution,
- des premiers moyens de comptage (15) pour le comptage d'un nombre de particules d'encre distribuées au réservoir,
- des seconds moyens de comptage (12) pour le comptage du nombre de gouttelettes d'encre libérées par les buses,
- des moyens de détection (14) pour la détection du niveau d'encre dans chaque réservoir d'encre,

le procédé comprenant les étapes suivantes :

- A) la mesure d'une quantité d'encre dosée ajoutée au réservoir d'encre par les premiers moyens de comptage par le comptage du nombre de particules d'encre distribuées au réservoir d'encre de la tête d'impression de l'imprimante à jet d'encre ;
- B) la mesure du niveau d'encre dans ledit réservoir d'encre par les moyens de détection (14),
- C) la mesure du nombre de gouttelettes d'encre libérées par au moins une buse (8) reliée en

fonctionnement au réservoir d'encre par les seconds moyens de comptage par le comptage du nombre de gouttelettes d'encre libérées par les buses, et

D) la détermination de la taille moyenne de gouttelettes d'encre par l'unité de commande sur la base des valeurs mesurées collectées dans les étapes A) - C) ; et

F) la commande du dispositif de distribution et du chariot par l'unité de commande pour alimenter en temps opportun le réservoir d'encre avec suffisamment d'encre selon les tâches d'impression à réaliser dans une certaine période et pour optimiser la qualité d'impression de l'imprimante à jet d'encre en permanence sur la taille moyenne réelle de gouttelettes déterminée par l'unité de commande.

2. Imprimante à jet d'encre (1) comprenant :

- une tête d'impression (4) comprenant : une pluralité de buses (8) et des canaux d'encre agencés côte à côte, chaque buse étant reliée à un réservoir d'encre via son canal d'encre associé, et
- un dispositif de distribution (9) pour la distribution de particules d'encre de volume identique et sensiblement prédéterminé au réservoir d'encre,
- un chariot (5) portant la tête d'impression, le chariot étant mobile pour l'agencement de la tête d'impression sous le dispositif de distribution,

dans lequel l'imprimante à jet d'encre comprend en outre des premiers moyens de comptage (15) pour le comptage du nombre de particules d'encre distribuées au réservoir, les seconds moyens de comptage (12) pour le comptage du nombre de gouttelettes d'encre libérées par les buses, des moyens de détection (14) pour la détection du niveau d'encre dans chaque réservoir d'encre, et une unité de commande (16) pour la détermination de la taille moyenne de gouttelettes d'encre libérées par les buses sur la base de valeurs mesurées collectées par les premiers moyens de comptage, les seconds moyens de comptage et les moyens de détection ; et dans lequel l'unité de commande est adaptée pour commander le dispositif de distribution et le chariot pour alimenter en temps opportun le réservoir d'encre avec suffisamment d'encre selon les tâches d'impression à réaliser dans une certaine période et pour optimiser la qualité d'impression de l'imprimante à jet d'encre en permanence sur la taille moyenne réelle de gouttelettes déterminée par l'unité de commande.

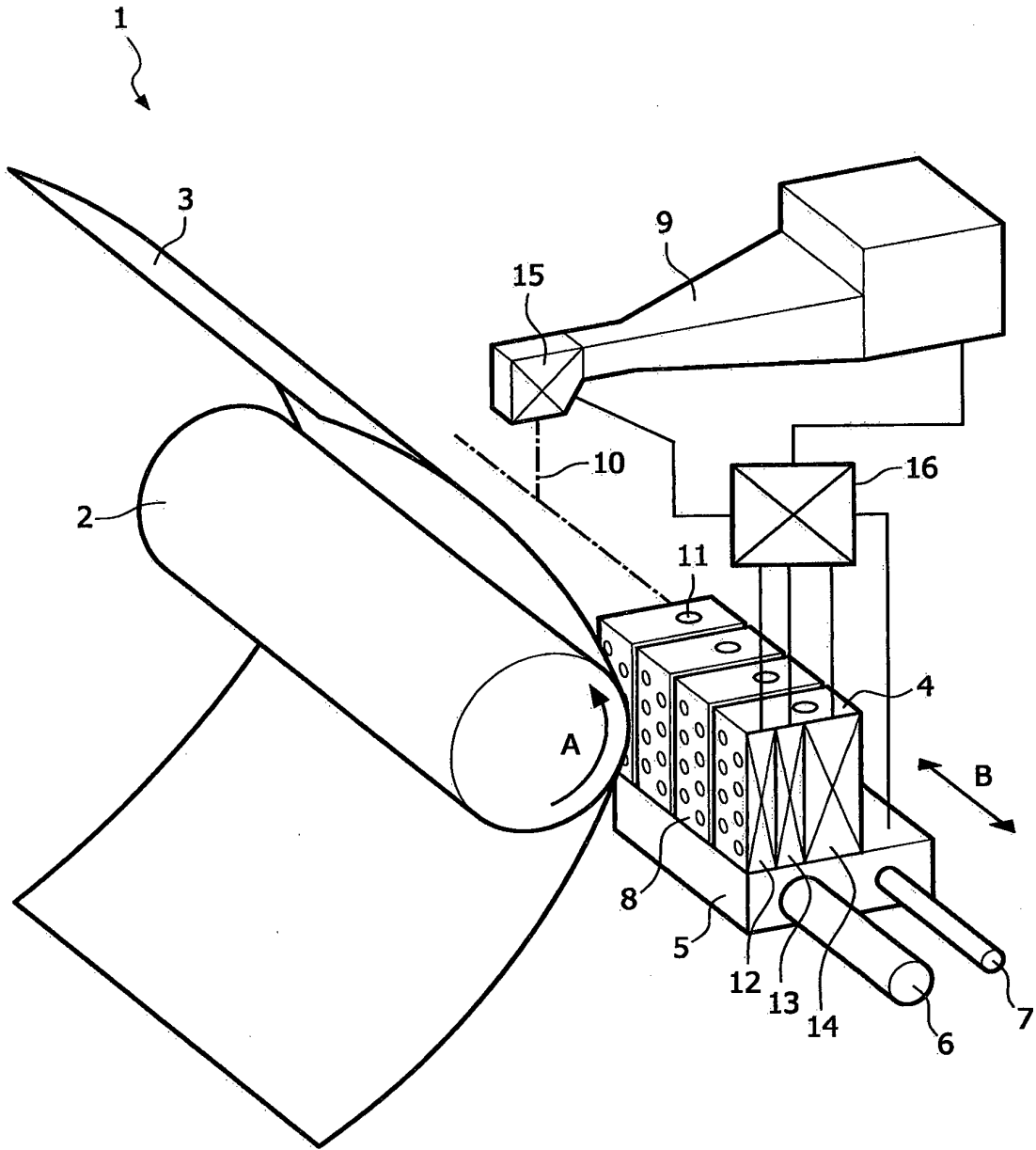

FIG. 1

REFERENCES CITED IN THE DESCRIPTION

This list of references cited by the applicant is for the reader's convenience only. It does not form part of the European patent document. Even though great care has been taken in compiling the references, errors or omissions cannot be excluded and the EPO disclaims all liability in this regard.

Patent documents cited in the description

- US 2003014695 A1 [0003]
- US 5682183 A [0003]
- US 6334658 B1 [0004]