

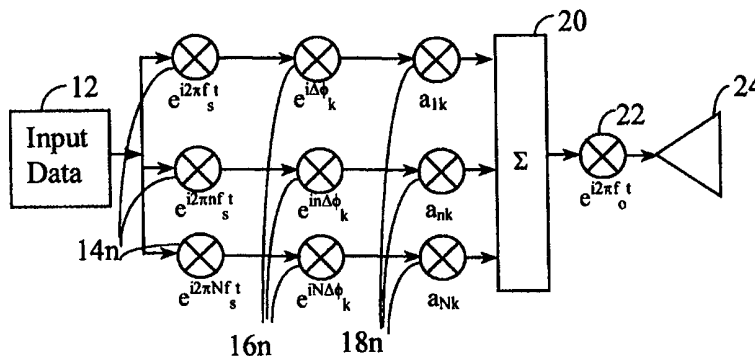

INTERNATIONAL APPLICATION PUBLISHED UNDER THE PATENT COOPERATION TREATY (PCT)

<p>(51) International Patent Classification ⁶ : H04L 1/04</p>	<p>A1</p>	<p>(11) International Publication Number: WO 99/41871 (43) International Publication Date: 19 August 1999 (19.08.99)</p>
<p>(21) International Application Number: PCT/US99/02838 (22) International Filing Date: 10 February 1999 (10.02.99) (30) Priority Data: 09/022,950 12 February 1998 (12.02.98) US (71)(72) Applicant and Inventor: SHATTIL, Steven, J. [US/US]; 4980 Meredith Way #201, Boulder, CO 80303 (US).</p>		<p>(81) Designated States: AU, BR, CA, CN, CZ, HU, ID, IL, IN, IS, JP, KR, MX, NZ, PL, SG, TR, UA, US, Eurasian patent (AM, AZ, BY, KG, KZ, MD, RU, TJ, TM), European patent (AT, BE, CH, CY, DE, DK, ES, FI, FR, GB, GR, IE, IT, LU, MC, NL, PT, SE). Published <i>With international search report. Before the expiration of the time limit for amending the claims and to be republished in the event of the receipt of amendments.</i></p>

(54) Title: MULTIPLE ACCESS METHOD AND SYSTEM



(57) Abstract

A wireless communication system transmits data on multiple carriers simultaneously to provide frequency diversity. Carrier interference causes a narrow pulse in the time domain when the relative phases of the multiple carriers are zero. Selection of the frequency separation and phases of the carriers controls the timing of the pulses. Both time division of the pulses and frequency division of the carriers achieves multiple access. Carrier interferometry is a basis from which other communication protocols can be derived. Frequency hopping and frequency shifting of the carriers does not change the pulse envelope if the relative frequency separation and phases between the carriers are preserved. Direct sequence CDMA signals are generated in the time domain by a predetermined selection of carrier amplitudes. Each pulse can be sampled in different phase spaces at different times. This enables communication in phase spaces that are not detectable by conventional receivers. The time-dependent phase relationship of the carriers provides automatic scanning of a beam pattern transmitted by an antenna array. In waveguide communications, the carrier frequencies and phase space may be matched to the chromatic dispersion of an optical fiber to increase the capacity of the fiber.

FOR THE PURPOSES OF INFORMATION ONLY

Codes used to identify States party to the PCT on the front pages of pamphlets publishing international applications under the PCT.

AL	Albania	ES	Spain	LS	Lesotho	SI	Slovenia
AM	Armenia	FI	Finland	LT	Lithuania	SK	Slovakia
AT	Austria	FR	France	LU	Luxembourg	SN	Senegal
AU	Australia	GA	Gabon	LV	Latvia	SZ	Swaziland
AZ	Azerbaijan	GB	United Kingdom	MC	Monaco	TD	Chad
BA	Bosnia and Herzegovina	GE	Georgia	MD	Republic of Moldova	TG	Togo
BB	Barbados	GH	Ghana	MG	Madagascar	TJ	Tajikistan
BE	Belgium	GN	Guinea	MK	The former Yugoslav Republic of Macedonia	TM	Turkmenistan
BF	Burkina Faso	GR	Greece	ML	Mali	TR	Turkey
BG	Bulgaria	HU	Hungary	MN	Mongolia	TT	Trinidad and Tobago
BJ	Benin	IE	Ireland	MR	Mauritania	UA	Ukraine
BR	Brazil	IL	Israel	MW	Malawi	UG	Uganda
BY	Belarus	IS	Iceland	MX	Mexico	US	United States of America
CA	Canada	IT	Italy	NE	Niger	UZ	Uzbekistan
CF	Central African Republic	JP	Japan	NL	Netherlands	VN	Viet Nam
CG	Congo	KE	Kenya	NO	Norway	YU	Yugoslavia
CH	Switzerland	KG	Kyrgyzstan	NZ	New Zealand	ZW	Zimbabwe
CI	Côte d'Ivoire	KP	Democratic People's Republic of Korea	PL	Poland		
CM	Cameroon	KR	Republic of Korea	PT	Portugal		
CN	China	KZ	Kazakstan	RO	Romania		
CU	Cuba	LC	Saint Lucia	RU	Russian Federation		
CZ	Czech Republic	LI	Liechtenstein	SD	Sudan		
DE	Germany	LK	Sri Lanka	SE	Sweden		
DK	Denmark	LR	Liberia	SG	Singapore		
EE	Estonia						

MULTIPLE ACCESS METHOD AND SYSTEM

Field of the Invention

The present invention relates to a novel multicarrier spread-spectrum protocol for wireless and
5 waveguide communications and radar.

Background of the Invention

Multipath fading is the fluctuation in a received signal's amplitude. It is caused by interference
between two or more versions of the transmitted signal that arrive at a receiver at different times. This
10 interference results from reflections from the ground and nearby structures. The amount of multipath
fading depends on the intensity and propagation time of the reflected signals and the bandwidth of the
transmitted signal. The received signal may consist of a large number of waves having different
amplitudes, and phases, and angles of arrival. These components combine vectorally at the receiver and
cause the received signal to fade or distort.

15 The fading and distortion change as the receiver and other objects in the radio environment move.
These multipath effects depend on the bandwidth of the signal being transmitted. If the transmitted signal
has a narrow bandwidth (i.e., the duration of the data bits transmitted is longer than the delay resulting
from multipath reflections), then the received signal exhibits deep fades as the receiver moves in a
multipath environment. This is known as flat fading. A significant amount of power control (e.g.
20 increasing the transmit power and/or the receiver gain) is needed to compensate for deep fades. In
addition, low data-rate signals experience distortion if the characteristics of the radio environment change
significantly during the duration of a received data bit. The distortion is caused when movement of the
receiver or nearby objects results in a Doppler frequency shift of the received signal that is comparable to
or greater than the bandwidth of the transmit signal.

25 A wideband signal transmitted in a multipath environment results in a frequency-selective fade.
The overall intensity of the received signal has relatively little variation as the receiver moves in a
multipath environment. However, the received signal has deep fades at certain frequencies. If the duration
of the data bits is smaller than the multipath delay, the received signals experience intersymbol
interference resulting from delayed replicas of earlier bits arriving at the receiver.

30 Frequency Division Multiple Access (FDMA) typically suffers from flat fading whereas
multicarrier protocols, such as Orthogonal Frequency Division Multiplexing (OFDM), suffer from
frequency-selective fading. CDMA typically suffers from both; however the direct sequence coding limits
the effects of multipath to delays less than the chip rate of the code. Also, CDMA's capacity is limited by
multi-user interference. Improved CDMA systems use interference cancellation to increase capacity;
35 however, the required signal processing effort is proportional to at least the cube of the bandwidth.
Furthermore, CDMA is susceptible to near-far interference, and its long pseudo-noise (PN) codes require
long acquisition times. For these reasons, OFDM has been merged with CDMA.

OFDM has a high spectral efficiency (the spectrum of the subcarriers overlap) and combats frequency-selective fading. However, the amplitude of each carrier is affected by the Rayleigh law, hence flat fading occurs. Therefore, good channel estimation with an appropriate detection algorithm and channel coding is essential to compensate for fading. The performance of OFDM frequency diversity is comparable to the performance of an optimal CDMA system's multipath diversity (which requires a Rake receiver). Because diversity is inherent in OFDM, it is much simpler to achieve than in an optimal CDMA system. An OFDM system benefits from a lower-speed parallel type of signal processing. A Rake receiver in an optimal CDMA system uses a fast serial type of signal processing, which results in greater power consumption. In addition, the OFDM technique simplifies the channel estimation problem, thus simplifying the receiver design.

In multicarrier CDMA, a spreading sequence is converted from serial to parallel. Each chip in the sequence modulates a different carrier frequency. Thus, the resulting signal has a PN-coded structure in the frequency domain, and the processing gain is equal to the number of carriers. In multi-tone CDMA, the available spectrum is divided into a number of equiwidth frequency bands that are used to transmit a narrowband direct-sequence waveform.

Frequency-hopping spread spectrum can handle near-far interference well. The greatest benefit is that it can avoid portions of the spectrum. This allows the system to better avoid interference and frequency-selective fades. Disadvantages include the requirement for complex frequency synthesizers and error correction.

Time hopping has much higher bandwidth efficiency compared to direct sequence and frequency hopping. Its implementation is relatively simple. However, it has a long acquisition time and requires error correction.

Each communications protocol presents different benefits and disadvantages. Benefits can be increased by merging different protocols, but only to a limited degree. There is a need for a protocol that solves all or most problems, especially those associated with fading.

Summary of the Invention

The principle object of the present invention is to provide a protocol that achieves the combined benefits of the previously mentioned protocols. Another object is to present a spread-spectrum protocol that is specifically designed for mobile communications. These objects are accomplished by interferometry of multiple carriers. The protocol enabled by the present invention is Carrier Interference Multiple Access (CIMA). In CIMA, the frequency and phase of each carrier is selected so that the superposition of the signals results in a pulse (constructive interference resulting from a zero-phase relationship between the carriers) that occurs in a specific time interval. The resulting signal has side lobes whose amplitudes are far below the amplitude of the pulse. Thus, orthogonality is achieved in the time domain.

Because the carriers exist within the time interval where superposition yields a negligible signal level, it can be concluded that the pulse exists in a different phase space. This phase space is defined as a time (phase) offset between the carriers. The offset enables the pulse to be observed in a specific time interval. A receiver tuned to multiple phase spaces can generate multiple samples of the CIMA signal. Thus, CIMA enables signals to be processed simultaneously as both low and high data-rate signals. This mitigates the multipath problems inherent in both classes of signals and enables the system to function with substantially reduced signal power levels. Furthermore, if the CIMA carriers are pulse-amplitude modulated such that the superposition does not result in a pulse in zero-phase space, then the CIMA signals are visible only to CIMA receivers tuned to a nonzero-phase space. Conventional radio receivers can not detect these signals.

In a dispersive medium, such as an optical fiber, the phase space of a CIMA transmission may be selected to match the chromatic dispersion along a predefined length of the medium. The effect of the dispersion is that the phases of the carriers align, resulting in a pulse occurring in the medium at a predefined position.

The time-dependent nature of CIMA phase space also enables automatic scanning of an antenna array's beam pattern. If each element of an antenna array transmits a CIMA carrier, the array's beam pattern scans with a period that depends on the frequency spacing of the carriers and the separation between the antenna elements.

CIMA may be used to create any of the protocols previously mentioned. It is an objective of the present invention to provide methods and apparatus for transmitting and receiving CIMA signals. To this end, the following objectives are achieved:

An objective of the invention is to reduce the effects of multipath fading and interference. A consequence of this objective is the reduction in required transmission power.

Another objective is to provide secure communications by creating transmissions that are difficult to intercept because they are nearly impossible to detect. The low power requirements of the carriers and the transmission of the carriers in nonzero-phase spaces accomplish this.

Another objective of the invention is to reduce interference to other systems and minimize the susceptibility of the communication system to all types of radio interference.

Another objective of the invention is to minimize and compensate for co-channel interference that occurs when the communication system serves multiple users.

Another objective is to provide a spread-spectrum communication protocol that is not only compatible with adaptive antenna arrays, but enables substantial advances in antenna-array technologies.

Another objective is to enable a spread-spectrum communication system to have the performance benefits of a resource-limited system, the capacity and graceful degradation benefits of an interference-limited system, and the ability to provide the benefits of both systems simultaneously. Further objectives and benefits of the invention will become apparent in the Description of the Preferred Embodiments.

Brief Description of the Drawings

FIG. 1 is a schematic of a transmitter that generates CIMA signals.

FIG. 2 is a second embodiment of a transmitter that generates CIMA signals.

5 FIG. 3 is a schematic of a transmitter that generates CIMA carriers emitted by an antenna array.

FIG. 4 is a plot of a plurality of CIMA carriers and a superposition of the carriers.

FIG. 5A is a plot of eight CIMA carriers that shows the relative phases between the carriers as a function of time and illustrates the phase spaces represented by the relative phases.

FIG. 5B is a time-domain plot of a superposition of the carrier signals shown in FIG. 5A.

10 FIG. 6 is a polar plot in time of a superposition of the carriers shown in FIG. 5A.

FIG. 7 is a flow diagram for a receiver that receives a CIMA signal and samples the signal in multiple phase spaces.

FIG. 8 shows part of a frequency profile for a group of CIMA carriers.

FIG. 9A through 9I shows a beam pattern produced by the transmitter in FIG. 3 at different times.

15 FIG. 10 is a frequency-shifted feedback cavity that includes a traveling-wave cavity and a frequency-shifting device through which optical signals are circulated.

FIG. 11 shows different CIMA signals as they propagate down an optical fiber where the phase offsets of the carriers are matched to the chromatic dispersion properties of the fiber.

20 FIG. 12A is a plot of the relative frequency-versus-amplitude profile of CIMA carriers that generate a direct sequence CDMA chip sequence in the time domain.

FIG. 12B is a time-domain representation of a direct sequence CDMA signal generated by the CIMA carriers shown in FIG. 12A.

Description of the Preferred Embodiments

25 FIG. 1 shows a flow diagram of a CIMA transmitter that converts a baseband information signal for a single user k to a CIMA signal for transmission. Data received from an input data source 12 modulates a number N of CIMA carriers, which have different carrier frequencies. This modulation occurs at a plurality of carrier mixers 14n. In this case, the frequencies of the CIMA signals are incrementally spaced by a shift frequency f_s . However, non-uniform spacing of the frequencies may also
 30 be used to achieve specific benefits described in U.S. Pat. Appl. #09/022,950, which is incorporated herein by reference. The carrier frequencies are typically chosen to be orthogonal to each other:

$$\int_0^{T_c} \cos(\omega_i t + \phi_i) \cos(\omega_j t + \phi_j) dt = 0$$

where T_c is the chip duration, ω_i and ω_j are the i^{th} and j^{th} carrier frequencies, and ϕ_i and ϕ_j are arbitrary phases. A signal in the j^{th} frequency band does not cause interference in the i^{th} frequency band. However,
 35 orthogonality of the waveforms is not required if the signals transmitted are resource limited.

The phase of each CIMA signal is set with respect to a predetermined receiver time interval and phase space in which the CIMA signals constructively combine when received by a CIMA receiver. An incremental phase offset of $e^{in\Delta\phi_k}$ is applied to each CIMA carrier by one of a plurality N of user-interval delay systems 16n. Each CIMA carrier has its gain adjusted by an amplitude-control system 18n. The amplitude control 18n provides a gain profile to the CIMA signals. This profile may include a tapered-amplitude window with respect to the frequency domain, compensation for flat fading of CIMA carriers in the communications channel, and pulse-amplitude modulation of the CIMA carriers (which limits the existence of the carriers to temporal regions near a predetermined receiver time interval for each carrier). The gain-adjusted CIMA signals are summed by a combining system 20. A frequency converter 22 may be used to convert the CIMA signals to the appropriate transmit frequencies, which are conveyed to a output coupler 24.

The output coupler 24 is any device that couples CIMA transmit signals into a communications channel from which CIMA signals are received by a receiver. For radio communications, the output coupler 24 may include one or more antenna elements (not shown). For optical communications, the output coupler 24 may be a lens or simple coupling element that couples light into an optical fiber. Although this diagram illustrates the generation of CIMA transmission signals as step-by-step procedures, a preferred embodiment for accomplishing these processes is to use digital signal-processing techniques, such as Discrete Fourier Transforms.

The order of some of these processes may be switched. For example, modulation of each CIMA carrier by the input data may be the final step before combining. FIG. 2 shows a flow diagram for generating CIMA signals. Each of these processes is similar to the processes shown in FIG. 1. The difference between the diagrams is that in FIG. 2, the CIMA signals are not combined until they are transmitted into the communications channel. An illustration of this is shown in FIG. 3.

FIG. 3 shows a data stream from the data source 12 being used to modulate a plurality of CIMA carriers at a plurality of mixers 25n. A CIMA carrier with a specific frequency, phase relationship and gain profile is input to each mixer 25n. Each bit from the data source 12 modulates all of the CIMA carriers. Each mixer 25n is connected to one of a plurality of antenna-array elements 24n; thus, each antenna element 24n transmits only one CIMA carrier. Although the collection of CIMA carriers has data redundancy due to the same bit being modulated onto multiple carriers, the frequency and phase relationships between the carriers cause orthogonality in time (illustrated by the Inverse Fourier Transform of the CIMA carriers in the frequency domain). This orthogonality negates the typical decrease in bandwidth efficiency caused by data redundancy and retains the benefits of frequency diversity. The orthogonality results from constructive and destructive interference between the CIMA carriers. Constructive interference causes narrow time-domain pulses with a repetition rate proportional to the inverse of the carrier-frequency spacing f_s .

FIG. 4 illustrates how the phase fronts of CIMA carriers are aligned at a specific time. At other times, the carriers combine destructively resulting in undetectable signal levels. A composite signal 130 results from the summation of the carriers. The composite signal 130 shows a pulse envelope occurring in a predetermined time interval 135. In the case where there is no amplitude tapering (i.e., a rectangular window) and the CIMA carriers are uniformly spaced in frequency, a composite CIMA signal is:

$$e(t) = \sum_{n=1}^N e^{i[(\omega_c + n\omega_s)t + n\Delta\phi]}$$

which has a magnitude of:

$$|e(t)| = \left| \frac{\sin(N(\omega_s t + \Delta\phi)/2)}{\sin((\omega_s t + \Delta\phi)/2)} \right|$$

The CIMA signals are periodic with period $1/f_s$ for odd number of carriers N and with period $2/f_s$ for even number of carriers N . The main lobe has duration $2/Nf_s$ and the $N-2$ side lobes each has a duration $1/Nf_s$. The amplitude of the l^{th} side lobe with respect to the main lobe amplitude is:

$$A(l) = \frac{1}{N \sin(\pi(l+1/2)/N)}$$

Because the period and width of the pulse envelope depends on the amplitude, phase, and frequency separation of the CIMA carriers, the frequency of each carrier may be changed without affecting the pulse envelope as long as the amplitude, phase, and frequency separation are preserved. Thus, frequency hopping and frequency shifting of the carriers does not affect the temporal characteristics of the composite signal 130. Providing a tapered amplitude distribution to the CIMA carriers broadens the main lobe width and reduces the amplitude of the side lobes.

FIG. 5A illustrates the phase space of the carriers shown in FIG. 4. As time moves forward, the phase relationship between the CIMA carriers changes. A straight line 113 indicates a zero-phase relationship between the carriers. The sum of the carriers are viewed in a specific phase space. A pulse occurs when there is a zero-phase relationship between all the carriers, yet the carriers can exist in other time domains even if no pulse is visible. When the pulse moves into this phase space (which it does as a periodic function of time), the pulse becomes visible. Zero-phase is the phase space in which all conventional receivers operate. This phase space is illustrated by the sum of carrier amplitudes along any straight line that rotates about a fixed point 112. The sum of the amplitude of the waves along the line 113 as it rotates is shown in FIG. 5B and in a polar plot illustrated by FIG. 6.

In FIG. 5A, a curved line 111 illustrates one of the many phase spaces in which a pulse may be observed. This phase space 111 occurs within a time interval that is bounded by lines 115 and 117. In this time interval, the amplitude of the composite signal 130 (shown in FIG. 5B) is negligible. However, a receiver may tune to a specific phase space by selectively delaying each of the received carriers by a

predetermined amount before summing the carriers. In this way, a receiver may detect a pulse that is otherwise invisible in zero-phase.

FIG. 7 shows a single-user phase-space receiver that is capable of sampling in multiple phase spaces. A received CIMA signal is detected from the communications channel by a receiving element 52 and down-converted by a mixer 54 before being separated into its N component carriers by a frequency filter 56. Depending upon how the transmit signal may have been altered by the communications channel, one of a plurality of gain compensators (not shown) may apply a gain compensation to each component n . Then each gain-compensated component is split into a number M of delay components, each of which is delayed by a phase-space delay compensator 60 m n. The output of each m -numbered delay component is summed at a combining step 62 to reconstruct pulses observed in other phase spaces. Each pulse may be delayed at a delay step 64 m to synchronize the pulses before being summed in a decision step 66 that outputs an estimate of the original transmit signal. In practice, the delay step 64 m may be integrated into the decision step 66.

This receiver obtains multiple samples of the pulse because it tracks the pulse through different phase spaces. Thus, the receiver benefits from the relatively slow data rate (i.e., pulse period) of the CIMA carriers which combine to create the pulses. This remedies the multipath problem of intersymbol interference. The short duration of each pulse allows the receiver to avoid the fading and distortion problems inherent in systems that receive slowly varying signals and the flat fading associated with narrowband signals. Although the pulse is comprised of many narrowband CIMA carriers, flat fading (which causes very deep fades) is avoided because the CIMA pulse depends on the interference pattern between a large number of CIMA carriers. Furthermore, if the number of and spacing between the CIMA carriers are appropriately chosen, it is unlikely that more than one CIMA carrier is located in a deep fade. Thus, frequency diversity is achieved.

Each user k can share the communication resource through a unique selection of the phase offset (i.e., timing offset) while employing the same carriers as other users. If N orthogonal carriers are shared by each user k , then N users may use the resource without co-channel interference. In this case, there is a unique combination of phase space with respect to time for each user k . Similarly, users employing different CIMA carriers may use the same phase space with respect to time without co-channel interference. Because the pulse characteristics depend on the frequency and phase relationships between the CIMA carriers, the frequency and phase of each CIMA signal may be changed without altering the characteristics of the pulse envelope as long as those relationships between the CIMA carriers remain unchanged. This enables a transmitter to frequency hop to avoid interference or enhance security.

Separation f_c between the CIMA carriers for each user may be selected as shown in FIG. 8 such that it exceeds the coherence bandwidth (i.e., the inverse of the multipath duration). This results in frequency nonselective fading over each carrier. If the adjacent CIMA carriers overlap in frequency by 50%, the system capacity increases by two-fold above the classical limitation imposed by non-

overlapping carriers. Such a system does not have independent channel-fading characteristics over each carrier. However, CIMA carriers do not need to be adjacent in frequency. The system can attain N-fold frequency-diversity gain by using a subset of carrier frequencies for each set of users such that the carrier separation f_s for each user k exceeds the coherence bandwidth. For example, in the frequency profile shown in FIG. 8, a set of nonadjacent carrier frequencies 42, 43, and 44 may be selected for a particular group of users. This frequency profile allows both time offsets and frequency division multiplexing to optimize bandwidth efficiency. If the bandwidth of each carrier is small compared to the carrier separation f_s , unauthorized interception of the CIMA signal by a broadband receiver is more difficult. The amount of background noise received by a receiver depends on the bandwidth of the receiver. A CIMA receiver may be tuned to receive CIMA carriers at predetermined narrow bands in which the signal-to-noise ratio (SNR) is relatively large. However, a broadband receiver receives noise components in the spectrum between the CIMA carriers, resulting in a low SNR.

If the number of users k exceeds the number of CIMA carriers N , the timing offset of each user k can be selected to position the CIMA pulses to minimize the mean square cross correlations between the pulses. User signals may also be positioned relative to the type and priority of each user's communication channel. This ensures quality of service for specific users or types of transmissions. This also provides the quality of a resource-limited system when the number of users is at or below the classical limit of a resource-limited system and provides interference-limited operations when demand exceeds the classical limit.

Although the receiver shown in FIG. 7 is described as a single-user receiver, a preferred mode of operation is multi-user detection. Unlike direct-sequence CDMA where each user contributes noise to every other user's communication channel, CIMA limits multi-user interference to user signals (pulses) that are nearby in the time domain. In the preferred mode of operation, the receiver samples adjacent user signals in as few as two neighboring user time intervals. Then it performs a weight and sum in the decision step 66 to cancel those contributions to the intended user's signal.

The separation d between the antenna elements $24n$ of the transmitter 70 (shown in FIG. 3) results in an azimuthal variation of the beam pattern produced by the array $24n$ due to the time-dependent phase-space characteristic of the CIMA signal. In other words, as the phase space of the CIMA signals changes with time, the beam pattern of the array $24n$ scans. The time dependence of the beam pattern's directionality is shown by the following beam-pattern equation:

$$D(t) = \sum_{n=1}^N a_n \cos((\omega_o + n\omega_s)t + 2\pi nd \sin \theta / \lambda_n)$$

where a_n is the amplitude of each CIMA carrier, $\omega_o + n\omega_s$ is the radial frequency of the n^{th} CIMA carrier, λ_n is the CIMA carrier wavelength, θ is the azimuthal angle, and d is the separation between the array elements $24n$. This characteristic of the CIMA beam pattern may further enhance the diversity benefits of CIMA. Prior art shows that changing the beam pattern of a transmitting antenna aids in diversity

reception. Plots of the beam pattern equation $D(t)$ are shown in FIGS. 9A through 9L for $d = \lambda_o / 2$ and incremental values of time t . Different values for separation d result in changes to the number of main lobes and the rate at which they scan. Adjusting the frequency separation f_s changes the directionality $D(t)$.

5 FIG. 10 shows a frequency-shifted feedback cavity (FSFC) 70 that can be used to generate CIMA signals. A base-frequency generator 72 produces an optical base frequency f_o signal from which frequency-shifted signals are created. The base-frequency signal is input to a travelling-wave cavity 74 that includes a frequency shifter 76. The frequency shifter 76 may be an acousto-optic modulator (AOM). As light circulates through the cavity 74, it is shifted in frequency by an amount f_s each time it passes
10 through the frequency shifter 76. The travelling-wave cavity 74 does not selectively attenuate frequencies. Rather, the oscillations it supports are characterized by an unusually broad spectral output, that has no mode structure. A portion of the light is output from the cavity to a multicarrier processor 78. For example, an AOM (not shown) diffracts light passing through it; the light is then fed back into the cavity 74. An undiffracted portion of the beam provides a convenient output. The output of the processor 78 is
15 conveyed to an output coupler (not shown), for example, an antenna, a focusing element, or a connector to an optical fiber.

The output beam consists of multiple beams of incrementally delayed, frequency-shifted light. The amount of delay incurred by each output beam component is identified by the frequency of the component. If the cavity 74 does not cause the light to undergo a significant amount of chromatic
20 dispersion, the amount of delay incurred by an output component is substantially proportional to the amount of frequency shift the beam has incurred. The multicarrier processor 78 may include diffractive optics to wavelength demultiplex the output components. If the base-frequency generator 72 modulates the optical base signal with an information signal, the output of the multicarrier processor 78 includes multiple delayed (and separated) versions of the modulated signal. Each of the delayed versions of the
25 modulated signal may be used to modulate a transmit signal emitted by each of the antenna array elements 24n shown in FIG. 3. If each array element 24n emits a transmit signal having the same distribution of frequencies, the directionality of the beam pattern produced by the array 24n does not change in time. Rather, the directionality can be adjusted simply by changing the length of the travelling-wave cavity 74.

30 The FSFC 70 may also be used as a receiver for sampling received CIMA signals in nonzero-phase spaces. This requires that the frequency shift f_s by the frequency shifter 76 match the frequency separation of the received CIMA signals. Light output from the FSFC 70 is separated by wavelength to identify the different phase-space samples of the received CIMA signal. These phase spaces will be substantially linear if the cavity 74 does not cause chromatic dispersion. Linear phase space sampling
35 matches the phase spaces of the received signals provided that $f_o \gg N * f_s$.

The FSFC 70 shown in FIG. 10 may be used to generate CIMA signals for transmission through an optical fiber or waveguide. In this mode of operation, the frequency generator 72 produces an unmodulated optical base signal. The output of the travelling-wave cavity 74 is a collinear superposition of CIMA carriers and is easy to couple into an optical fiber. Thus, the multicarrier processor 78 does not separate the components. The multicarrier processor 78 modulates the CIMA signals with an information signal that has a predefined duration in the time domain. The timing and duration of the information signal can be chosen to compensate for chromatic dispersion of the CIMA carriers as they propagate through the fiber.

Chromatic dispersion occurs in an optical fiber as different wavelengths of light travel at different speeds. Optical fiber has different indices of refraction for different wavelengths of light. The speed of light in the material is inversely proportional to the index of refraction. In material dispersion, light with a long wavelength travels faster than light with a shorter wavelength. This causes distortion (broadening) of optical pulses transmitted through an optical fiber.

FIG. 4 shows the phase relationship between CIMA carriers as a CIMA signal propagates in a nondispersive medium. As the CIMA carriers propagate through space, CIMA pulses do not distort because the phase relationships between the carriers do not change except for their periodic relationship. For example, a receiver moving at the speed of the carriers detects no changes in the relative phase of the carriers. Another way of describing this is that two stationary receivers may be spaced apart by an integer number of pulse periods, and they detect the same phase relationships between the CIMA carriers. However, in a dispersive medium, the two stationary detectors detect different phase relationships because some of the carriers have traveled further in phase. The following equation shows the difference in wavelength between adjacent CIMA carriers:

$$\Delta\lambda = \frac{cf_s}{f_o(f_o + f_s)}$$

This is a nonlinear relationship in which the wavelength difference $\Delta\lambda$ between adjacent CIMA carriers increases as the wavelength of each carrier increases. This is illustrated by a phase profile 123 of carrier maxima in FIG. 4. The frequency separation f_s is selected with respect to the dispersion characteristics of an optical fiber 150 to match the velocity profile of the carriers with their phase profile. Then portions of the carriers are selected to constructively combine to create CIMA pulses at predetermined locations along the fiber 150.

The CIMA carriers are pulse-amplitude modulated in a time interval 133 in which the phase profile 123 occurs. In that time interval 133, the composite signal 130 resulting from the sum of the carriers is negligible. As the carriers propagate through the fiber 150, the relative phases of the carriers change. During a later time interval 135, the carrier signal phases line up at a specific time 125, which results in constructive interference that causes a pulse to occur in the composite signal 130. At later time

intervals 127 and 129, the low-wavelength carriers have traveled slightly farther, resulting in distorted phase profiles 137 and 139, respectively. The composite signal 130 in these time intervals returns to zero.

FIG. 11 shows a plurality of composite CIMA signals along a dispersive optical fiber 150. Three signals 160, 170, and 180 are input at one end of the fiber 150. The phase profile of the first signal 160 is selected such that the CIMA carriers combine constructively to produce a pulse 161 at a first node 151. The first CIMA carriers 160 combine destructively to produce low-level signals 162 and 163, at second and third nodes 152 and 153, respectively. Similarly, the carrier phases of the second signal 170 are selected to produce a constructively interfering signal 172 at the second node 152. Likewise, the carrier phases of the third signal 180 are selected to provide constructive interference 183 at the third node 153. By making use of the nonlinear dispersion of light in an optical fiber, it may be possible to expand the usable bandwidth of the optical fiber beyond classical limitations.

FIG. 12A shows an amplitude distribution for twenty CIMA carriers. These carriers produce a combined signal shown in FIG. 12B consisting of a pseudo-random sequence of positive and negative CIMA pulses. Thus, a particular distribution of carrier amplitudes in the frequency domain results in a direct-sequence CDMA code that is periodic in the time domain. When CIMA signals are used as the basis for a CDMA system, the CDMA system gains the advantages of reduced multipath and intersymbol interference, increased capacity, and reduced co-channel interference. Because CIMA signals are sinc functions, they have high autocorrelation efficiency. The autocorrelation function falls off rapidly when synchronization is lost.

The preferred embodiments demonstrate a few of the many methods for generating and receiving CIMA signals. This was done to provide a basic understanding of the characteristics of CIMA. With respect to this understanding, many aspects of this invention may vary; for example, the methods used to create and process CIMA signals. It should be understood that such variations fall within the scope of the present invention, its essence lying more fundamentally with the design realizations and discoveries achieved than the particular designs developed.

The foregoing discussion and the claims that follow describe the preferred embodiments of the present invention. Particularly with respect to the claims, it should be understood that changes might be made without departing from the essence of the invention. In this regard, it is intended that such changes still fall within the scope of the present invention. To the extent such revisions utilize the essence of the present invention, each naturally falls within the breadth of protection encompassed by this patent. This is particularly true for the present invention because its basic concepts and understandings are fundamental in nature and can be broadly applied.

I claim:

1. A method of communication between at least one transmitter and one receiver using carrier-interference multiple-access (CIMA) communication signals, the method comprising the steps of:
 - 5 • providing for the generation of a plurality of electromagnetic carrier signals for use by at least one user, the carrier signals having a plurality of frequencies,
 - providing a relative phase to the carriers to produce a predefined phase relationship at a predetermined time,
 - providing modulation of the carrier signals by an information signal,
 - 10 • providing for transmission of the modulated, phased carrier signals into a communications channel to produce CIMA transmit signals having carrier-signal components, and
 - providing for reception of the CIMA transmit signals from the channel wherein the carrier-signal components are combined in phase to produce at least one constructive-interference pulse that is indicative of the information signal.
- 15 2. The method of communication recited in claim 1 wherein the carrier signals are incrementally spaced in frequency.
3. The method of communication recited in claim 1 wherein the step of providing for the generation of a plurality of electromagnetic carrier signals includes the generation of a plurality of groups of carriers having identical sets of carrier frequencies, each group being assigned to one of a plurality of users,
20 and the step of providing a relative phase to the carriers includes providing a unique relative phase to the carriers of each group wherein each group has a unique time offset in order to generate pulses that are received at different time intervals.
4. The method of communication recited in claim 1 wherein the step of providing for the generation of a plurality of electromagnetic carrier signals includes the generation of a plurality of groups of carriers,
25 each group having a unique set of carrier frequencies and being assigned to at least one user, and the step of providing a relative phase to the carriers includes providing a relative phase to each group such that a plurality of users receives pulses in the same time interval but each user uses different carrier frequencies.
5. The method of communication recited in claim 1 wherein the step of providing for the generation of a plurality of electromagnetic carrier signals having a plurality of frequencies includes the step of
30 providing variations to the carrier frequencies with respect to time wherein the frequency variations for each carrier in a group of carriers corresponding to each user are substantially identical, thereby causing little or no change to the envelope of the pulse.
6. The method of communication recited in claim 1 wherein the step of providing modulation of the
35 carrier signals comprises pulse amplitude modulation being applied to a plurality of the carriers, the

pulse amplitude modulation having a duration that is longer than the pulse width of the constructive-interference pulse.

7. The method of communication recited in claim 1 wherein the step of providing modulation of the carrier signals comprises pulse amplitude modulation being applied to a plurality of the carriers, the pulse amplitude modulation having a duration that is shorter than the period of the constructive-interference pulse.
8. The method of communication recited in claim 1 wherein the step of providing for the generation of a plurality of electromagnetic carrier signals includes tapering the frequency-versus-amplitude window of the carrier signals to reduce time-domain side-lobe energy of the constructive-interference pulse.
9. The method of communication recited in claim 1 wherein the step of providing for reception of the CIMA transmit signals includes the step of providing a number of predetermined delays to each received carrier signal before combining to produce the constructive-interference pulse where the number of predetermined delays is equal to the number of different phase spaces in which the received CIMA transmit signal is sampled.
10. The method of communication recited in claim 1 wherein the step of providing modulation of the carrier signals by an information signal is performed in a specific time interval relative to the phase of the carriers such that the resulting modulated carriers occupy one or more nonzero-phase spaces and do not combine constructively in zero-phase space to produce a pulse.
11. The method of communication recited in claim 1 wherein the step of providing for reception of the CIMA transmit signals includes compensating for the relative phases of the carriers in at least one of the nonzero-phase spaces in order to combine the carrier signals in phase.
12. The method of communication recited in claim 9 wherein multi-user interference is sampled in the different phase spaces and then weighted and combined with an intended user signal to cancel contributions of the multi-user interference to the intended user signal.
13. The method of communication recited in claim 1 wherein the step of providing for the generation of a plurality of electromagnetic carrier signals is performed by a frequency-shifted feedback cavity.
14. The method of communication recited in claim 1 wherein the step of providing for reception of the CIMA transmit signals is performed by a frequency-shifted feedback cavity.
15. The method of communication recited in claim 1 wherein the communications channel is a waveguide.
16. The method of communication recited in claim 15 wherein the electromagnetic carrier signals are optical signals and the waveguide is an optical fiber.
17. The method of communication recited in claim 15 wherein the steps of providing for the generation of a plurality of electromagnetic carrier signals and providing a relative phase to the carriers to produce a predefined phase relationship are performed to match the relative phases between the carriers to the chromatic dispersion profile of the carriers in the waveguide such that the dispersion

causes the carrier phases to have a predetermined phase relationship after propagating a predetermined distance in the waveguide.

18. The method of communication recited in claim 1 wherein the step of providing for transmission of the modulated, phased carrier signals includes transmitting the carriers from a transmitter array wherein each carrier for a particular user is transmitted from a separate transmitter element of the array and an array beam pattern is generated from the superposition of transmitted carriers from each of the transmitter elements.
19. The method of communication recited in claim 18 wherein a separation between the transmitter elements is selected with respect to the carrier frequency separation to control the shape of the array beam pattern and the period in which the array beam pattern scans.
20. The method of communication recited in claim 1 wherein the step of providing a relative phase to the carriers results in a train of pulses in the time domain and the step of providing modulation of the carrier signals results in modulating each of the pulses with a direct sequence chip such that the modulated train of pulses is a direct-sequence code.
21. The method of communication recited in claim 20 wherein the direct-sequence chip is the product of an information signal and a chip of a pseudo-random CDMA spreading code.
22. The method of communication recited in claim 1 wherein the step of providing for reception of the CIMA transmit signals includes multi-user detection in which user signals from an intended user and at least one interfering user are received where the interfering user signals are weighted and combined with the intended user's signal to cancel the interfering user signals to the intended user's signals.
23. The method of communication recited in claim 1 wherein the step of providing a relative phase to the carriers to produce a predefined phase relationship at a predetermined time results in at least two received constructive-interference pulses that overlap in time.
24. The method of communication recited in claim 1 wherein the step of providing a relative phase to the carriers to produce a predefined phase relationship at a predetermined time includes a decision step that allows for at least two received constructive-interference pulses to overlap in time when the number of users or channel usage increases beyond a predetermined limit.
25. The method of communication recited in claim 24 wherein the decision step includes a step of identifying the users and assigning a priority to each user that is used to determine which user signals are be selected to overlap in time.
26. The method of communication recited in claim 1 wherein the carrier frequencies for each user are separated by an amount that is equal to or greater than the coherence bandwidth of the communication channel.
27. A carrier-interference multiple-access (CIMA) communication system for providing communication between at least one transmitter and one receiver comprising:
- a CIMA transmitter comprising:

- a multicarrier generator for generating a plurality of electromagnetic carrier signals for use by at least one user where the carrier signals are incrementally separated in frequency,
 - a delay controller to cause a predefined phase relationship between the carriers at a predetermined time,
 - 5 - a carrier modulator to modulate the carrier signals with an information signal, and
 - an output coupler for coupling the modulated, phased carrier signals into a communications channel to produce CIMA transmit signals having carrier-signal components
 - a CIMA receiver for receiving the CIMA transmit signals from the channel, providing a predetermined delay to each of the carrier signal components and combining the carrier-signal components in phase to produce at least one constructive-interference pulse that is indicative of
10 the information signal.
28. The CIMA communication system claimed in Claim 27 wherein the CIMA receiver samples within at least one predetermined time interval to receive at least one pulse in zero-phase space.
29. The CIMA communication system claimed in Claim 27 wherein the CIMA receiver samples a user
15 signal in a plurality of phase spaces at different times and combines the samples in a signal estimator that estimates the information signal.
30. The CIMA communication system claimed in Claim 27 wherein the CIMA receiver is a multi-user detector that samples one or more interfering user signals that interfere with an intended user's signal, weights the sampled interfering signals, and combines the sampled interfering signals with the
20 intended user's signal to cancel multi-user interference.
31. The CIMA communication system claimed in Claim 27 wherein the multicarrier generator is a frequency-shifted feedback cavity.
32. The CIMA communication system claimed in Claim 27 wherein the communications channel is a waveguide.
- 25 33. The CIMA communication system claimed in Claim 27 wherein the output coupler is an array of transmitters.
34. The CIMA communication system claimed in Claim 33 wherein each element of the array transmits a separate carrier signal for each user, thereby creating a time-dependent beam pattern for each user, and the multicarrier generator controls the frequency separation of the carriers to control the scan rate
30 of each beam pattern.
35. The CIMA communication system claimed in Claim 27 wherein the carrier signals are non-uniformly separated in frequency.
36. The CIMA communication system claimed in Claim 27 wherein one or more functions of at least one of the transmitter and the receiver are performed by digital signal processing.
- 35 37. The CIMA communication system claimed in Claim 27 wherein the receiver provides gain adjustment to at least one of the carrier signal components to compensate for flat fading.

38. The CIMA communication system claimed in Claim 27 wherein the multicarrier generator provides a tapered amplitude to the carriers to reduce sidelobes.
39. The CIMA communication system claimed in Claim 27 wherein the carrier modulator applies pulse-amplitude modulation to the carrier signals.
- 5 40. The CIMA communication system claimed in Claim 39 wherein the pulse-amplitude modulation is applied in a predetermined time interval relative to the phases of the carriers to produce one or more CIMA transmit signals that occupy one or more nonzero phase spaces and do not combine constructively in zero-phase space.
- 10 41. The CIMA communication system claimed in Claim 40 wherein the communications channel is a waveguide and the frequency separation and the relative phases of the carriers within a pulse-amplitude modulated envelope are selected to match the chromatic dispersion of the waveguide for causing a predetermined phase relationship between the carriers to occur after propagating a predetermined distance in the waveguide.
- 15 42. The CIMA communication system claimed in Claim 27 wherein the receiver is a frequency-shifted feedback cavity.
43. The CIMA communication system claimed in Claim 27 wherein the multicarrier generator provides a predetermined amplitude to each carrier signal to generate a train of pulses having a direct-sequence modulation.

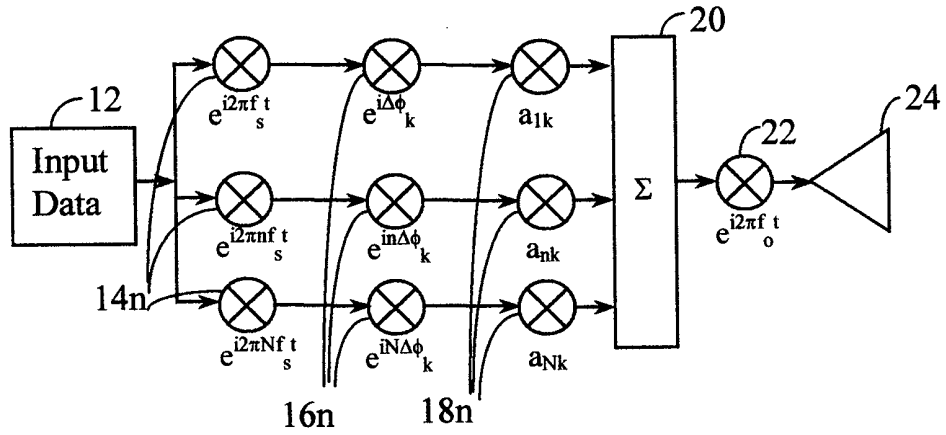

FIG. 1

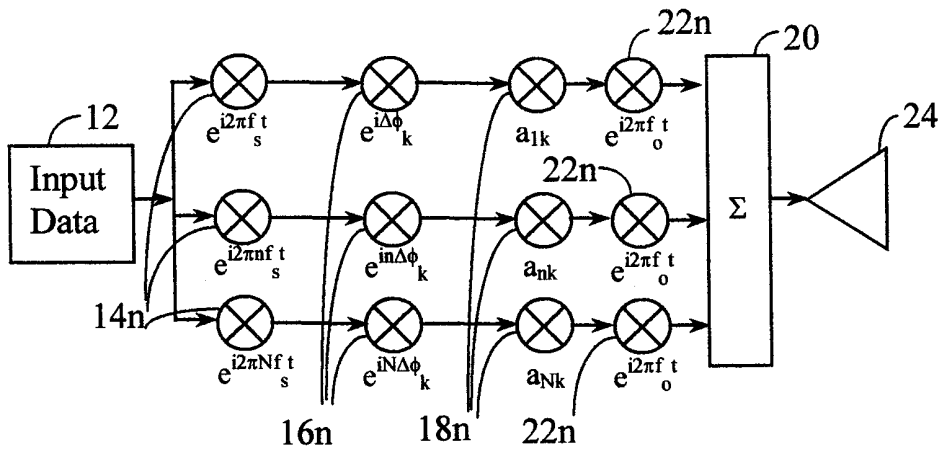

FIG. 2

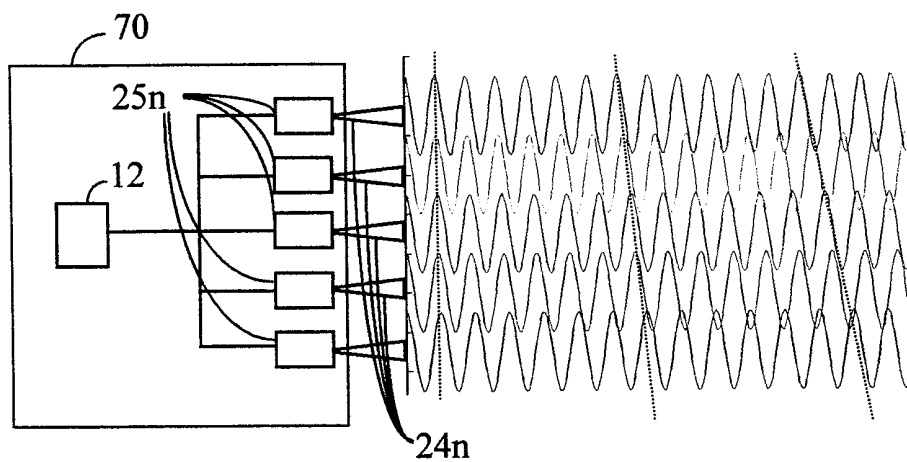

FIG. 3

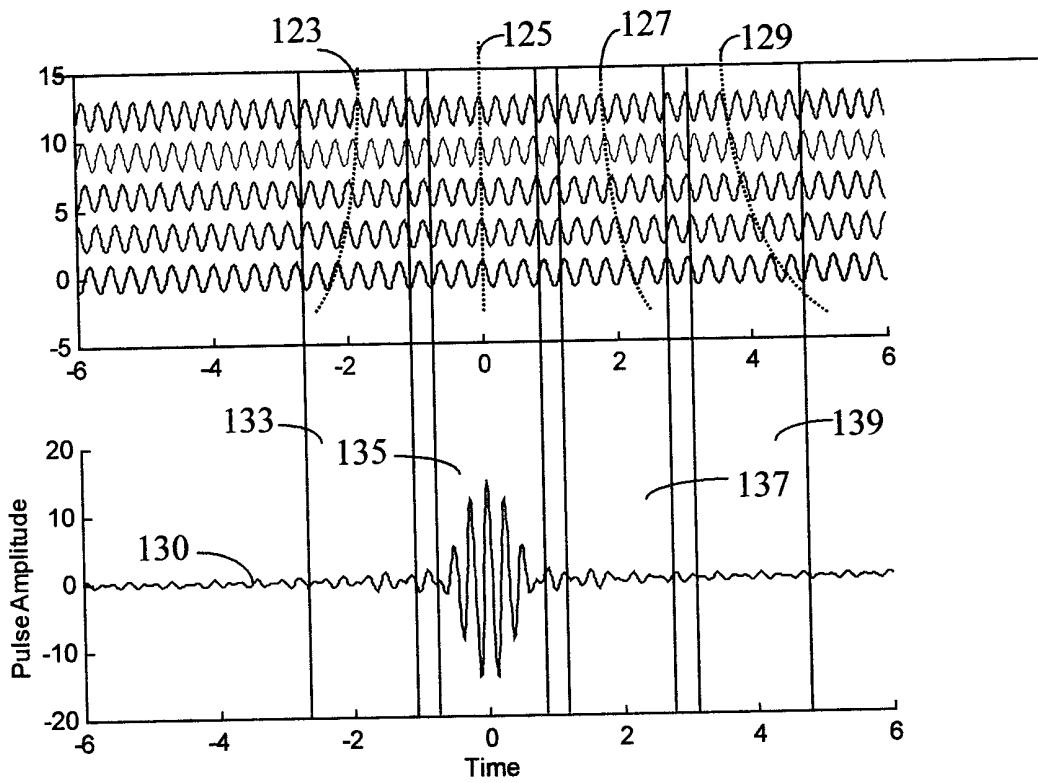

FIG. 4

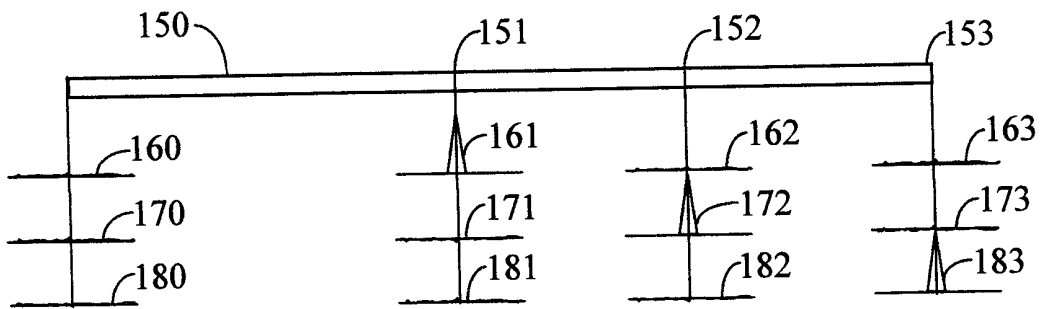

FIG. 11

3/7

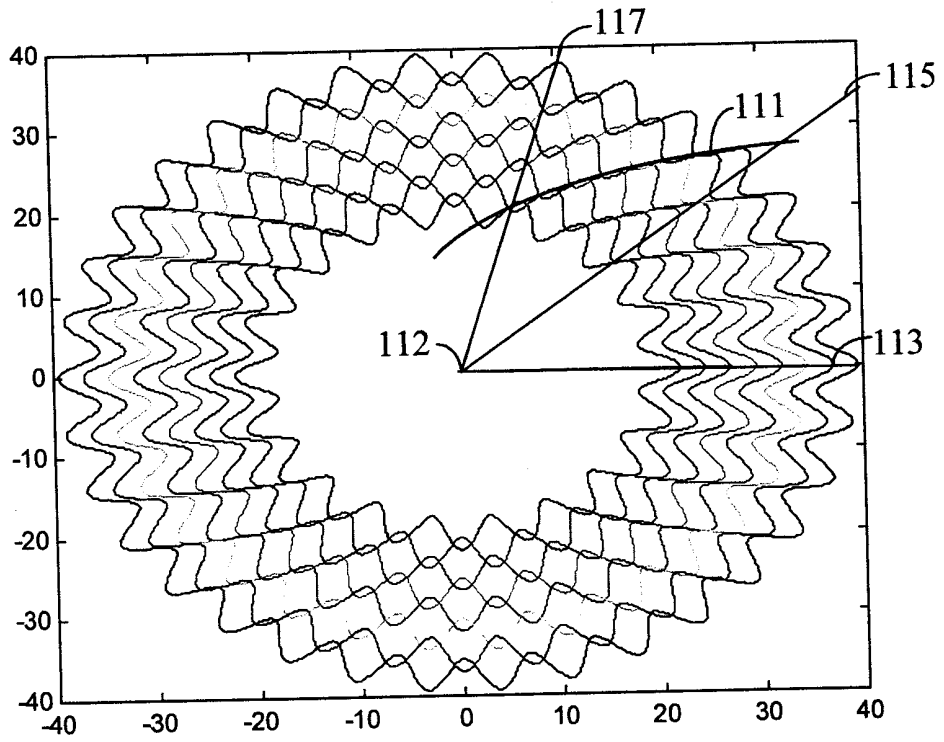

FIG. 5A

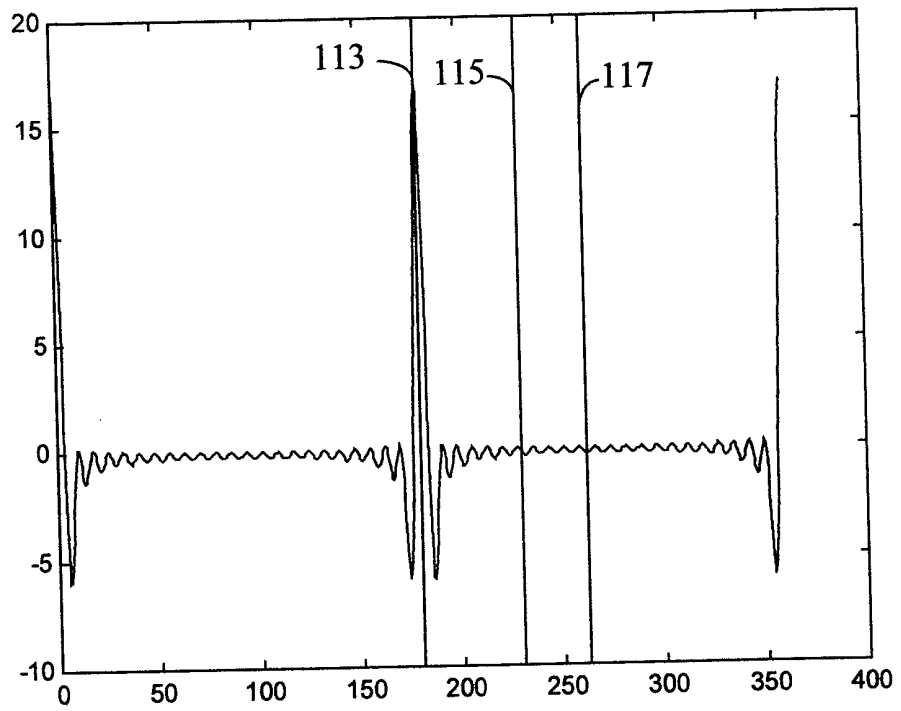

FIG. 5B

4/7

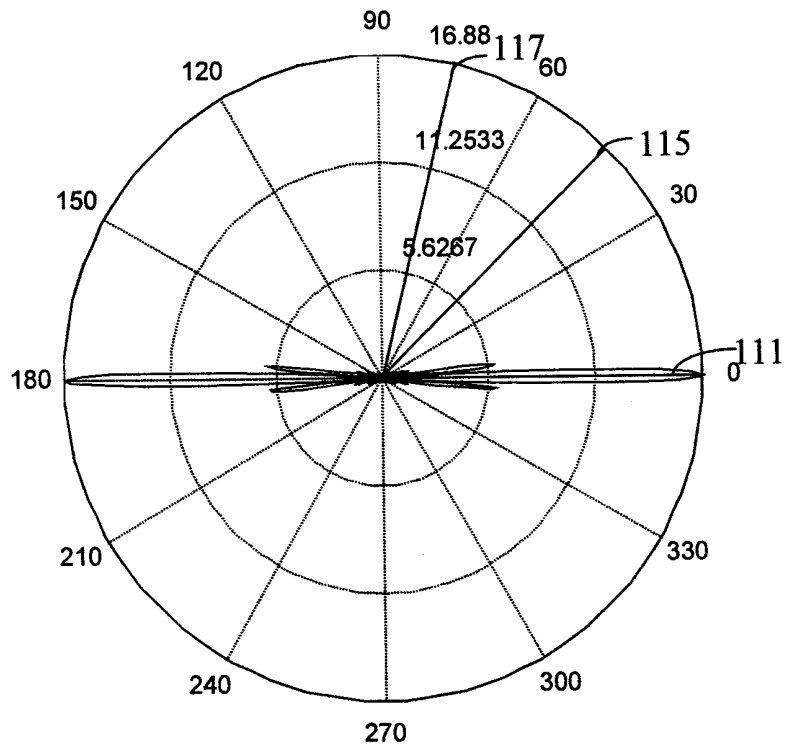

FIG. 6

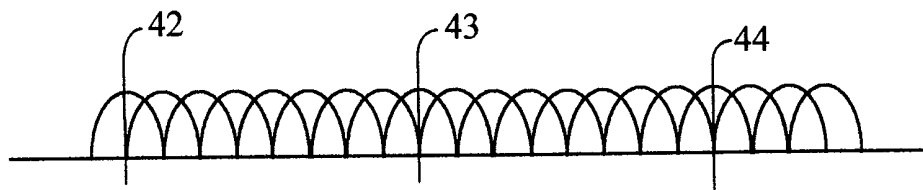

FIG. 8

5/7

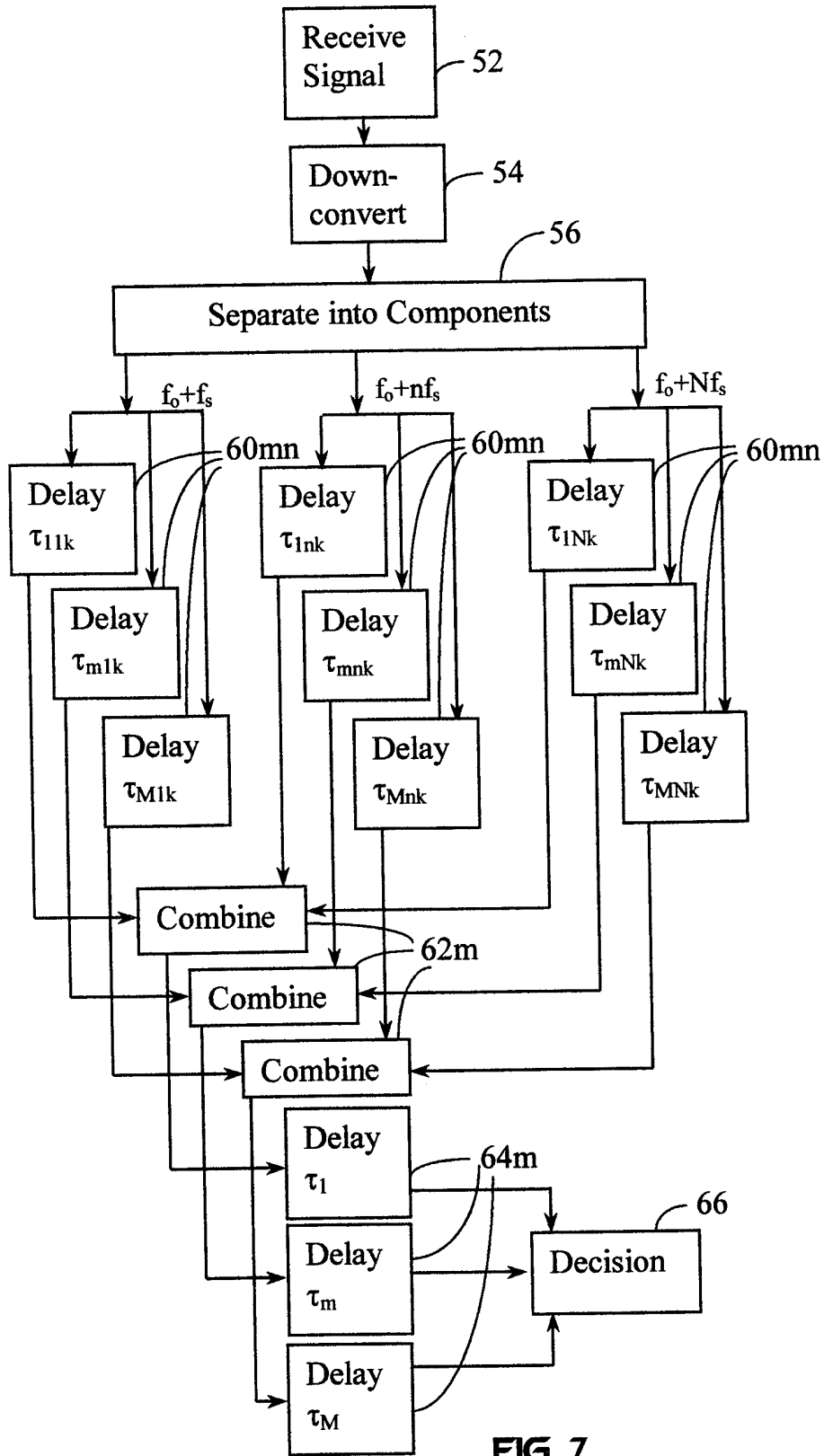

FIG. 7

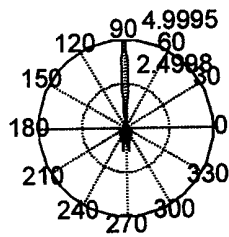

FIG. 9A

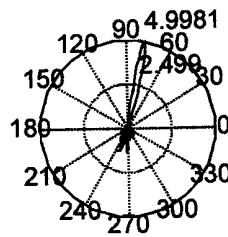

FIG. 9B

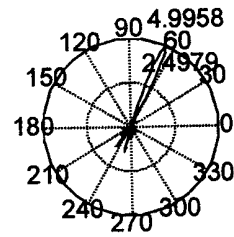

FIG. 9C

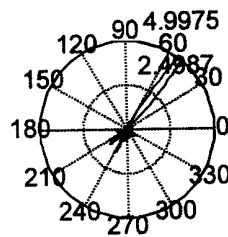

FIG. 9D

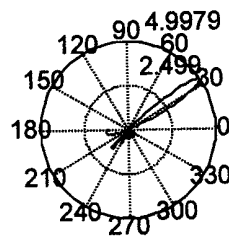

FIG. 9E

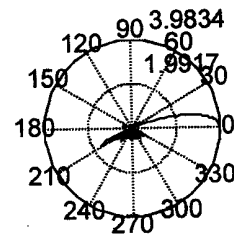

FIG. 9F

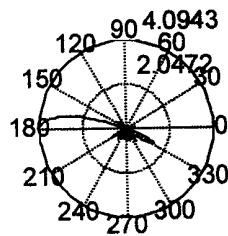

FIG. 9G

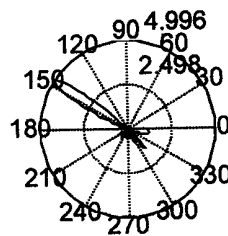

FIG. 9H

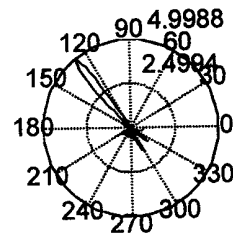

FIG. 9I

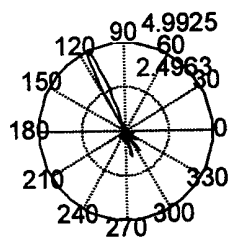

FIG. 9J

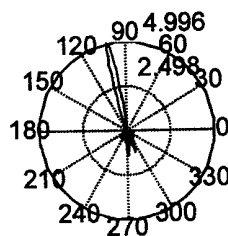

FIG. 9K

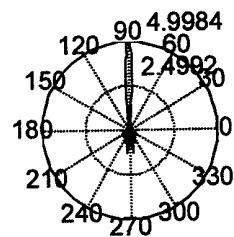

FIG. 9L

7/7

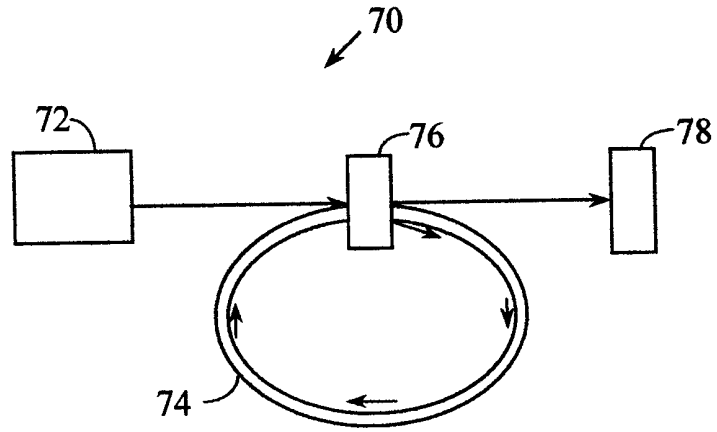

FIG. 10

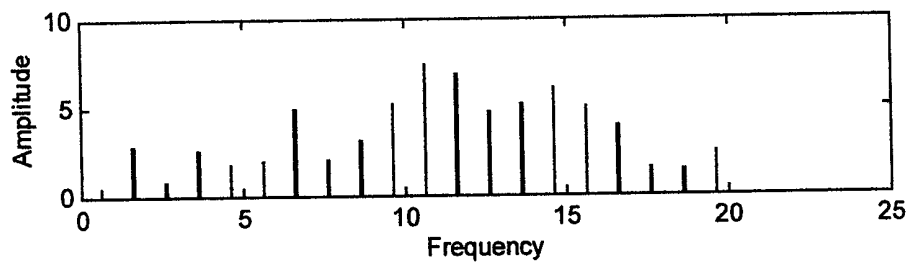

FIG. 12A

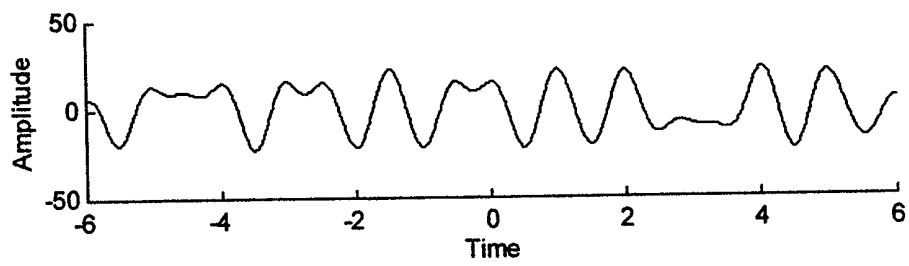

FIG. 12B

INTERNATIONAL SEARCH REPORT

International Application No

PCT/US 99/02838

A. CLASSIFICATION OF SUBJECT MATTER

IPC 6 H04L1/04

According to International Patent Classification (IPC) or to both national classification and IPC

B. FIELDS SEARCHED

Minimum documentation searched (classification system followed by classification symbols)

IPC 6 H04L H04B

Documentation searched other than minimum documentation to the extent that such documents are included in the fields searched

Electronic data base consulted during the international search (name of data base and, where practical, search terms used)

C. DOCUMENTS CONSIDERED TO BE RELEVANT

Category °	Citation of document, with indication, where appropriate, of the relevant passages	Relevant to claim No.
X	<p>US 5 563 906 A (HERSHEY ET AL) 8 October 1996</p> <p>see column 2, line 47 - column 3, line 9 see column 6, line 38 - line 41 see column 4, line 30 - column 5, line 21 see figures 2,3 see claim 1</p> <p style="text-align: center;">--- -/--</p>	<p>1-7, 9-12, 15, 16, 27-30, 35, 36, 39, 40</p>

Further documents are listed in the continuation of box C.

Patent family members are listed in annex.

° Special categories of cited documents :

- "A" document defining the general state of the art which is not considered to be of particular relevance
- "E" earlier document but published on or after the international filing date
- "L" document which may throw doubts on priority claim(s) or which is cited to establish the publication date of another citation or other special reason (as specified)
- "O" document referring to an oral disclosure, use, exhibition or other means
- "P" document published prior to the international filing date but later than the priority date claimed

- "T" later document published after the international filing date or priority date and not in conflict with the application but cited to understand the principle or theory underlying the invention
- "X" document of particular relevance; the claimed invention cannot be considered novel or cannot be considered to involve an inventive step when the document is taken alone
- "Y" document of particular relevance; the claimed invention cannot be considered to involve an inventive step when the document is combined with one or more other such documents, such combination being obvious to a person skilled in the art.
- "&" document member of the same patent family

Date of the actual completion of the international search

7 June 1999

Date of mailing of the international search report

14/06/1999

Name and mailing address of the ISA

European Patent Office, P.B. 5818 Patentlaan 2
NL - 2280 HV Rijswijk
Tel. (+31-70) 340-2040, Tx. 31 651 epo nl,
Fax: (+31-70) 340-3016

Authorized officer

Ghigliotti, L

INTERNATIONAL SEARCH REPORT

International Application No

PCT/US 99/02838

C.(Continuation) DOCUMENTS CONSIDERED TO BE RELEVANT

Category °	Citation of document, with indication, where appropriate, of the relevant passages	Relevant to claim No.
X	<p>US 5 519 692 A (HERSHEY ET AL) 21 May 1996</p> <p>see column 3, line 60 - column 4, line 67 see column 6, line 7 - column 7, line 44 see figure 2</p> <p style="text-align: center;">---</p>	<p>1-7, 9-12, 15, 16, 27-30, 35, 36, 39, 40</p>
A	<p>US 4 628 517 A (SCHWARZ ET AL) 9 December 1986 see column 3, line 24 - column 4, line 2 see figures 1, 2</p> <p style="text-align: center;">-----</p>	<p>8, 38</p>

INTERNATIONAL SEARCH REPORT

Information on patent family members

International Application No

PCT/US 99/02838

Patent document cited in search report	Publication date	Patent family member(s)	Publication date
US 5563906 A	08-10-1996	NONE	
US 5519692 A	21-05-1996	NONE	
US 4628517 A	09-12-1986	DE 3121146 A	05-01-1983
		AR 229991 A	31-01-1984
		AT 18839 T	15-04-1986
		AU 530445 B	14-07-1983
		AU 8419582 A	02-12-1982
		CA 1198169 A	17-12-1985
		EP 0065764 A	01-12-1982
		JP 57199356 A	07-12-1982
		ZA 8203649 A	30-03-1983