

(19) World Intellectual Property Organization
International Bureau



(43) International Publication Date
26 January 2012 (26.01.2012)

(10) International Publication Number
WO 2012/011993 A1

(51) International Patent Classification:
E21B 23/00 (2006.01)

(21) International Application Number:
PCT/US2011/033796

(22) International Filing Date:
25 April 2011 (25.04.2011)

(25) Filing Language: English

(26) Publication Language: English

(30) Priority Data:
61/366,692 22 July 2010 (22.07.2010) US

(71) Applicant (for all designated States except US):
EXXONMOBIL UPSTREAM RESEARCH COMPANY [US/US]; Corp-urc-sw359, P.o. Box 2189, Houston, TX 77252-2189 (US).

(72) Inventors; and

(75) Inventors/Applicants (for US only): **ALVAREZ, Jose, O.** [US/US]; 1317 Oneil Street, Houston, TX 77019 (US). **HECKER, Michael, T.** [US/US]; 16211 Castle-grove Court, Tomball, TX 77377 (US). **LONG, Ted, A.** [US/US]; 3806 West Wisteria Circle, Sugar Land, TX 77479 (US). **CLINGMAN, Scott, R.** [US/US]; 2139 Mc-clendon Street, Houston, TX 77030 (US).

(74) Agents: **JAMES, Rick, F.** et al.; Exxonmobil Upstream Research Company, Corp-urc-sw359, P.o. Box 2189, Houston, TX 77252-2189 (US).

(81) Designated States (unless otherwise indicated, for every kind of national protection available): AE, AG, AL, AM, AO, AT, AU, AZ, BA, BB, BG, BH, BR, BW, BY, BZ, CA, CH, CL, CN, CO, CR, CU, CZ, DE, DK, DM, DO, DZ, EC, EE, EG, ES, FI, GB, GD, GE, GH, GM, GT, HN, HR, HU, ID, IL, IN, IS, JP, KE, KG, KM, KN, KP, KR, KZ, LA, LC, LK, LR, LS, LT, LU, LY, MA, MD, ME, MG, MK, MN, MW, MX, MY, MZ, NA, NG, NI, NO, NZ, OM, PE, PG, PH, PL, PT, RO, RS, RU, SC, SD, SE, SG, SK, SL, SM, ST, SV, SY, TH, TJ, TM, TN, TR, TT, TZ, UA, UG, US, UZ, VC, VN, ZA, ZM, ZW.

(84) Designated States (unless otherwise indicated, for every kind of regional protection available): ARIPO (BW, GH, GM, KE, LR, LS, MW, MZ, NA, SD, SL, SZ, TZ, UG, ZM, ZW), Eurasian (AM, AZ, BY, KG, KZ, MD, RU, TJ, TM), European (AL, AT, BE, BG, CH, CY, CZ, DE, DK, EE, ES, FI, FR, GB, GR, HR, HU, IE, IS, IT, LT, LU, LV, MC, MK, MT, NL, NO, PL, PT, RO, RS, SE, SI, SK, SM, TR), OAPI (BF, BJ, CF, CG, CI, CM, GA, GN, GQ, GW, ML, MR, NE, SN, TD, TG).

Declarations under Rule 4.17:

- as to applicant's entitlement to apply for and be granted a patent (Rule 4.17(ii))
- as to the applicant's entitlement to claim the priority of the earlier application (Rule 4.17(iii))

Published:

- with international search report (Art. 21(3))

(54) Title: METHODS FOR STIMULATING MULTI-ZONE WELLS

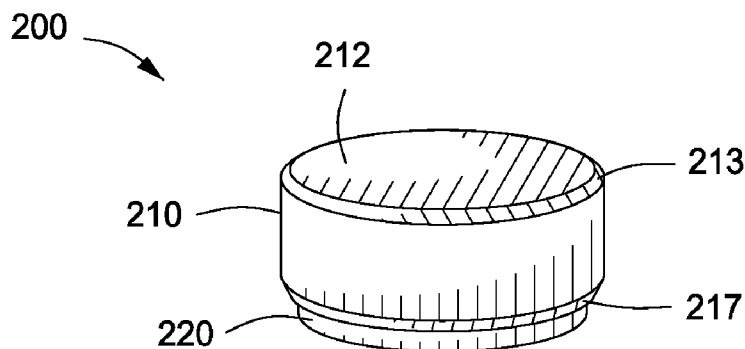

FIG. 2A

(57) Abstract: A method for stimulating a multi-zone wellbore completed with a string of production casing, including pumping a first volume of acidic fluid into the wellbore under pressure, and then injecting the first volume of acidic fluid into a first zone of interest along the production casing dropping at least one plug into the wellbore, the plug being fabricated from a material that substantially dissolves in the presence of the acidic fluid at or over a selected period of time.



WO 2012/011993 A1

METHODS FOR STIMULATING MULTI-ZONE WELLS

CROSS-REFERENCE TO RELATED APPLICATION

[0001] This application claims the priority benefit of U.S. Provisional Patent Application
5 61/366,692 filed 22 July 2010 entitled METHODS FOR STIMULATING MULTI-ZONE
WELLS, the entirety of which is incorporated by reference herein.

FIELD OF THE INVENTION

[0002] This section is intended to introduce various aspects of the art, which may be
associated with exemplary embodiments of the present disclosure. This discussion is
10 believed to assist in providing a framework to facilitate a better understanding of particular
aspects of the present disclosure. Accordingly, it should be understood that this section
should be read in this light, and not necessarily as admissions of prior art.

[0003] The present inventions relate to the completion of hydrocarbon-producing wells.
More specifically, the inventions relate to acid stimulations for multi-zone wellbores.

15

BACKGROUND

[0004] In the drilling of oil and gas wells, a wellbore is formed using a drill bit that is
urged downwardly at a lower end of a drill string. After drilling to a predetermined depth,
the drill string and bit are removed and the wellbore is lined with a string of casing. An
annular area is thus formed between the string of casing and the formation.

20 [0005] A cementing operation is typically conducted in order to fill or “squeeze” the
annular area with cement. This serves to form a cement sheath. The combination of cement
and casing strengthens the wellbore and facilitates the isolation of the formations behind the
casing.

25 [0006] It is common to place several strings of casing having progressively smaller outer
diameters into the wellbore. Thus, the process of drilling and then cementing progressively
smaller strings of casing is repeated several or even multiple times until the well has reached
total depth. The final string of casing, referred to as a production casing, is cemented into
place. In some instances, the final string of casing is a liner, that is, a string of casing that is
not tied back to the surface, but is hung from the lower end of the preceding string of casing.

[0007] As part of the completion process, the production casing is perforated at a desired level. This means that lateral holes are shot through the casing and the cement sheath surrounding the casing to allow hydrocarbon fluids to flow into the wellbore. Thereafter, the formation is stimulated either by hydraulic fracturing (injecting fluid under high pressure through the perforations in order to create flow-channels in the formation) or by acid stimulation (circulating an acidic solution through the wellbore).

[0008] As an additional step in the wellbore completion process, production equipment such as tubing, packers and pumps may be installed within the wellbore. A wellhead (or “tree”) is installed at the surface along with fluid gathering and processing equipment. Production operations may then commence.

[0009] Before beginning production, it is sometimes desirable for the drilling company to “stimulate” the formation by injecting an acid solution through the perforations. This is particularly true when the formation comprises carbonate rock. Injection of the acid stimulation fluid creates channels called “wormholes.”

[0010] In operation, the drilling company injects a concentrated formic acid or other acidic composition into the wellbore, and directs the fluid into the subsurface formation. This is known as acidizing. The acid helps to dissolve carbonate material, thereby opening up porous channels through which hydrocarbon fluids may flow into the wellbore. In addition, the acid helps to dissolve drilling mud that may have invaded the formation. Application of hydraulic fracturing and acid stimulation as described above is a routine part of petroleum industry operations.

[0011] In many wellbores, it is now common to complete a well through multiple zones of interest. Such zones may represent up to about 30 meters (about 100 feet) of gross, vertical thickness of subterranean formation. When there are multiple or layered reservoirs to be hydraulically fractured, or a very thick hydrocarbon-bearing formation, then more complex treatment techniques are required to obtain treatment of each of the target zones. In this respect, the drilling company must isolate various zones to ensure that each separate zone is not only perforated, but adequately stimulated (fractured and/or acidized). In this way the operator is sure that stimulant is being injected through each set of perforations and into each zone of interest to effectively increase the flow capacity at each desired depth.

[0012] This same issue may arise when an operator desires to stimulate a well after a period of production. In this respect, the operator may desire to perform acid stimulation in multiple pay zones. However, because the wellbore has multiple sets of perforations, it is desirable to direct the acidizing solution into each separate zone of interest while sealing off
5 lower zones of interest.

[0013] To do this, various fluid diversion techniques may be employed. Two general categories of fluid diversion have been developed to help ensure that the acid reaches the desired rock matrix – mechanical and chemical. Mechanical diversion involves the use of a physical or mechanical diverter that is placed within the wellbore. Chemical diversion, on
10 the other hand, involves the injection of a fluid or particles into the wellbore.

[0014] Referring first to chemical diverters, chemical diverters include foams, particulates, gels, and viscosified fluids. Foam commonly comprises a dispersion of gas and liquid wherein a gas is in a non-continuous phase and liquid is in a continuous phase. Where acid is used as the liquid phase, the mixture is referred to as a foamed acid. In either event, as
15 the foam mixture is pumped downhole and into the porous medium that comprises the original, more permeable formation, additional foam is generated. The foam initially builds up in the areas of high permeability until it provides enough resistance to force the acid into the new zone of interest having a lower permeability. The acid is then able to open up pores and channels in the new formation.

[0015] Particulate diverters consist of fine particles. Examples of known particulate diverters are cellophane flakes, oyster shells, crushed limestone, gilsonite, oil-soluble naphthalenes, and even chicken feed. Within the last several years, solid organic acids such as lactic acid flakes have been used. As the particles are injected, they form a low permeability filter-cake on the face of wormholes and other areas of high permeability in a
20 lower formation. This then forces acid treatment to enter upper zone(s) of interest. After the acidizing treatment is completed, the particulates hydrolyze in the presence of water and are converted into acid.

[0016] Viscous diverters are highly viscous materials, sometimes referred to as gels. Gels use either a polymer or a viscoelastic surfactant (VES) to provide the needed viscosity.
30 Polymer-based diverters crosslink to form a viscous network upon reaction with the formation. The crosslink breaks upon continued reaction and/or with an internal breaker.

VES-based diverters increase viscosity by a change in micelle structure upon reaction with the formation. As the high-viscosity material is injected into the formation, it fills existing wormholes. This allows acid to be injected into areas of lower permeability higher in the wellbore. The viscosity of the gel breaks upon exposure to hydrocarbons (on flowback) or
5 upon contact with a solvent.

[0017] Referring now to mechanical diverters, various types of mechanical diverters have been employed. These generally include ball sealers, plugs, and straddle packers. For example, U.S. Pat. No. 3,289,762 uses a ball that seats in a baffle to cause mechanical isolation. U.S. Pat. No. 5,398,763 uses a wireline to set and then to retrieve a baffle. The
10 baffle isolates a portion of a formation for the injection of fluids. U.S. Pat. No. 6,491,116 provides a fracturing plug, or “frac plug.” Frac plugs are common in the industry and rely upon a ball that is either dropped from the surface to land on a seat, or that is integral to the plug itself. Frac plugs generally require a wireline for setting. Frac plugs may also be retrieved via wireline, although in some instances frac plugs have been fabricated from
15 materials that can be drilled out. Drilling out the material adds time and expense to the stimulation operation.

[0018] Mechanical plugs are used to isolate an interval after successfully stimulating a lower zone. Although the stimulation of each zone separately can be very effective, multiple electric line runs and acid stimulations may be required to fully stimulate a long interval,
20 increasing the time and cost of the acid treatment. Further, while mechanical plugs can provide high confidence that formation treatment fluid is being diverted, there is a risk of incurring high costs due to mechanical and operational complexity of the plugs. Plugs may become stuck in the casing resulting in a lengthy and costly fishing operation. If fishing is unsuccessful, a drilling rig may be needed to be brought on-site to drill the plug out.
25 Drilling out the plug is not preferred due to the time and cost associated with mobilizing a drilling rig on location. In some situations, the well may have to be sidetracked or even abandoned. Mechanical plugs particularly have a history of reliability issues in large diameter wells. In this respect, it can be difficult to locate a plug suitable for a large borehole, and those that are available have a history of failures.

30 [0019] A need exists for an improved mechanical plug that carries the benefits of a chemical diverter, that is, it can never become permanently stuck in the wellbore. This removes the possibility of failure and subsequent fishing operations. A need further exists for

a dissolvable plug that nevertheless improves the stimulation of upper zones in a multi-zone wellbore. In this way, each zone in a multi-zone wellbore enjoys a successful acid stimulation job, that is, all zones receive the desired amount of acid, at low cost.

SUMMARY

5 [0020] A method for stimulating a multi-zone wellbore is provided. In the method, the wellbore is completed with a string of production casing. The production casing may be joints of casing cemented into the wellbore along various subsurface zones. Alternatively, the production casing may be a liner string that is either hung or expanded into place from a next higher casing string. The liner may or may not have packers. In any case, the wellbore
10 is completed through multiple zones of interest.

[0021] The method generally includes pumping a first volume of acidic fluid into the wellbore under pressure. The acidic fluid may be, for example, an acid solution containing about 15% or more, hydrochloric acid. The current methods are not limited by the nature of the acidic composition.

15 [0022] The method also includes injecting the first volume of acidic fluid so as to inject the first volume of acidic fluid into a first zone of interest along the production casing, typically a lower zone.

[0023] The method also includes dropping a plug into the wellbore. The term “dropping” is intended to mean any method for delivering or releasing a plug into a wellbore. The plug
20 has a defined geometry such that it can be transported and handled. Preferably, the plug has a cylindrical profile, although it may alternatively be conical, semi-spherical, or other shape. The plug is fabricated from a material that substantially dissolves in the presence of the acidic fluid over a selected period of time. For example, the plug may be made of carbonate material that may not substantially dissolve for about 5 minutes to about 45 minutes.
25 Optionally, a polymeric or elastomeric coating is placed around the second plug to inhibit dissolution of the plug material. For example, the coating may delay the commencement of dissolution for about 5 to 15 minutes. Also, the plug may have an elastomeric extension to facilitate the passage of the plug through wellbore restrictions.

[0024] The plug may be a relatively short, rigid plug. In this instance, the plug will land
30 on a seat above the first zone of interest. Alternatively, the plug may be a long, viscous plug

having a gelatinous composition. In this instance, the plug will rest on the bottom of the wellbore and extend across the first zone of interest to substantially seal perforations along the first zone of interest. Alternatively, the viscous plug will break up under pumping pressure and temporarily plug the perforations along the first zone of interest. In any
5 instance, the plug is set along the production casing to inhibit the flow of a second volume of acidic fluid into the first zone of interest.

[0025] The method also includes injecting a second volume of acidic fluid into the wellbore under pressure. The second volume of acidic fluid pushes the plug down the wellbore. The plug eventually sets at or above the first zone of interest. The plug thus serves
10 as a diversion mechanism to substantially prevent acidic fluids from being pumped down to the first zone of interest.

[0026] The method then includes pumping the second volume of acidic fluid into a second zone of interest along the production casing. The second zone of interest is above the first zone of interest, meaning that it has a lower measured depth. The second volume of
15 acidic fluid is diverted into the second zone of interest by the plug, and before the plug dissolves. In one aspect, the second plug actually defines two or more cylindrical plugs that are stacked one on top of the other within the production casing in order to cover perforations along the first zone of interest. Using two or more stacked plugs may also increase the plugging capability of the plug.

[0027] The method may be extended analogously to a third zone of interest. This can be done by dropping one or more plugs before a third volume of acidic fluid is injected. The one or more plugs represent a subsequent plug, and will stack one on top of the other until extending at least partially above the second zone of interest and below a third zone of
20 interest. The third volume of acidic fluid is then injected into the third zone of interest.

[0028] As an alternative, a seat may be placed along the production casing below the second or third zones of interest. The subsequent plug will land on the seat to temporarily prevent the injection of fluid into the wellbore below the third zone of interest. It is preferable that the subsequent plug be a single rigid plug that lands on a seat above the
25 second zone of interest.

[0029] In one aspect, the method also includes dropping a previous plug into the wellbore. This is done before injecting the first volume of acidic fluid into the wellbore. The
30

previous plug is also fabricated from a material that dissolves in the presence of the acidic fluid over a selected period of time. The previous plug serves to separate the first volume of acidic fluid from wellbore fluids already residing in the wellbore. The wellbore fluids are pushed back into the formation at the various zones of interest as the first volume of acidic fluid is pumped into the wellbore.

[0030] The previous plug will be pushed below the first zone of interest. In this way, the first volume of acidic fluid may enter the first zone of interest for acidic treatment.

[0031] A separate method for stimulating a multi-zone wellbore is provided herein. The wellbore has been completed with a string of production casing in a substantially vertical orientation. The method comprises pumping a first volume of acidic fluid into the wellbore. The method then includes dropping a fluid diversion plug into the wellbore. The fluid diversion plug has a defined geometry, and is fabricated from a material that dissolves in the presence of the first volume of acidic fluid over a selected period of time.

[0032] The method also includes pumping a second volume of acidic fluid into the wellbore. As the second volume is pumped downhole, the second volume pushes the fluid diversion plug down the wellbore. This causes at least a portion of the first volume of acidic fluid to travel into a first zone of interest along the production casing.

[0033] The method further includes setting the fluid diversion plug along the production casing. The fluid diversion plug is set above the first zone of interest to inhibit the flow of the second volume of acidic fluid into the first zone of interest. The method then includes injecting at least a portion of the second volume of acidic fluid into a second zone of interest along the production casing and above the diversion plug. This takes place before the fluid diversion plug substantially dissolves.

[0034] The method also includes dropping a fluid displacement plug into the wellbore. The fluid displacement plug also has a defined geometry, and is fabricated from a material that dissolves in the presence of the second volume of acidic fluid over the selected period of time. Thereafter, a third volume of acidic fluid is pumped into the wellbore. This acts to push the fluid displacement plug down the wellbore and to at least partially inject the second volume of acidic fluid into a second zone of interest above the first zone of interest. The method then includes setting the fluid displacement plug along the production casing above

the second zone of interest. This inhibits the flow of the third volume of acidic fluid into the second zone of interest.

[0035] In one aspect of the method, the fluid displacement plug comprises at least one substantially solid body. Setting the fluid displacement plug along the production casing then comprises landing the fluid displacement plug on a seat within the production casing above the second zone of interest. In another aspect, the fluid displacement plug comprises at least one elongated gelatinous plug. Setting the fluid displacement plug along the production casing then comprises landing the at least one elongated gelatinous plugs on a bottom of the wellbore.

10 [0036] The method further comprises injecting at least a portion of the third volume of acidic fluid into the third zone of interest above the second zone of interest. This is done before the fluid displacement plug substantially dissolves.

[0037] In this method, each of the volumes of acidic fluid may comprise hydrochloric acid, acetic acid, formic acid, or combinations thereof. However, the method is not limited by the specific acidic fluid composition unless expressly stated in a claim.

BRIEF DESCRIPTION OF THE DRAWINGS

[0038] So that the present inventions can be better understood, certain drawings, charts, graphs and/or flow charts are appended hereto. It is to be noted, however, that the drawings illustrate only selected embodiments of the inventions and are therefore not to be considered limiting of scope, for the inventions may admit to other equally effective embodiments and applications.

[0039] Figure 1 is a cross-sectional view of an illustrative wellbore. The wellbore has been drilled through two different formations, each formation containing hydrocarbon fluids.

[0040] Figure 2A is a perspective view of a plug of the present invention, in one embodiment. Here, the plug is a substantially solid device.

[0041] Figure 2B is side view of the plug of Figure 2A. An optional upper centralizing member is shown added to the plug, in phantom.

[0042] Figure 3A is a side view of a well site having a wellbore for receiving a reactive plug. The wellbore has been completed in at least two zones of interest, to wit, zones "T" and "U." The wellbore has production fluids therein.

[0043] Figure 3B is another side view of the well site of Figure 3A. Here, the wellbore
5 has received a first volume of acidizing fluid. In addition, a first plug has been dropped into the wellbore ahead of the first volume of acidizing fluid. The first volume of acidizing fluid is acting downward against the production fluids.

[0044] Figure 3C is another side view of the well site of Figure 3A. Here, the first volume of acidizing fluid is being injected into the zone of interest "T."

10 [0045] Figure 3D is still another side view of the well site of Figure 3A. Here, a second plug has been dropped into the wellbore. The second plug is being injected ahead of a second volume of acidizing fluid.

[0046] Figure 3E is yet another side view of the well site of Figure 3A. Here, the reactive
15 second plug has landed on a seat along the production casing. The second volume of acidizing fluid is being injected into the zone of interest "U" above the second plug.

[0047] Figure 3F is another side view of the well site of Figure 3A. Here, the second plug is dissolving in reaction to the presence of the first and second volumes of acidizing fluid.

[0048] Figure 3G is a final side view of the well site of Figure 3A. Here, the wellbore
20 has been placed back in production. Formation fluids are being produced from zones "T" and "U." The second plug has completely dissolved.

[0049] Figure 4 is a perspective view of a viscous plug as may be used in the methods of the present invention, in one embodiment. Here, the viscous plug is a cylindrical, gelatinous body.

25 [0050] Figure 5A is a side view of a portion of a wellbore. The wellbore has been completed in multiple zones of interest, including zones "A," "B," and "C." The wellbore has production fluids therein.

[0051] Figure 5B is another side view of the wellbore of Figure 5A. Here, the wellbore has received a first volume of acidizing fluid. The first volume of acidizing fluid is acting downward against production or wellbore fluids, pushing them back into the formation at the zones of interest. An optional first plug has also been dropped into the wellbore ahead of the
5 first volume of acidizing fluid to avoid mixing of the acidic fluid with the wellbore fluids.

[0052] Figure 5C is another side view of the wellbore of Figure 5A. Here, the first volume of acidizing fluid is being injected into the zone of interest "A."

[0053] Figure 5D is another side view of the wellbore of Figure 5A. Here, a second plug has been dropped into the wellbore. The illustrative plug is a viscous plug, and is being
10 injected ahead of a second volume of acidizing fluid.

[0054] Figure 5E(1) is yet another side view of the wellbore of Figure 5A. Here, the second viscous plug has set in the production casing below zone of interest "B" by breaking up into the perforations along zone of interest "A." The second volume of acidizing fluid is being injected into the zones of interest "B" and "C."

15 [0055] Figure 5E(2) is an alternate arrangement of the wellbore of Figure 5A. Here, the second plug actually comprises two or more plugs stacked from the bottom of the wellbore to temporarily cover the perforations along the zone of interest "A." The second volume of acidizing fluid is again being injected into the zone of interest "B".

20 [0056] Figure 5F is a subsequent side view of the wellbore of Figure 5E(1). Here, the second viscous plug is dissolving in reaction to the presence of the first and second volumes of acidizing fluid.

[0057] Figure 5G(1) is still another side view of the wellbore of Figure 5A. Here, a third plug has been dropped into the wellbore. The third plug is actually a stack of viscous or solid plugs. The stack of plugs is being injected ahead of a third volume of acidizing fluid.

25 [0058] Figure 5G(2) is an alternate side view of the wellbore of Figure 5A. Here, a third plug is again being injected into the wellbore. However, the illustrative third plug is a rigid plug that is dimensioned to land on a seat along an inner diameter of the wellbore.

[0059] Figure 5H is another side view of the wellbore of Figure 5A, in sequence after the step of Figure 5G(2). Here, the third plug has set in the production casing below zone of

interest "C." The third volume of acidizing fluid is being injected into the zone of interest "C."

[0060] Figure 5I is yet another side view of the wellbore of Figure 5A. Here, the third plug is dissolving in reaction to the presence of the second and third volumes of acidizing
5 fluid.

[0061] Figure 5J is a final side view of the well site of Figure 5A. Here, the wellbore has been placed back in production. Formation fluids are being produced from zones "A," "B," and "C." The first and second plugs have been completely dissolved. The third plug is shown in a state of partial dissolution, and is now being flowed back to the surface along with
10 production fluids.

[0062] Figure 6 is a flow chart showing steps for performing a method for treating a multi-zone wellbore, in one embodiment.

DETAILED DESCRIPTION

Definitions

15 [0063] As used herein, the term "hydrocarbon" refers to an organic compound that includes primarily, if not exclusively, the elements hydrogen and carbon. Hydrocarbons generally fall into two classes: aliphatic, or straight chain hydrocarbons, and cyclic, or closed ring, hydrocarbons including cyclic terpenes. Examples of hydrocarbon-containing materials include any form of natural gas, oil, coal, and bitumen that can be used as a fuel or upgraded
20 into a fuel.

[0064] As used herein, the term "hydrocarbon fluids" refers to a hydrocarbon or mixtures of hydrocarbons that are gases or liquids. For example, hydrocarbon fluids may include a hydrocarbon or mixtures of hydrocarbons that are gases or liquids at formation conditions, at processing conditions or at ambient conditions (15° C and 1 atm pressure). Hydrocarbon
25 fluids may include, for example, oil, natural gas, coalbed methane, shale oil, pyrolysis oil, pyrolysis gas, a pyrolysis product of coal, and other hydrocarbons that are in a gaseous or liquid state.

[0065] As used herein, the terms "produced fluids" and "production fluids" refer to liquids and/or gases removed from a subsurface formation, including, for example, an

organic-rich rock formation. Produced fluids may include both hydrocarbon fluids and non-hydrocarbon fluids.

[0066] As used herein, the term "fluid" refers to gases, liquids, and combinations of gases and liquids, as well as to combinations of gases and solids, combinations of liquids and
5 solids, and combinations of gases, liquids, and solids.

[0067] As used herein, the term "gas" refers to a fluid that is in its vapor phase at 1 atm and 15° C.

[0068] As used herein, the term "oil" refers to a hydrocarbon fluid containing primarily a mixture of condensable hydrocarbons.

10 [0069] As used herein, the term "subsurface" refers to geologic strata occurring below the earth's surface.

[0070] The terms "zone" or "zone of interest" refers to a portion of a formation containing hydrocarbons.

[0071] As used herein, the term "formation" refers to any definable subsurface region.
15 The formation may contain one or more hydrocarbon-containing layers, one or more non-hydrocarbon containing layers, an overburden, and/or an underburden of any geologic formation.

[0072] As used herein, the term "wellbore" refers to a hole in the subsurface made by drilling or insertion of a conduit into the subsurface. A wellbore may have a substantially
20 circular cross section, or other cross-sectional shapes. As used herein, the term "well", when referring to an opening in the formation, may be used interchangeably with the term "wellbore."

[0073] For purposes of the present patent, the term "production casing" includes a liner string or any other tubular body fixed in a wellbore along a zone of interest.

25 **Description of Selected Specific Embodiments**

[0074] The inventions are described herein in connection with certain specific embodiments. However, to the extent that the following detailed description is specific to a

particular embodiment or a particular use, such is intended to be illustrative only and is not to be construed as limiting the scope of the inventions.

[0075] **Figure 1** is a cross-sectional view of an illustrative wellbore **100**. The wellbore **100** defines a bore **105** that extends from a surface **101**, and into the earth's subsurface **110**.
5 The wellbore **100** includes a wellhead shown schematically at **124**. The wellbore **100** further includes a shut-in valve **126**. The shut-in valve **126** controls the flow of production fluids from the wellbore **100**.

[0076] The wellbore **100** has been completed by setting a series of pipes into the subsurface **110**. These pipes include a first string of casing **102**, sometimes known as surface
10 casing or a conductor. These pipes also include a final string of casing **106**, known as a production casing. The pipes also include one or more sets of intermediate casing **104**. The present inventions are not limited to the type of completion casing used. Typically, each string of casing **102**, **104**, **106** is set in place through cement **108**. In some instances, the production casing may be a liner set using a liner hanger or an expandable joint.

15 [0077] In the illustrative arrangement of **Figure 1**, the wellbore **100** is drilled through two different formations **112**, **114**. Each formation **112**, **114** contains hydrocarbon fluids that are sought to be produced through the bore **105** and to the surface **101**. In practice, the lower formation **112** is typically produced first. This is accomplished by shooting a first set of perforations **118'** through the production casing **106** and the surrounding cement **108**. After a
20 period of time, the upper formation **114** is produced. This is accomplished by shooting a second set of perforations **118''** through the production casing **106** and the surrounding cement **108**.

[0078] In one aspect, the lower formation **112** is produced through the first set of perforations **118'** for a period of time. Optionally, the second set of perforations **118''** is not
25 shot until production within the lower formation **112** begins to taper off. Either way, it is desirable to stimulate the upper formation **114** before production from the upper formation **114** commences. Alternatively, once production has taken place from each of the lower **112** and upper **114** formations over a period of time, it may be desirable to stimulate the formations **112**, **114** to increase hydrocarbon production levels.

30 [0079] To do so, the present disclosure offers an improved diversion plug, and improved methods for diverting fluids in a wellbore. **Figures 2A** and **2B** demonstrate an illustrative

diversion plug **200**, in one embodiment. **Figure 2A** shows the plug **200** in perspective view, while **Figure 2B** provides a side view. **Figures 2A** and **2B** will be discussed together.

[0080] The diverting plug **200** first comprises a body **210**. In the illustrative arrangement of **Figures 2A** and **2B**, the body **210** is shaped as a cylindrical disc. However, other plug
5 shapes may be used, such as domes (semi-spheres) and cones. Domes and cones potentially enhance the strength of the diverting plug **200** once it is seated along production casing.

[0081] The plug **200** has an upper end **212** and a bottom end **214**. In the arrangement of **Figures 2A** and **2B**, the upper end **212** tapers to a flat surface. Optionally, the upper end **212** includes a small hook (not shown) for releasably connecting to a wireline. At the same time,
10 the bottom end **214** tapers to a stepped surface **220**. The optional stepped surface **220** creates a small lower centralizing member to help stabilize the plug **200** after it is landed on the seat (shown in **Figure 3D**, discussed below).

[0082] The bottom end **214** of the plug **210** includes an optional beveled edge **217**. In one aspect, the beveled edge **217** of the plug **200** matches a beveled edge milled into an inner
15 diameter of the seat (not shown). This too helps to strengthen the plug **200** against the hydraulic pressures exerted during a wellbore stimulation operation.

[0083] Another optional feature for the plug **200** is the addition of an upper and/or lower centralizing member. An upper centralizing member is shown in phantom lines at **230** in **Figure 2B**. The upper centralizing member **230** helps keep the plug **230** straight within the
20 bore of the production casing as the plug **200** is pumped downhole. The upper centralizing member **230** also helps keep fluid from bypassing the plug **200** during pump-in, and later helps with fluid diversion when fluid is pumped into a selected zone of interest.

[0084] The upper centralizing member **230** has a diameter that closely matches that of a surrounding production casing (such as casing **330**). The upper centralizing member **230** is
25 fabricated from a compliant material, such as butadiene rubber. This helps the plug **200** pass through restrictions in the production casing.

[0085] The illustrative centralizing member **230** of **Figure 2B** includes a concave portion **235**. The concave portion **235** helps create a seal between the centralizing member **230** and the surrounding production casing during pump-in. In this respect, hydrostatic head and
30 pumping pressure cause the concave portion **235** to expand outwardly against the production

casing, preventing a bypass of fluids around the centralizing member **230** and around the plug **200**.

[0086] The upper end **212** of the plug **200** may also include a beveled edge **213**. When the optional lower centralizing member (stepped surface **220**) or upper centralizing member **230** are both not used, such an arrangement allows the plug **200** to be placed into a wellbore without regard to which end is the top end **212** and which end is the bottom end **214**. In other words, the plug **200** becomes symmetrical.

[0087] It is understood that the geometry of the plug **200** is a matter of designer's choice. For example, the operator may prefer to have a plug with a body having a diameter that is smaller than a diameter of the centralizing member **230**. As another example, the operator may prefer to have a plug with a centralizing member placed on both the upper and lower portions of the plug body **210**. This arrangement is beneficial in that as the plug **200** is being pumped into the wellbore, the upper centralizing member **230** may begin to dissolve. However, the bottom centralizing member may remain intact, preventing fluid bypass around the plug **200**.

[0088] What is important is that the diverting plug **200** be dimensioned to be launched into a wellbore as part of a well stimulation procedure. In addition, and in accordance with the present inventions, the plug **200** is fabricated from a material that will dissolve in the wellbore after a selected period of time. In this way, there is no risk of the plug **200** becoming permanently stuck in the wellbore.

[0089] To provide for this, the plug **200** is fabricated from a material that reacts with fluids. Where the plug **200** is used as part of a multi-zone acidization procedure, the plug **200** will be fabricated from a material that dissolves in the presence of acid. An example of such an acid is an acidic fluid comprised of about 15% to 50% hydrochloric acid or formic acid. Where the plug **200** is used as part of a fracturing procedure, the plug **200** is fabricated from a material that dissolves in the presence of brine. Examples of suitable material include sodium bicarbonate, calcite rock, chalk rock, or combinations thereof.

[0090] Preferably, the material that dissolves in the presence of fluid will begin to dissolve in about 1 minute to 30 minutes. More preferably, the material will begin to dissolve in about 5 minutes to 15 minutes. In addition, it is desirable that the material forming the plug **200** have a density that is greater than the fluid that is pushing it in the wellbore. In this

way, the plug **200** can more easily move downward through the production casing in response to hydrostatic pressure and pumping.

[0091] Where the plug **200** has the upper centralizing member **230**, it is desirable that the upper centralizing member **230** be fabricated from a material that will not dissolve in the presence of fluids as quickly as the body **210**. For example, the upper centralizing member **230** may be fabricated from acid reactive polymers or elastomers. Non-limiting examples include polyester, polycarbonates, polylactic acid, nylon, cellulose, starch, acrylonitrile, polyurethane, and polyacrylate.

[0092] Alternatively or in addition, an outer layer may be provided over the plug body **210** to delay the reaction with the acidic fluid and the dissolving of the plug **230** in the wellbore. Again, examples of suitable materials are polyester, polycarbonates, polylactic acid, nylon, cellulose, starch, acrylonitrile, polyurethane, and polyacrylate. Alternatively, the outer layer may be fabricated from water-soluble materials such as a water soluble hardened gel. Examples of a water-soluble hardened gel include pullulan, hypromellose, and gelatin. The dimensions, density, shape and amount of material will depend on the operational needs.

[0093] **Figures 3A through 3G** demonstrate the use of the reactive plug **200** in an illustrative wellbore. First, **Figure 3A** presents a side view of a well site **300**. The well site **300** includes a wellhead **370** and a wellbore **310** for receiving the plug **200**. The wellbore **310** is generally in accordance with wellbore **10** of **Figure 1**; however, it is shown in **Figure 3A** that the wellbore **310** is being completed in a subsurface formation **350** through at least zones of interest “**T**” and “**U**.”

[0094] The wellbore **310** is first formed with a string of surface casing **320**. The surface casing **320** has an upper end **322** in sealed connection with a lower master valve **372**. The surface casing **320** also has a lower end **324**. The surface casing **320** is secured in the formation **350** with a surrounding cement sheath **312**.

[0095] The wellbore **310** also includes a string of production casing **330**. The production casing **330** is also secured in the formation **350** with a surrounding cement sheath **314**. The production casing **330** has an upper end **332** in sealed connection with an upper master fracture valve **374**. The production casing **330** also has a lower end **334**. The production casing **330** extends through a lowest zone of interest “**T**,” and also through at least one higher

zone of interest “U” above the zone “T.” A wellbore operation will be conducted that includes acidizing each of zones “T” and “U” sequentially.

[0096] It can be seen that the production casing 330 has been perforated along each of the zones “T” and “U”. Perforations and accompanying formation fractures are shown at 352T
5 and 352U, respectively. Note that zone “U” may be already perforated, or can be perforated after zone “T” is acidized.

[0097] Zones “T” and “U” may only be a short distance apart, such as only 10 feet or only 20 feet apart. Alternatively, zones “T” and “U” may be a considerable distance apart, such as 30 feet or even 100 feet apart. A break is shown in the production casing 330 to
10 indicate that the distance may vary. In addition, the break indicates that additional zones of interest may optionally exist between zones “T” and “U.”

[0098] A wellhead 370 is positioned above the wellbore 310. The wellhead 370 includes the lower 372 and upper 374 master fracture valves. The wellhead 370 may also include blow-out preventers (not shown). In addition, trucks having tanks and pumps (not shown) are
15 typically used to inject and circulate treating fluids such as acid.

[0099] In the view of Figure 3A, the production casing 330 is filled with wellbore fluids. The wellbore fluids are indicated at 305. Where the well site 300 is undergoing completion, the wellbore fluids 305 may represent a combination of drilling mud, formation fluids, and hydraulic fluids used in connection with perforating and fracturing the zones of interest “T”
20 and “U.” Where the well site 300 has been in production and the formation 350 is now undergoing remediation, the wellbore fluids 305 represent fluids that have been produced from the zones of interest “T” and “U.” In any event, the wellbore fluids 305 will be temporarily pushed back into the formation 350 as part of an acidizing operation.

[00100] The production casing 330 has a seat 336. The seat 336 is placed along the inner
25 diameter of the production casing 330 above the lowest zone of interest “T.” The seat 336 may define a shoulder milled into the wall of the production casing 330. In this instance, the seat 336 represents a reduced inner diameter portion. Such a reduced inner diameter portion may be only a few centimeters in length, or may extend along the length of the production casing 330 to the lower end 334. Alternatively, the seat 336 may be a baffle remaining from
30 an earlier perforating operation. The present methods are not limited by the type of seat provided, so long as it provides a restriction to the downward travel of a solid plug.

[00101] **Figure 3B** is a next side view of the well site **300** of **Figure 3A**. Here, the wellbore **310** has received a first volume of acidizing fluid. The first volume of acidizing fluid is indicated at **315**. In addition, a first plug **325** has optionally been dropped into the wellbore **310** ahead of the first volume of acidizing fluid **315**. The first plug **325** is generally
5 arranged in accordance with plug **200** of **Figure 2A**. In this respect, the plug **325** may be a relatively dense or solid, cylindrical device fabricated from a material that is reactive with acid.

[00102] The first plug **325** will have an outer diameter that is smaller than the inner diameter of the seat **336**. In this way, the first plug **325** will not catch on the seat **336** while
10 the first volume of acidizing fluid **315** is being injected into the wellbore **310**; instead, the plug **325** will be pumped past the zone of interest “**T**” and to the lower end **334** of the production casing **330**.

[00103] In **Figure 3B**, the first volume of acidizing fluid **315** is acting downwardly against the wellbore fluids **305**. A combination of hydrostatic head and pumping pressure act
15 against the wellbore fluids **305**. The first plug **325** separates the first volume of acidizing fluid **315** from the wellbore fluids **305**. This preserves the integrity of the first volume of acidizing fluid **315** as a substantially pure fluid. Stated another way, the first plug **325** prevents the first volume of acidizing fluid **315** from bypassing or mixing with the wellbore fluids **305**. This is of particular concern where the wellbore **310** is deviated or, particularly,
20 where the wellbore **310** is almost horizontal. In that instance, differences in fluid density can create the potential for fluid bypass.

[00104] In **Figure 3B**, the wellbore fluids **305** are being pushed into the formation **350** ahead of the first plug **325**. Wellbore fluids **305** are entering both the zone of interest “**T**” and the zone of interest “**U**.”

25 [00105] **Figure 3C** is another side view of the well site **300** of **Figure 3A**. Here, the first volume of acidizing fluid **315** has moved down adjacent to the zone of interest “**T**.” The first volume of acidizing fluid **315** is being injected into zones “**T**” and “**U**.”

[00106] As shown in **Figure 3C**, the first plug **325** has moved to the lower end **334** of the production casing **330**. Because the first plug **325** is fabricated from a material that is
30 reactive to acid, it has become smaller. The first plug **325** will completely dissolve in a matter of minutes.

[00107] **Figure 3D** is still another side view of the well site **300** of **Figure 3A**. Here, a second volume of acidizing fluid has been injected into the wellbore **310**. The second volume of acidizing fluid is indicated at **335**. In addition, a second plug **345** has been dropped into the wellbore **310** ahead of the second volume of acidizing fluid **335**. The second plug **345** is generally arranged in accordance with plug **200** of **Figure 2**. In this respect, the plug **345** may be a relatively dense or solid, cylindrical device fabricated from a material that is reactive with acid.

[00108] The second plug **345** will have an outer diameter that is slightly larger than the inner diameter of the seat **336**. In this way, the second plug **345** will catch on the seat **336** while the second volume of acidizing fluid **335** is being injected into the wellbore **310**. This will allow the second plug **345** to serve as a diversion agent.

[00109] In **Figure 3D**, the second volume of acidizing fluid **335** is acting downward against the first volume of acidizing fluid **315**. A combination of hydraulic head and pumping pressure act against the first volume of acidizing fluid **315**. The second plug **345** separates the second volume of acidizing fluid **335** from the first volume of acidizing fluid **315**, although there is no concern here about preserving the integrity of the first volume of acidizing fluid **315** as the first **315** and second **335** volumes are typically of the same fluid composition.

[00110] In **Figure 3D**, the first volume of acidizing fluid **315** is pushed into the formation **350** ahead of the second plug **345**. The first volume of acidizing fluid **315** enters both the zone of interest “**T**” and the zone of interest “**U**,” but primarily the lower zone “**T**.”

[00111] **Figure 3E** is yet another side view of the well site **300** of **Figure 3A**. Here, the second reactive plug **345** has landed on the seat **336** along the production casing **330**. This prevents the further injection of fluid into the lowest zone of interest “**T**.” The second volume of acidizing fluid **335** is now being effectively injected into the higher of the two zones of interest, to wit, zone of interest “**U**.”

[00112] It is noted that in the step of **Figure 3E**, only one “second” reactive plug **345** is shown. However, the operator may choose to drop more than one “second” plug **345**. For example, if the operator is concerned that the plug **345** may dissolve too quickly and not allow for a complete treatment into zone of interest “**U**,” then the operator may choose to drop two, three or even more plugs. Alternatively, the operator may choose to stack a larger

number of plugs, for example, 25 to 50 plugs, to temporarily cover a set of intermediate perforations so as to treat a higher zone of interest.

[00113] **Figure 3F** is another side view of the well site **300** of **Figure 3A**. Here, the second plug **345** is dissolving in reaction to the presence of the first **315** and second **335** volumes of acidizing fluid. In response to hydrostatic pressure and pumping pressure applied to the second volume of acidizing fluid **335**, the second plug **345** has become “unseated” from the seat **336**. Once the seal is broken between the seat **336** and the second plug **345**, acidic fluids from the second volume **335** will quickly begin invading all zones of interest.

[00114] It is noted that the second plug **345** is fabricated so that it’s dissolution will not initiate until time has passed to permit an acceptable volume of acidizing fluid (volume **335**) to be injected into the corresponding zone of interest. In one aspect, the second plug **345** is fabricated so that significant dissolution will not take place until the desired amount of acidic fluid enters Zone “U.” In another aspect, the plug **345** is fabricated so that significant dissolution will not take place for between 5 minutes and 15 minutes.

[00115] **Figure 3G** is a final side view of the well site **300** of **Figure 3A**. Here, the wellbore **310** has been completed and placed in production. Formation fluids **375** are being produced from both zones “T” and “U.” The first **325** and second **345** plugs have long been dissolved. The second volume of acidizing fluid **335** is being returned to the surface **101** with the formation fluids **375**.

[00116] **Figures 3A** through **3G** demonstrate the use of a substantially solid diversion plug as may be used to acidize or otherwise stimulate two separate zones of interest (zones “T” and “U”) within an illustrative wellbore **310**. While only two zones of interest are shown, it is understood that the stimulation process illustrated in **Figures 3A** through **3G** may be used to treat multiple zones. It is also understood that where the wellbore **310** is substantially vertical, the first plug **325** is optional. All that is required is that plugs used to divert treatment fluids from a lowest zone of interest be dimensioned to land on a seat provided along an inner diameter of the production casing **330**.

[00117] An alternate process is disclosed herein that does not require the use of substantially solid plugs and seats. **Figure 4** provides a perspective view of a viscous plug **400** that may be used in lieu of the dense plug **200** of **Figures 2A** and **2B**. The viscous plug **400** defines an elongated cylindrical body **410**. The body **410** may be, for example, about

two feet (0.6 meters) up to 30 feet (9.1 meters) or even up to 50 feet (15.2 meters) in length. Preferably, the cylindrical body **410** is dimensioned to be transported in the bed of a pick-up truck or in a delivery truck.

[00118] The cylindrical body **410** defines a gelatinous object having a high viscosity at ambient conditions (15° C and 1 atm pressure). For example, the viscosity may be greater than about 50 centipoise, and more preferably, greater than about 75 centipoise. The plug **400** has a diameter that approximates the inner diameter of the production casing (such as production casing **106**). For transportation purposes, the plug **400** may be wrapped in thick, water-proof paper or plastic to facilitate handling. This outer covering would be removed before the plug **400** is dropped into the casing string. Alternatively, the plug **400** may include an encapsulating hardened shell to facilitate handling. In any instance, the plug **400** represents a defined geometry, as opposed to an amorphous fluid, a volume of rock salt, or a foam.

[00119] As with the plug **200**, the plug **400** is fabricated from a material that will dissolve in the presence of fluids. Where the plug **400** is used as part of a multi-zone acidization procedure, the plug **400** will be fabricated from a material that dissolves in the presence of acid. An example of such an acid is an acidic fluid comprised of about 15% to 50% hydrochloric acid or formic acid. Where the plug **400** is used as part of a multi-zone fracturing procedure, the plug **400** is fabricated from a material that dissolves in the presence of brine. Examples of suitable material include sodium bicarbonate, calcite rock, chalk rock, or combinations thereof.

[00120] Preferably, the material that dissolves in the presence of fluid will begin to dissolve in about 1 minute to 30 minutes. More preferably, the material will begin to dissolve in about 5 minutes to 15 minutes. In addition, it is desirable that the material forming the plug **400** have a density that is greater than the fluid that is pushing it in the wellbore. In this way, the plug **400** can move downward through the production casing in response to both gravitational pull and pumping.

[00121] The viscous plug **400** has an outer diameter dimensioned to closely fit into the inner diameter of a string of production casing. In one aspect, multiple plugs **400** having a length of about 5 feet (1.5 meters) are dropped into a wellbore in a stack. Using shorter length plugs allows the plugs **400** to be easily delivered to a wellsite and carried by hand.

[00122] In operation, one or more plugs **400** are dropped into a wellbore, and then pumped downhole. When the plug **400** reaches the lowest set of perforations, the plug **400** will be dissolving while choking the flow into the surrounding zone of interest. This, in turn, has the effect of substantially diverting injected fluid into an upper unstimulated zone until
5 the acidic fluid significantly dissolves the plug **400**.

[00123] **Figures 5A through 5J** demonstrate a process for treating multiple zones of interest in a wellbore sequentially using a reactive, viscous plug **400**.

[00124] First, **Figure 5A** is a side view of a lower portion of a wellbore **500**. The wellbore **500** has been completed in multiple zones of interest, including zones "A," "B," and
10 "C." The zones of interest "A," "B," and "C" reside within a subsurface **510** containing hydrocarbon fluids. The wellbore **500** has been perforated at each of zones "A," "B," and "C." Perforations are seen at **526A**, **526B**, and **526C**, corresponding to zones "A," "B," and "C."

[00125] The wellbore **500** includes a string of production casing (or, alternatively, a
15 liner string) **520**. The production casing **520** has been cemented into a formation **510** to isolate the zones of interest "A," "B," and "C" as well as other strata along the formation **510**. A cement sheath is seen at **524**.

[00126] The wellbore **500** has a bottom end at **512**. The production string **520** also has a lower end **522** that extends to the bottom end **512** of the wellbore **500**.

20 [00127] The wellbore **500** is part of a well that is being formed or has been formed for the production of hydrocarbons. In order to stimulate production from the formation **510**, it is desirable to circulate acid adjacent to and within each of the zones of interest "A," "B," and "C." This may be done either during completion of the well, or later as part of a remediation operation.

25 [00128] In the view of **Figure 5A**, the production casing **520** is filled with wellbore fluids. The wellbore fluids are indicated at **505**. Where the wellbore **500** is undergoing completion, the wellbore fluids **505** may represent a combination of drilling mud, formation fluids, and completion fluids used in connection with perforating the zones of interest "A," "B," and "C." Where the wellbore **500** has been under production and the formation **510** is
30 now undergoing remediation, the wellbore fluids **505** represent fluids that have been

produced from the zones of interest “A,” “B,” and “C.” In any event, the wellbore fluids **505** will be temporarily pushed into the formation **510** as part of the acidizing operation.

[00129] **Figure 5B** is another side view of the wellbore **500** of **Figure 5A**. Here, the wellbore **500** has received a first volume of acidizing fluid **515**. In addition, a first plug **525** has optionally been injected into the wellbore **500** ahead of the first volume of acidizing fluid **515**. In this arrangement, the first plug **525** comprises a pumpable viscous gel. The gelatinous plug **525** defines a cylindrical body, and helps to isolate the first volume of acidizing fluid **515** from the wellbore fluids **505**. This preserves the integrity of the first volume of acidic fluid **515**, and also prevents the first volume of acidizing fluid **515** from bypassing the wellbore fluids **505**. This may be of particular importance where the wellbore **500** is deviated.

[00130] It is preferred that the first plug **525** have a short length, such as less than about 5 feet (1.5 meters). In this way, the first plug **525** can substantially clear the perforations **526A** in zone “A.” This, in turn, allows the first volume of acidizing fluid **515** to penetrate the formation **510** above the bottom end **512** of the wellbore **500** without being blocked by the viscous plug **525**.

[00131] It is also preferred that the viscous plug **525** be coated with a polymeric or elastomeric material that delays the dissolution of the material making up the first plug **525**. For example, the coating may inhibit dissolution for about 5 to 15 minutes. This will help prevent the viscous plug **525** from significantly dissolving before reaching the bottom **512** of the wellbore **500**.

[00132] In **Figure 5B**, the first volume of acidizing fluid **515** is acting downwardly against the wellbore fluids **505**. A combination of hydrostatic pressure and pumping pressure act against the wellbore fluids **505**. The wellbore fluids **505** are being pushed into the formation **510** at the zones of interest “A,” “B,” and “C.”

[00133] **Figure 5C** is another side view of the wellbore **500** of **Figure 5A**. Here, the first volume of acidizing fluid **515** has reached the lowest zone of interest “A.” The first volume of acidizing fluid **515** is now being injected into zones “A,” “B,” and “C.”

[00134] As shown in **Figure 5C**, the first plug **525** has been pumped below the zone of interest “A.” The first plug **525** is now at the bottom end **512** of the wellbore **500**. Because

the first plug **525** is fabricated from a material that is reactive to acid, it is beginning to dissolve. The first plug **525** will completely dissolve in a matter of minutes.

[00135] **Figure 5D** is another side view of the wellbore of **Figure 5A**. Here, a second volume of acidizing fluid has been injected into the wellbore **500**. The second volume of acidizing fluid is indicated at **535**. In addition, a second plug **545** has been dropped into the wellbore **500** ahead of the second volume of acidizing fluid **535**. The second plug **545** also comprises a pumpable viscous gel that is reactive with acid. The second plug **545** defines a cylindrical body that may be handled at the surface and manually dropped into the wellbore **510**. The viscous second plug **545** will significantly dissolve within the wellbore **500** along zone of interest "A." In this respect, the plug **545** will temporarily block the perforations **526A** for a period of time, allowing the second plug **545** to serve as a diversion agent.

[00136] The second plug **545** is generally arranged in accordance with plug **400**. The second plug **545** has a length designed to cover all of the perforations **526A** along zone "A." The second plug **545** may be a single elongated plug or may be two or more plugs stacked and dropped together.

[00137] To ensure that the viscous plug **545** does not begin to dissolve along any of the upper zones of interest, e.g., zone "B" and zone "C," it is again preferred that the viscous plug **545** be coated with a polymeric or elastomeric material that delays the dissolution of the material making up the second plug **545**. This will help prevent the viscous plug **545** from dissolving before reaching the perforations **526C**.

[00138] In **Figure 5D**, the second volume of acidizing fluid **535** is acting downward against the first volume of acidizing fluid **515**. A combination of hydrostatic pressure and pumping pressure act against the first volume of acidizing fluid **515**. The second plug **545** separates the second volume of acidizing fluid **535** from the first volume of acidizing fluid **515**. This preserves the integrity of the first volume of acidizing fluid **515** as a substantially pure fluid. Of course, it is likely that the composition of the first **515** and second **535** volumes of acidizing fluid will have the same composition, so fluid mixing or bypassing may not be of concern.

[00139] In **Figure 5D**, the first volume of acidizing fluid **515** is pushed into the formation **550** ahead of the second plug **545**. The first volume of acidizing fluid **515** enters

both the zone of interest “A” and the zone of interest “B,” but primarily the zone of interest “A.”

[00140] Figure 5E(1) is yet another side view of the wellbore 500 of Figure 5A. Here, the second reactive plug 545 has set in the production casing 520 below zone of interest “B.” More specifically, the viscous plug 545 has dissolved, and has temporarily plugged or clogged the perforations 526A along zone of interest “A.” This prevents the further injection of fluid into the lowest zone of interest “A” and provides a diversion mechanism for the second volume of acidizing fluid 535. The second volume of acidizing fluid 535 is now being effectively injected into zones “C” and “B.”

10 [00141] It is again noted that the second plug 545 will have a length sufficient to reach each of the perforations 526A in zone “A.” For example, the second plug 545 may be about 20 feet (6.1 meters) to 30 feet (9.1 meters), or even up to 50 feet (15.2 meters), in length. As an alternative, the operator may choose to drop more than one viscous plug to serve as the second plug 545. This means that two, three, or more cylindrical plugs may be dropped sequentially to ultimately seal the perforations 526A along zone of interest “A.” Moreover, multiple “second” plugs 545 may be dropped into the production casing 520 with the idea that they will land at the bottom 512 of the wellbore 500, and then stack.

[00142] Figure 5E(2) provides another side view of the wellbore 500 of Figure 5A. Here, the second reactive plug 545 comprises a plurality of plugs stacked from the bottom 20 512 of the wellbore 500 in order to temporarily cover the perforations 526A along the zone of interest “A.” Again, these are viscous plugs that will quickly dissolve in the presence of acid. The material making up the second plugs 545 will later be circulated back to the surface with the acidic fluids.

[00143] Whether using the step of Figure 5E(1) or the step of Figure 5E(2), the operator may be able to tell when the perforations 526A along zone “A” are plugged. In this respect, the operator may see a steeper decrease in pumping pressure while the second volume of acidizing fluid is being pumped. This steeper decrease will occur as the second viscous plug(s) 545 dissolves and the perforations 526A along zone “A” are opened up.

[00144] Figure 5F is a subsequent side view of the wellbore 500 of Figure 5E(1). Here, the second viscous plug 545 is dissolving in reaction to the presence of the first 515 and second 535 volumes of acidizing fluid. However, the second plug 545 is fabricated so that it

will not significantly dissolve until time has passed to permit an acceptable volume of acidizing fluid (volume **535**) to be injected into the zones of interest above, e.g., zone “**B**.” In one aspect, the second plug **545** is fabricated so that dissolution will not begin to take place for between 10 minutes and 40 minutes from injection into the wellbore **500**.

5 [00145] Figure **5G(1)** is still another side view of the wellbore of Figure **5A**. Here, a third volume of acidizing fluid has been injected into the wellbore **510**. The third volume of acidizing fluid is indicated at **555**. In addition, a third plug **565'** has been dropped into the wellbore **500** ahead of the third volume of acidizing fluid **555**. The third plug **565'** also comprises a pumpable viscous gel that is reactive with acid. The third plug **565'** may be a
10 very long gelatinous object, such as about 30 feet (9.1 meters) to 60 feet (18.3 meters) in length. Alternatively and more preferably, and as shown in Figure **5G(1)**, the third plug **565'** may actually comprise a series of shorter plugs that together create a long plugging body. For example, the long plugging body may be up to 100 feet (30.5 meters) or even 200 feet (61.0 meters) in length.

15 [00146] The plug **565'** is designed to temporarily cover and seal the perforations **526A** at zone of interest “**A**.” In addition, the plug **565'** is dimensioned to temporarily cover and seal the perforations **526B** at zone of interest “**B**.” In this way, the third viscous plug **565'** serves as a diverting mechanism to divert fluids into the upper zone of interest, to wit, zone “**C**.”

20 [00147] In Figure **5G(1)**, the third volume of acidizing fluid **555** is acting downward against the third plug (s) **565'**. A combination of hydrostatic pressure and pumping pressure act against the second volume of acidizing fluid **535**. The third plug **565'** separates the third volume of acidizing fluid **555** from the second volume of acidizing fluid **535**. This preserves the integrity of the second volume of acidizing fluid **535** as a substantially pure fluid. Of
25 course, it is likely that the composition of the second **535** and third **555** volumes of acidizing fluid will have the same composition, so fluid mixing or bypassing may not be of concern.

[00148] In Figure **5G(1)**, the second volume of acidizing fluid **535** is pushed into the formation **510** ahead of the third plug **565**. The second volume of acidizing fluid **535** enters both the zone of interest “**A**” and the zone of interest “**B**.”

30 [00149] Because of the length of plugging material needed to cover the perforations **526A** and **526B** when a gelatinous plug **565'** is used, the operator may choose to instead use a

rigid plug, such as the plug **200** of **Figure 2A**. In this instance, the operator may land the rigid plug on a seat without worrying about temporarily sealing multiple zones below zone of interest “C.” The rigid plug may be about 4 inches (10.16 cm) to 5 feet (1.5 meters) in length.

5 [00150] **Figure 5G(2)** provides an alternate side view of the wellbore **500** of **Figure 5A**. Here, a third volume of acidizing fluid has once again been injected into the wellbore **510**, indicated at **555**. In addition, a third plug **565**” has been dropped into the wellbore **510** ahead of the third volume of acidizing fluid **555**. In this instance the plug **565**” is a rigid plug in accordance with plug **200** of **Figure 2A**.

10 [00151] As discussed above in connection with **Figure 3A**, the production casing **520** has a seat **528** provided along an inner diameter. The seat **528** is placed above the zone of interest “B.” The seat **528** is dimensioned to “catch” the plug **565**” as it is pumped downhole. In this way, the third plug **565**” acts as a diversion mechanism to direct the third volume of acidizing fluid **555** through the perforations **526C** along the uppermost zone of
15 interest “C.”

[00152] It is understood the rigid plug **565**” may also have a substantially elongated profile just as the gelatinous plug **565**’ of **Figure 5G(1)**. In this instance, the seat **528** could optionally be removed, and a plurality of rigid plugs **565**” then stacked one on top of the other from the bottom of the wellbore. This would allow the perforations **526A**, **526B** in
20 Zones “A” and “B” to be covered, as in the arrangement of **Figure 5G(1)**. Alternatively, the seat **528** could be placed above the zone of interest “A,” and then one or more rigid plugs **565**” stacked across the perforations **526B** of the zone of interest “B.”

[00153] **Figure 5H** is another side view of the wellbore **500** of **Figure 5A**. The step show in **Figure 5H** is in sequence after **Figure 5G(2)**. This means that a rigid plug **565**” is
25 being used to seal off the uppermost zone of interest “C.” Here, the third plug **565**” has set in the production casing **520** below zone of interest “C.” More specifically, the rigid plug **565**” has landed on the seat **528** above the perforations **528B**.

[00154] The seat **528** prevents the further injection of fluids into the intermediate zone of interest “B.” The third volume of acidizing fluid **555** is now being effectively diverted and
30 injected into the zone of interest “C.”

[00155] It is noted that the operator may choose to drop a viscous plug **565'** as in **Figure 5G(1)** on top of the rigid plug **565''**. This may provide a tighter seal for the injection of fluids above the seat **528**.

[00156] Regardless of the plug arrangement in **Figure 5H**, the third plug **565''** (and optionally plug **565'**) may be fabricated so that it's dissolution is delayed until time has passed to permit an acceptable volume of acidizing fluid (third volume **555**) to be injected into the corresponding zone of interest (zone "C"). In one aspect, the third plug **565''** is fabricated with an outer layer of polymer so that dissolution of the third plug **565''** will be inhibited or delayed by about an additional five minutes to one hour.

10 [00157] **Figure 5I** is yet another side view of the wellbore **500** of **Figure 5A**. Here, the third plug **565''** is dissolving in reaction to the presence of the second **535** and third **555** volumes of acidizing fluid. The third plug **565''** soon will no longer be seated on the seat **528** and the seal will be broken. This will be sensed at the surface as the pressure reading on pump gauge will begin to decline.

15 [00158] **Figure 5J** is a final side view of the wellbore **500** of **Figure 5A**. Here, the wellbore **500** has been placed in production. Formation fluids **575** are being produced from zones "A," "B," and "C." Formation fluids **575** are flowing towards the surface. The first **525** and second **545** plugs have long since dissolved. The third plug **565''** is in a state of partial dissolution and is now being flowed back to the surface with the formation fluids **575**.

20 [00159] **Figure 6** is a flow chart showing steps for performing a method **600** for treating a multi-zone wellbore, in one embodiment. In accordance with the method **600**, the wellbore is completed along multiple zones of interest. A string of production casing (or liner) has been run into the wellbore, and the production casing has been cemented into place.

[00160] The method **600** generally includes dropping a first plug into the wellbore. This is shown at Box **610**. The first plug is fabricated from a material that dissolves in the presence of acidic fluid over a selected period of time. The first plug serves to separate a first volume of acidic fluid from wellbore fluids already residing in the wellbore.

[00161] The method **600** also includes pumping a first volume of acidic fluid into the wellbore under pressure. This step is provided at Box **620**. The acidic fluid may be, for example, an acid solution containing about 15% to 50%, or more, hydrochloric acid, acetic

30

acid, or formic acid. As the first volume of acidic acid is pumped into the wellbore, it pushes the first plug down the wellbore. Injecting also pushes existing wellbore fluids back into the formation at the various zones of interest.

[00162] The method 600 also includes injecting the first volume of acidic fluid into a first zone of interest along the production casing. This is provided at Box 630. As pumping from the step of Box 620 continues, the first plug will be pushed below the first zone of interest. Pumping continues until the first volume of acidic fluid is injected into the first zone of interest along the production casing.

[00163] The method 600 also includes dropping a second plug into the wellbore. This is seen at Box 640. The second plug is also fabricated from a material that substantially dissolves in the presence of the acidic fluid over a selected period of time. For example, the plug may not substantially dissolve for about 10 minutes to about 45 minutes. Optionally, a polymeric or elastomeric coating is placed around the second plug to inhibit dissolution of the plug material. For example, the coating may inhibit the dissolution process for about 5 to 15 minutes. The dissolution time of the second plug may be “tuned” by increasing the thickness of the coating. For example, a 1 mm coating of elastomeric material may equate to 5 minutes of additional dissolution time. Of course, various factors will affect dissolution time, including the concentration of the acid and the composition of the elastomeric material.

[00164] The second plug may be a relatively short, rigid plug. In this instance, the plug will land on a seat above the first zone of interest. Alternatively, the second plug may be a longer, viscous plug having a gelatinous composition. In this instance, the plug will rest on the bottom of the wellbore and extend across the first zone of interest to substantially seal perforations along the first zone of interest. Alternatively, the viscous plug will break up under pumping pressure and temporarily plug the perforations along the first zone of interest. In any event, the second plug has a defined geometry, as opposed to merely being a volume of foam or rock salt.

[00165] The method 600 also includes pumping a second volume of acidic fluid into the wellbore under pressure. This is indicated at Box 650. The second volume of acidic fluid pushes the second plug down the wellbore. The plug eventually sets at or above the first zone of interest. This is provided at Box 660. The second plug thus serves as a diversion

mechanism to prevent acidic fluids from being pumped down to the first zone of interest. Stated another way, the second plug serves as a fluid diversion plug.

[00166] The method then includes injecting the second volume of acidic fluid into a second zone of interest along the production casing. This is seen at Box 670. The second
5 zone of interest is above the first zone of interest. The second volume of acidic fluid is diverted into the second zone of interest by the plug before the plug dissolves. In one aspect, the second plug actually defines two or more plugs that are stacked one on top of the other within the production casing in order to extend the plug's length. Using two or more stacked plugs may also increase the plugging capability of the second plug.

10 [00167] The above steps may be repeated for a third zone of interest. This is indicated at Box 680. The third zone will be above the second zone of interest. A third plug will be deployed in the wellbore that is also reactive with acidic fluid. It is preferable that the third plug be a rigid plug that lands on a seat above the second zone of interest. As the third plug is advanced into the wellbore, it pushes at least a portion of the second fluid, which is
15 preferably an acidic fluid, into the second zone of interest. Thus, the third plug may be referred to as a fluid displacement plug.

[00168] In the method 600, use of the first plug is optional. In this respect, the first volume of acidic fluid may be injected into the first zone of interest without use of a first plug separating the first volume of acidic fluid from wellbore fluids already in place. However,
20 the use of the first plug is preferred in order to prevent fluid bypass.

[00169] As can be seen, the present inventions allow for the use of a quasi-mechanical plug that carries the benefits of a chemical diverter. In this respect, in at least some embodiments a wireline is not needed to set the plug, and the plug can never become permanently stuck in the wellbore. This removes the possibility of failure and subsequent
25 fishing operations. At the same time, the quasi-mechanical plug improves the stimulation of upper zones in a multi-zone wellbore. In this way, each zone in a multi-zone wellbore enjoys a successful acid stimulation job, that is, all zones receive the desired amount of acid, at low cost with limited risk of mechanical failure. Further, the procedure reduces cost by allowing continuous pumping of the acid treatment.

30 [00170] While it will be apparent that the inventions herein described are well calculated to achieve the benefits and advantages set forth above, it will be appreciated that

the inventions are susceptible to modification, variation and change without departing from the spirit thereof.

Claims

What is claimed is:

1. A method for stimulating a multi-zone wellbore, the multi-zone wellbore being completed with a string of production casing, and the method comprising:
 - 5 pumping a first volume of acidic fluid into the wellbore;
injecting the first volume of acidic fluid into a first zone of interest along the production casing;
dropping a plug into the wellbore, the plug having a defined geometry and being fabricated from a material that dissolves in the presence of the acidic fluid at or over a
10 selected period of time;
pumping a second volume of acidic fluid into the wellbore;
setting the plug along the production casing at least partially above the first zone of interest to inhibit the flow of the second volume of acidic fluid into the first zone of interest;
and
15 injecting the second volume of acidic fluid into a second zone of interest along the production casing and above the first zone of interest.
2. The method of claim 1, wherein each of the volumes of acidic fluid comprises hydrochloric acid, acetic acid, formic acid, or combinations thereof.
20
3. The method of claim 1, wherein the material that dissolves in the presence of the acidic fluid comprises a carbonate material or an elastomeric material.
4. The method of claim 1, wherein the material that dissolves in the presence of the
25 acidic fluid comprises carbonate, sodium bicarbonate, calcite rock, chalk rock, or combinations thereof.
5. The method of claim 1, wherein the material that dissolves in the presence of the acidic fluid also dissolves in the presence of brine.
30
6. The method of claim 1, wherein the material that dissolves in the presence of the acidic fluid is designed so as not to substantially dissolve until the second volume of acidic fluid has been injected into the second zone of interest.

7. The method of claim 6, wherein the material that dissolves in the presence of the acidic fluid does not significantly dissolve for about 5 minutes to 60 minutes after being exposed to the acidic fluid within the wellbore
- 5 8. The method of claim 6, wherein the plug is at least partially covered by a material that inhibits the reaction of the material that dissolves in the presence of the acidic fluid, thereby creating a delay in dissolution that is at least 5 minutes.
9. The method of claim 1, wherein the plug further comprises an elastomeric
10 centralizing member for centralizing the plug in the production casing during pump-in, the elastomeric material also being fabricated from a material that dissolves in the presence of the acidic fluid.
10. The method of claim 1, wherein:
15 the plug comprises a substantially solid body having an outer diameter dimensioned to be received within the wellbore; and
setting the plug in the wellbore above the first zone of interest comprises landing the plug on a seat along an inner diameter of the production casing at or above the first zone of interest.
- 20 11. The method of claim 10, wherein the seat comprises a reduced inner diameter portion milled into the production casing.
12. The method of claim 10, wherein the plug comprises a cylindrical body, a conical
25 body, or a semi-spherical body.
13. The method of claim 12, wherein the plug is about 10.1 cm to 1.5 meters in length.
14. The method of claim 10, wherein the plug defines at least two separate plugs
30 deployed in the wellbore together so as to increase the length of the plug over the seat.
15. The method of claim 1, wherein:
the plug comprises at least two substantially solid bodies, each having an outer diameter dimensioned to be received within the wellbore;

the plug is fabricated from a material that dissolves in the presence of the acidic fluid;
and

setting the plug in the wellbore above the first zone of interest comprises stacking the
at least two substantially solid bodies from the bottom of the wellbore to substantially cover
5 perforations located along the first zone of interest.

16. The method of claim 1, wherein the wellbore is completed to have either (i) a
substantially vertical lower portion, or (ii) a lower portion that is deviated no more than 30
degrees from vertical.

10

17. The method of claim 16, wherein:

the plug comprises a viscous material forming a gelatinous cylindrical body having an
outer diameter dimensioned to be received within the wellbore; and

15 setting the plug in the wellbore comprises (i) pumping the plug to perforations located
along the first zone of interest so that the gelatinous plug temporarily chokes the flow of the
second volume of acidic fluid into the perforations, thereby diverting the second volume of
acidic fluid into the second zone of interest.

18. The method of claim 17, wherein the plug is about 0.61 meters to 10.0 meters in
20 length.

19. The method of claim 18, wherein the plug defines at least two separate gelatinous
plugs deployed in the wellbore together.

25 20. The method of claim 19, wherein the at least two plugs are stacked from a bottom of
the wellbore.

21. The method of claim 1, wherein dropping the plug into the wellbore comprises
manually placing the plug into the wellhead, and then pumping the plug down the production
30 casing.

22. The method of claim 1, wherein dropping the plug into the wellbore comprises
lowering the plug partially into the wellbore on a wireline, and releasing the plug from the
wireline.

23. The method of claim 1, wherein the step of pumping the second volume of acidic fluid into the wellbore commences before the plug is dropped into the wellbore in order to increase pressure within the production casing.

5 24. The method of claim 1, further comprising:

dropping a previous plug into the wellbore before injecting the first volume of acidic fluid into the wellbore, the previous plug also having a defined geometry, and being fabricated from a material that dissolves in the presence of the acidic fluid over a selected period of time; and

10 pumping the previous plug into the production casing below the first zone of interest substantially ahead of the first volume of acidic fluid;

25. The method of claim 1, further comprising:

15 dropping a subsequent plug into the wellbore, the subsequent plug also having a defined geometry, and being fabricated from a material that dissolves in the presence of the acidic fluid at or over a selected period of time;

pumping a third volume of acidic fluid into the wellbore under pressure;

setting the subsequent plug along the production casing at least partially above the second zone of interest; and

20 injecting the third volume of acidic fluid into a third zone of interest along the production casing and above the second zone of interest.

26. A method for stimulating a multi-zone wellbore, the wellbore being completed with a string of production casing in a substantially vertical orientation, and the method comprising:

25 pumping a first volume of acidic fluid into the wellbore;

dropping a fluid diversion plug into the wellbore, the fluid diversion plug having a defined geometry, and being fabricated from a material that dissolves in the presence of the first volume of acidic fluid over a selected period of time;

30 pumping a second volume of acidic fluid into the wellbore in order to push the fluid diversion plug down the wellbore and to cause at least a portion of the first volume of acidic fluid to travel into a first zone of interest along the production casing;

setting the fluid diversion plug along the production casing above the first zone of interest to inhibit the flow of the second volume of acidic fluid into the first zone of interest;

injecting at least a portion of the second volume of acidic fluid into a second zone of interest along the production casing and above the fluid diversion plug before the fluid diversion plug substantially dissolves;

dropping a fluid displacement plug into the wellbore, the fluid displacement plug also
5 having a defined geometry, and being fabricated from a material that dissolves in the presence of the second volume of acidic fluid over the selected period of time; and

pumping a third volume of fluid into the wellbore in order to push the fluid displacement plug down the wellbore and to at least partially inject the second volume of acidic fluid into a second zone of interest above the first zone of interest.

10

27. The method of claim 26, wherein:

the third volume of fluid is a third volume of acidic fluid; and

the method further comprises:

15 setting the fluid displacement plug along the production casing above the second zone of interest to inhibit the flow of the third volume of acidic fluid into the second zone of interest; and

injecting at least a portion of the third volume of acidic fluid into the third zone of interest above the second zone of interest before the fluid displacement plug substantially dissolves.

20

28. The method of claim 27, wherein each of the volumes of acidic fluid comprises hydrochloric acid, acetic acid, formic acid, or combinations thereof.

29. The method of claim 27, wherein:

25 the fluid displacement plug comprises at least one substantially solid body; and

setting the fluid displacement plug along the production casing comprises landing the fluid displacement plug on a seat within the production casing above the second zone of interest.

30 30. The method of claim 27, wherein:

the fluid displacement plug comprises at least one elongated gelatinous plug; and

setting the fluid displacement plug along the production casing comprises landing the at least one elongated gelatinous plug on a bottom of the wellbore.

1/22

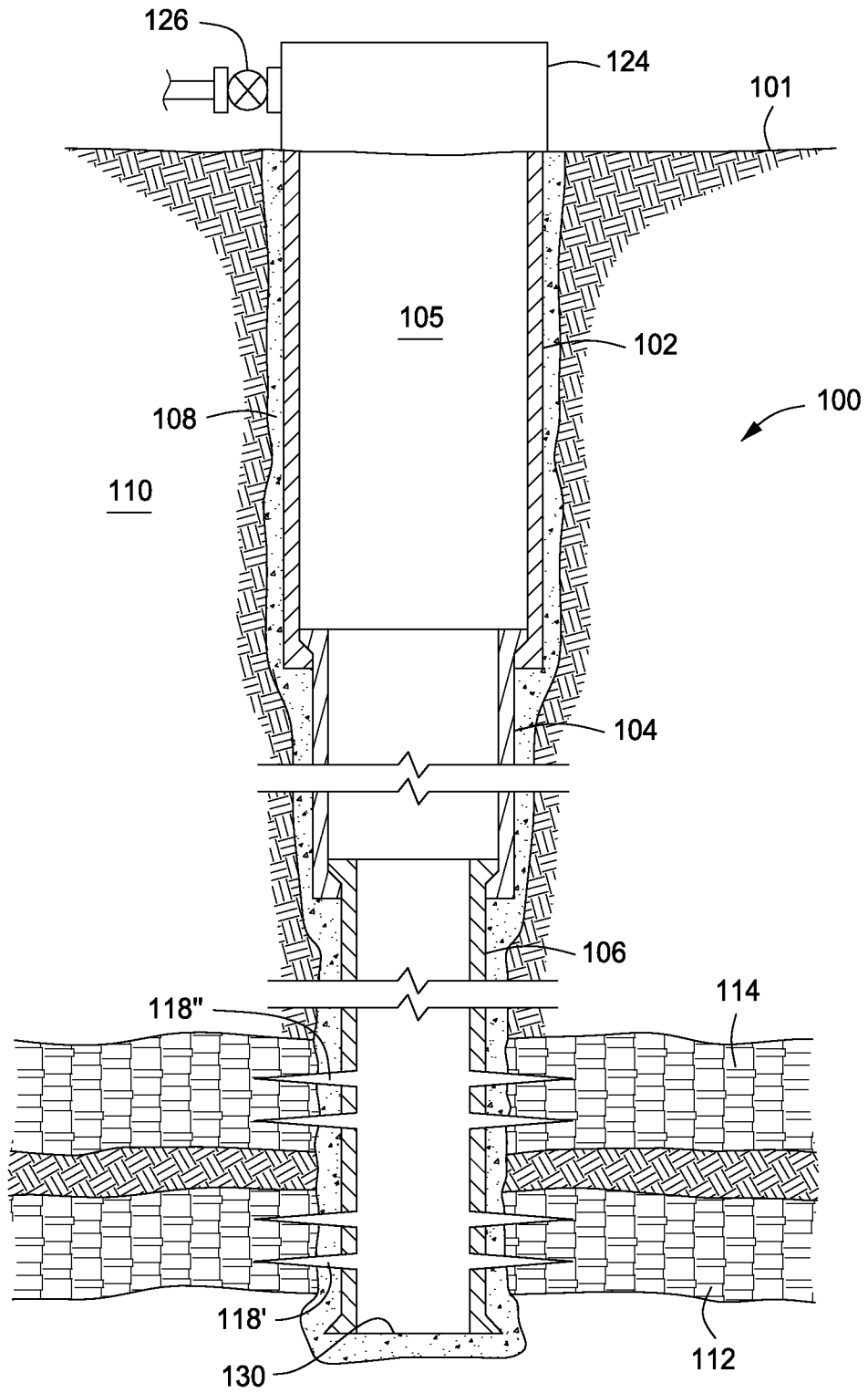

FIG. 1

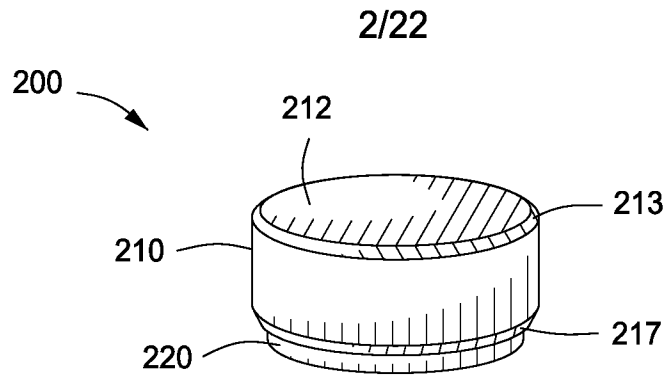

FIG. 2A

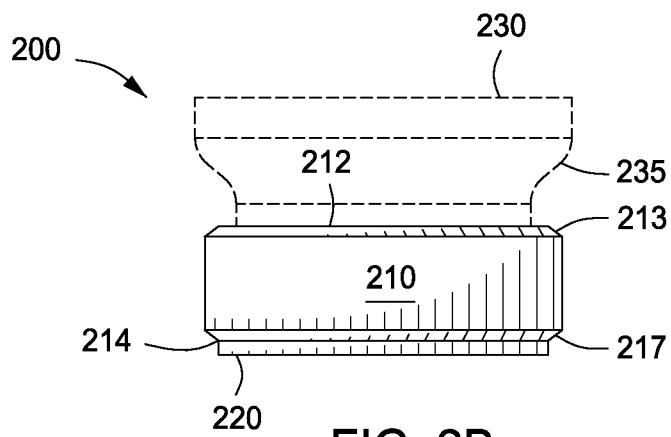

FIG. 2B

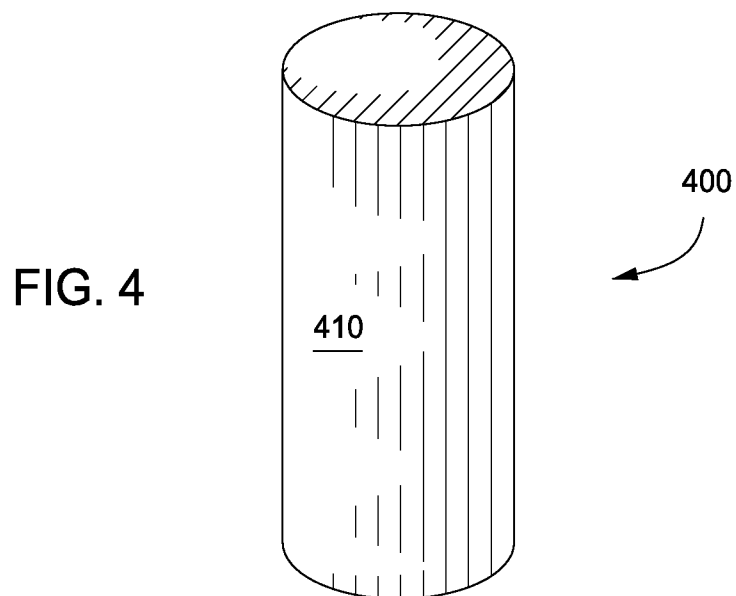

FIG. 4

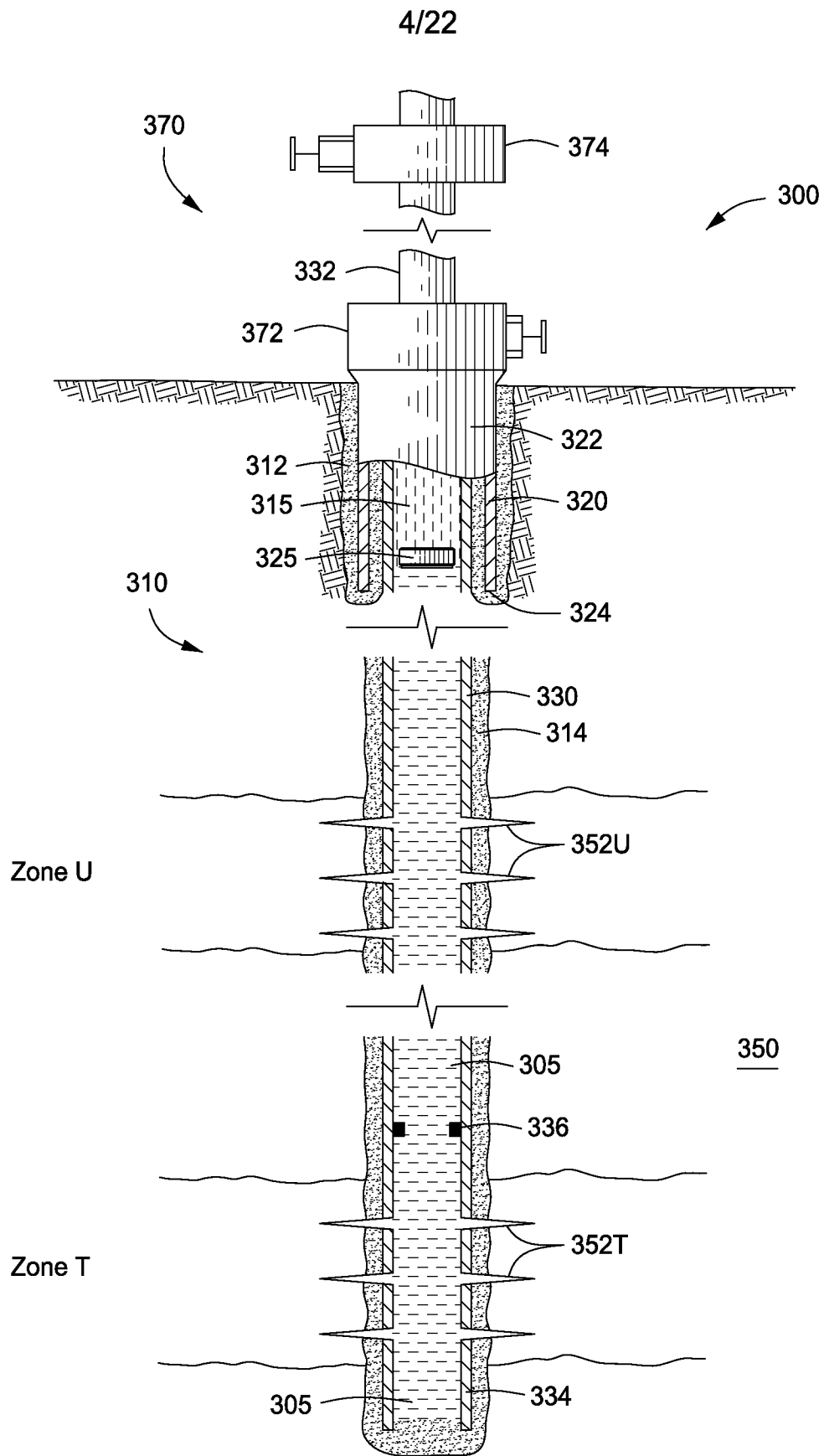

FIG. 3B

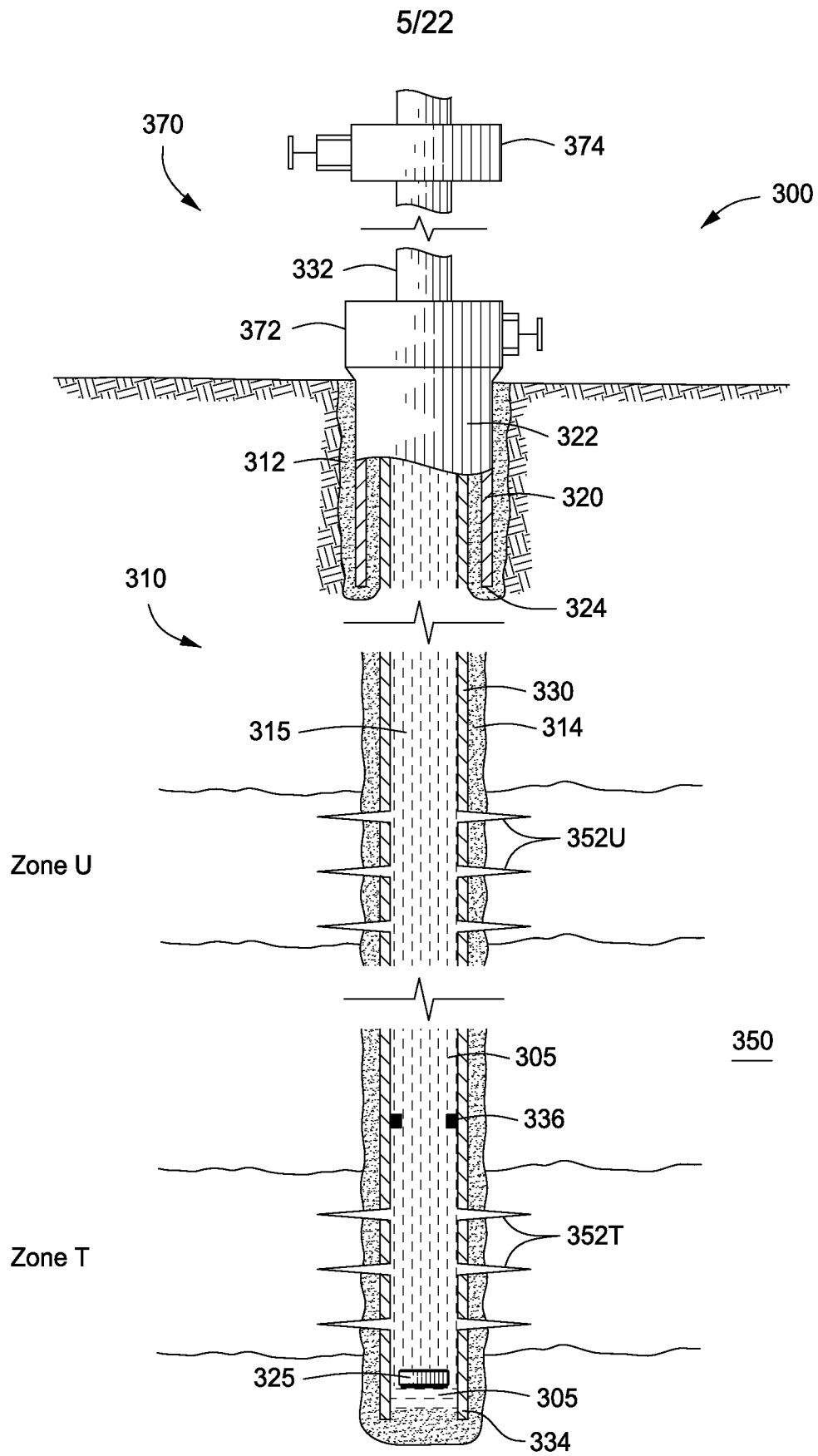

FIG. 3C

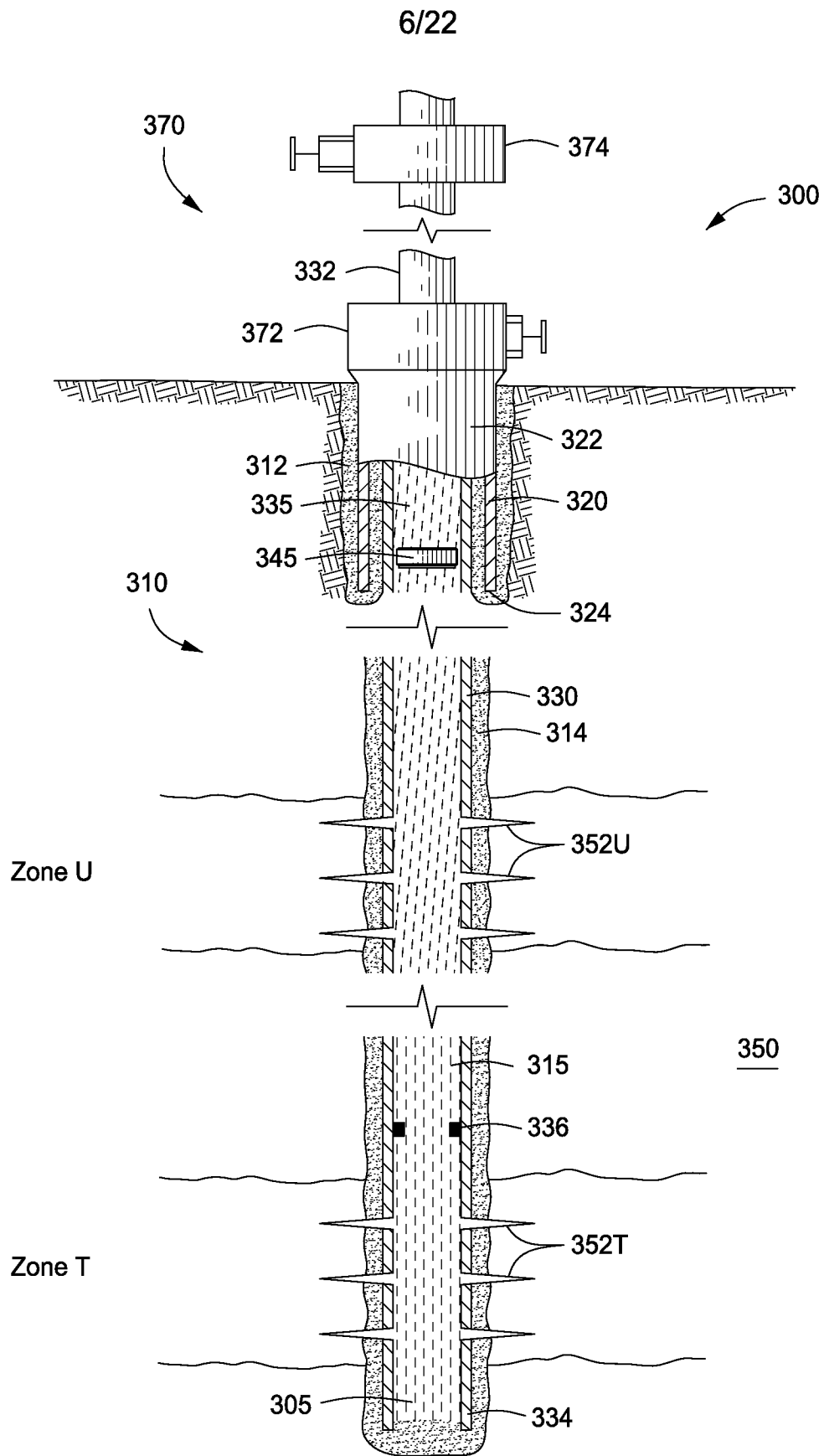

FIG. 3D

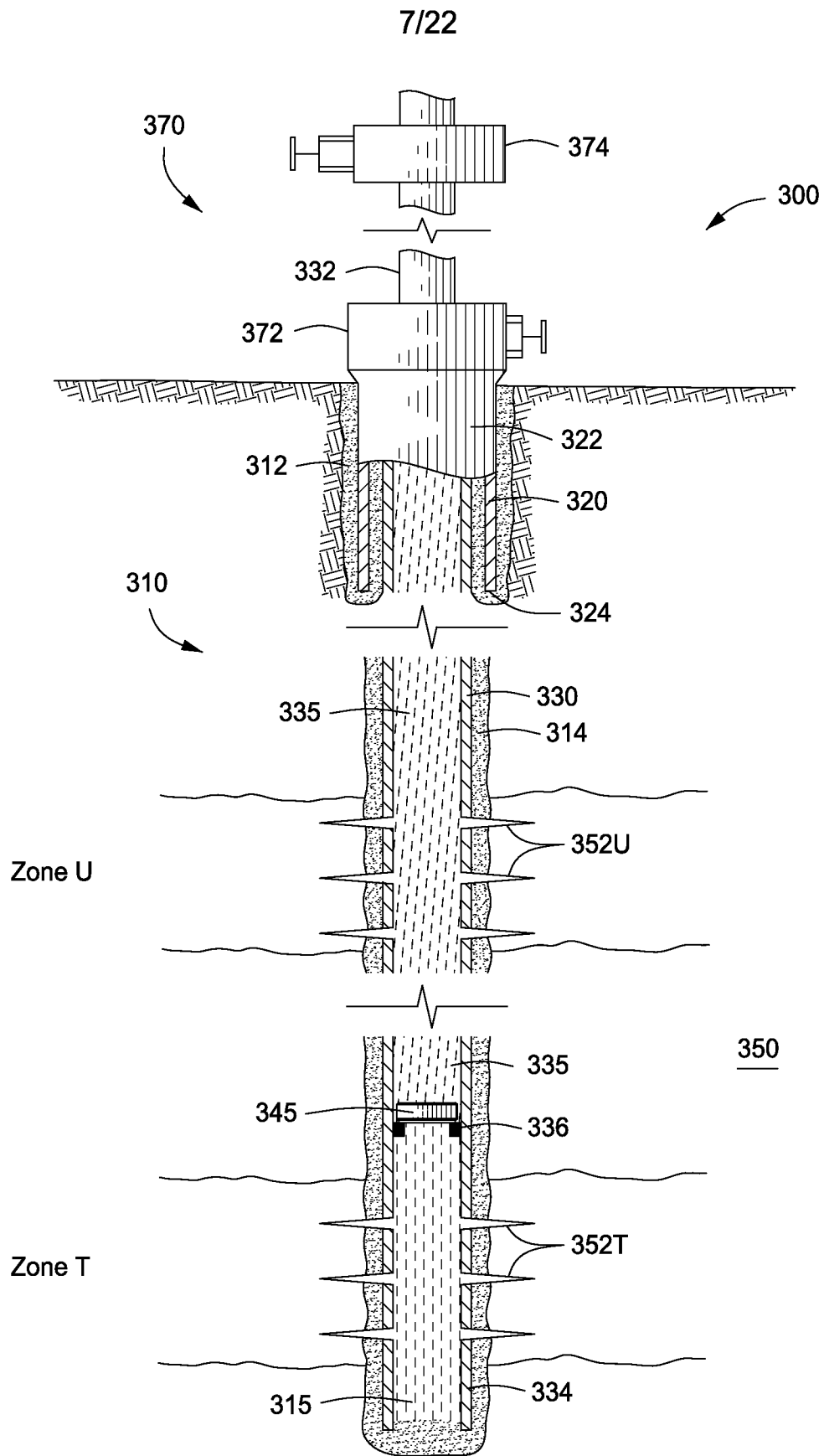

FIG. 3E

8/22

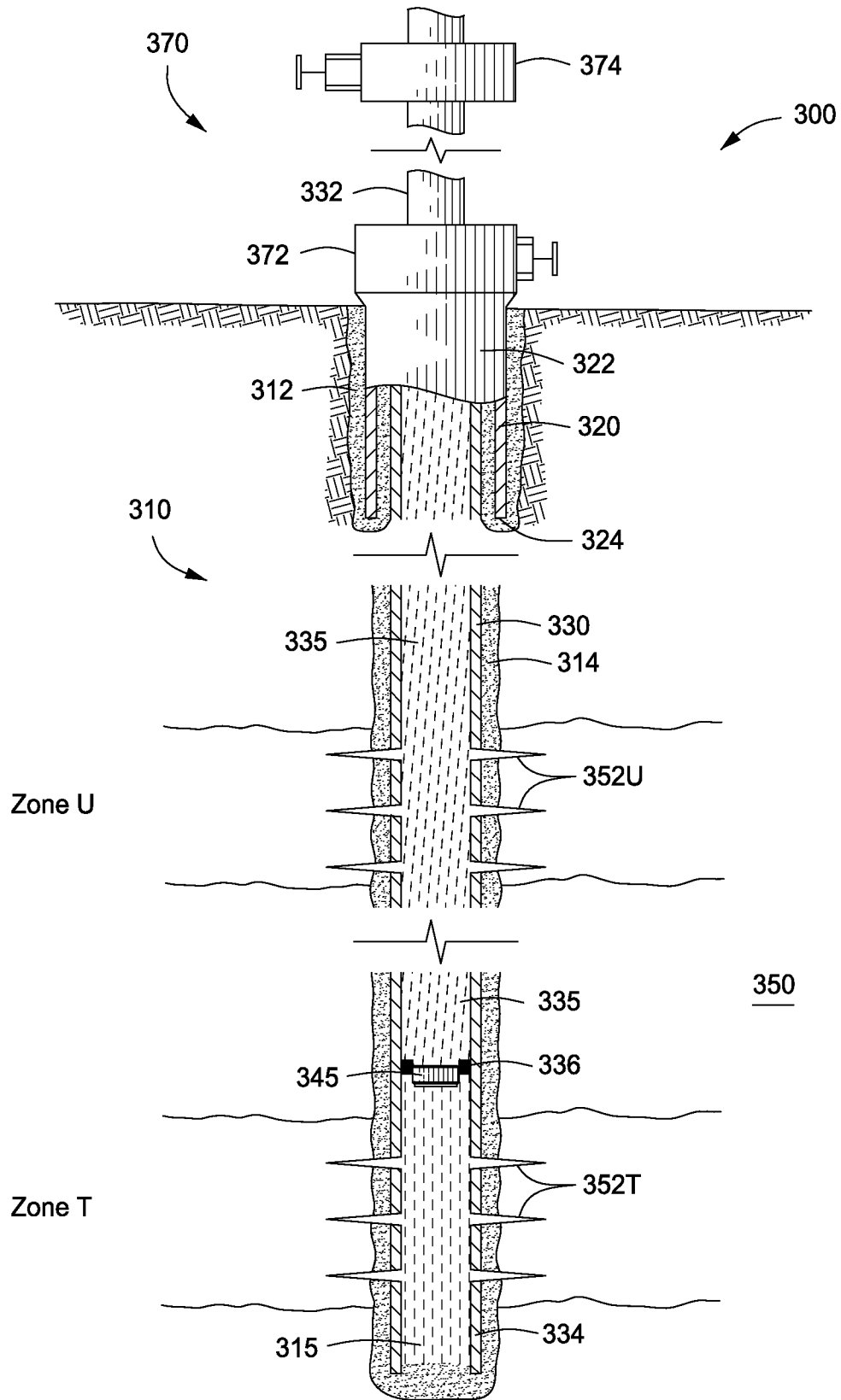

FIG. 3F

10/22

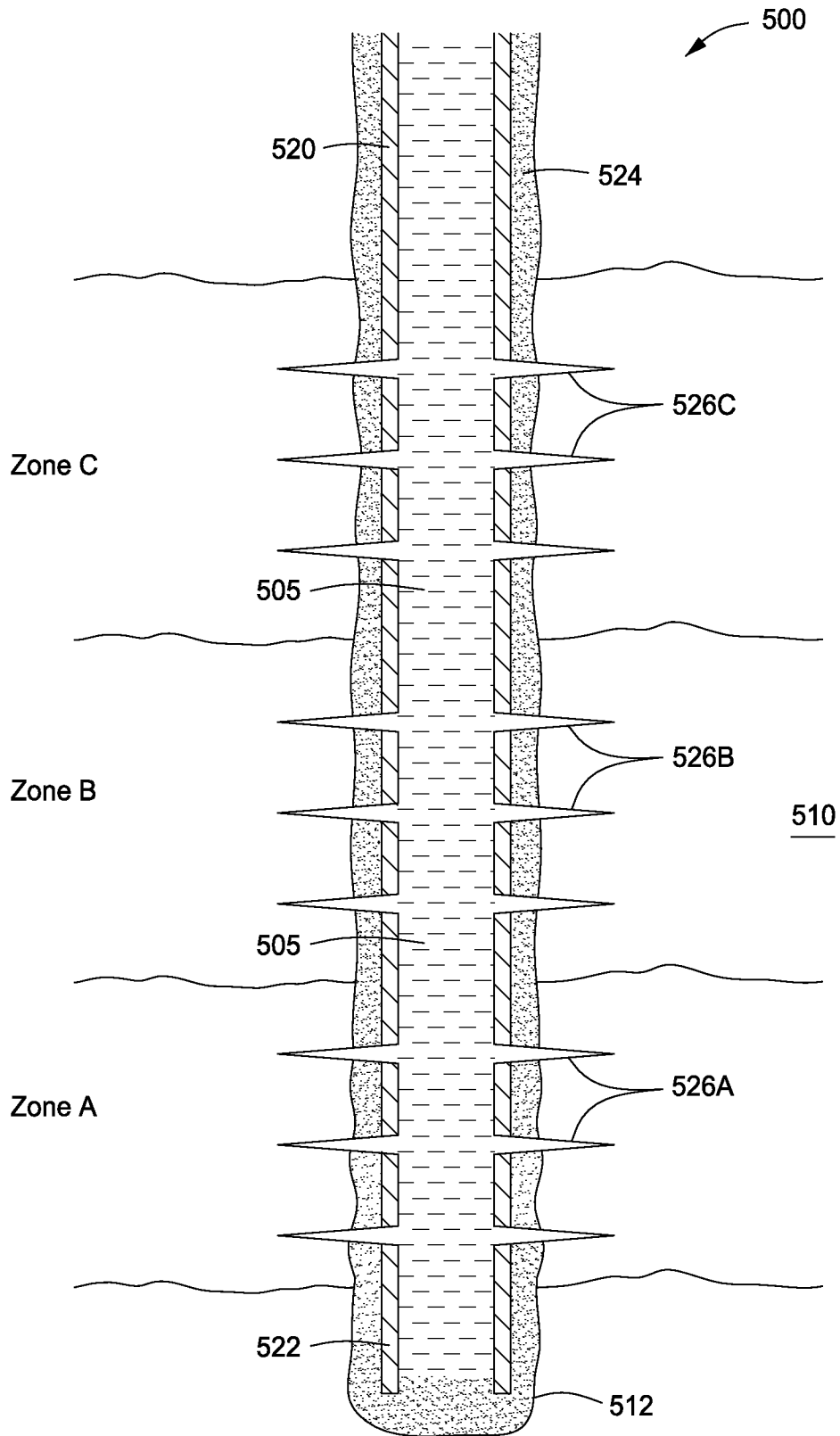

FIG. 5A

11/22

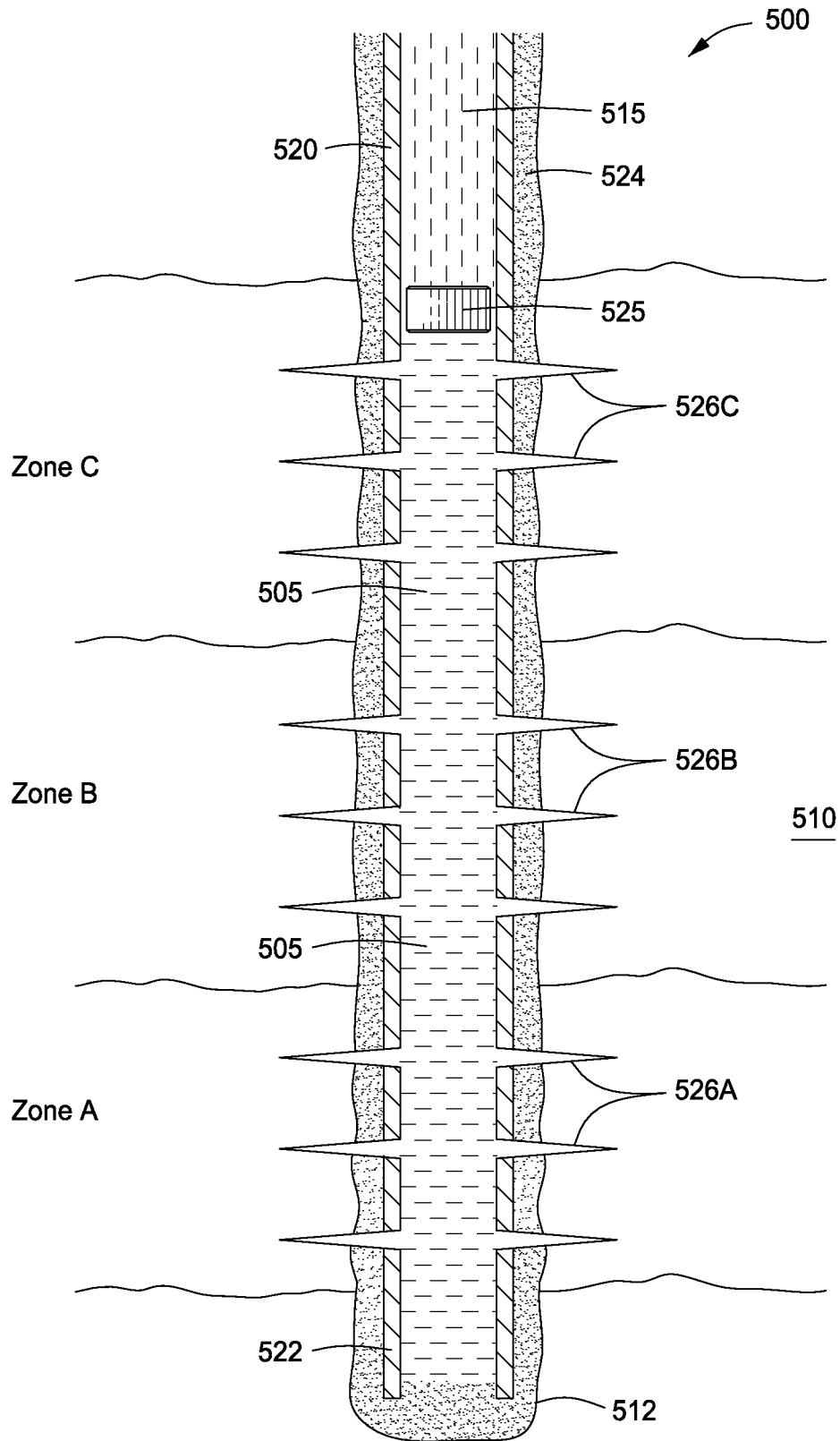

FIG. 5B

12/22

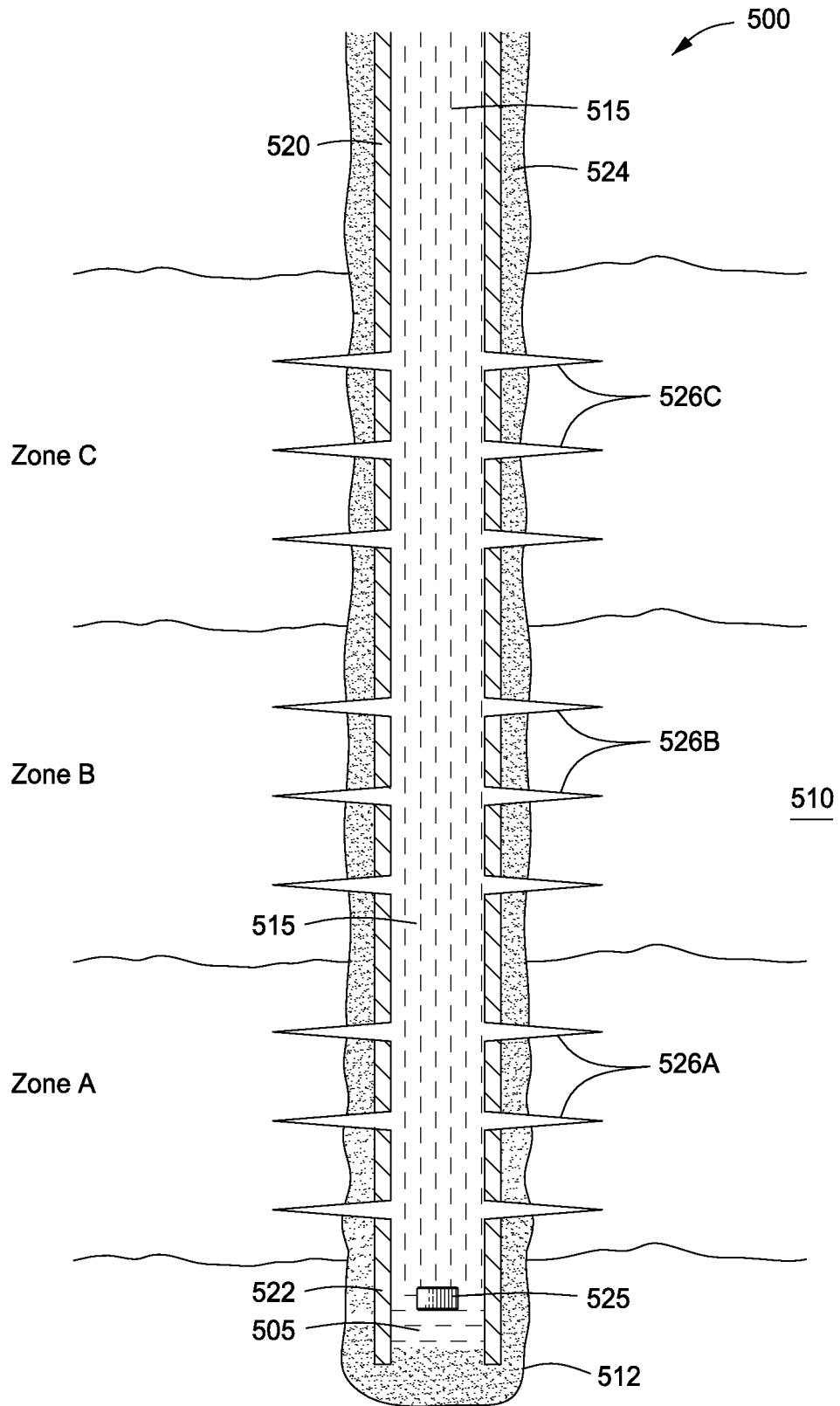

FIG. 5C

13/22

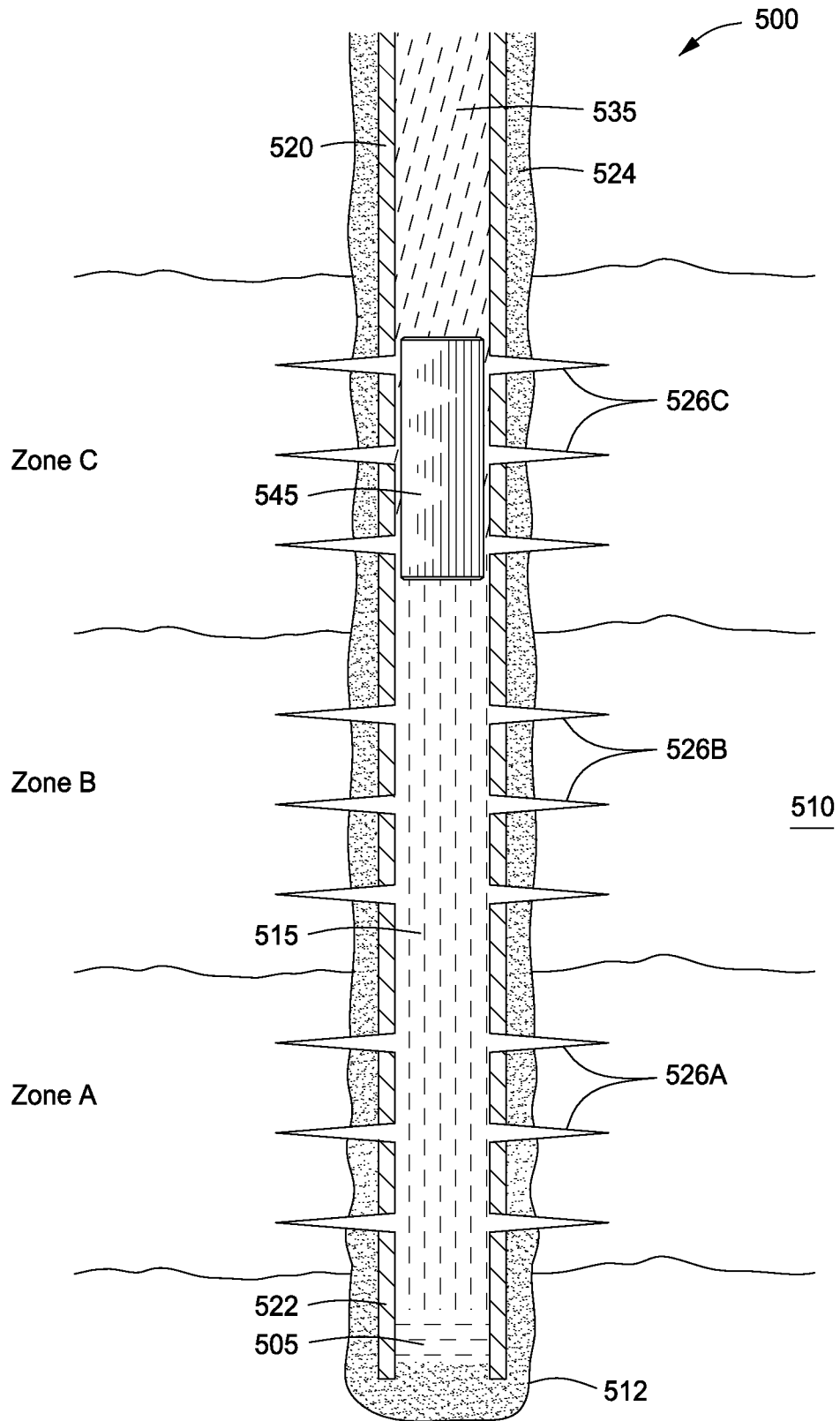

FIG. 5D

14/22

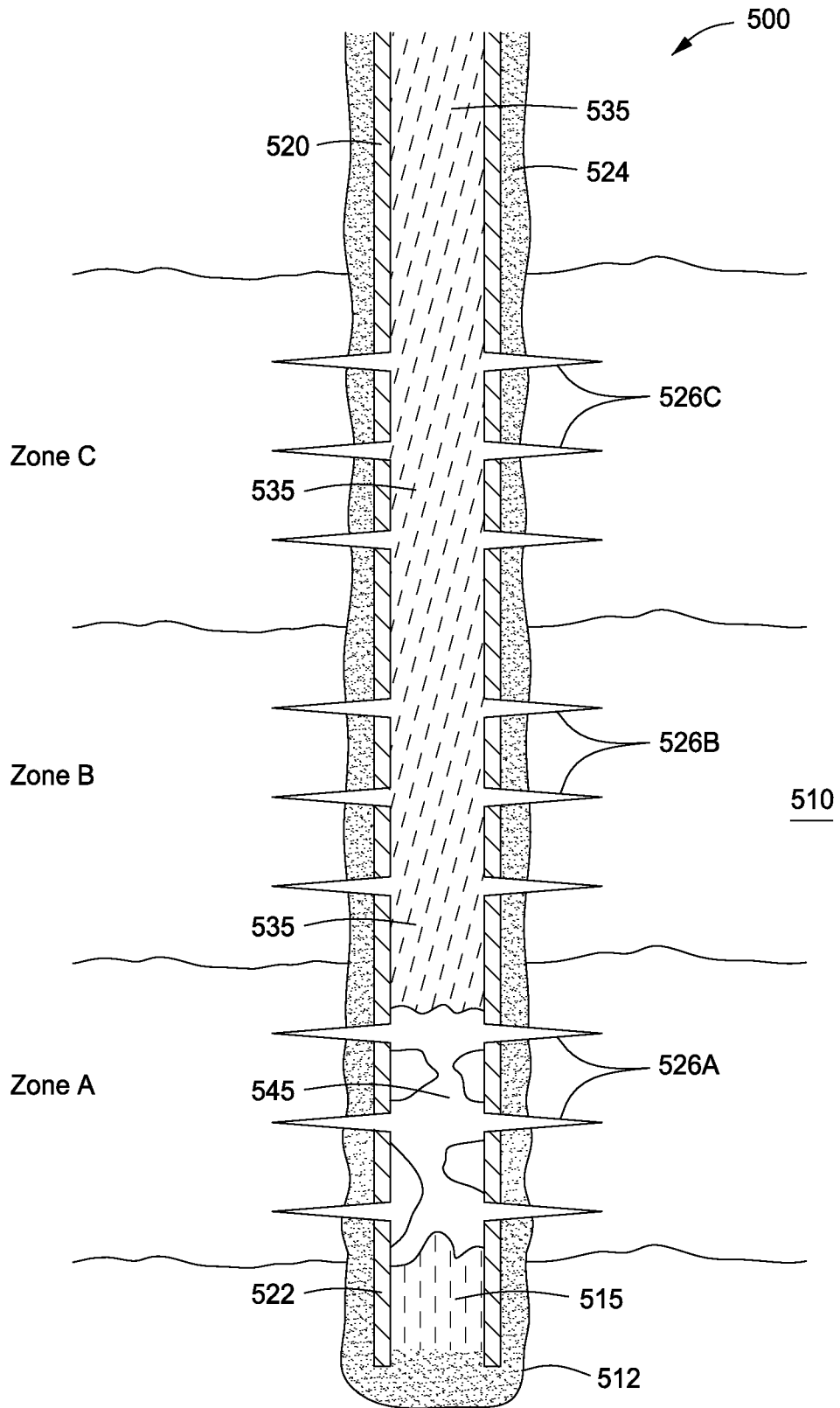

FIG. 5E (1)

16/22

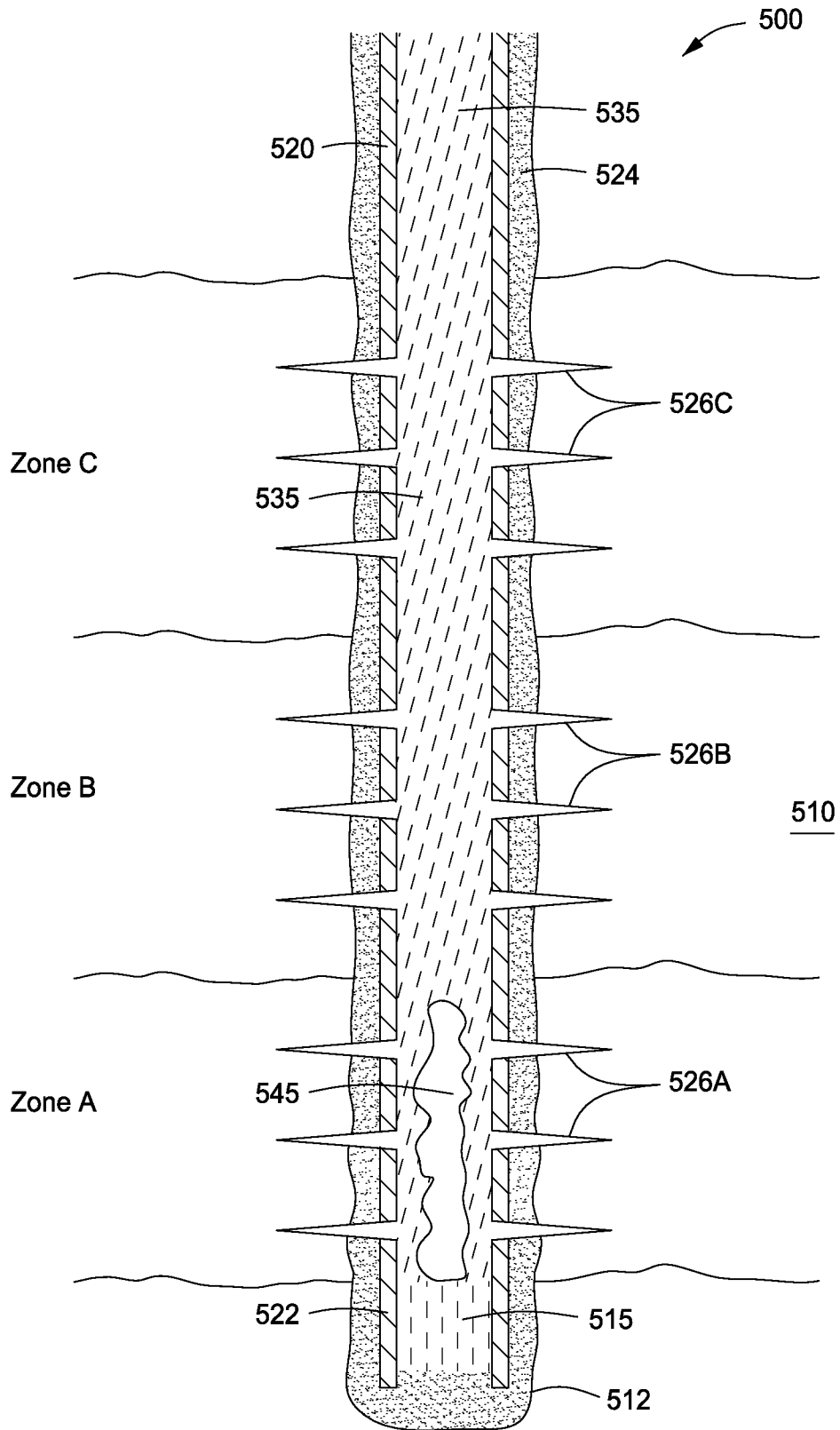

FIG. 5F

18/22

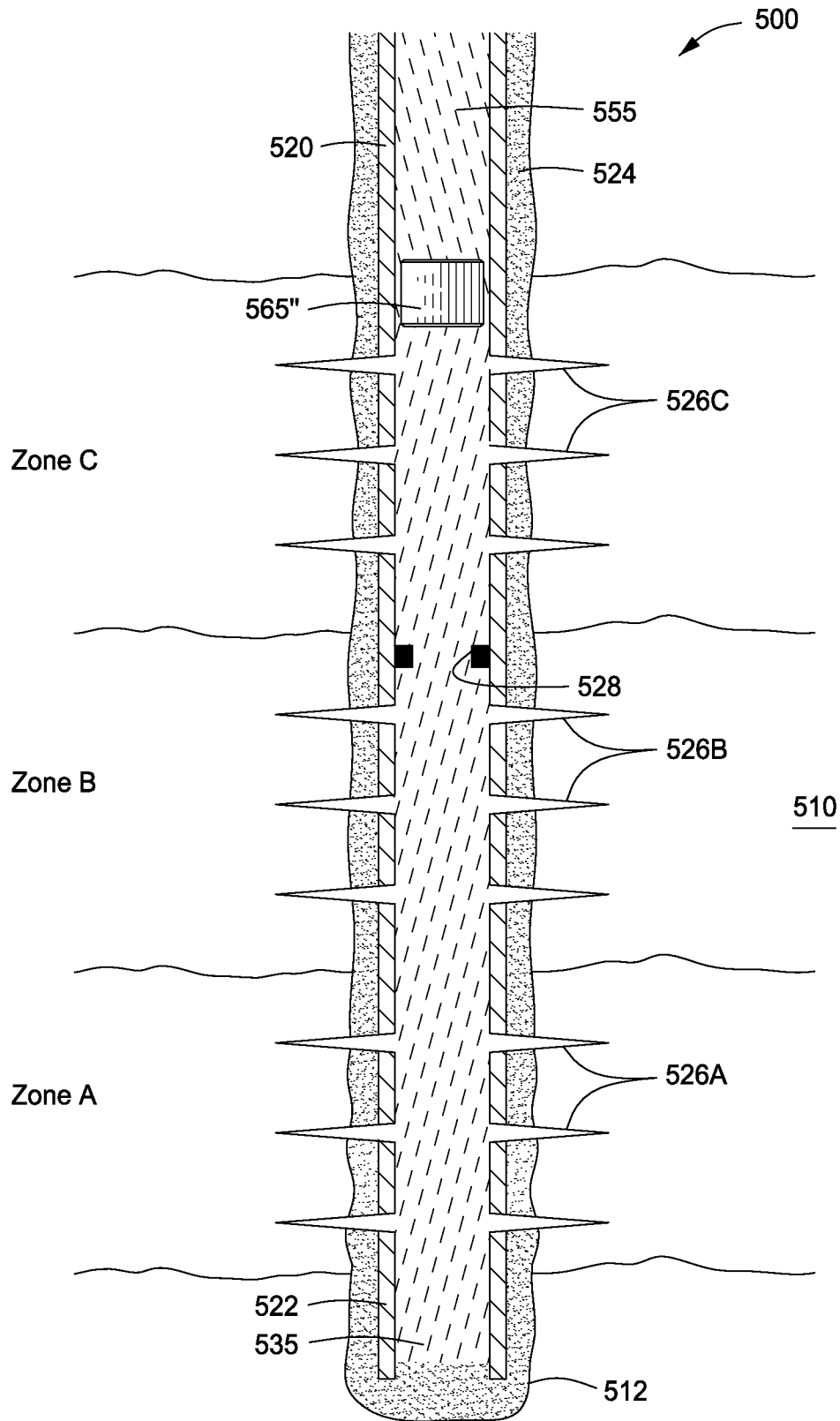

FIG. 5G (2)

22/22

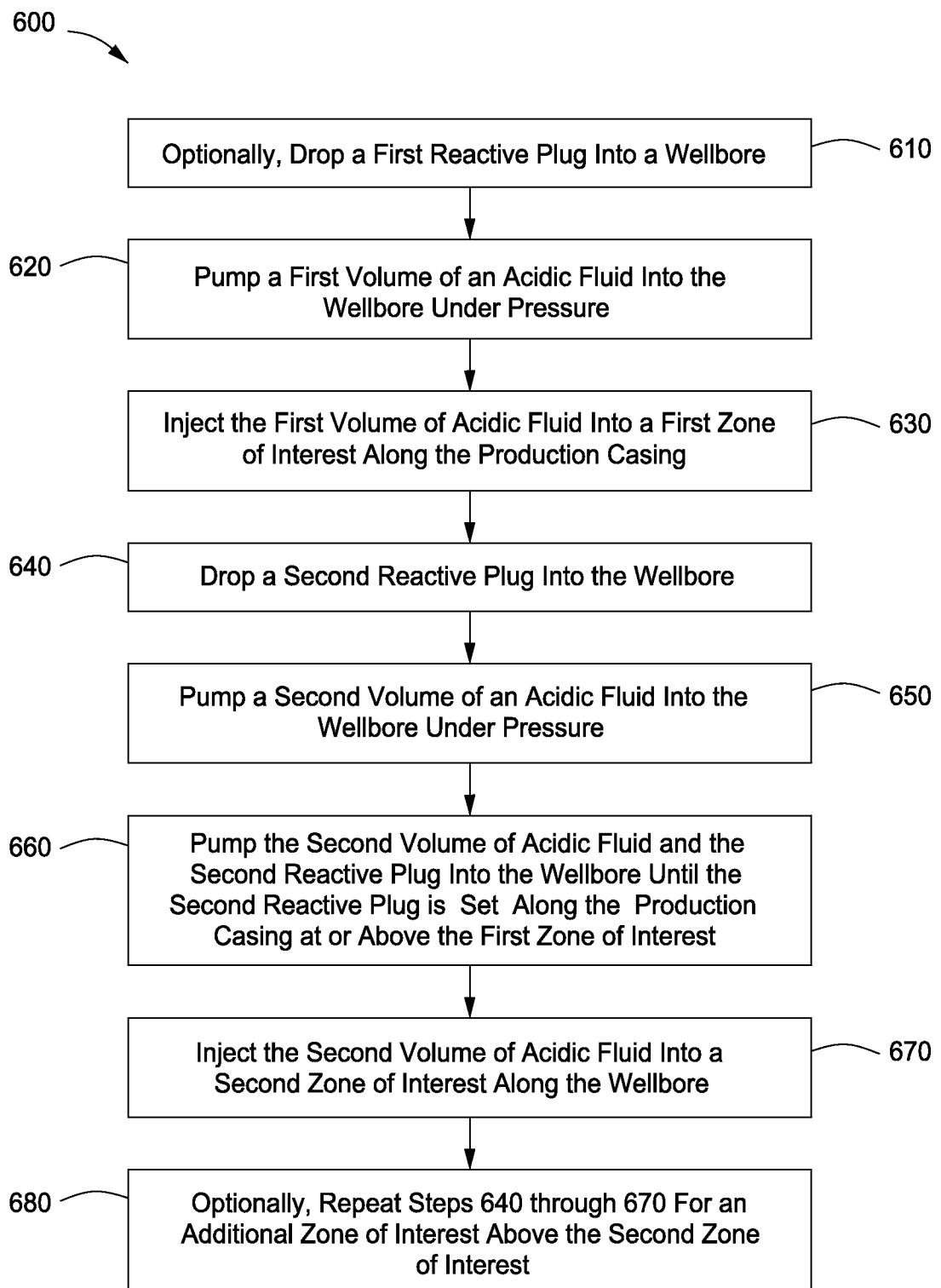

FIG. 6

INTERNATIONAL SEARCH REPORT

International application No.

PCT/US2011/033796

<p>A. CLASSIFICATION OF SUBJECT MATTER IPC(8) - E21B 23/00 (2011.01) USPC - 166/243 According to International Patent Classification (IPC) or to both national classification and IPC</p>																						
<p>B. FIELDS SEARCHED</p> <p>Minimum documentation searched (classification system followed by classification symbols) IPC(8) - E21B 23/00, 43/00 (2011.01) USPC - 166/243, 376</p> <p>Documentation searched other than minimum documentation to the extent that such documents are included in the fields searched</p> <p>Electronic data base consulted during the international search (name of data base and, where practicable, search terms used) PatBase, Google Patents, Google</p>																						
<p>C. DOCUMENTS CONSIDERED TO BE RELEVANT</p> <table border="1"> <thead> <tr> <th>Category*</th> <th>Citation of document, with indication, where appropriate, of the relevant passages</th> <th>Relevant to claim No.</th> </tr> </thead> <tbody> <tr> <td>X</td> <td rowspan="2">US 2005/0205264 A1 (STARR et al) 22 September 2005 (22.09.2005) entire document</td> <td>1-7, 9, 16-18, 21, 23-30</td> </tr> <tr> <td>Y</td> <td>8, 10-15, 19, 20, 22</td> </tr> <tr> <td>Y</td> <td>US 2008/0302538 A1 (HOFMAN) 11 December 2008 (11.12.2008) entire document</td> <td>8</td> </tr> <tr> <td>Y</td> <td>US 2008/0066902 A1 (BULLARD) 20 March 2008 (20.03.2008) entire document</td> <td>10-14</td> </tr> <tr> <td>Y</td> <td>US 5,704,426 A (RYTLEWSKI et al) 06 January 1998 (06.01.1998) entire document</td> <td>14, 15, 19, 20</td> </tr> <tr> <td>Y</td> <td>US 6,581,681 B1 (ZIMMERMAN et al) 24 June 2003 (24.06.2003) entire document</td> <td>20, 22</td> </tr> </tbody> </table>			Category*	Citation of document, with indication, where appropriate, of the relevant passages	Relevant to claim No.	X	US 2005/0205264 A1 (STARR et al) 22 September 2005 (22.09.2005) entire document	1-7, 9, 16-18, 21, 23-30	Y	8, 10-15, 19, 20, 22	Y	US 2008/0302538 A1 (HOFMAN) 11 December 2008 (11.12.2008) entire document	8	Y	US 2008/0066902 A1 (BULLARD) 20 March 2008 (20.03.2008) entire document	10-14	Y	US 5,704,426 A (RYTLEWSKI et al) 06 January 1998 (06.01.1998) entire document	14, 15, 19, 20	Y	US 6,581,681 B1 (ZIMMERMAN et al) 24 June 2003 (24.06.2003) entire document	20, 22
Category*	Citation of document, with indication, where appropriate, of the relevant passages	Relevant to claim No.																				
X	US 2005/0205264 A1 (STARR et al) 22 September 2005 (22.09.2005) entire document	1-7, 9, 16-18, 21, 23-30																				
Y		8, 10-15, 19, 20, 22																				
Y	US 2008/0302538 A1 (HOFMAN) 11 December 2008 (11.12.2008) entire document	8																				
Y	US 2008/0066902 A1 (BULLARD) 20 March 2008 (20.03.2008) entire document	10-14																				
Y	US 5,704,426 A (RYTLEWSKI et al) 06 January 1998 (06.01.1998) entire document	14, 15, 19, 20																				
Y	US 6,581,681 B1 (ZIMMERMAN et al) 24 June 2003 (24.06.2003) entire document	20, 22																				
<p><input type="checkbox"/> Further documents are listed in the continuation of Box C. <input type="checkbox"/></p>																						
<p>* Special categories of cited documents:</p> <table border="0"> <tr> <td>"A" document defining the general state of the art which is not considered to be of particular relevance</td> <td>"T" later document published after the international filing date or priority date and not in conflict with the application but cited to understand the principle or theory underlying the invention</td> </tr> <tr> <td>"E" earlier application or patent but published on or after the international filing date</td> <td>"X" document of particular relevance; the claimed invention cannot be considered novel or cannot be considered to involve an inventive step when the document is taken alone</td> </tr> <tr> <td>"L" document which may throw doubts on priority claim(s) or which is cited to establish the publication date of another citation or other special reason (as specified)</td> <td>"Y" document of particular relevance; the claimed invention cannot be considered to involve an inventive step when the document is combined with one or more other such documents, such combination being obvious to a person skilled in the art</td> </tr> <tr> <td>"O" document referring to an oral disclosure, use, exhibition or other means</td> <td>"&" document member of the same patent family</td> </tr> <tr> <td>"P" document published prior to the international filing date but later than the priority date claimed</td> <td></td> </tr> </table>			"A" document defining the general state of the art which is not considered to be of particular relevance	"T" later document published after the international filing date or priority date and not in conflict with the application but cited to understand the principle or theory underlying the invention	"E" earlier application or patent but published on or after the international filing date	"X" document of particular relevance; the claimed invention cannot be considered novel or cannot be considered to involve an inventive step when the document is taken alone	"L" document which may throw doubts on priority claim(s) or which is cited to establish the publication date of another citation or other special reason (as specified)	"Y" document of particular relevance; the claimed invention cannot be considered to involve an inventive step when the document is combined with one or more other such documents, such combination being obvious to a person skilled in the art	"O" document referring to an oral disclosure, use, exhibition or other means	"&" document member of the same patent family	"P" document published prior to the international filing date but later than the priority date claimed											
"A" document defining the general state of the art which is not considered to be of particular relevance	"T" later document published after the international filing date or priority date and not in conflict with the application but cited to understand the principle or theory underlying the invention																					
"E" earlier application or patent but published on or after the international filing date	"X" document of particular relevance; the claimed invention cannot be considered novel or cannot be considered to involve an inventive step when the document is taken alone																					
"L" document which may throw doubts on priority claim(s) or which is cited to establish the publication date of another citation or other special reason (as specified)	"Y" document of particular relevance; the claimed invention cannot be considered to involve an inventive step when the document is combined with one or more other such documents, such combination being obvious to a person skilled in the art																					
"O" document referring to an oral disclosure, use, exhibition or other means	"&" document member of the same patent family																					
"P" document published prior to the international filing date but later than the priority date claimed																						
<p>Date of the actual completion of the international search</p> <p>07 July 2011</p>		<p>Date of mailing of the international search report</p> <p>12 JUL 2011</p>																				
<p>Name and mailing address of the ISA/US</p> <p>Mail Stop PCT, Attn: ISA/US, Commissioner for Patents P.O. Box 1450, Alexandria, Virginia 22313-1450 Facsimile No. 571-273-3201</p>		<p>Authorized officer:</p> <p>Blaine R. Copenheaver</p> <p>PCT Helpdesk: 571-272-4300 PCT OSP: 571-272-7774</p>																				